



US 20040130250A1

(19) **United States**

(12) **Patent Application Publication**
Cleveland et al.

(10) **Pub. No.: US 2004/0130250 A1**

(43) **Pub. Date: Jul. 8, 2004**

(54) **GUN SAFE WITH CONFIGURABLE INTERIOR**

Related U.S. Application Data

(76) Inventors: **Terri P. Cleveland**, Holley, NY (US); **Patrick J. Beattie**, Rush, NY (US); **R. David Pallo**, Fairport, NY (US); **Torsten Rhode**, Canandaigua, NY (US); **Kelvin H. Wildman**, Honeoye Falls, NY (US); **Peter F. Lynch**, Skaneateles, NY (US); **Scott W. Osiecki**, Skaneateles, NY (US); **Ronald J. Kingston**, Syracuse, NY (US); **Chad P. Paris**, Coram, NY (US); **Daniel A. Matijas**, Weedsport, NY (US)

(60) Provisional application No. 60/427,200, filed on Nov. 18, 2002.

Publication Classification

(51) **Int. Cl.⁷ A47B 95/00**

(52) **U.S. Cl. 312/409; 312/351**

(57) **ABSTRACT**

A configurable safe module for storing firearms is provided. The configurable safe module includes a bracket and at least one barrel receiving module. The bracket is adapted to be positioned on an interior surface of the safe. The barrel receiving module has at least one barrel receiving cradle for receiving a barrel of a gun and a clip for movably mounting the barrel receiving module to the bracket. The configurable safe module may also include an extension member to further separate a gun placed in the receiving module from an interior wall of a storage compartment.

Correspondence Address:
JAECKLE FLEISCHMANN & MUGEL, LLP
Suite 200
39 State Street
Rochester, NY 14614-1310 (US)

(21) Appl. No.: **10/715,241**

(22) Filed: **Nov. 17, 2003**

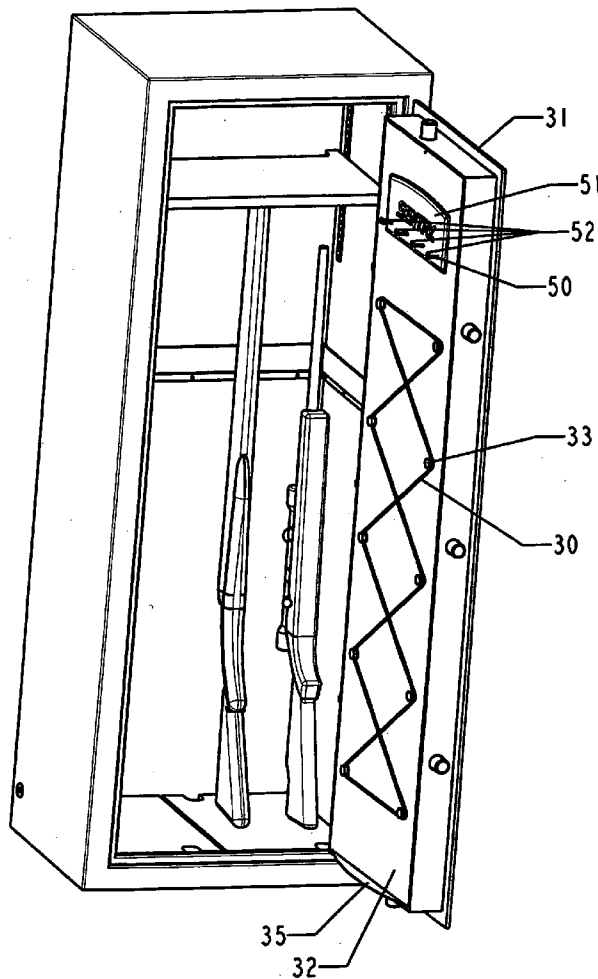

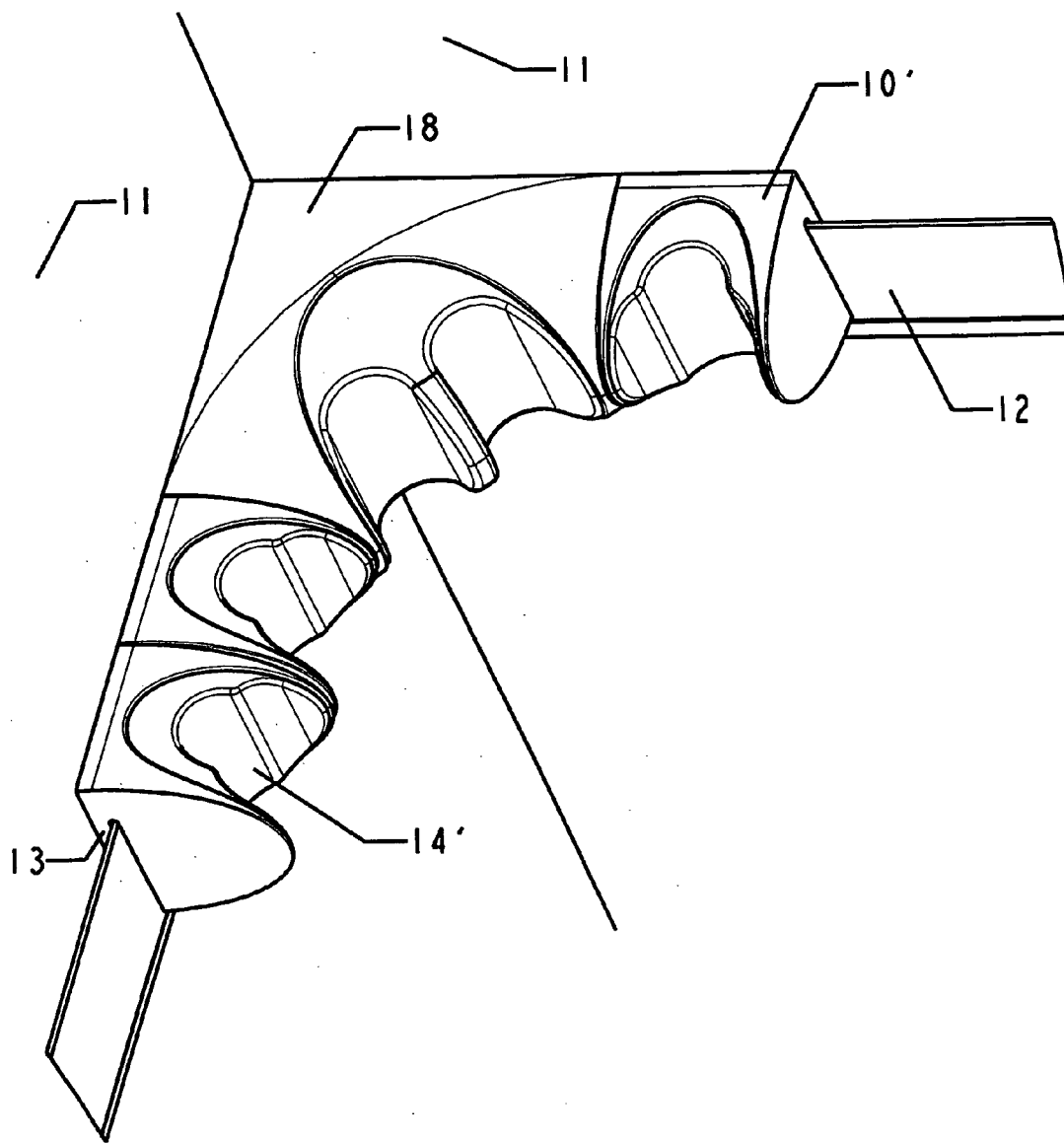

FIG. 1A

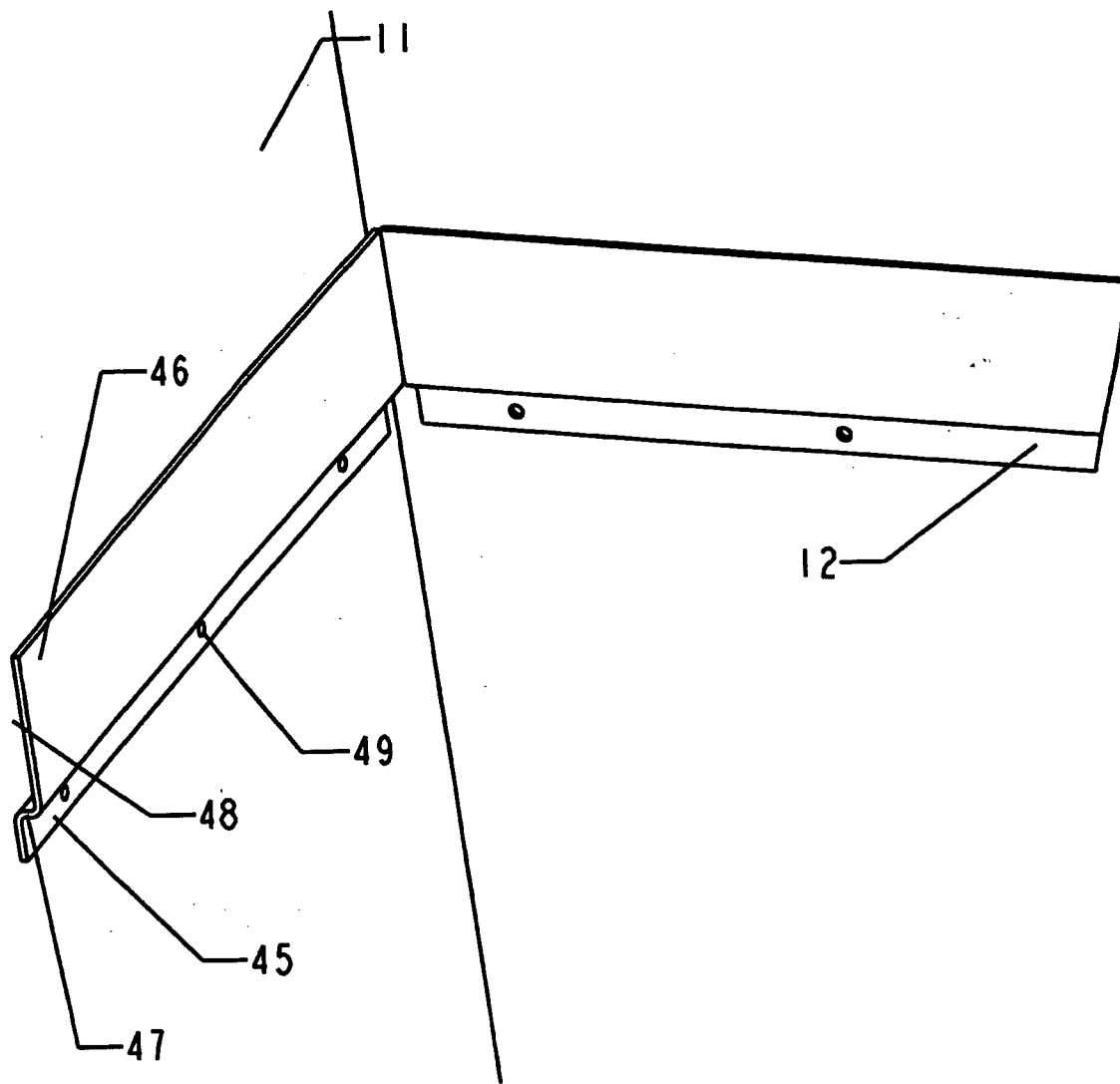

FIG. 1B

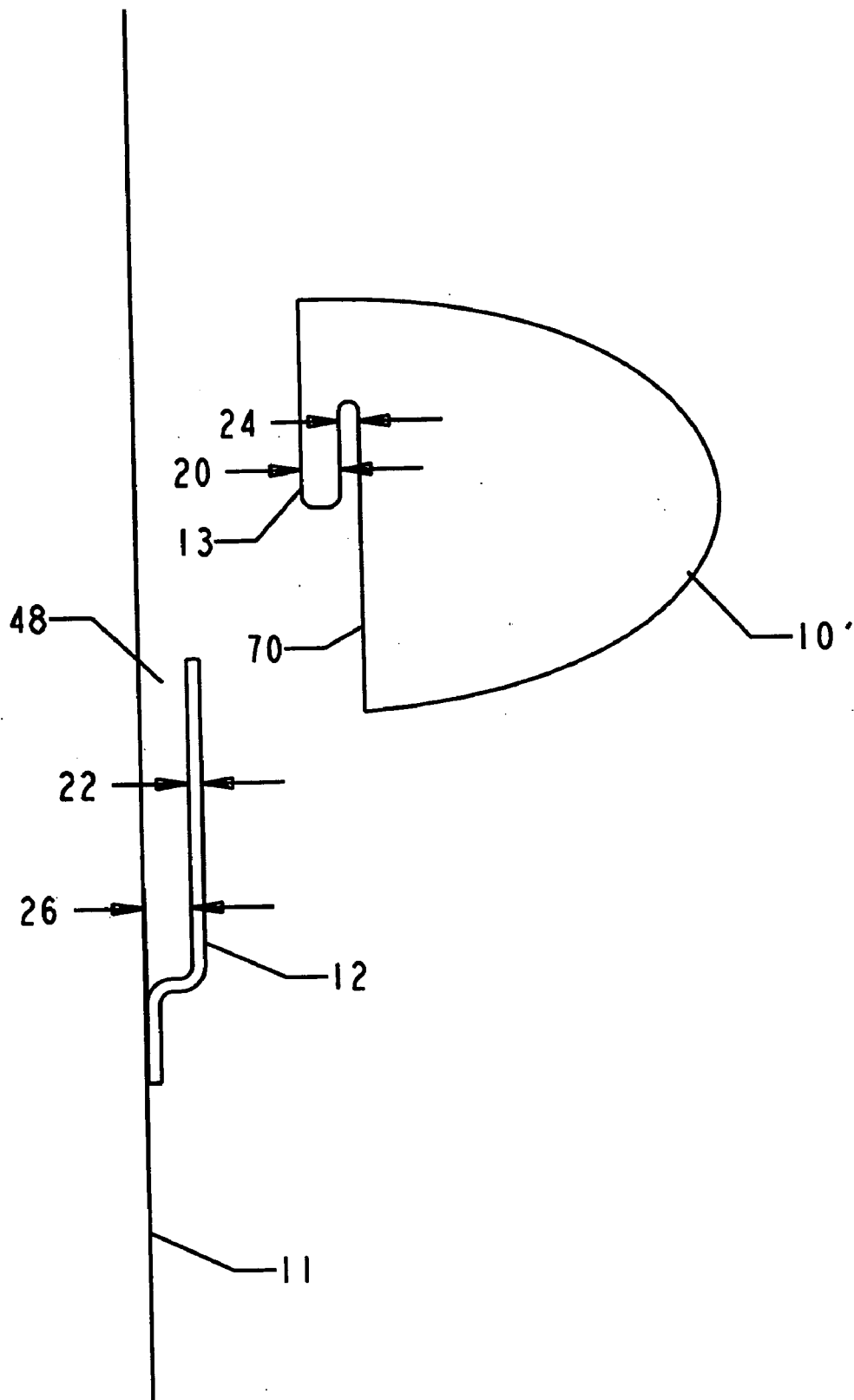

FIG. 1C

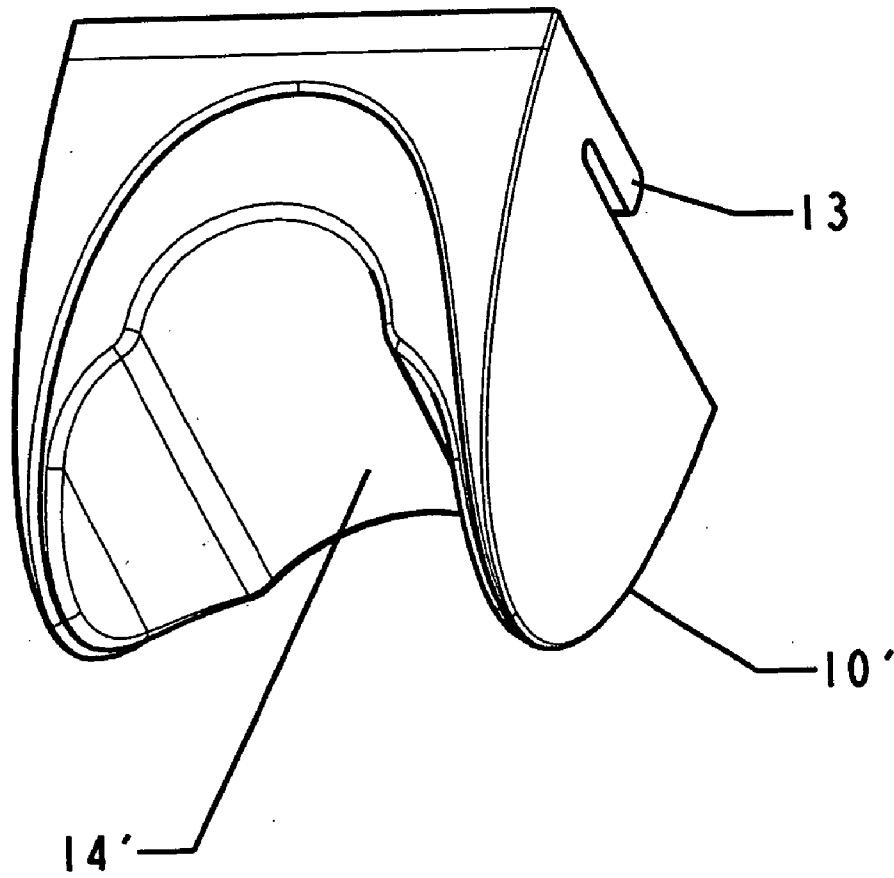

FIG. 2A

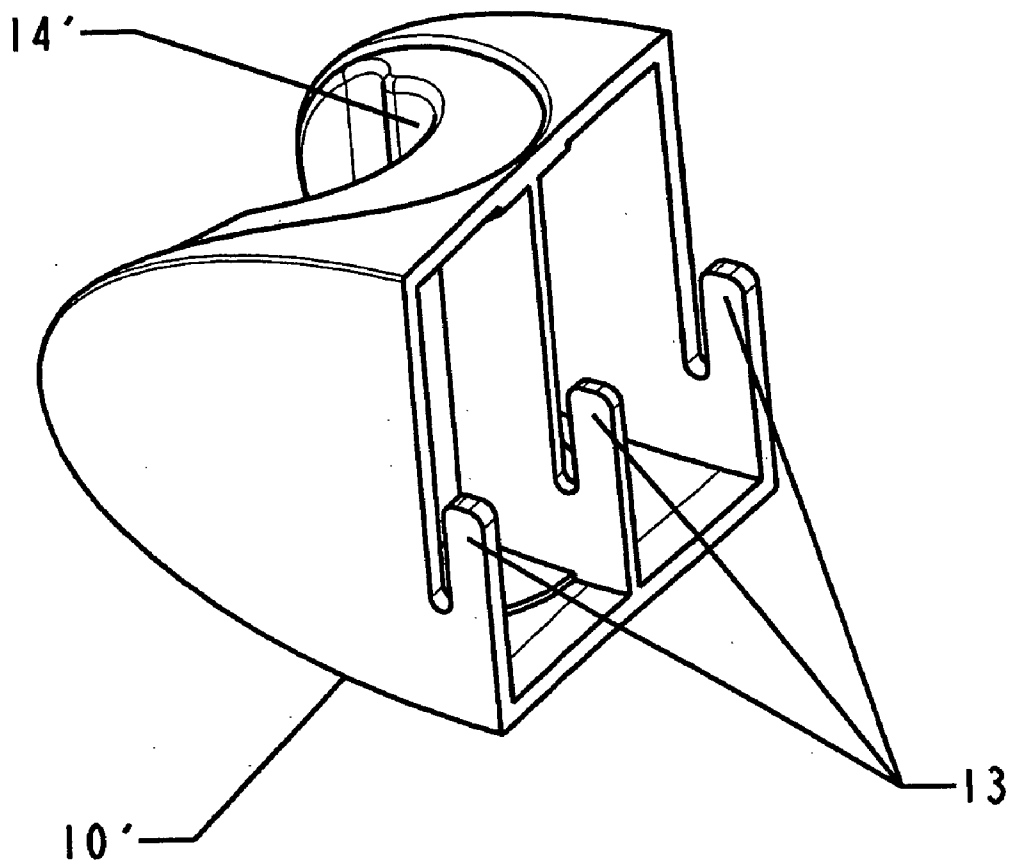

FIG. 2B

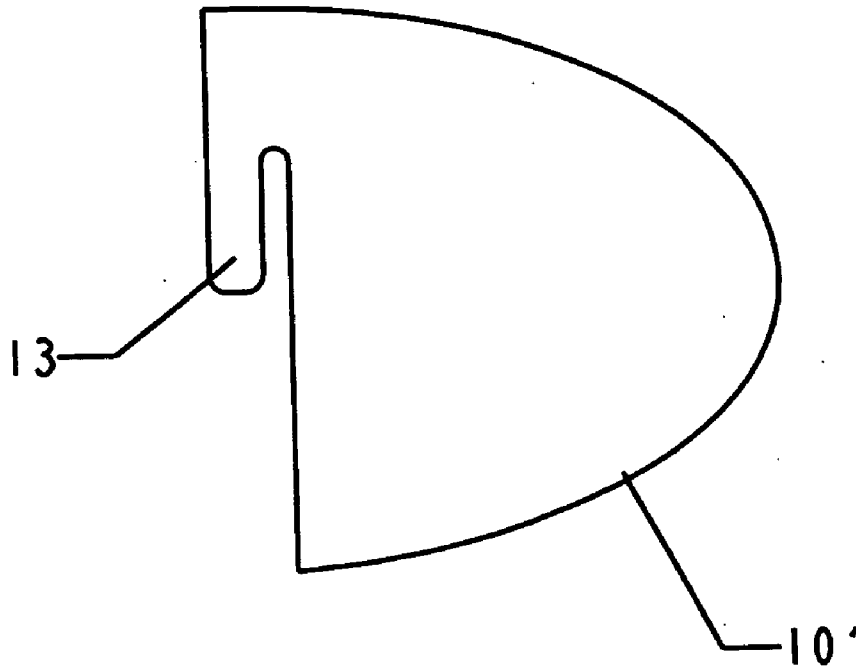

FIG. 2C

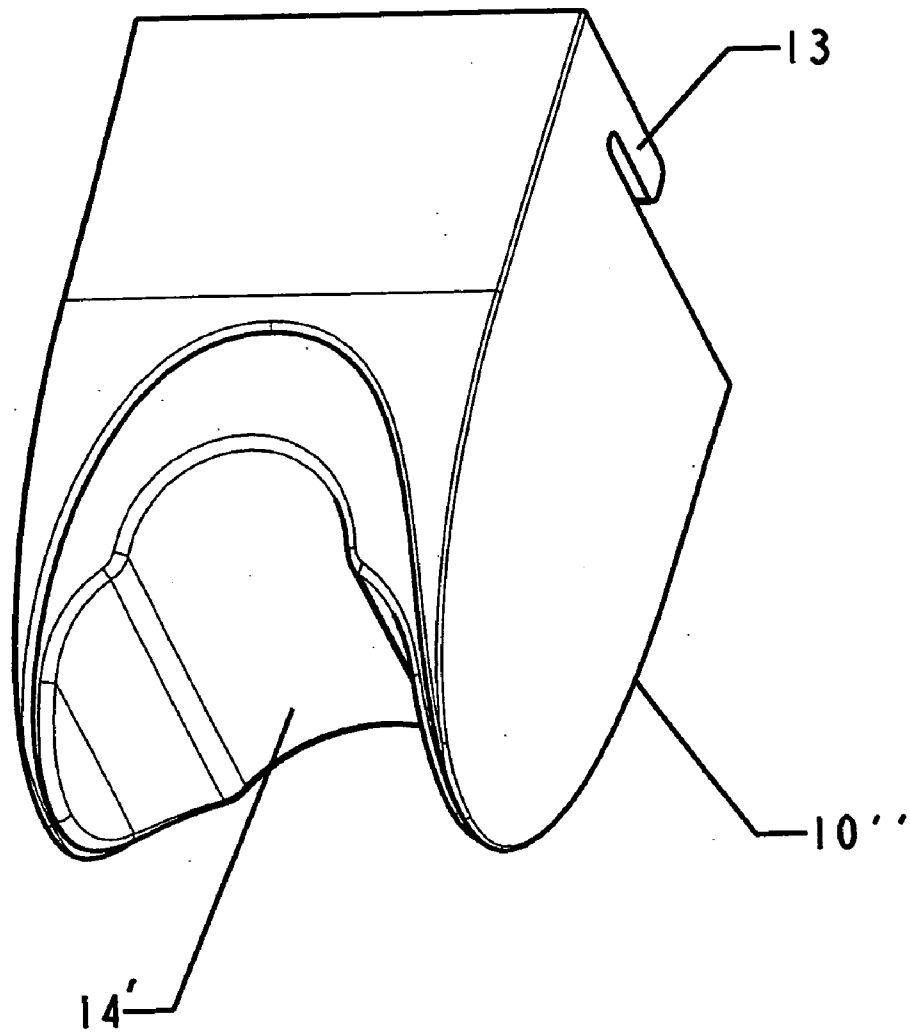

FIG. 2D

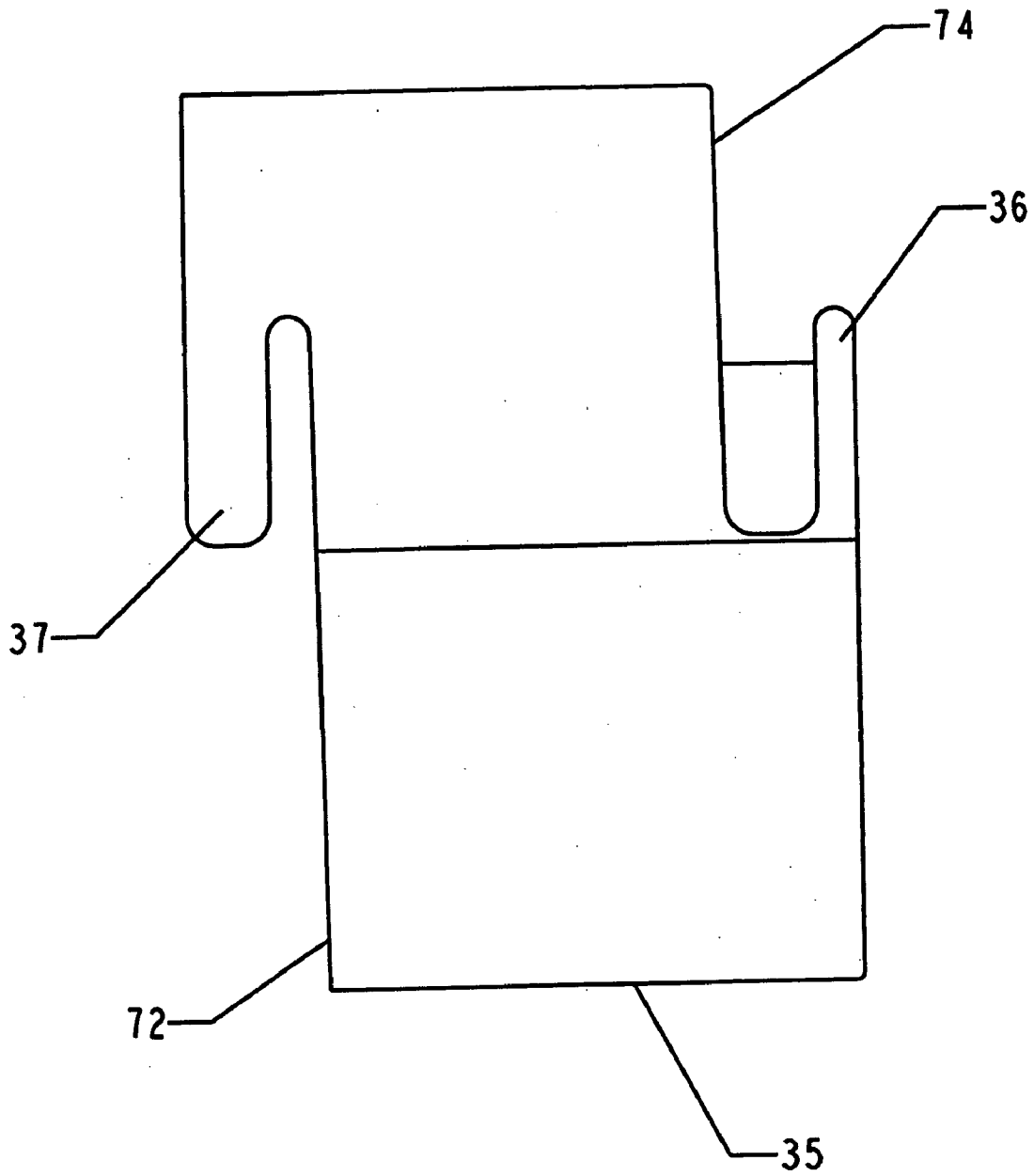

FIG. 2E

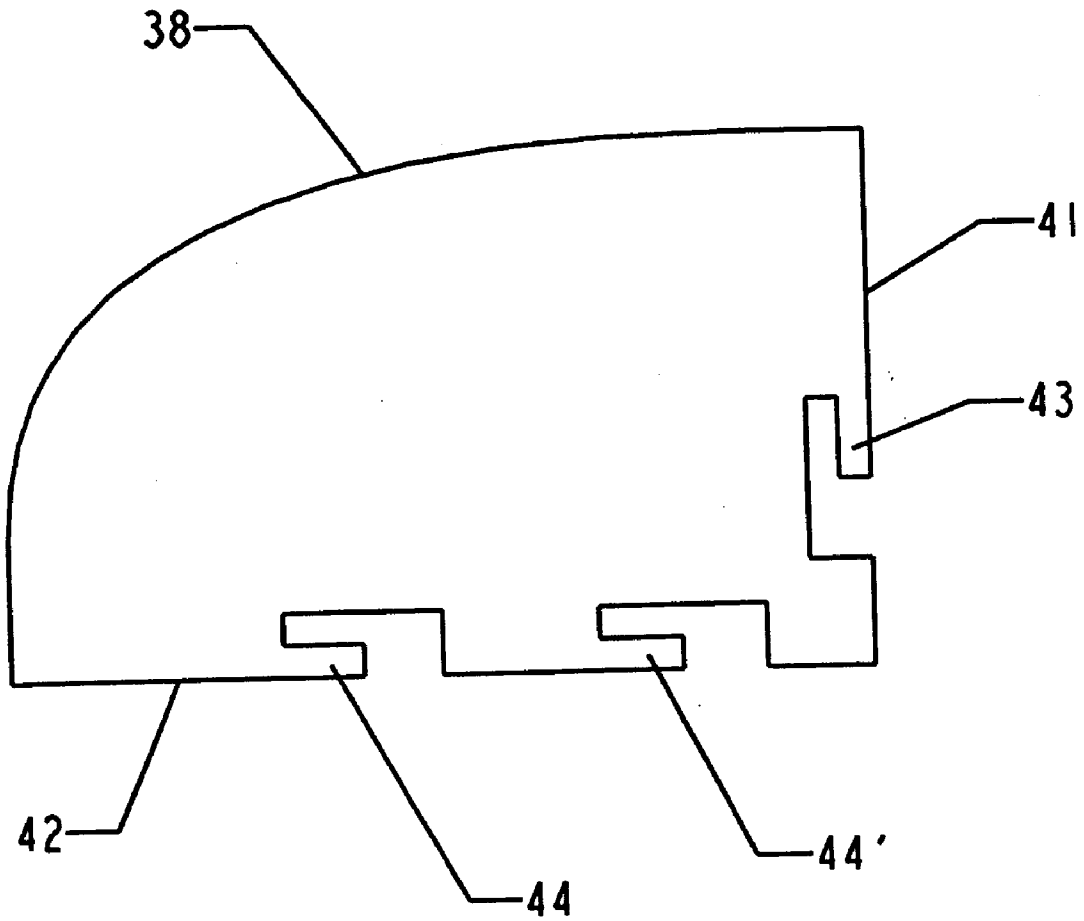

FIG. 2F

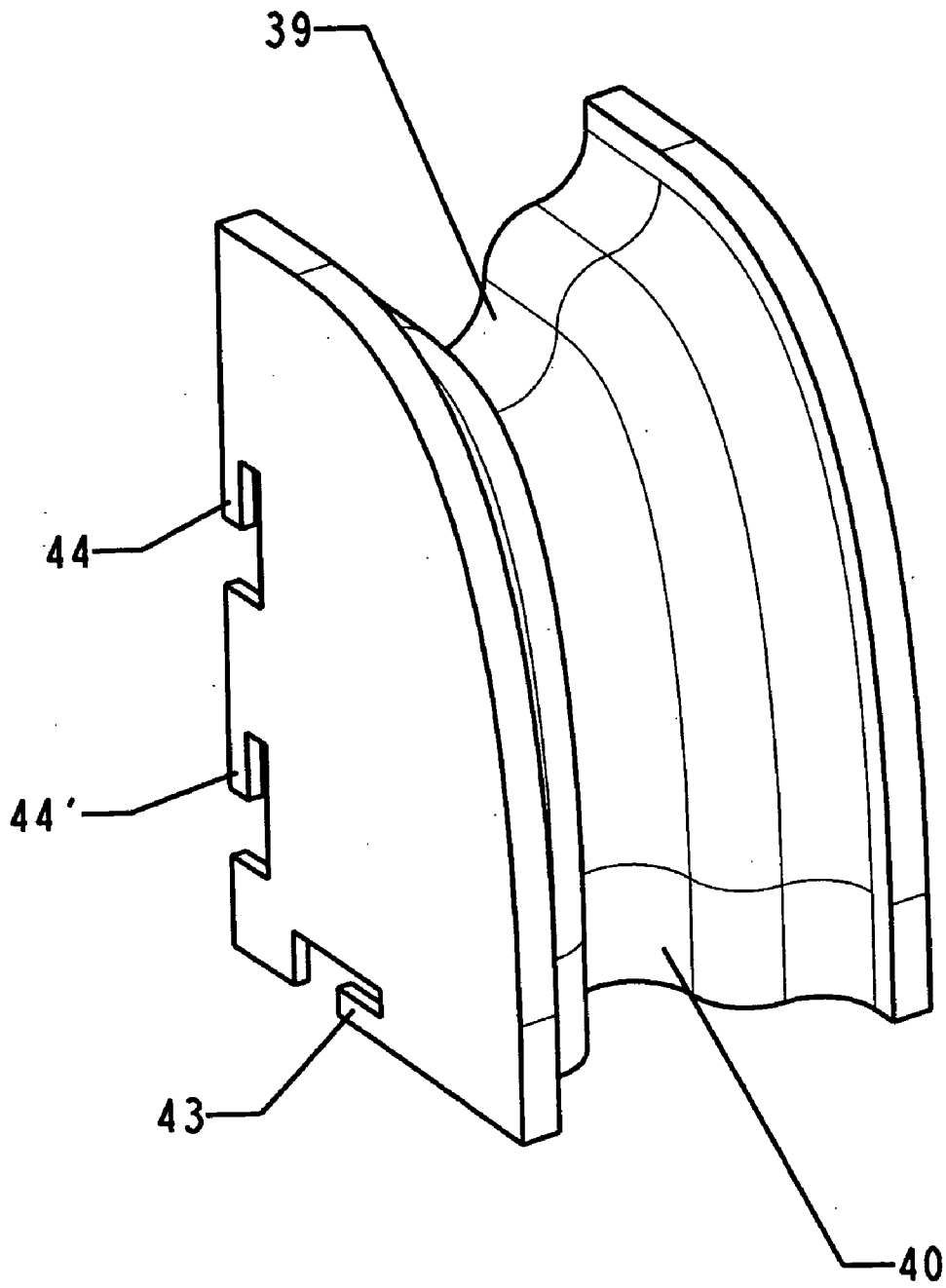

FIG. 2G

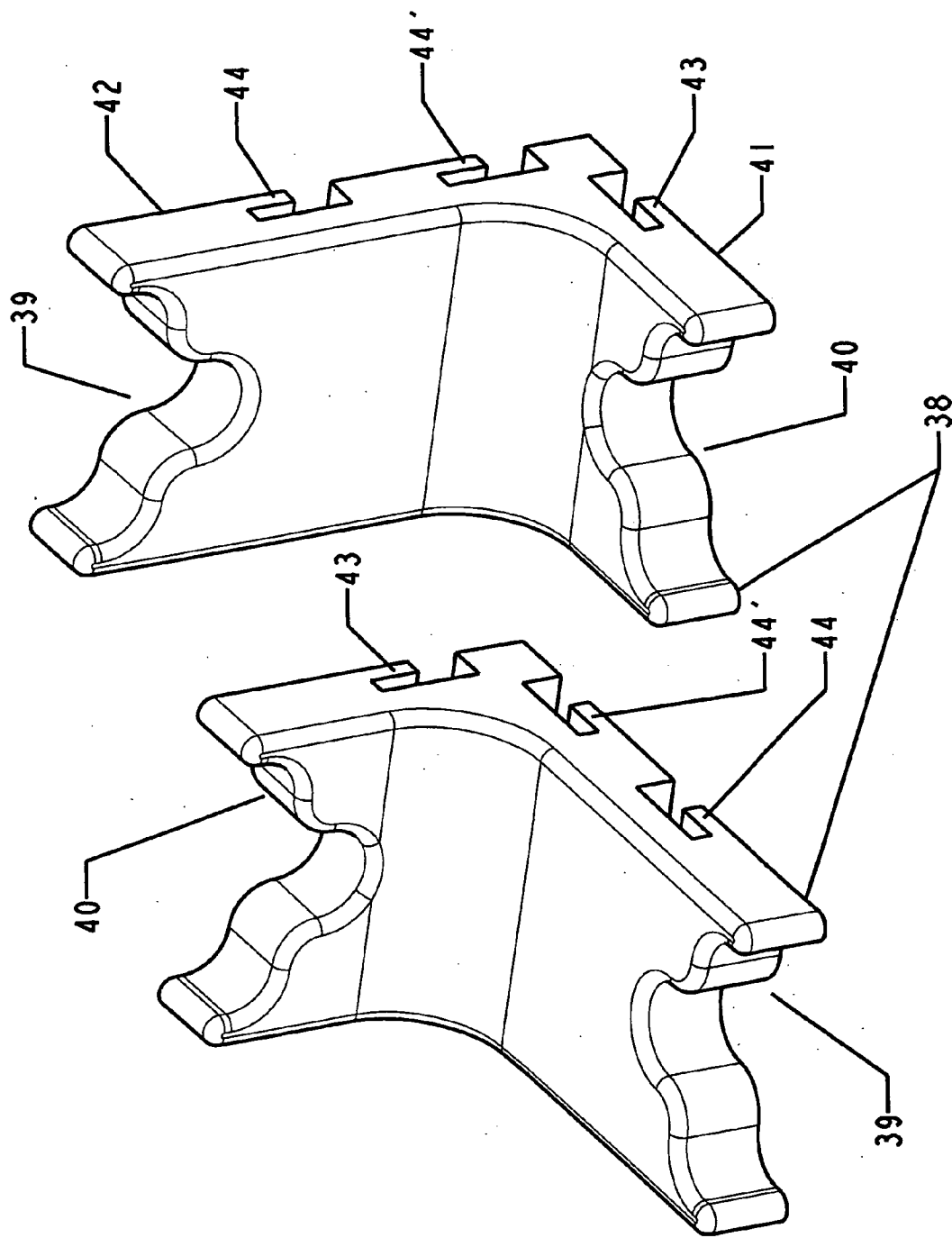

FIG. 2H

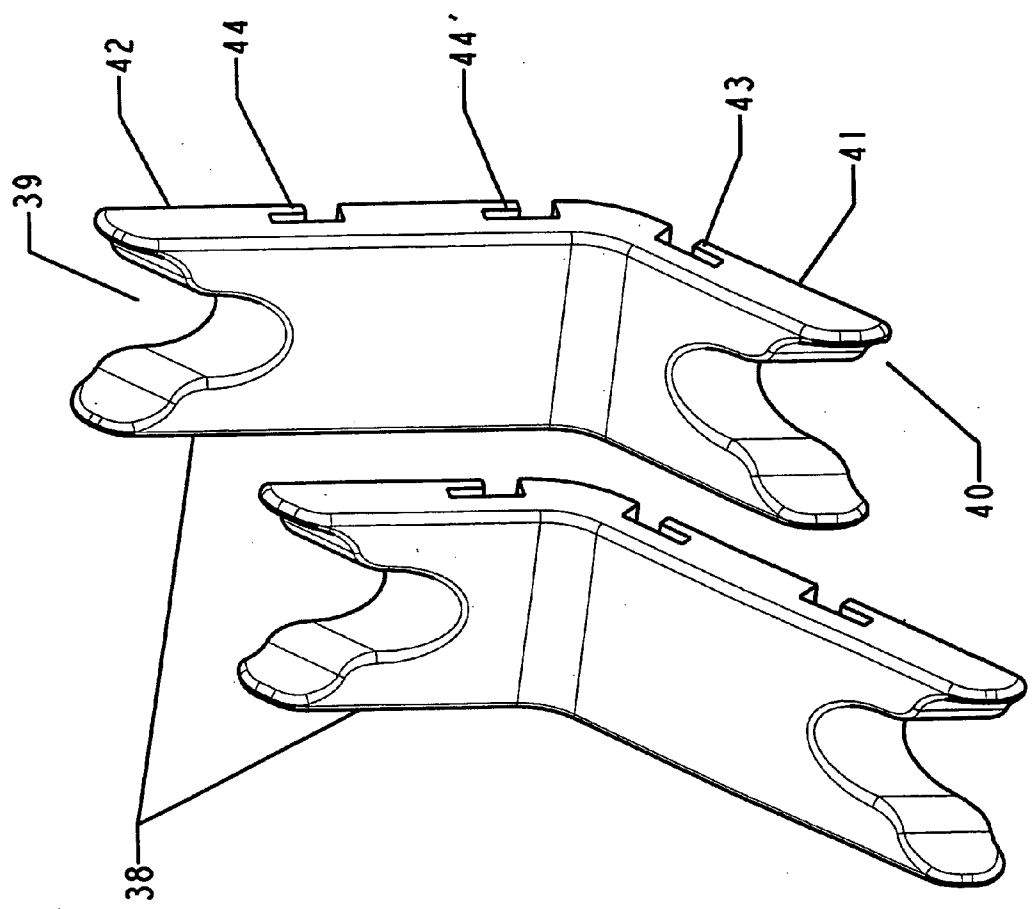

FIG. 21

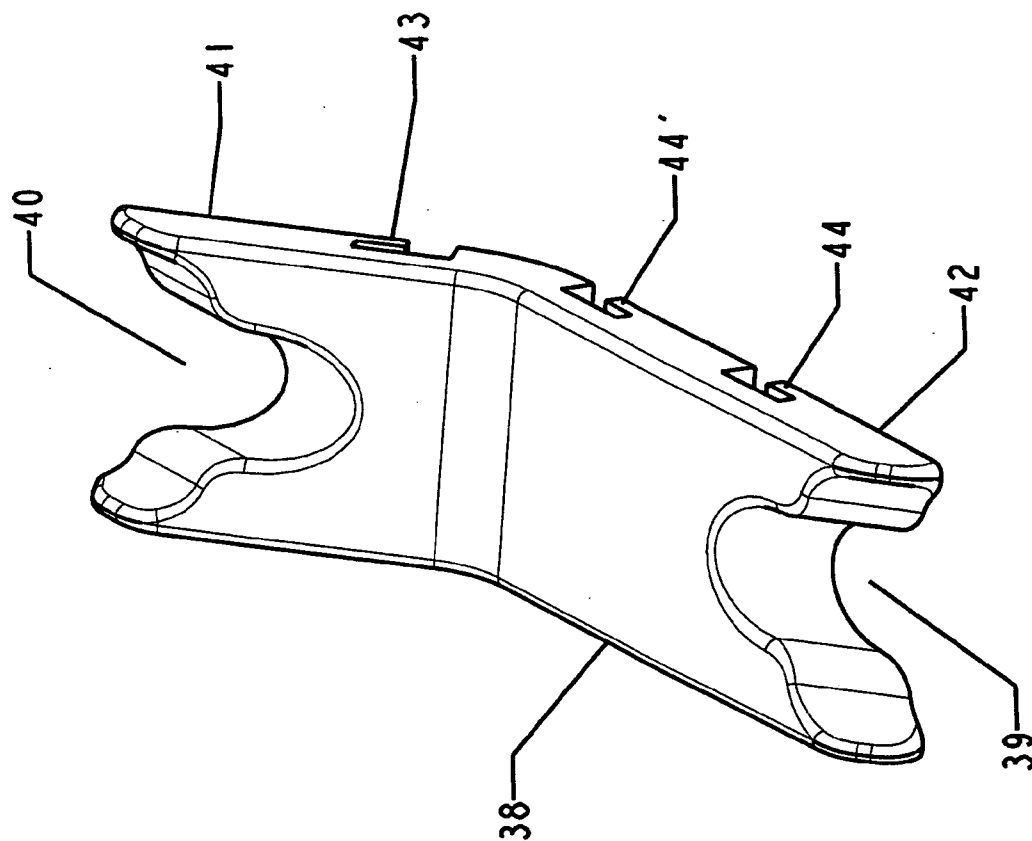

FIG. 2J

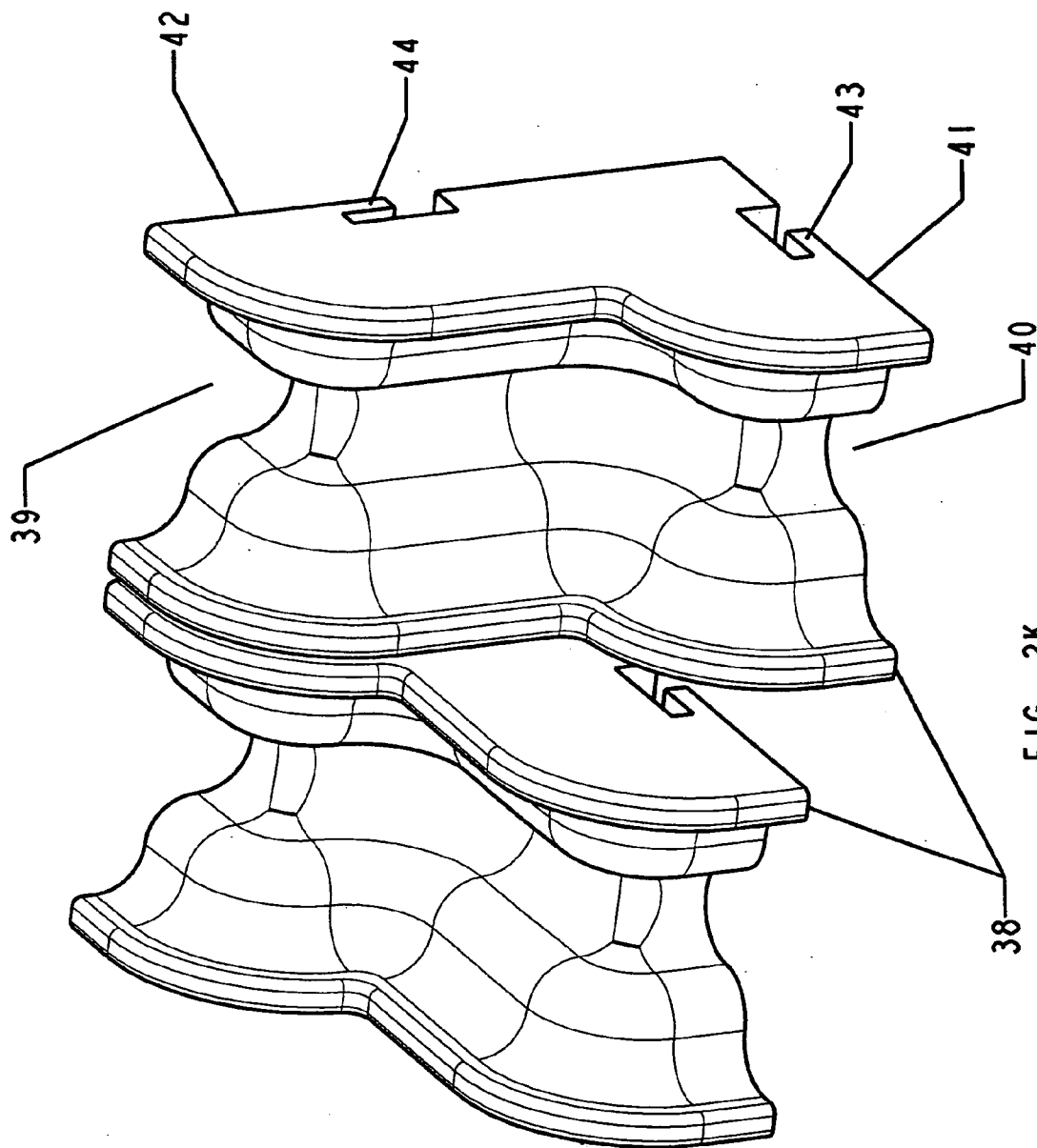

FIG. 2K

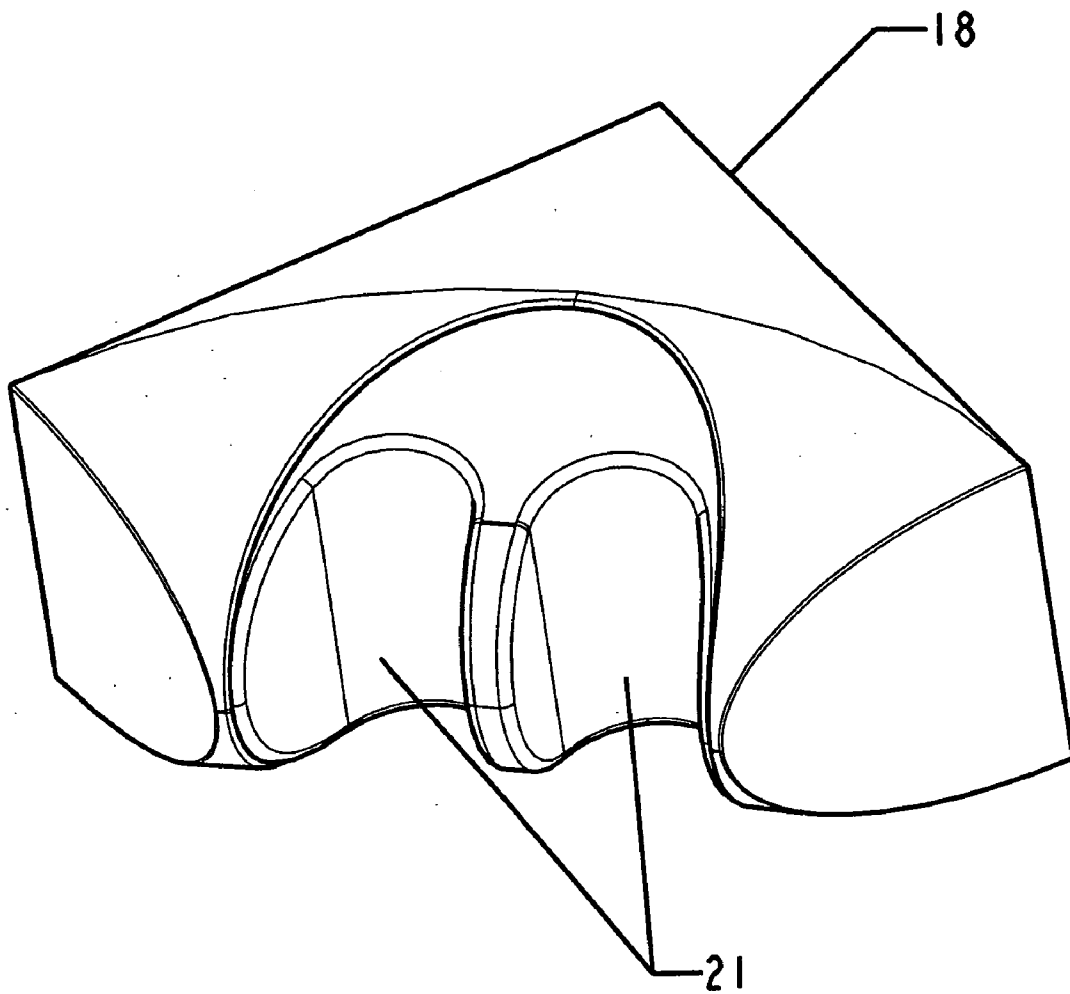

FIG. 3

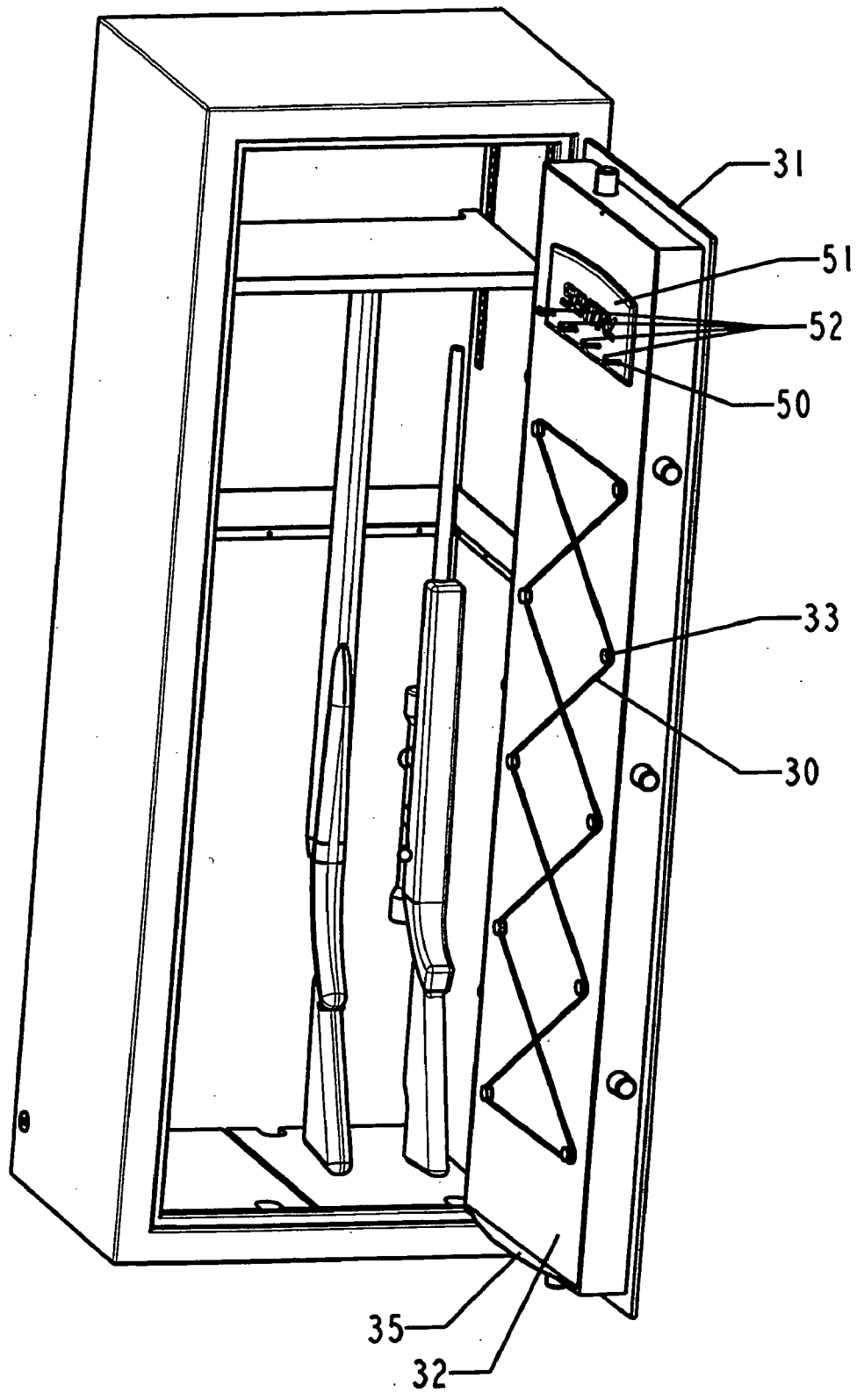

FIG. 4

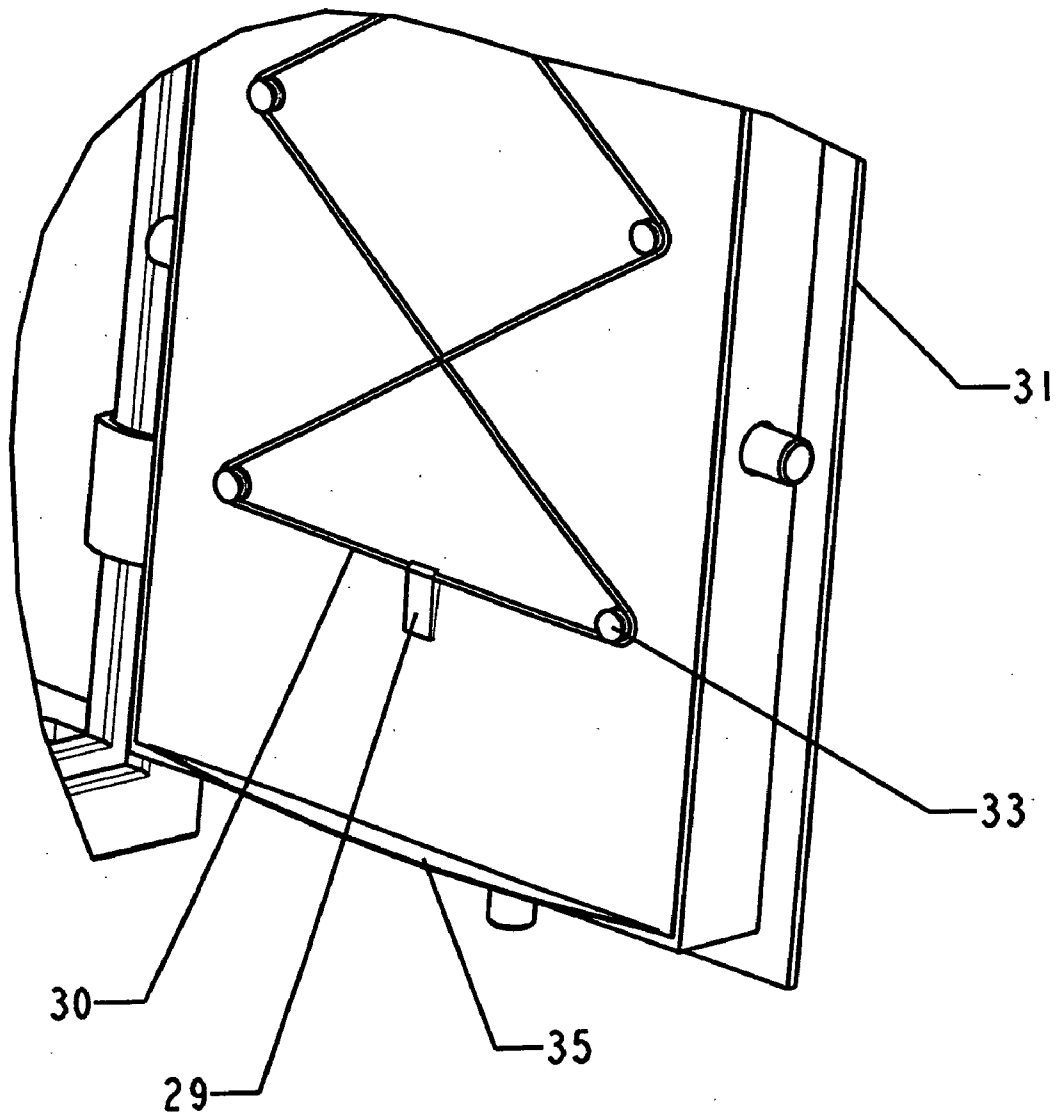

FIG. 4A

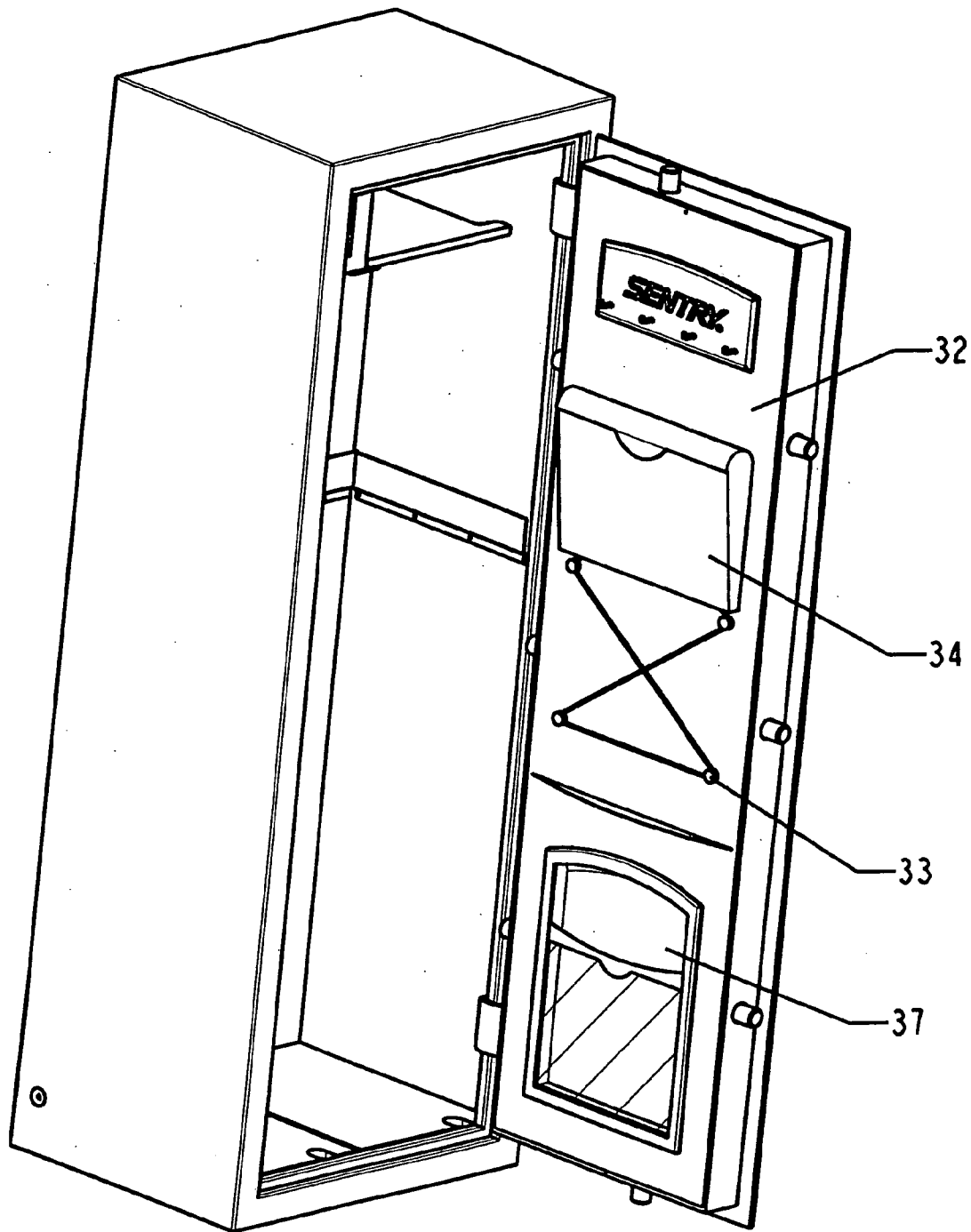

FIG. 5

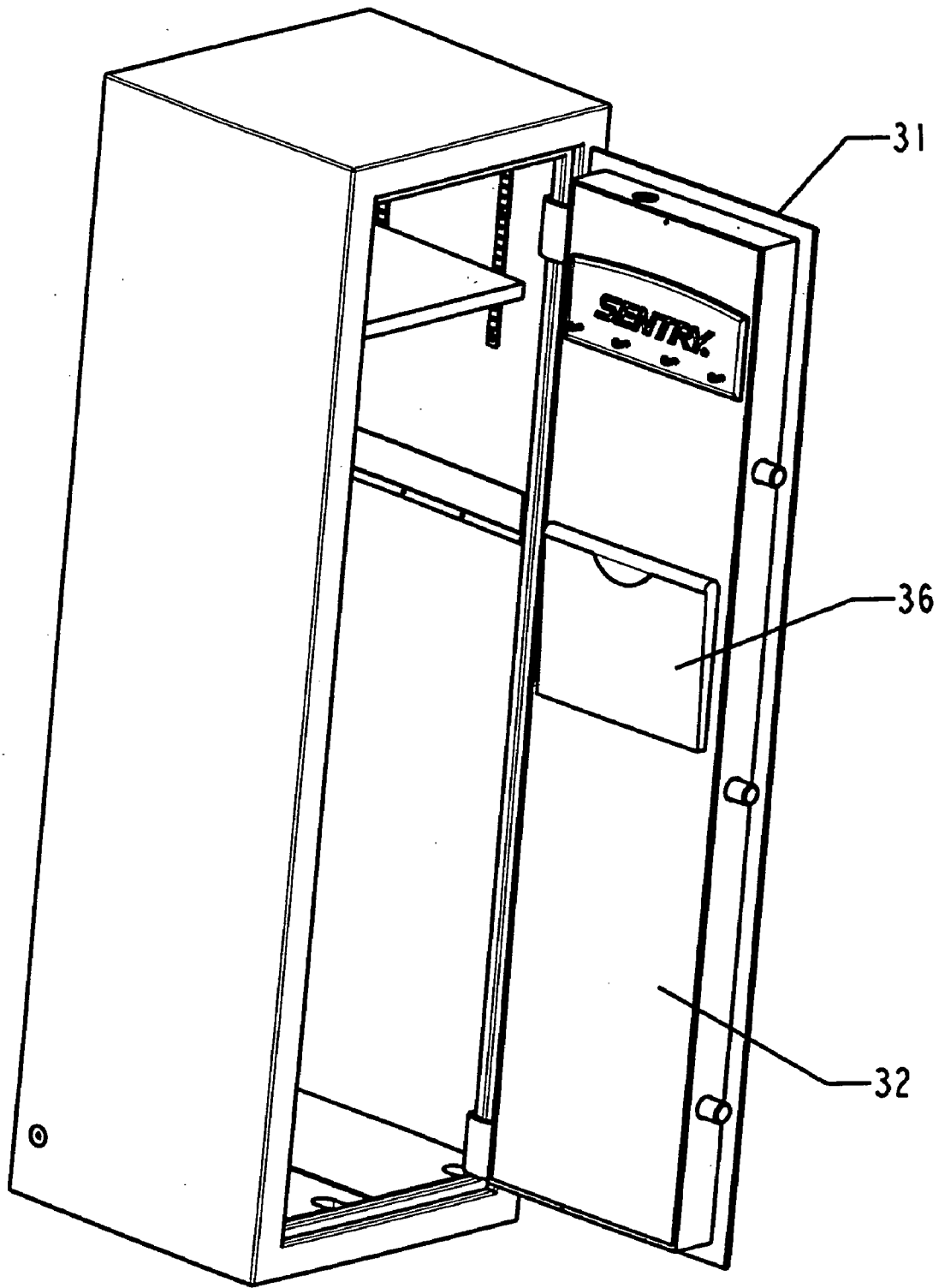

FIG. 6

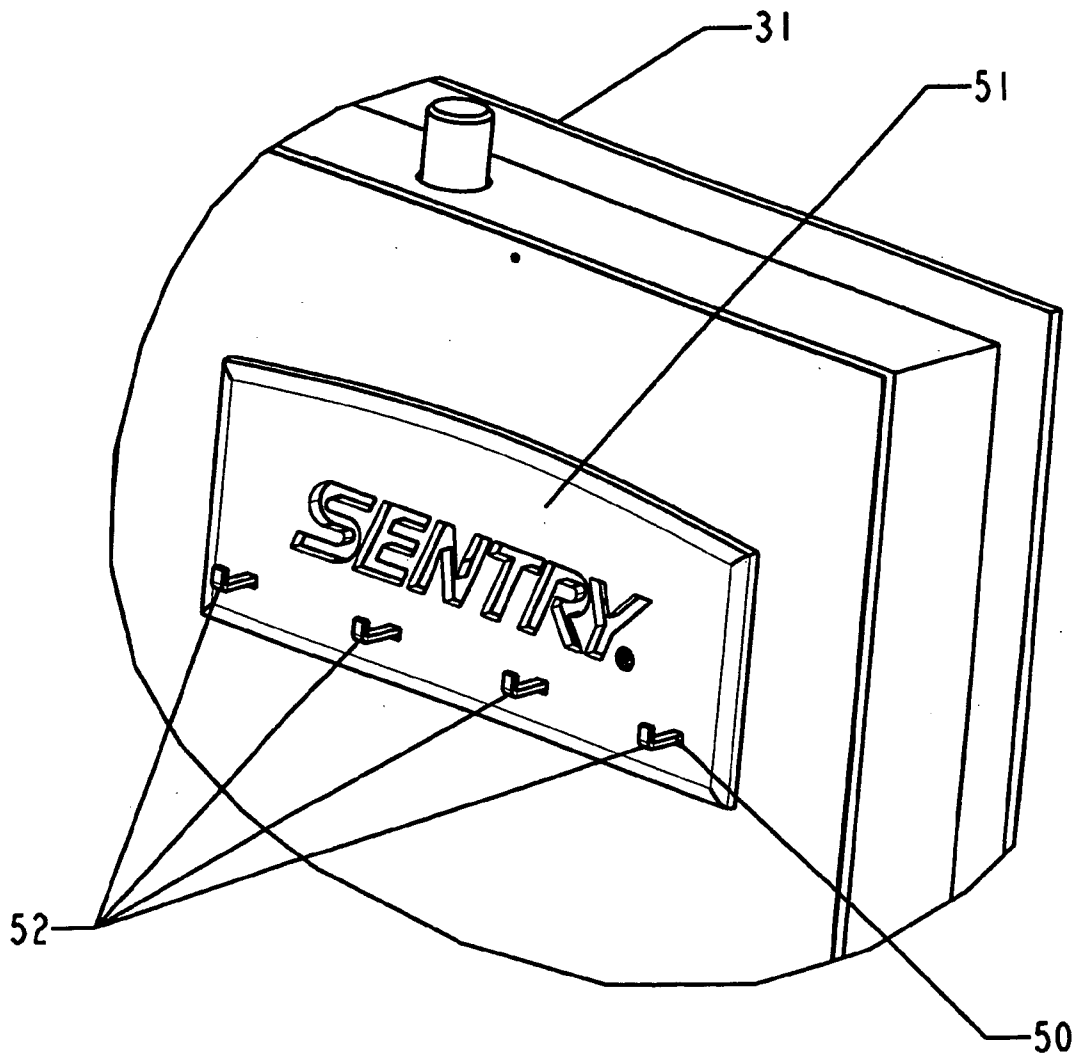

FIG. 7

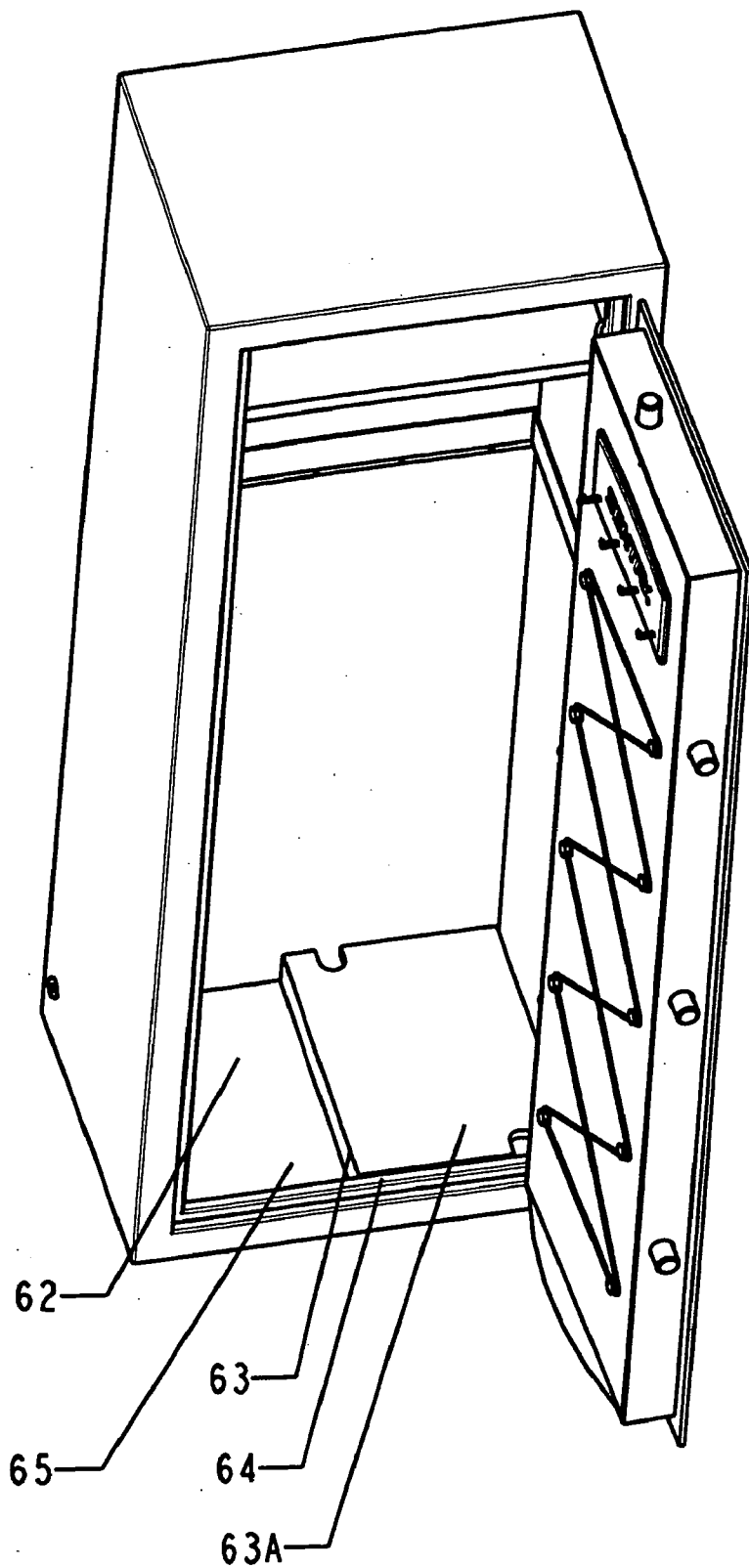

FIG. 8

GUN SAFE WITH CONFIGURABLE INTERIOR

CROSS-REFERENCE TO RELATED APPLICATIONS

[0001] This application claims priority from a U.S. Provisional Application having Serial No. 60/427,200, filed on Nov. 18, 2002.

STATEMENT REGARDING FEDERALLY SPONSORED RESEARCH OR DEVELOPMENT

[0002] Not applicable.

BACKGROUND OF THE INVENTION

[0003] The present invention relates to a gun safe with a configurable interior. More particularly, the present invention relates to a gun safe having a unique modular gun rack, a versatile interior door storage system, and removable floor/storage compartment.

[0004] When procuring a gun safe it is important to select a safe with a configuration that best serves the needs of the user. The results of utilizing a safe that is not configured to meet the specific requirements of its user can vary from poorly secured and mislaid valuables to excessive effort and time expended in storing and retrieving items. Moreover, inefficient spacing and difficulty in accessing and retrieving stored firearms can result in damage to the firearms caused by nicking or striking against each other or against the interior of the safe. Furthermore, even if the requirements of the user are satisfied at the time of acquisition, as the needs of the user change, very little can be done to alter the interior configuration of the safe in the present art.

[0005] To keep long guns arranged in an orderly row, conventional firearm safes provide non-movable firearm racks rigidly attached to the three interior walls of the safe. The firearm racks consist of a predetermined number of barrel receiving portions that protrude from the three interior walls into the safe. The racks define the number of long-arm guns that can be aligned against each wall and thereby, define and restrict utilization of the interior of the safe not occupied by the guns or occupied by guns having a peculiar shape. Additionally, it is desirable to store peripheral items, such as scopes, barrels, pistols, cleaning equipment and paperwork in the safe. Also, while conventional firearm safes sometimes provide fixed shelves where these peripheral items can be placed, stacking these items on the shelves prohibits easy access, resulting in excessive time expended to locate these items. Furthermore, the floor of conventional fire arm safes is below, and not flush with the door opening, thereby forming a lower lip. When removing guns from the safe having such a floor design, the butt portion often collides with this lower lip, thereby damaging the gun.

[0006] Accordingly, there exists a need for a configurable gun safe that ameliorates the aforementioned drawbacks and deficiencies. The present invention fills these needs as well as other needs.

BRIEF SUMMARY OF THE INVENTION

[0007] In order to overcome the above stated problems and limitations there is provided a safe having a unique modular gun rack, a versatile interior door storage system, and removable floor/storage compartment.

[0008] The modular gun rack of the present invention includes one or more individual barrel receiving modules secured to the internal walls by a "Z" shaped bracket. This novel bracket provides versatility in the lateral placement of the receiving modules and allows for the secure mounting of the receiving modules to the walls of the safe without the use of known retention methods such as with screws or bolts. The receiving modules are also designed to receive various shaped gun barrels and can accommodate guns with scopes attached.

[0009] Additionally, the inside of the safe door includes bungee cord elements and cinches. The length of bungee cord is held in place by a series of knobs attached to the inside of the door. The bungee cord and cinches hold peripheral items such as gun barrels, scopes, and paperwork against the inside of the door. Storage bags are also provided. Also, a unique floor is positioned flush with the door opening and is removable. The removable floor can be locked into place to provide an additional level of security for articles stored within the safe.

[0010] Additional objects, advantages and novel features of the present invention will be set forth in part in the description which follows, and will in part become apparent to those in the practice of the invention, when considered with the attached figures.

BRIEF DESCRIPTION OF THE SEVERAL VIEWS OF THE DRAWINGS

[0011] The accompanying drawings form a part of this specification and are to be read in conjunction therewith, wherein like reference numerals are employed to indicate like parts in the various views, and wherein:

[0012] FIG. 1 is a perspective view of a plurality of gun receiving modules and a corner receiving module according to the present invention;

[0013] FIG. 1b is a perspective view of a bracket that forms a part of the present invention;

[0014] FIG. 1c is a side elevational view of the bracket shown in FIG. 1b and one of the gun receiving modules shown in FIG. 1a;

[0015] FIG. 2a is a front perspective view of one of the gun receiving modules shown in FIG. 1a;

[0016] FIG. 2b is a rear perspective view of the gun receiving module shown in FIG. 2a;

[0017] FIG. 2c is a side elevational view of the gun receiving module shown in FIG. 2a;

[0018] FIG. 2d is a perspective view of an alternative embodiment of the gun receiving module shown in FIG. 2a;

[0019] FIG. 2e is a side elevational view of an extension module;

[0020] FIG. 2f is a side elevational view of another embodiment of a gun receiving module according to the present invention;

[0021] FIG. 2g is a front perspective view of the gun receiving module shown in FIG. 2f;

[0022] FIG. 2h is a front perspective view of yet another embodiment of a gun receiving module in accordance with the present invention;

[0023] FIG. 2i is a front perspective view of yet another embodiment of a gun receiving module in accordance with the present invention;

[0024] FIG. 2j is a front perspective view of the gun receive module shown in FIG. 2i;

[0025] FIG. 2k is a front perspective view of another embodiment of a gun receiving module in accordance with the present invention;

[0026] FIG. 3 is a front perspective view of the corner receiving module in accordance with the present invention;

[0027] FIG. 4 is a front perspective view of a safe showing the inside surface of its door including bungee cord elements and clinches in accordance with the present invention;

[0028] FIG. 4a is an enlarged view of the bottom portion of the safe door showing a bungee cord element and clinches positioned against the interior portion of a safe door;

[0029] FIG. 5 is a front perspective view showing a plurality of knobs for fastening storage compartment to a cover for a safe door;

[0030] FIG. 6 is a perspective view of a safe cover having storage bags coupled thereto;

[0031] FIG. 7 is an enlarged view of the inside of a safe door showing a plurality of hook mounted thereto; and

[0032] FIG. 8 is a perspective view of a removable safe floor in accordance with the present invention.

DETAILED DESCRIPTION OF THE INVENTION

[0033] Referring to FIG. 1a, in one embodiment series shown, the interior gun rack of the present invention has one or more individual barrel receiving modules 10' and a corner receiving module 18 secured to interior walls 11 on a "Z" shaped bracket 12. Module 10' includes a clip 13 for attaching the module to wall 11 and a cradle 14' for receiving a gun barrel (not shown). FIGS. 2d and 2f-2g show a series of second embodiments including arcuate shaped barrel receiving modules 10'. FIGS. 2h-2k show yet other shaped modules.

[0034] As best seen in FIG. 1c, attaching clip 13 on a back portion of receiving module 10' securely attaches the module to bracket 12. Clip 13 extends in a generally parallel direction relative to a rear wall 70 of the receiving module 10'. As best seen in FIG. 2a, cradle 14' is uniquely shaped to receive many different barrel types. Barrel receiving modules 10' may also include optional straps for securing the gun barrel against the cradle. Strap ends are secured to the module while connecting means of straps, such as for example, snaps or Velcro, are used to join the straps together once the gun barrel is in place in a respective cradle.

[0035] Referring now to FIGS. 1b and 1c, substantially rigid bracket 12 includes a first leg 45 and a second leg 46 connected by transition member 47 to thereby position second leg 46 parallel to but offset from first leg 45. First leg 45 of bracket 12 is secured to wall 11 of the safe by conventional attaching means 49 such as, for example, rivets, screw, bolts or welding. Second leg 46 of bracket 12 protrudes upward spaced from the wall 11 by transition

member 47, forming a groove 48 between second leg 46 and wall 11. As best seen in FIG. 1c, the novel method of securing the receiving module to the safe wall is shown. Thickness 20 of clip 13 is sized slightly less than thickness 26 of groove 48, while stock thickness 22 of bracket 12 is slightly less than gap 24 of clip 13. Thus, barrel receiving module 10' is mounted to wall 11 by simply sliding clip 13 of the barrel receiving module into the groove 48. This mechanism allows the barrel receiving module to be secured firmly against wall 11. However, unlike the means for securing the gun modules to the walls of the safe as known in the art, the present invention allows the receiving module to be positioned and re-positioned anywhere laterally along bracket 12 and along the walls of the safe to accommodate the number of guns stored and a variety of gun barrel shapes and designs.

[0036] Referring now to FIGS. 2a, 2b, and 2c, receiving module 10' includes cradle 14' for receiving the barrel of a gun, and clip 13, for securing the individual barrel receiving module to bracket 12. As discussed above, bracket 12 is fixedly mounted on the internal walls 11 of the safe and, in turn, individual barrel receiving modules 10' are attached to bracket 12 by clip 13. As best shown in FIG. 2a, cradle 14' includes a uniquely shaped concave recess to accommodate barrels of various gun types such as, but not limited to, double barrel, side-by-side, under and over, and the like. Cradle 14' may have a soft contact surface such as, for example, rubber to further protect the gun barrels from scratches or nicks. This soft contact surface can be either a separate piece or integrally attached or molded to the module 10'. While clip 13 is shown with three prongs spaced across the full width of the module in the above disclosed embodiments, it is contemplated that the clip of the present invention can instead include a single prong spaced across the width of the module.

[0037] When the guns are positioned "standing-on-end" as shown in FIG. 4, the top surfaces of the gun barrels are in close proximity to the safe walls. For guns with barrel mounted scopes, these alignment clearances could pose a problem. To accommodate guns outfitted with barrel mounted scopes, an extension is used to space the barrels a greater distance from the wall. One particular extension means is an extension module, having a coupling end and an extension cradle similar in contour to cradle 14'. The coupling end of the extension module is shaped to fit into the concave recess of cradle 14'. The extension module can be attached to receiving module 10' by a screw or screws, or by plastic spring clips and recesses molded into the modules. When the extension module attached to a receiving module, the cradle serves to position a received gun barrel a greater distance from the wall of the safe and thereby provides additional wall clearance for a barrel mounted scope.

[0038] Referring to FIG. 2e another embodiment for providing additional wall clearance for a barrel mounted scope is shown. Double clip extender 35 has a first extension clip 37 extending from a first side 72 and a extension second clip 36 extending from a second side 74. The first extension clip 37 is sized for inserting into groove 48 of bracket 12 and the second extension clip 36 is sized for receiving clip 13 of barrel receiving module 10'. Second extension clip 36 is a reverse or mirror image of first extension clip 37 so that double extender 35 can be oriented in either direction. Further, second extension clip 36 may also include a recess

portion that is adapted to be positioned adjacent to clip 13 of receiving module 10' when clip extender 35 is coupled with receiving module 10'. While in most cases, only one extender clip will be needed to provide enough wall clearance for the scope, two or more clip extenders can be piggy-backed together in this fashion to provide event greater wall-to-barrel clearance, as needed. It will be understood that another embodiment may be used to providing additional wall clearance for a barrel mounted scope. In particular, as best seen in FIG. 2d, receiving module 10" may also be elongated so that the cradle 14' is positioned further away from clip 13 compared to the receiving module 10' shown in FIG. 2a.

[0039] Referring to FIGS. 2f-2k various embodiments of reversible module 38 are shown. Module 38 has a first cradle 40 for receiving barrels without scopes and second cradle 39 for receiving barrels with scopes. The module has a short side 41 and a long side 42 generally perpendicular to the short side. Short side 41 and long side 42 each have a clip 43, 44, respectively, for attaching module 38 to bracket 12 as described above. When clip 44 is used to attach module 38 to bracket 12, cradle 40 for receiving a gun barrel without a scope is available for use. When clip 43 is used to attach module 38 to bracket 12, cradle 39 for receiving a gun barrel with a scope is available for use. Modules may have a secondary clip 44' on long side 42 for adjusting the vertical position of cradle 40.

[0040] Referring to FIG. 3, a unique corner barrel receiving module 18 contains two barrel receiving cradles 21, and may have a recess on an upper surface of corner barrel receiving module 18. The clip (not shown) is sized to be received by bracket 12 as described above, for corner module 18 to be positioned at intersecting corners of walls 11. In this manner, the corners of the safe can be efficiently utilized for the storage of guns. The recess may be suitable for holding aerosol cans or small objects that can be easily misplaced. It will be understood that, while corner module 18 in FIG. 3 is shown as a flat module in FIG. 1a, corner module 18 can also be formed as an arcuate module as in FIG. 2a.

[0041] It should also be noted that hooks and other universal hanging devices, having clips 13 as described above, can be easily hung on bracket 12 making the design even more versatile.

[0042] As best seen in FIGS. 4 and 4a, the inside surface of the safe door includes bungee cord elements and cinches for storing peripheral items such as gun barrels, scopes, and paperwork against the inside door panel. The inside of the safe door 31 has a length of bungee cord 30, criss-crossed against the door surface and held in place by a series of knobs 33. Cinch 29 is used to tighten the bungee cord as needed to secure the peripheral items in place. A lip 35 is formed in the bottom of the door surface to add additional support for long items held by the bungee cord 30. As best seen in FIG. 5, the knobs 33 can also serve as snaps or buttons, for fastening bags 34, to provide additional storage compartments. The knobs can also serve to hold the cover 32 on the door surface. Additionally, cover 32 can be formed of Velcro material for attaching pockets and other items equipped with Velcro fasteners. Referring to FIG. 6, the cover 32 can hold storage bags having Velcro fasteners 36. The combination of the Velcro and the bungee cord provides

a greater degree of support for items attached to the inside of the door. Additionally, the inside of the door 31 has optional recesses for receiving recess pockets 37 (FIG. 5). In this optional embodiment recess pockets 37 are mounted flush with the door surface.

[0043] Referring to FIG. 4 and FIG. 7, panel 51, which in the example shown also serves as a nameplate, includes a row of hooks 50, attached to the inside of door 31. This row of hooks 50 comprises hooks 52, rigidly mounted to panel 51. The hooks 52 may be used to hold straps, buckles, or other items.

[0044] The floor, or false bottom of the safe may be removable, and can be locked into place to provide an additional level of security for articles stored within the safe. As best seen in FIG. 8, the floor of the safe of the present invention has an additional storage compartment 62 which lies between cover panels 63 (only one shown), and the true bottom 65 of the safe. The cover panels (one shown as 63a) form a bottom of the safe, which is flush with the lower lip 64 of the door opening. Making the one or more cover panels 63 flush with the bottom edge of the access opening in the enclosure reduces the chance that a gun will catch on the lower lip of the safe when a gun is removed from the safe. Cover panels 63 can be carpeted or rubberized and, when in place, serve to conceal the contents stored below. A lock may also be provided to add further security and protection for the contents stored below cover panels 63.

[0045] While particular embodiments of the invention have been shown, it will be understood, of course, that the invention is not limited thereto, since modifications may be made by those skilled in the art, particularly in light of the foregoing teachings. Reasonable variation and modification are possible within the scope of the foregoing disclosure of the invention without departing from the spirit of the invention.

1. A configurable safe for storing firearms comprising:

a bracket adapted to be positioned on an interior surface of the safe; and

at least one barrel receiving module having at least one barrel receiving cradle for receiving a barrel of a gun and a clip for movably mounting the barrel receiving module to the bracket.

2. The configurable safe of claim 1, wherein said barrel receiving module includes a rear wall, wherein said clip extends from said rear wall.

3. The configurable safe of claim 1, wherein said clip extends generally parallel to said rear wall.

4. The configurable safe of claim 1, wherein said barrel receiving module further comprises an extension module.

5. The configurable safe of claim 4, wherein said extension module includes a coupling end, wherein said coupling end is adapted to be received in said barrel receiving cradle.

6. The configurable safe of claim 4, wherein said extension module includes first and second sides, wherein a first extension clip extends from said first side, and wherein a second extension clip extends from said second side.

7. The configurable safe of claim 6, wherein at least one of said first and second extension clips extends generally parallel to its respective side of said extension member.

8. The configurable safe of claim 7, wherein said first and second extension clips extend in opposite directions relative to each other.

9. The configurable safe of claim 1, wherein said bracket includes first and second legs, wherein said first leg is offset from said second leg.

10. The configurable safe of claim 9, wherein said bracket includes a transition member that offsets said first leg from said second leg.

11. The configurable safe of claim 9, wherein said first and second legs are parallel with one another.

12. The configurable safe of claim 1, further comprising a corner module having at least one barrel receiving cradle.

13. The configurable safe of claim 1, wherein said interior of said safe further comprises three interior walls.

14. The configurable safe of claim 1, further comprising:

a door with an internal surface, said internal surface of said door having one or more knobs attached thereto for retaining a bungee cord; and

a lip extending outward from said internal surface of said door for further supporting articles held by said bungee cord.

15. The configurable safe of claim 14, further comprising:

a combination nameplate and hook panel attached to said internal surface of said door, said combination nameplate and hook panel having a series of hooks mounted thereto.

16. The configurable safe of claim 1, further comprising:

a bottom storage compartment including at least one removable panel for concealing contents stored in said bottom storage compartment.

17. The configurable safe of claim 1, wherein said barrel receiving module is L-shaped.

18. The configurable gun safe of claim 1, wherein said gun barrel receiving module further includes a secondary clip for movably mounting the barrel receiving module to said bracket.

19. A gun rack module comprising:

at least one barrel receiving cradle for receiving a barrel of a gun; and

at least one a clip extending from a rear wall of the module, wherein said at least one clip extends from said rear wall.

20. The gun rack module of claim 19, wherein said at least one clip extends generally parallel to said rear wall.

21. The gun rack module of claim 19, wherein a second clip extends from a short side of the module, wherein the clip is generally parallel with the short side.

22. The gun rack module of claim 19, wherein the module includes two portions that are angled relative to one another.

23. The gun rack module of claim 22, wherein said module is L-shaped.

24. The gun rack module of claim 19, further including a secondary clip for movably mounting the barrel receiving module to said bracket.

25. A configurable storage compartment having a door with an internal surface, the storage compartment comprising:

one or more knobs attached to the internal surface of the door for retaining a bungee cord.

26. The configurable storage compartment of claim 25, further comprising:

a lip extending outwardly from the internal surface of the door for further supporting articles held by said bungee cord.

27. The configurable storage compartment of claim 26, further comprising:

a combination nameplate and hook panel attached to the internal surface of the door, said combination nameplate and hook panel having a series of hooks mounted thereto.

28. A storage compartment comprising:

a main housing having an access opening and a bottom floor, wherein said bottom floor is recessed relative to a lower edge of said access opening;

a door pivotally coupled with said main housing and adapted to occupy said opening in said main housing; and

one or more cover panels positioned over at least a portion of said bottom floor of said main housing to define a storage compartment between said bottom floor and said at least one cover panel, wherein said cover panel is generally flush with said lower edge of said access opening.

29. The storage compartment of claim 28, further comprising:

a locking mechanism associated with said cover plate to secure the second storage compartment.

* * * * *