



(12) **EUROPEAN PATENT APPLICATION**

(43) Date of publication: **10.12.2008 Bulletin 2008/50** (51) Int Cl.: **B02C 18/06 (2006.01)**

(21) Application number: **07109553.3**

(22) Date of filing: **04.06.2007**

(84) Designated Contracting States:  
**AT BE BG CH CY CZ DE DK EE ES FI FR GB GR HU IE IS IT LI LT LU LV MC MT NL PL PT RO SE SI SK TR**  
 Designated Extension States:  
**AL BA HR MK RS**

(71) Applicant: **F.HOFFMANN-LA ROCHE AG**  
**4070 Basel (CH)**

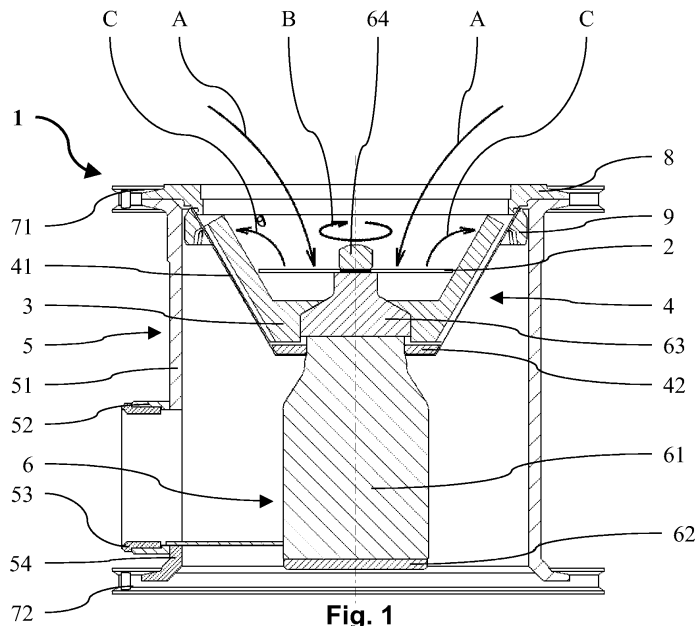
(72) Inventors:  
 • **Starck, Daniel**  
**68220 Attenschwiller (FR)**  
 • **Kuster, Pascal**  
**68470 Fellingring (FR)**

(74) Representative: **Bohest AG**  
**Postfach 160**  
**4003 Basel (CH)**

(54) **Plugging prevention device**

(57) A plugging prevention device (2) for a mill (1) having a hollow body (8) closed by a milling cup (4) in which a rotor (3) is rotatably arranged wherein the milling cup (4) has a bottom part (42) and a side-wall part (41) with openings, characterized in that the plugging prevention device (2) comprises a striking section and interconnecting means wherein the plugging prevention device (2) is arrangeable in the mill (1) such that the striking section at least partly covers the bottom part (42) of the milling cup (4) and such that the plugging prevention device (2) is torque proofly connected with the rotor (3) via the interconnecting means. In use, such a plugging prevention device (2) being arranged inside a mill (1) rotates together with the rotor (3) due to its torque proof connection with the rotor (3).

Thus, the milling good moving, for example flowing, into the direction of the bottom part (42) of the milling cup (4) hits onto the rotating striking section of the plugging prevention device (2). Thereby, centrifugal forces are transmitted to the milling good such that it is moved into the direction of the side-wall (41) part of the milling cup (4). At this side-wall (41) part it is affected by the rotator (3) and pressed through the openings of the side-wall part (41) of the milling cup (4). Additionally, when hitting onto the striking section of the plugging prevention device (2), lumps of milling good can be fractured such that essentially no lumps are present in the milling good while being pressed through the side-wall part (41) of the milling cup (4) by the rotator (3).



## Description

### Technical field

**[0001]** The present invention relates to a plugging prevention device according to the preamble of independent claim 1 and more particularly to a mill according to independent claim 9.

**[0002]** Such plugging prevention devices can be used for improving milling processes of mills having a hollow body closed by a milling cup in which a rotor is rotatably arranged wherein the milling cup has a bottom part and a side-wall part with openings.

### Background art

**[0003]** In various industrial or research fields, for example in chemical, pharmaceutical or food industry, processes include milling of various goods and substances. For example, in granulation processes a source material is often mixed with a binder in a mixer. Thereafter, wet mills can be used for milling said mixture previous of drying the mixture, e.g. in a fluidized-bed dryer. Such wet mills, as also being used in various different applications, can comprise a hollow body, for example having the shape of a hollow cylinder, which is closed at its bottom end by a milling cup. The milling cup usually has a side-wall part with a plurality of openings and a bottom part closing the milling cup in a downward direction. Typically, inside the milling cup a rotator is mounted. The mill can additionally have a housing surrounding the milling cup in which a drive can be arranged for rotating the rotator wherein the drive is connected to the rotator.

**[0004]** In use, the milling good can be fed into the hollow body at a top part of the wet mill. There starting, the milling good flows down into the direction of the milling cup typically by means of gravitation. Then, the rotating rotator moves the milling good onto the side-wall part of the milling cup having openings such that it is pressed through the openings of the side-wall part. The milling good being pressed through the openings can be gathered inside the housing and transferred to following processing steps such as for example to the fluidized-bed dryer.

**[0005]** In mills, for example in wet mills as described above, plugging can occur in the mill reducing the efficiency of the milling wherein such plugging effects depend on the properties of the milling good and the arrangement of the mill. Further, lumps of milling good are often built in such mills. Lumps can enhance plugging effects in mills such that the milling efficiency is additionally reduced. In particular, in cases where mills with milling cups are used as described above, the milling good including its lumps can be retained by the bottom part of the milling cup before being pressed through the openings of the side-wall part of the milling cup by the rotator. This can cause an accumulation of the milling good inside the mill until the mill is more or less completely stuck. At

this stage the rotator moves parts of the accumulated milling good around the milling cup without substantially pressing any milling good out of the openings of the side-wall part of the milling cup.

**[0006]** Therefore, there is a need for a device being capable of preventing plugging of milling good inside mills to allow a more efficient milling.

### Disclosure of the invention

**[0007]** According to the invention this need is settled by a plugging prevention device as it is defined by the features of independent claim 1, and by a mill as it is defined by independent claim 9. Preferred embodiments are subject of the dependent claims.

**[0008]** In particular, the invention deals with a plugging prevention device for a mill, in particular a wet mill, having a hollow body closed by a milling cup in which a rotor is rotatably arranged wherein the milling cup has a bottom part and a side-wall part with openings. The plugging prevention device comprises a striking section and interconnecting means wherein the plugging prevention device is arrangeable in the mill such that the striking section at least partly covers the bottom part of the milling cup and such that the plugging prevention device is torque proofly connected with the rotor via the interconnecting means. The term "cover" in this context relates to covering with respect to the regular direction of flow of the milling good such that, in use of the plugging prevention device, a milling good can not directly move onto the bottom part of the milling cup. It also includes covering the bottom part of the milling cup only while the striking section is rotating such that the striking section can also be shaped in such a manner that its geometric area of rotation covers the bottom part of the milling cup.

**[0009]** In use, such a plugging prevention device according to the invention being arranged inside a mill rotates together with the rotator due to its torque proof connection with the rotator. Such rotation can for example be performed at about seven hundred rounds per minute. Thus, the milling good moving, for example flowing, into the direction of the bottom part of the milling cup hits onto the rotating striking section of the plugging prevention device. Thereby, centrifugal forces are transmitted to the milling good such that it is moved into direction of the side-wall part of the milling cup. At this side-wall part it is affected by the rotator and pressed through the openings of the side-wall part of the milling cup. Additionally, when hitting onto the striking section of the plugging prevention device, lumps of milling good can be fractured such that essentially no lumps are present in the milling good while being pressed though the side-wall part of the milling cup by the rotator.

**[0010]** The striking section of the plugging prevention device can be provided with a coarse surface facing the milling good such that the centrifugal forces can efficiently be transmitted to the milling good. Further, the surface facing the milling good of striking section of the plugging

prevention device can be provided with cutting tools for improving the fracturing of lumps.

**[0011]** Preferably, the striking section completely covers the bottom part of the milling cup. Such a striking section allows essentially to prevent a movement of milling good onto the bottom part of the milling cup even if the rotator rotates at a comparable low speed.

**[0012]** The interconnecting means preferably comprises a profiled receiver. With such a receiver the torque proof connection between the plugging prevention device and the rotator can easily be provided. For example, the receiver can be shaped as a squared through hole such that the squared through hole can be mounted on a corresponding squared part of a rotational axle.

**[0013]** In a first preferred embodiment of the plugging prevention device according to the invention, the striking section comprises a circular disk. Such a striking section provides a comparably large area where the milling good can hit on such that fracturing of lumps in the milling good can be optimized. Further, such a plugging prevention device is comparably easy to manufacture.

**[0014]** Preferably, the disk has through holes such as for example four equally distributed circular through holes. Such through holes improve accessibility of the space between the plugging prevention device and the milling cup while the plugging prevention device is not rotating. This can for example be an advantage for cleaning the mill, in particular for exhausting milling good out of the space between the plugging prevention device and the milling cup.

**[0015]** The disk preferably has recesses at its outer edge projecting into the direction of the center of the disk. Such recesses can further improve accessibility of the space between the plugging prevention device and the milling cup.

**[0016]** In a second preferred embodiment of the plugging prevention device according to the invention, the striking section comprises a circular cone wherein the tip of the cone preferably faces away from the bottom part of the milling cup. By means of the slanted area of the striking section, the milling good hitting the striking section can additionally be moved towards the side-wall part of the milling cup. Thus, with such a circular cone the centrifugal movement of the milling good into direction of the side-wall part of the milling cup can be improved.

**[0017]** In a third preferred embodiment of the plugging prevention device according to the invention, the striking section comprises a circular truncated cone. With such an arrangement of the striking section the advantages of the above described arrangements of a circular cone and of a circular disk can be combined.

**[0018]** A second aspect of the invention deals with a mill, such as for example a wet mill, having a hollow body closed by a milling cup in which a rotor is rotatably arranged wherein the milling cup has a bottom part and a side-wall part with openings. In the mill a plugging prevention device as described above is arranged such that the striking section of the plugging prevention device at

least partly covers the bottom part of the milling cup and such that the plugging prevention device is torque proofly connected with the rotor via the interconnecting means. As described above with respect to the plugging prevention device, with such a mill and a plugging prevention device the centrifugal movement of the milling good into the direction of the side-wall part of the milling cup can be improved as well as the fracturing of lumps of milling good can be improved. Like this, a more efficient milling is possible.

**[0019]** Preferably the rotor is connected with further interconnecting means corresponding to the interconnecting means of the plugging prevention device and the further interconnecting means are interlocked with the interconnecting means of the plugging prevention device. Such an arrangement allows a comparably easy arrangement of a torque proof connection between the rotator and the plugging prevention device. For example, the further interconnecting means can be arranged at a rotational axle.

**[0020]** The plugging prevention device is preferably arranged inside the milling cup. Thereby, a compact arrangement of the mill according to the invention is possible.

**[0021]** Preferably, the plugging prevention device is arranged spaced from the bottom part of the milling cup. Like this, the arrangement of the mill can be optimized with respect to the properties of the milling good and the application of the mill. In particular, since the side-wall part of the milling cup is usually conically shaped, the striking section can be enlarged with increasing distance from the bottom part of the milling cup. Thus, the distance can be optimized such that size of the striking section can be as large as possible without essentially covering the side-wall part of the milling cup.

Brief description of the drawings

**[0022]** The plugging prevention device according to the invention and the mill according to the invention are described in more detail hereinbelow by way of exemplary embodiments and with reference to the attached drawings, in which:

**[0023]** Fig. 1 shows a cross sectional side view of a mill according to the invention with a first embodiment of a plugging prevention device according to the invention;

**[0024]** Fig. 2 shows a top view on the plugging prevention device from of the mill from Fig. 1;

**[0025]** Fig. 3 shows a top view on a second embodiment of a plugging prevention device according to the invention;

**[0026]** Fig. 4 shows a top view on a third embodiment of a plugging prevention device according to the invention;

**[0027]** Fig. 5 shows a top view on a fourth embodiment of a plugging prevention device according to the invention;

**[0028]** Fig. 6 shows a side view on the plugging pre-

vention device from Fig. 5;

**[0029]** Fig. 7 shows a top view on a fifth embodiment of a plugging prevention device according to the invention; and

**[0030]** Fig. 8 shows a side view on the plugging prevention device from Fig. 7.

Mode(s) for carrying out the invention

**[0031]** In the following description certain terms are used for reasons of convenience and are not to be interpreted as limiting. The terms "down", "below", "lower", "upper", "top", "bottom", "central", "horizontal" and "vertical" refer to directions in the figures. The terminology comprises the explicitly mentioned terms as well as their derivations and terms with a similar meaning.

**[0032]** In Fig. 1 a lower section of a wet mill 1 is shown having a hollow body 8 being connected to a housing 5 at its lower end. The housing 5 comprises a cylindrical body portion 51 having a horizontal engine adapter 52 at its lower end region. The engine adapter 52 is connected to horizontal engine connecting means 53 to which an engine is connected for driving the wet mill 1. Further, the housing 5 has a frame adapter 54 wherein the housing 5 is connected to a bottom frame 72 via the frame adapter 54. The connection between the housing 5 and the hollow body 8 is arranged by means of an annular top frame 71. Inside the body portion 51 of the housing 5 a milling cup 4 is additionally connected to the hollow body 8 by means of a mounting ring 9 such that the milling cup 4 lies centrally below the hollow body 8. The milling cup 4 has a conical side-wall part 41 with a plurality of openings (not shown in Fig. 1) and horizontally arranged flat bottom part 42.

**[0033]** In addition to the milling cup 4 a pivot bearing 6 is centrally arranged inside the body portion 51 of the housing 5. The pivot bearing 6 is connected to the engine such that the engine rotates the pivot bearing 6 when operating. Further, the pivot bearing 6 comprises a bottom 62 and a central section 61 wherein the central section 61 centrally extends through the bottom part 42 of the milling cup 4. Thereby, the central section 61 is fixedly and sealingly connected to the bottom part 42 of the milling cup 4. Inside the milling cup 4 a rotor 3 is arranged being bracket-shaped corresponding to the side-wall part 41 and the bottom part 42 of the milling cup 4 such that the rotor 3 lies slightly spaced from the side-wall part 41 and the bottom part 42. To the rotor 3 a rotating adapter 63 of the pivot bearing 6 is torque proofly mounted wherein the rotating adapter 63 is arranged on top of the central section 61 of the pivot bearing 6 inside the milling cup 4. On top of the rotating adapter 63 a plugging prevention device 2 is arranged wherein the plugging prevention device 2 is torque proofly connected to the rotating adapter 63 and thereby also to the rotor 3. The plugging prevention device 2 is fixedly mounted on the rotating adapter 63 by means of a fixation 64.

**[0034]** As best seen in Fig. 2, the plugging prevention

device 2 comprises a circular disk 21 as striking section having a centrally arranged receiver 22 as interconnecting means. The receiver 22 is shaped as a squared through hole being arranged on an rotational axle (not visible in the Figs.) of the pivot bearing 6 being shaped correspondingly squared.

**[0035]** In use, a milling good is fed into the wet mill 1 such that it vertically flows top-down through the hollow body 8. At the bottom part of the hollow body 8 where it is connected to the milling cup 4, the milling good either flows directly on the side-wall part 41 of the milling cup 4 or it flows onto the disk 21 of the plugging prevention device 2 as indicated by arrows A. The rotor 3 together with the plugging prevention device 2 are rotated by means of the engine via the pivot bearing 6 as indicated by arrow B. Thereby, on one hand the part of the milling good directly flowing to the side-wall part 41 of the milling cup 4 is pressed through the through holes of the side-wall part 41 by means of the rotating rotor 3. On the other hand, centrifugal forces are transferred to the milling good flowing onto the disk 21 of the plugging prevention device 2 such that it bounces back into the direction of the side-wall part 41 of the milling cup 4 as indicated by arrows C. There, the milling good is again pressed through the openings of the side-wall part 41 of the milling cup 4 by means of the rotating rotor 3. Thus, all milling good is efficiently delivered to the side-wall part 41 of the milling cup 4 and the part of milling good flowing onto the bottom part 42 of the milling cup 4 can be minimized.

**[0036]** Additionally, lumps being formed in the milling good are fractured when hitting the disk 21 of the plugging prevention device 2 such that the rotor 3 is capable of efficiently pressing essentially all milling good through the openings of the side-wall part 41 of the milling cup 4. After being pressed through the openings of the side-wall part 41 of the milling cup 4, the milling good is gathered and transferred downwardly out of the wet mill 1. These effects described above together allow the prevention of plugging inside the wet mill 1 during its use such that an efficient milling is possible.

**[0037]** The following applies to the rest of this description. If, in order to clarify the drawings, a figure contains reference signs which are not explained in the directly associated part of the description, then it is referred to previous description sections.

**[0038]** Fig. 3 shows a plugging prevention device 29 comprising a circular disk 219 as striking section having a centrally arranged receiver 229 as interconnecting means. As described above, the receiver 229 is shaped as a squared through hole being arrangeable on a corresponding rotational axle (not shown in the Figs.) of the pivot bearing 6 of the wet mill 1. Additionally, the disk 219 has four circular through holes 239 being equally distributed over the disk 219. Such through holes 239 allow an efficient cleaning of the milling cup 4 of the wet mill 1 after being used. In particular, milling good being arranged between the bottom part 42 of the milling cup 4 and the disk 219 of the plugging prevention device 29 can easily

be accessed, for example by exhausting. Anyhow, since the disk 219 is rotating during milling, essentially no milling good can flow through the through holes 239 in the space between the bottom part 42 of the milling cup 4 and the disk 219 of the plugging prevention device 29.

**[0039]** Another arrangement of a plugging prevention device 28 having a similar effect with respect to cleaning is shown in Fig. 4. The plugging prevention device 28 has a disk 218 and a centrally arranged receiver 228 being shaped as a squared through hole. The disk 21 further comprises four recesses 238 at its outer edge projecting into the direction of the center of the disk 218. Similar as described above, such recesses 238 allow an efficient cleaning of the milling cup 4 of the wet mill 1 after being used.

**[0040]** In Fig. 5 and in Fig. 6 a plugging prevention device 27 is shown having a circular cone 217 as striking section. Being arranged in the wet mill 1, the plugging prevention device 27 is preferably arranged such that the tip of the circular cone 217 extends upwardly. Thereby, the slanted area of the cone 217 assists the milling good to be moved towards the side-wall part 41 of the milling cup 4. Thus, with such plugging prevention device 27 the centrifugal movement of the milling good starting at the plugging prevention device 27 can be improved. This can be particularly advantageous in cases where the centrifugal forces are not satisfying for moving the milling good from the plugging prevention device 27 to the side-wall part 41 of the milling cup 4, which can occur for example if the rotation is comparably slow or if the weight of the milling good is comparably high.

**[0041]** Fig. 7 and Fig. 8 show a plugging prevention device 26 having a centrally arranged receiver 226 being shaped as a squared through hole and a striking section. The striking section comprises an inner disk section 226 surrounded by an outer circular truncated cone section 216 wherein the receiver 236 is centrally arranged at the disk section 226. With such an arrangement the advantages of the above described embodiments of plugging prevention device can be combined. In particular, the disk section 226 allows an advantageous fracturing of lumps in the milling good hitting the plugging prevention device 26 wherein the truncate cone section allows an advantageous centrifugal movement of the milling good hitting the plugging prevention device 26.

## Claims

1. Plugging prevention device (2; 26; 27; 28; 29) for a mill (1) having a hollow body (8) closed by a milling cup (4) in which a rotor (3) is rotatably arranged wherein the milling cup (4) has a bottom part (42) and a side-wall part (41) with openings, **characterized in that** the plugging prevention device (2; 26; 27; 28; 29) comprises a striking section (21; 216; 226; 217; 218; 219) and interconnecting means (22; 236; 228; 229) wherein the plugging prevention de-

vice (2; 26; 27; 28; 29) is arrangeable in the mill (1) such that the striking section (21; 216; 226; 217; 218; 219) at least partly covers the bottom part (42) of the milling cup (4) and such that the plugging prevention device (2; 26; 27; 28; 29) is torque proofly connected with the rotor (3) via the interconnecting means (22; 236; 228; 229).

2. The plugging prevention device (2; 26; 27; 28; 29) of claim 1, wherein the striking section (21; 216; 226; 217; 218; 219) completely covers the bottom part (42) of the milling cup (4).

3. The plugging prevention device (2; 26; 27; 28; 29) of claim 1 or 2, wherein the interconnecting means comprises a profiled receiver (22; 236; 228; 229).

4. The plugging prevention device (2; 26; 27; 28; 29) of any one of claims 1 to 3, wherein the striking section (21; 216; 226; 217; 218; 219) comprises a circular disk (21; 226; 218; 219).

5. The plugging prevention device (2; 26; 27; 28; 29) of claim 4, wherein the disk (21; 226; 218; 219) has through-holes (239).

6. The plugging prevention device (2; 26; 27; 28; 29) of claim 4 or 5, wherein the disk (21; 226; 218; 219) has recesses (238) at its outer edge projecting into the direction of the center of the disk (21; 226; 218; 219).

7. The plugging prevention device (2; 26; 27; 28; 29) of any one of claims 1 to 3, wherein the striking section (21; 216; 226; 217; 218; 219) comprises a circular cone (217).

8. The plugging prevention device (2; 26; 27; 28; 29) of any one of claims 1 to 5, wherein the striking section (21; 216; 226; 217; 218; 219) comprises a circular truncated cone (216, 226).

9. Mill (1) having a hollow body (8) closed by a milling cup (4) in which a rotor (3) is rotatably arranged wherein the milling cup (4) has a bottom part (42) and a side-wall part (41) with openings, **characterized in that** a plugging prevention device (2; 26; 27; 28; 29) according to any one of claims 1 to 8 is arranged in the mill (1) such that the striking section (21; 216; 226; 217; 218; 219) of the plugging prevention device (2; 26; 27; 28; 29) at least partly covers the bottom part (42) of the milling cup (4) and such that the plugging prevention device (2; 26; 27; 28; 29) is torque proofly connected with the rotor (3) via the interconnecting means (22; 236; 228; 229).

10. The mill (1) of claim 9 wherein the rotor (3) is connected with further interconnecting means corre-

sponding to the interconnecting means (22; 236; 228; 229) of the plugging prevention device (2; 26; 27; 28; 29) and wherein the further interconnecting means are interlocked with the interconnecting means (22; 236; 228; 229) of the plugging prevention device (2; 26; 27; 28; 29). 5

**11.** The mill (1) of claim 9 or 10, wherein the plugging prevention device (2; 26; 27; 28; 29) is arranged inside the milling cup (4). 10

**12.** The mill (1) of any one of claims 9 to 11, wherein the plugging prevention device (2; 26; 27; 28; 29) is arranged spaced from the bottom part (42) of the milling cup (4). 15

20

25

30

35

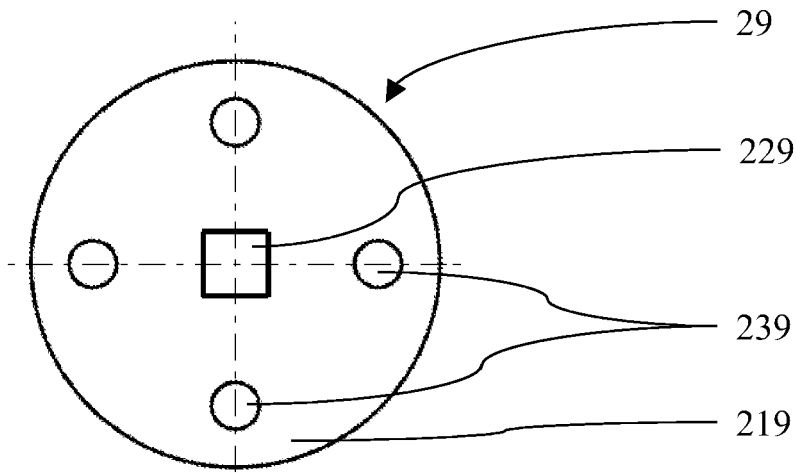
40

45

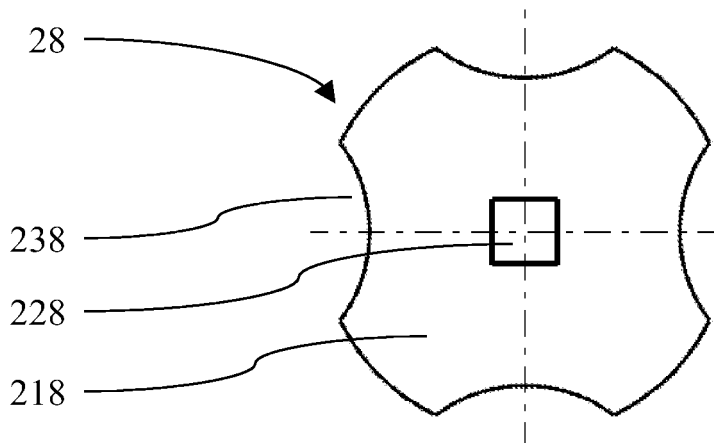
50

55

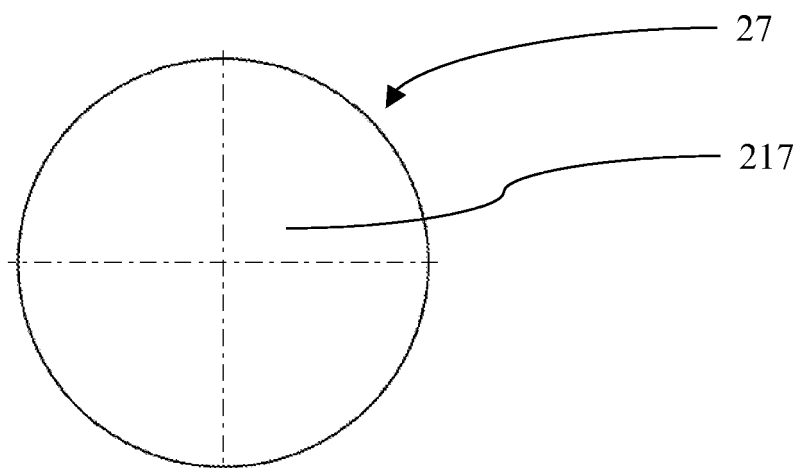




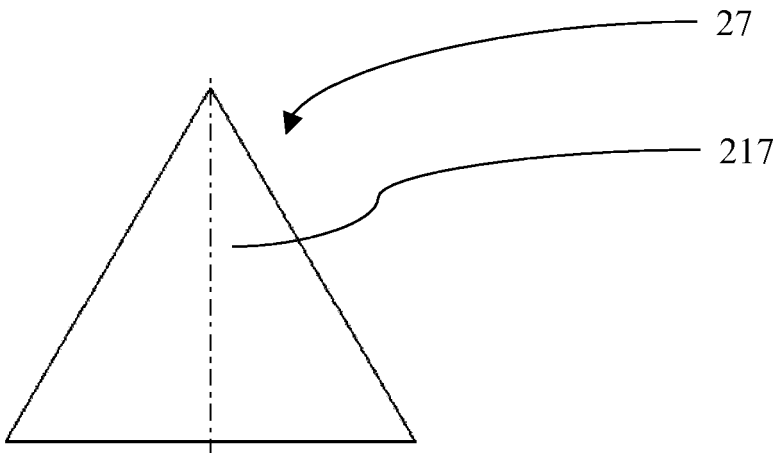
**Fig. 3**



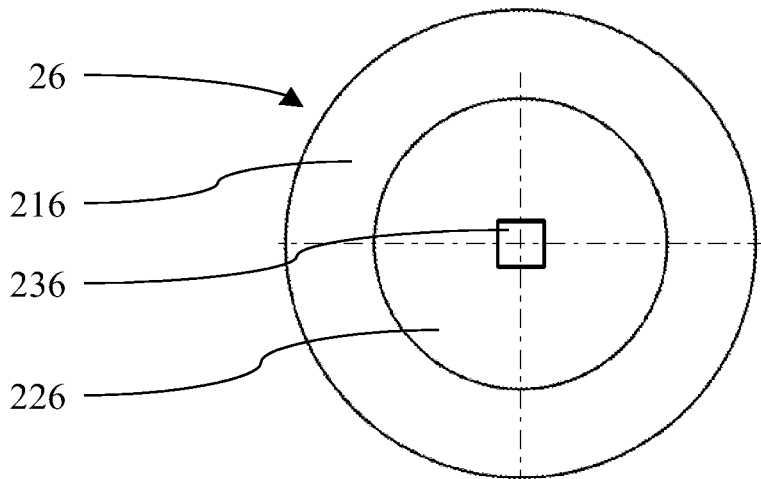
**Fig. 4**



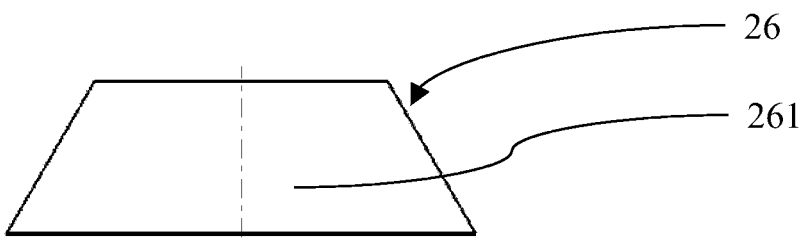
**Fig. 5**



**Fig. 6**



**Fig. 7**



**Fig. 8**



DOCUMENTS CONSIDERED TO BE RELEVANT			
Category	Citation of document with indication, where appropriate, of relevant passages	Relevant to claim	CLASSIFICATION OF THE APPLICATION (IPC)
X	US 5 544 821 A (GUPTA RAJENDRA P [CA] ET AL) 13 August 1996 (1996-08-13) * column 2, line 38 - line 63 * * column 3, line 61 - column 4, line 18 * * figures * -----	1-5,9-12	INV. B02C18/06
X	US 2 856 977 A (HUGHES ALVIN W) 21 October 1958 (1958-10-21) * column 3, line 42 - line 67; figure 1 * -----	1-4,9-12	
X	US 2 688 448 A (LENZ HUGH F) 7 September 1954 (1954-09-07) * figures 2,5 * -----	1,2,4,6	
X	US 3 230 991 A (JOSEF HERMES) 25 January 1966 (1966-01-25) * figures * -----	1-3,7,8	
X	US 5 330 113 A (POSER KIMBERLEY JOHN [CA] ET AL) 19 July 1994 (1994-07-19)	1-4	
Y	* column 3, line 39 - line 43; figures * -----	9-11	
Y	US 5 505 392 A (TUNNICLIFFE GEORGE [GB] ET AL) 9 April 1996 (1996-04-09) * figures 1,3 * -----	9-11	TECHNICAL FIELDS SEARCHED (IPC) B02C
The present search report has been drawn up for all claims			
Place of search Munich		Date of completion of the search 10 October 2007	Examiner Leitner, Josef
CATEGORY OF CITED DOCUMENTS X : particularly relevant if taken alone Y : particularly relevant if combined with another document of the same category A : technological background O : non-written disclosure P : intermediate document		T : theory or principle underlying the invention E : earlier patent document, but published on, or after the filing date D : document cited in the application L : document cited for other reasons ..... & : member of the same patent family, corresponding document	

1

EPO FORM 1503 03.02 (P04C01)

ANNEX TO THE EUROPEAN SEARCH REPORT  
ON EUROPEAN PATENT APPLICATION NO.

EP 07 10 9553

This annex lists the patent family members relating to the patent documents cited in the above-mentioned European search report. The members are as contained in the European Patent Office EDP file on  
The European Patent Office is in no way liable for these particulars which are merely given for the purpose of information.

10-10-2007

Patent document cited in search report		Publication date	Patent family member(s)	Publication date
US 5544821	A	13-08-1996	NONE	
US 2856977	A	21-10-1958	NONE	
US 2688448	A	07-09-1954	NONE	
US 3230991	A	25-01-1966	CH 403533 A DE 1197347 B FR 1345239 A GB 948727 A NL 285908 A	30-11-1965 22-07-1965 06-12-1963 05-02-1964
US 5330113	A	19-07-1994	CA 2115321 A1 DE 4408049 A1 GB 2276569 A JP 2693375 B2 JP 7000846 A	20-09-1994 06-10-1994 05-10-1994 24-12-1997 06-01-1995
US 5505392	A	09-04-1996	NONE	