



(11) **EP 1 990 292 B1**

(12) **EUROPEAN PATENT SPECIFICATION**

(45) Date of publication and mention of the grant of the patent:  
**18.07.2012 Bulletin 2012/29**

(51) Int Cl.:  
**B65D 85/00 (2006.01) A47F 7/00 (2006.01)**  
**B26B 29/00 (2006.01) B65D 73/00 (2006.01)**

(21) Application number: **07714955.7**

(86) International application number:  
**PCT/JP2007/053562**

(22) Date of filing: **27.02.2007**

(87) International publication number:  
**WO 2007/099923 (07.09.2007 Gazette 2007/36)**

(54) **SUPPORT MEMBER FOR EDGED TOOL**

**STÜTZGLIED FÜR EIN MIT EINER SCHNEIDE VERSEHENES WERKZEUG**  
**ELEMENT SUPPORT D'UN OUTIL A BORDS**

(84) Designated Contracting States:  
**DE FR GB**

(72) Inventor: **HASEGAWA, Katsumi**  
**Seki-shi, Gifu 501-3992 (JP)**

(30) Priority: **28.02.2006 JP 2006053244**

(74) Representative: **Novagraaf Technologies**  
**122 rue Edouard Vaillant**  
**92593 Levallois-Perret Cedex (FR)**

(43) Date of publication of application:  
**12.11.2008 Bulletin 2008/46**

(73) Proprietor: **Kai R & D Center Co., Ltd.**  
**Seki-shi, Gifu 501-3992 (JP)**

(56) References cited:  
**JP-A- 2005 187 004 JP-U- 06 085 269**  
**JP-U- 49 088 363 JP-U- 52 114 984**  
**US-A- 5 291 996 US-A1- 2003 159 293**

**EP 1 990 292 B1**

Note: Within nine months of the publication of the mention of the grant of the European patent in the European Patent Bulletin, any person may give notice to the European Patent Office of opposition to that patent, in accordance with the Implementing Regulations. Notice of opposition shall not be deemed to have been filed until the opposition fee has been paid. (Art. 99(1) European Patent Convention).

## Description

### TECHNICAL FIELD

**[0001]** The present invention relates to a support member used in exhibiting edged tools such as scissors.

### BACKGROUND ART

**[0002]** Patent Document 1 discloses a technology in which a bridge part, a retaining cord, or a retaining sheet is used to support western scissors on a mounting sheet, in such a manner that the scissors can be opened and closed. In this instance, the cutting edges of the scissors on the mounting sheet may be touched inadvertently.

**[0003]** In order to solve the above problem, as shown in the third embodiment and the fourth embodiment respectively shown in Figs. 7 to 9 and in Figs. 10 and 11 of Patent Document 2, there is disclosed a technology in which an insertion opening is disposed between both lower end edges of a mounting sheet and a covering sheet superimposed on each other, the cutting edges of western scissors are inserted from the insertion opening and accommodated in a support body formed by the mounting sheet and the covering sheet.

**[0004]** However, in the case of the technology disclosed in Patent Document 2, the handles of western scissors are inadvertently swung, by which the mounting sheet and the covering sheet may be pushed away from each other at a part facing the handles and easily separated. It is thus necessary to use a binding band to reliably position the western scissors with respect to the mounting sheet and the covering sheet.

JP 49088363 discloses a support member according to the preamble of claim 1.

Patent Document 1: Japanese Laid-Open Utility Model Publication No. 5-35743

Patent Document 2: Japanese Laid-Open Patent Publication No. 2005-187004

### DISCLOSURE OF THE INVENTION

**[0005]** An objective of the present invention is to provide a support member for exhibiting an edged tool which is capable of preventing sheets constituting a support body from being separated from each other.

**[0006]** In order to attain the above objective, in the present invention, there is provided a support member used in exhibiting an edged tool having a cutting edge and a handle. The support member is provided with a support body and retaining means. The support body is formed by a first sheet and a second sheet being superimposed on each other so as to form an accommodation chamber between the first sheet and the second sheet. The second sheet is provided inside of the outer peripheral edges with an opening which allows the cutting edge of the edged tool to be inserted. The cutting edge of the edged tool which has been inserted into the opening is

accommodated in the accommodation chamber so as to be covered with the first sheet and the second sheet. The handle of the edged tool of which the cutting edge has been accommodated in the accommodation chamber is arranged so as to be superimposed on the second sheet. The retaining means supports on the support body the edged tool, the cutting edge of which has been accommodated in the accommodation chamber. According to this configuration, since the second sheet is pressed against the first sheet by the handle of the edged tool, the cutting edge of which has been accommodated in the accommodation chamber, it is possible to prevent the second sheet from being separated from the first sheet.

**[0007]** It is preferable that the support body is formed by coupling the separately formed first and second sheets to each other by coupling means. In this instance, the first sheet and the second sheet can be formed of different materials.

**[0008]** It is preferable that the coupling means includes a pair of first coupling portions and a pair of second coupling portions. When a direction in which the cutting edge of the edged tool is inserted into the opening is referred to as an insertion direction, the first coupling portions are located in front in the insertion direction from the second coupling portions. The first coupling portions are arranged on both sides of the cutting edge which has been inserted into the opening. Each of the first coupling portions includes a cut disposed on one of the first sheet and the second sheet and a tongue disposed on the other of the first sheet and the second sheet and inserted into the cut. Each of the cuts and each of the tongues are respectively provided with a locking portion. In a state in which the first sheet and the second sheet are coupled to each other by the second coupling portions, the first sheet or the second sheet is deformed so that the tongues are inserted into the cuts, and thereafter, with the tongues inserted into the cuts, the locking portions of the tongues are locked at the locking portions of the cuts, thereby preventing the tongues from being removed from the cuts.

**[0009]** Alternatively, an interval between the locking portions of the cuts is made smaller than an interval between the locking portions of the tongues, by which the first sheet or the second sheet is deflected and deformed between the first coupling portions so that the accommodation chamber is formed between the first sheet and the second sheet.

**[0010]** It is preferable that the second coupling portions are disposed between the opening and the handle of the edged tool and also closer to the opening than to the handle. In this instance, the second sheet is prevented more reliably from being separated from the first sheet.

**[0011]** It is preferable that the cutting edge of the edged tool accommodated in the accommodation chamber is visible from outside of the first sheet through the first sheet or from outside of the second sheet through the second sheet.

**[0012]** The edged tool is preferably a pair of scissors.

**[0013]** It is preferable that the retaining means includes an inner peripheral edge of the opening, and the inner peripheral edge acts so as to lock the opening/closing pivot of scissors. In this instance, the opening/closing pivot of the scissors can be used to support the scissors on the support body.

**[0014]** It is preferable that the retaining means includes a retaining hole disposed on the first sheet for locking the opening/closing pivot of scissors. In this instance as well, the opening/closing pivot of the scissors can be used to support the scissors on the support body.

**[0015]** It is preferable that the retaining means includes a binding band for bonding the handle of scissors to the support body. In this instance, the binding band can be used to support the scissors on the support body more reliably.

#### BRIEF DESCRIPTION OF THE DRAWINGS

##### **[0016]**

Fig. 1(a) is a front elevational view showing a mounting sheet of a support member for exhibiting an edged tool according to a first embodiment of the present invention;

Fig. 1(b) is a front elevational view showing a covering sheet of the support member;

Fig. 1(c) is a front elevational view showing western scissors to be supported on the support member;

Figs. 2(a), 2(b) and 2(c) are respectively a front elevational view, a rear view, and a side elevational view showing a halfway state in which the support member formed by the mounting sheet shown in Fig. 1(a) and the covering sheet shown in Fig. 1(b) is being made to support the western scissors shown in Fig. 1(c);

Figs. 3(a), 3(b) and 3(c) are respectively a front elevational view, a rear view, and a side elevational view showing a state in which the support member formed by the mounting sheet shown in Fig. 1(a) and the covering sheet shown in Fig. 1(b) is made to support the western scissors shown in Fig. 1(c);

Fig. 4(a) is a front elevational view showing a mounting sheet of a support member for exhibiting an edged tool according to a second embodiment of the present invention;

Fig. 4(b) is a front elevational view showing a covering sheet of the support member;

Fig. 4(c) is a front elevational view showing western scissors to be supported on the support member; and

Figs. 5(a), 5(b) and 5(c) are respectively a front elevational view, a rear view, and a side elevational view showing a state in which the support member formed by the mounting sheet shown in Fig. 4(a) and the covering sheet shown in Fig. 4(b) is made to support the western scissors shown in Fig. 4(c).

#### BEST MODE FOR CARRYING OUT THE INVENTION

**[0017]** First, a description will be given of a support member for exhibiting an edged tool according to a first embodiment of the present invention by referring to Figs. 1(a) to 3(c).

**[0018]** A mounting sheet 1 as a first sheet shown in Fig. 1(a) is formed of an opaque cardboard in a shape longer in the vertical direction Z (the up and down direction in Figs. 1(a) and 1(b)). The mounting sheet 1 is composed of a front face 2 and a back face 3 (refer to Fig. 2(b)) enclosed by the outer peripheral edges including an upper edge 1a, a lower edge 1b, a left edge 1c, and a right edge 1d. In the upper half part of the mounting sheet 1, a suspension hole 4 is formed so as to open both in the front face 2 and the back face 3 at a position that is slightly below the upper edge 1a and in the center in the lateral direction Y (the left and right direction shown in Figs. 1(a) and 1(b)). Streak-like first cuts 5, 6 are formed so as to open both in the front face 2 and the back face 3 at positions slightly inside from the left edge 1c and the right edge 1d on both left and right sides below the suspension hole 4. A circular retaining hole 7 is formed so as to open both in the front face 2 and the back face 3 at the center of the lower half part of the mounting sheet 1 in the lateral direction Y. Streak-like second cuts 8, 9 are formed so as to open both in the front face 2 and the back face 3 at positions slightly inside from the left edge 1c and the right edge 1d on both left and right sides slightly below the retaining hole 7. A pair of band holes 10 are formed so as to open both in the front face 2 and the back face 3 below the retaining hole 7 and also between both cuts 8, 9.

**[0019]** As shown in Fig. 1(b), a covering sheet 11 as a second sheet is formed of a transparent plastic plate in a shape longer in the vertical direction Z. The covering sheet 11 is composed of a front face 12 and a back face 13 (refer to Fig. 2(c)) enclosed by the outer peripheral edges including an upper edge 11a, a lower edge 11b, a left edge 11c, and a right edge 11d. First tongues 14, 15 extend respectively from the left edge 11c and the right edge 11d at positions slightly below the upper edge 11a at the upper half part of the covering sheet 11. An opening 16 is formed so as to open both in the front face 12 and the back face 13 at the center of the lower half part of the covering sheet 11 in the lateral direction Y. Second tongues 17, 18 extend respectively from the left edge 11c and the right edge 11d at positions slightly below the opening 16. A pair of band holes 19 are formed so as to open both in the front face 12 and the back face 13 below the opening 16 and also between both the tongues 17, 18.

**[0020]** The mounting sheet 1 and the covering sheet 11, which are formed separately, are superimposed on each other in a state in which the front face 2 of the mounting sheet 1 is made to face the back face 13 of the covering sheet 11 as shown in Figs. 2(a) to 2(c), thereby forming a support body 20. In this instance, the first

tongues 14, 15 of the upper half part of the covering sheet 11 are inserted into the first cuts 5, 6 of the upper half part of the mounting sheet 1 and the second tongues 17, 18 of the lower half part of the covering sheet 11 are inserted into the second cuts 8, 9 of the lower half part of the mounting sheet 1. The first cut 5 and the first tongue 14 as well as the first cut 6 and the first tongue 15 constitute respectively the first coupling portions 21. The second cut 8 and the second tongue 17 as well as the second cut 9 and the second tongue 18 respectively constitute the second coupling portions 22. The first coupling portions 21 and the second coupling portions 22 constitute coupling means (couplers) for coupling the mounting sheet 1 to the covering sheet 11.

**[0021]** Locking portions 8a, 8b are formed respectively at the upper end and the lower end of the second cut 8, and locking portions 9a, 9b are formed respectively at the upper end and the lower end of the second cut 9. Locking portions 17a, 17b are formed respectively at the upper end and the lower end of the second tongue 17, and locking portions 18a, 18b are formed respectively at the upper end and the lower end of the second tongue 18. The locking portions 17a, 17b of the second tongue 17 lock respectively with the locking portions 8a, 8b of the second cut 8, and the locking portions 18a, 18b of the second tongue 18 lock respectively with the locking portions 9a, 9b of the second cut 9, by which the covering sheet 11 is positioned with respect to the mounting sheet 1 so as not to move along the vertical direction Z.

**[0022]** Locking portion 5a, 5b are formed respectively at the upper end and the lower end of the first cut 5, and locking portions 6a, 6b are formed respectively at the upper end and the lower end of the first cut 6. The L-shaped first tongue 14 is provided with a locking arm portion 14a extending upward along the left edge 11c, and the L-shaped first tongue 15 is provided with a locking arm portion 15a extending upward along the right edge 11d. A locking groove portion 14b as a locking portion is disposed between the locking arm portion 14a and the left edge 11c, and a locking groove portion 15b as a locking portion is disposed between the locking arm portion 15a and the right edge 11d. An interval A (refer to Fig. 1(a)) between the locking portion 5a of the first cut 5 and the locking portion 6a of the first cut 6 is smaller than an interval B (refer to Fig. 1(b)) between the locking groove portion 14b of the first tongue 14 and the locking groove portion 15b of the first tongue 15. In a state in which the second coupling portions 22 are used to couple the mounting sheet 1 to the covering sheet 11, the covering sheet 11 is deflected and deformed in the lateral direction Y and the vertical direction Z, thereby the locking arm portions 14a, 15a of the covering sheet 11 are inserted into the cuts 5, 6 on the mounting sheet 1. When the hand is put off the covering sheet 11 in this state, the locking portions 5a, 6a of the cuts 5, 6 are locked into the locking groove portions 14b, 15b of the covering sheet 11, thereby preventing the tongues 14, 15 from being removed from the cuts 5, 6. In this instance, the covering sheet 11

is deflected and deformed between the first coupling portions 21, thereby forming an accommodation chamber 23 between the mounting sheet 1 and the covering sheet 11.

**[0023]** A pair of western scissors 24 as an edged tool shown in Fig. 1(c) are provided with a pair of scissor pieces 25 supported by an opening/closing pivot 26 so as to move rotationally. Each of the scissor pieces 25 is provided with a cutting edge 27 formed at the distal end from the opening/closing pivot 26 and a handle 28 formed at the proximal end from the opening/closing pivot 26. Each of the handles 28 is provided with a grip ring 28a. A contact part actually touched by the fingers in gripping the edged tool with a hand is an inner peripheral part 28b of the grip ring 28a in the case of the western scissors 24. As shown in Fig. 2(c), the opening/closing pivot 26 is provided with a bolt 26a and a nut 26b. The bolt 26a and the nut 26b are projected from the main faces of the scissor pieces 25.

**[0024]** As shown in Figs. 2(a) to 2(c), the cutting edges 27 of the scissors 24 are inserted into the opening 16 from the front face 12 of the covering sheet 11. Then, as shown in Figs. 3(a) to 3(c), the cutting edges 27 are accommodated in the accommodation chamber 23 between the mounting sheet 1 and the covering sheet 11 so as to be covered by the mounting sheet 1 and the covering sheet 11. In this instance, the upper half parts of the handles 28 of the scissors 24 are located on the front face 12 of the covering sheet 11, while the lower half parts of the handles 28, more specifically, parts of the grip rings 28a, are located below the lower edge 1b of the mounting sheet 1. Then, the nut 26b of the opening/closing pivot 26 of the scissors 24 is locked on the retaining hole 7 of the mounting sheet 1, and the bolt 26a of the opening/closing pivot 26 of the scissors 24 is locked on the inner peripheral edge 16a of the opening 16. Further, a binding band 29 is made to pass through the band hole 10 on the mounting sheet 1 and the band hole 19 on the covering sheet 11, and one of the handles 28 of the scissors 24 is bonded to the support body 20 by using the binding band 29. Thereby, the scissors 24 are supported on the support body 20. The retaining hole 7, the inner peripheral edge 16a of the opening 16, and the binding band 29 constitute retaining means (a retainer) for supporting the scissors 24 on the support body 20.

**[0025]** The second coupling portions 22 are located between a plane orthogonal to the vertical direction Z and also passing through the inner peripheral edge 16a of the opening 16 and a plane orthogonal to the vertical direction Z and also passing through the inner peripheral parts 28b of the grip rings 28a of the handles 28 of the scissors 24 in a closed state. In other words, the second coupling portions 22 are located between the opening 16 and the inner peripheral parts 28b (contact parts) of the grip rings 28a. Further, the second coupling portions 22 are located closer to the opening 16 rather than to the inner peripheral parts 28b of the grip rings 28a. Specifically, when a direction in which the cutting edges 27 of

the scissors 24 are inserted into the opening 16 is referred to as an insertion direction ZU, the second coupling portions 22 are located in front in the insertion direction from an intermediate point between the inner peripheral parts 28b of the grip rings 28a and the opening 16.

[0026] Therefore, the support member for supporting the scissors 24 is exhibited, while being suspended by the suspension hole 4. The cutting edges 27 of the thus exhibited scissors 24 are visible through the transparent covering sheet 11. Further, the handles 28 of the scissors 24 can be directly touched to open and close the handles 28.

[0027] Figs. 4(a) to 5(c) show a support member for exhibiting an edged tool according to a second embodiment of the present invention. Figs. 4(a) to 5(c) correspond respectively to Figs. 1(a) to 1(c) and 3(a) to 3(c). The support member for exhibiting an edged tool of the second embodiment is different from that of the first embodiment in the following points.

[0028] The retaining hole 7 on the mounting sheet 1 is omitted.

[0029] The opening/closing pivot 26 of the scissors 24 is not projected from the main faces of the scissor pieces 25, but is substantially flush with the main faces of the scissor pieces 25.

[0030] A tongue 30b is formed on the opening 16 by a reverse U-shaped cut 30a formed on the covering sheet 11.

[0031] Locking groove portions 18a, 18b are formed at the base part of the right tongue 18 of the tongues 17, 18 on the covering sheet 11. The locking groove portions 18a, 18b are respectively locked by the locking portions 9a, 9b disposed on the right cut 9 of the cuts 8, 9 on the mounting sheet 1, thereby the tongue 18 is prevented from being removed from the cut 9 inadvertently.

[0032] The above-described embodiments may be modified as follows.

[0033] The present invention may also be applicable to a support member used in exhibiting scissors other than western scissors, for example, grip scissors, and edged tools other than scissors, for example, kitchen knives, knives, medical scalpels, razors, nail clippers, and peelers.

[0034] Not only the covering sheet 11 but also the mounting sheet 1 may be formed of transparent plastics.

[0035] In place of coupling the covering sheet 11 to the mounting sheet 1 by using the second coupling portions 22, the lower edge of the covering sheet 11 may be adhered to the lower edge of the mounting sheet 1.

[0036] In place of coupling the separately formed mounting sheet 1 to the separately formed covering sheet 11, a sheet may be folded to form integrally the mounting sheet and the covering sheet. The lower edge of the mounting sheet may be joined to the lower edge of the covering sheet. Also, the left edge of the mounting sheet may be joined to the left edge of the covering sheet. Further, the right edge of the mounting sheet may be joined to the right edge of the covering sheet.

[0037] It is not always necessary to cover the entire cutting edges 27 of the scissors 24 by the mounting sheet 1 and the covering sheet 11. It is, however, preferable that at least the distal ends of the cutting edges 27 are covered by them.

[0038] The interval A between the locking portion 5a of the first cut 5 and the locking portion 6a of the first cut 6 may be made larger than the interval B between the locking groove portion 14b of the first tongue 14 and locking groove portion 15b of the first tongue 15, by which the mounting sheet 1 is deflected and deformed between the first coupling portions 21 so that the accommodation chamber 23 is formed between the mounting sheet 1 and the covering sheet 11.

[0039] In a state in which the cutting edges 27 of the scissors 24 are accommodated in the accommodation chamber, the entire handles 28 may be located above the front face 12 of the covering sheet 11.

[0040] For example, depending on the shape or dimension of the scissors 24, the mounting sheet 1 and the covering sheet 11 may be changed in material, shape, or dimension, whenever necessary.

[0041] Product information may be printed on the mounting sheet 1 and the covering sheet 11.

## Claims

1. A support member used in exhibiting an edged tool (24) having a cutting edge (27) and a handle (28), the support member comprising a support body (20) formed by a first sheet (1) and a second sheet (11) being superimposed on each other so that an accommodation chamber (23) is formed between the first sheet and the second sheet, wherein the second sheet is provided, inside of outer peripheral edges (11a, 11b, 11c, 11d), with an opening (16) which allows the cutting edge of the edged tool to be inserted, the cutting edge of the edged tool inserted into the opening is accommodated in the accommodation chamber so as to be covered by the first sheet and the second sheet, the handle of the edged tool of which the cutting edge has been accommodated in the accommodation chamber is arranged so as to be superimposed on the second sheet, the support member being **characterized in that** it comprises retaining means (7, 16a, 29) for supporting, on the support body, the edged tool, the cutting edge of which has been accommodated in the accommodation chamber, and **in that** the support body is formed by coupling the separately formed first and second sheets to each other by coupling means (21, 22), said coupling means including a pair of first coupling portions (21) and a pair of second coupling portions (22), wherein, when a direction in which the cutting edge of the edged tool is inserted into the opening is referred to as an insertion direction (ZU), the first cou-

pling portions are located in front in the insertion direction from the second coupling portions, wherein the first coupling portions are arranged on both sides of the cutting edge which is inserted into the opening,

wherein each of the first coupling portions includes a cut (5, 6) disposed on one of the first sheet and the second sheet and a tongue (14, 15) disposed on the other of the first sheet and the second sheet and inserted into the cut, each of the cuts and each of the tongues are respectively provided with a locking portion (5a, 5b, 6a, 6b, 14b, 15b), when each of the tongues is inserted into the corresponding cut, the locking portion (14b, 15b) of the tongue lock into the locking portion (5a, 5b, 6a, 6b) of the cut, thereby preventing the tongue from being removed from the cut, and

wherein an interval (A) between the locking portions of the cuts is made smaller than an interval (B) between the locking portions of the tongues, thereby the first sheet or the second sheet is deflected and deformed between the first coupling portions so that the accommodation chamber is formed between the first sheet and the second sheet.

2. The support member according to claim 1, **characterized in that** the second coupling portions are disposed between the opening and the handle of the edged tool and also disposed closer to the opening than to the handle.
3. The support member according to claim 1 or 2, **characterized in that** the cutting edge of the edged tool accommodated in the accommodation chamber is visible from outside of the first sheet through the first sheet or from outside of the second sheet through the second sheet.
4. The support member according to any one of claims 1 to 3, **characterized in that** the edged tool is a pair of scissors (24).
5. The support member according to claim 4, **characterized in that** the retaining means includes an inner peripheral edge (16a) of the opening, and the inner peripheral edge acts so as to lock the opening/closing pivot (26) of the scissors.
6. The support member according to claim 4 or 5, **characterized in that** the retaining means includes a retaining hole (7) disposed on the first sheet for locking the opening/closing pivot (26) of the scissors.
7. The support member according to any one of claims 4 to 6, **characterized in that** the retaining means includes a binding band (29) for bonding the handles of the scissors to the support body.

## Patentansprüche

1. Halteelement, verwendet für die Ausstellung eines mit einer Schneide versehenen Werkzeugs (24) mit einer Schneidekante (27) und einem Griff (28), wobei das Halteelement einen Haltekörper (20) umfasst, der von einer ersten Schicht (1) und einer zweiten Schicht (11) gebildet ist, die übereinander gelegt sind, so dass eine Aufnahmekammer (23) zwischen der ersten Schicht und der zweiten Schicht gebildet wird, wobei die zweite Schicht innerhalb von äußeren peripheren Kanten (11a, 11b, 11c, 11d) mit einer Öffnung (16) versehen ist, die ermöglicht, dass die Scheidekante des mit einer Schneide versehenen Werkzeugs eingeführt wird, die in die Öffnung eingeführte Scheidekante des mit einer Schneide versehenen Werkzeugs, ist in der Aufnahmekammer aufgenommen ist, um von der ersten Schicht und der zweiten Schicht bedeckt zu sein, der Griff des mit einer Schneide versehenen Werkzeugs, dessen Schneidekante in der Aufnahmekammer aufgenommen wurde, so angeordnet ist, dass er über der zweiten Schicht liegt, wobei das Halteelement **dadurch gekennzeichnet ist, dass** es Rückhaltemittel (7, 16a, 29) zum Halten des mit einer Schneide versehenen Werkzeugs auf dem Haltekörper umfasst, wobei dessen Schneidekante in die Aufnahmekammer aufgenommen wurde, und **dadurch**, dass der Haltekörper durch die Kupplung der getrennt gebildeten ersten und zweiten Schicht aneinander durch Kupplungsmittel (21, 22) gebildet ist, wobei die Kupplungsmittel ein Paar erste Kupplungsabschnitte (21) und ein Paar zweite Kupplungsabschnitte (22) umfassen, wobei, wenn eine Richtung, in der die Schneidekante des mit einer Schneide versehenen Werkzeugs in die Öffnung eingeführt wird, als Einführungsrichtung (ZU) bezeichnet wird, sich die ersten Kupplungsabschnitte auf der vorderen Seite in der Einführungsrichtung von den zweiten Kupplungsabschnitten befinden, wobei die ersten Kupplungsabschnitte auf beiden Seiten der Schneidekante angeordnet sind, die in die Öffnung eingeführt ist, wobei jeder der ersten Kupplungsabschnitte einen Schnitt (5, 6) umfasst, der auf einer der ersten Schicht und der zweiten Schicht angeordnet ist, und eine Zunge (14, 15), die auf der anderen der ersten Schicht und der zweiten Schicht angeordnet ist und in den Schnitt eingeführt ist, wobei jeder der Schnitte und jede der Zungen jeweils mit einem Verschlussabschnitt (5a, 5b, 6a, 6b, 14b, 15b) ausgestattet ist, wenn jede der Zungen in den entsprechenden Schnitt eingeführt ist, der Verschlussabschnitt (14b, 15b) des Zungenverschlusses in dem Verschlussabschnitt (5a, 5b, 6a, 6b) des Schnitts blockiert, wodurch verhindert wird, dass die Zunge aus dem

Schnitt entfernt wird, und wobei ein Intervall (A) zwischen den Verschlussabschnitten der Schnitte kleiner ist als ein Intervall (B) zwischen den Verschlussabschnitten der Zungen, wodurch die erste Schicht oder die zweite Schicht zwischen den ersten Kupplungsabschnitten umgebogen und verformt wird, so dass die Aufnahmekammer zwischen der ersten Schicht und der zweiten Schicht gebildet wird.

2. Halteelement nach Anspruch 1, **dadurch gekennzeichnet, dass** die zweiten Kupplungsabschnitte zwischen der Öffnung und dem Griff des mit einer Schneide versehenen Werkzeugs angebracht sind und auch näher an der Öffnung als am Griff angebracht sind.
3. Halteelement nach Anspruch 1 oder 2, **dadurch gekennzeichnet, dass** die Schneidekante des mit einer Schneide versehenen Werkzeugs, die in der Aufnahmekammer aufgenommen ist, von außerhalb der ersten Schicht durch die erste Schicht oder von außerhalb der zweiten Schicht durch die zweite Schicht sichtbar ist.
4. Halteelement nach einem der Ansprüche 1 bis 3, **dadurch gekennzeichnet, dass** das mit einer Schneide versehene Werkzeug eine Schere (24) ist.
5. Halteelement nach Anspruch 4, **dadurch gekennzeichnet, dass** das Rückhaltemittel eine innere periphere Kante (16a) der Öffnung umfasst und die innere periphere Kante derart wirkt, dass sie den Öffnungs-/Verschlussdrehpunkt (26) der Schere blockiert.
6. Halteelement nach Anspruch 4 oder 5, **dadurch gekennzeichnet, dass** das Rückhaltemittel ein Rückhalte Loch (7) umfasst, das auf der ersten Schicht zur Blockierung des Öffnungs-/Verschlussdrehpunkts (26) der Schere angebracht ist.
7. Halteelement nach einem der Ansprüche 4 bis 6, **dadurch gekennzeichnet, dass** das Rückhaltemittel ein Verschlussband (29) zum Binden der Griffe der Schere an den Haltekörper umfasst.

## Revendications

1. Élément de support utilisé pour présenter un outil tranchant (24) comprenant un bord tranchant (27) et une poignée (28), l'élément de support comprenant un corps de support (20) formé par une première feuille (1) et une seconde feuille (11) superposées l'une sur l'autre de sorte qu'une chambre de logement (23) soit formée entre la première feuille et la seconde feuille, dans lequel la seconde feuille est

pourvue, à l'intérieur de bords périphériques extérieurs (11a, 11b, 11c, 11d), d'une ouverture (16) qui permet au bord tranchant de l'outil tranchant d'être inséré, le bord tranchant de l'outil tranchant inséré dans l'ouverture est logé dans la chambre de logement de sorte à être recouvert par la première feuille et la seconde feuille, la poignée de l'outil tranchant dont le bord tranchant a été logé dans la chambre de logement est agencée de sorte à être superposée sur la seconde feuille,

l'élément de support étant **caractérisé en ce qu'il** comprend des moyens de retenue (7, 16a, 29) pour supporter, sur le corps de support, l'outil tranchant, dont le bord tranchant a été logé dans la chambre de logement,

et **en ce que** le corps de support est formé en raccordant les première et seconde feuilles formées séparément l'une avec l'autre par l'intermédiaire de moyens de raccordement (21, 22), lesdits moyens de raccordement comprenant une paire de premières portions de raccordement (21) et une paire de secondes portions de raccordement (22),

dans lequel, lorsqu'une direction dans laquelle le bord tranchant de l'outil tranchant est inséré dans l'ouverture est appelée direction d'insertion (ZU), les premières portions de raccordement sont positionnées à l'avant dans la direction d'insertion à partir des secondes portions de raccordement,

dans lequel les premières portions de raccordement sont agencées sur les deux côtés du bord tranchant qui est inséré dans l'ouverture,

dans lequel chacune des premières portions de raccordement comprend une découpe (5, 6) disposée sur l'une parmi la première feuille et la seconde feuille et une languette (14, 15) disposée sur l'autre feuille et insérée dans la découpe, chacune des découpes et chacune des languettes sont respectivement

pourvues d'une portion de verrouillage (5a, 5b, 6a, 6b, 14b, 15b), lorsque chacune des languettes est insérée dans la découpe correspondante, la portion de verrouillage (14b, 15b) de la languette se verrouille dans la portion de verrouillage (5a, 5b, 6a, 6b) de la découpe, empêchant ainsi la languette d'être retirée de la découpe, et

dans lequel un intervalle (A) entre les portions de verrouillage des découpes est plus petit qu'un intervalle (B) entre les portions de verrouillage des languettes, ainsi la première feuille ou la seconde feuille est défléchie et déformée entre les premières portions de raccordement de sorte que la chambre de logement soit formée entre la première feuille et la seconde feuille.

2. Élément de support selon la revendication 1, **caractérisé en ce que** les secondes portions de raccordement sont disposées entre l'ouverture et la poignée de l'outil tranchant et également disposées plus près de l'ouverture que de la poignée.

3. Élément de support selon la revendication 1 ou 2, **caractérisé en ce que** le bord tranchant de l'outil tranchant logé dans la chambre de logement est visible à partir de l'extérieur de la première feuille à travers la première feuille ou à partir de l'extérieur de la seconde feuille à travers la seconde feuille. 5
4. Élément de support selon une quelconque des revendications 1 à 3, **caractérisé en ce que** l'outil tranchant est une paire de ciseaux (24). 10
5. Élément de support selon la revendication 4, **caractérisé en ce que** les moyens de retenue comprennent un bord périphérique intérieur (16a) de l'ouverture, et le bord périphérique intérieur agit de sorte à verrouiller le pivot d'ouverture/de fermeture (26) des ciseaux. 15
6. Élément de support selon la revendication 4 ou 5, **caractérisé en ce que** les moyens de retenue comprennent un trou de retenue (7) disposé sur la première feuille pour verrouiller le pivot d'ouverture/de fermeture (26) des ciseaux. 20
7. Élément de support selon une quelconque des revendications 4 à 6, **caractérisé en ce que** les moyens de retenue comprennent une bande de liaison (29) pour lier les poignées des ciseaux au corps de support. 25

30

35

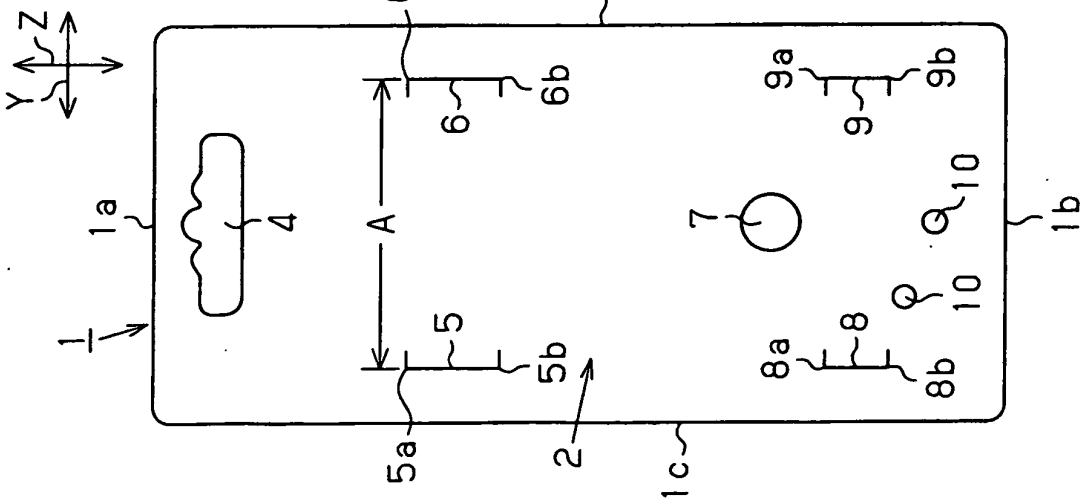
40

45

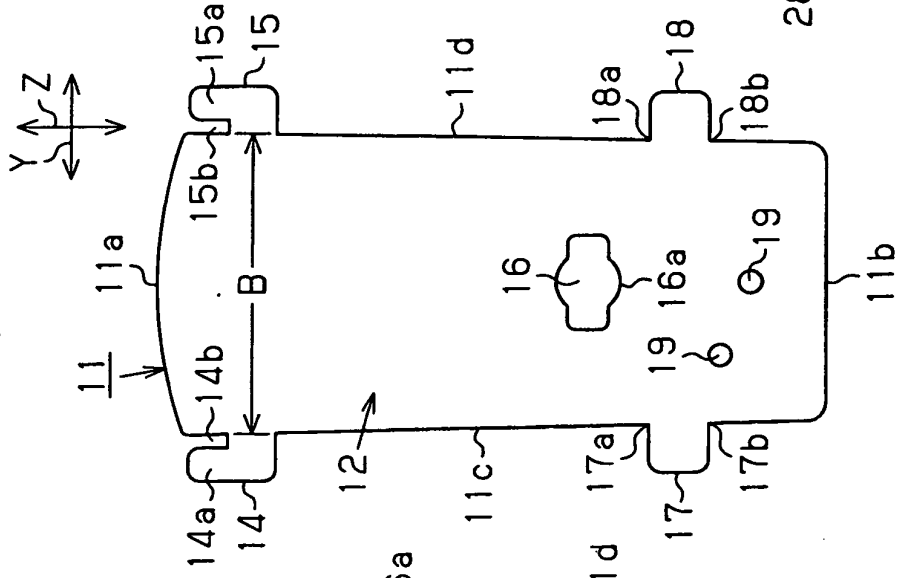
50

55

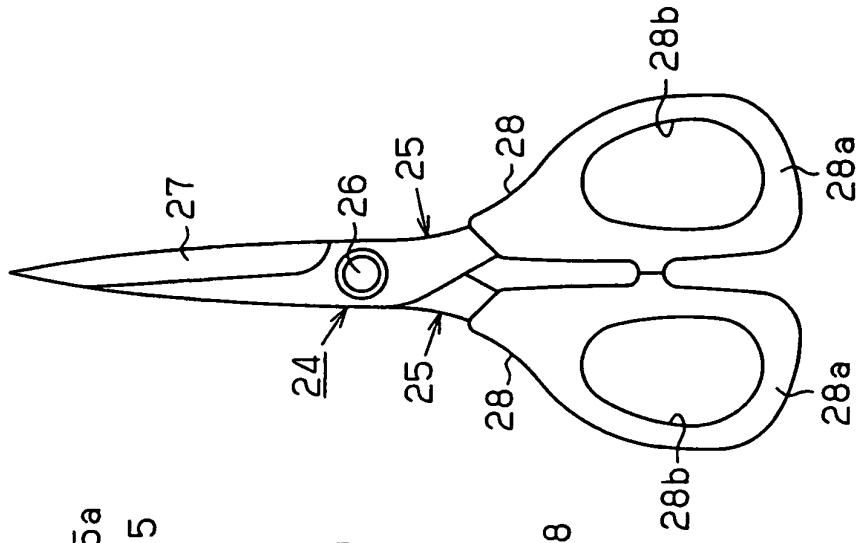
**Fig.1 (a)**



**Fig.1 (b)**



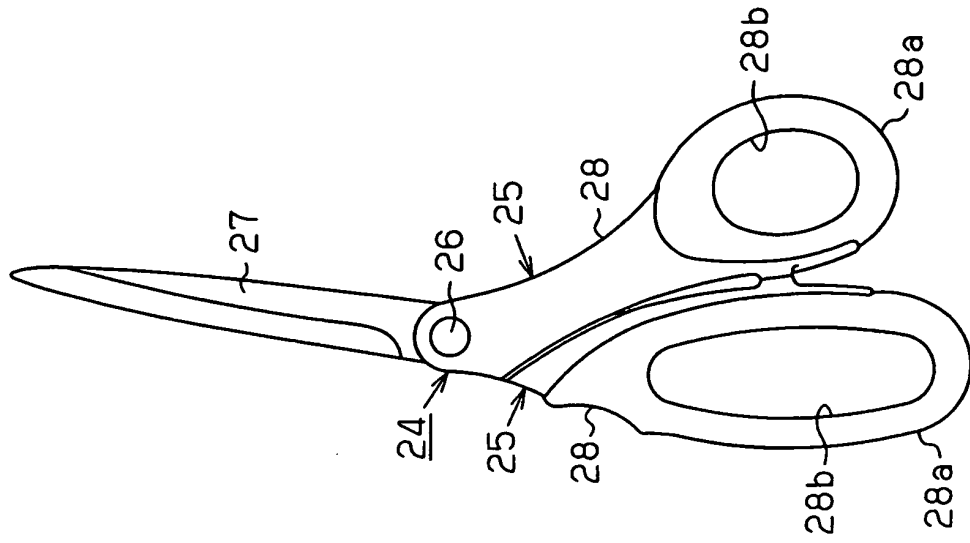
**Fig.1 (c)**



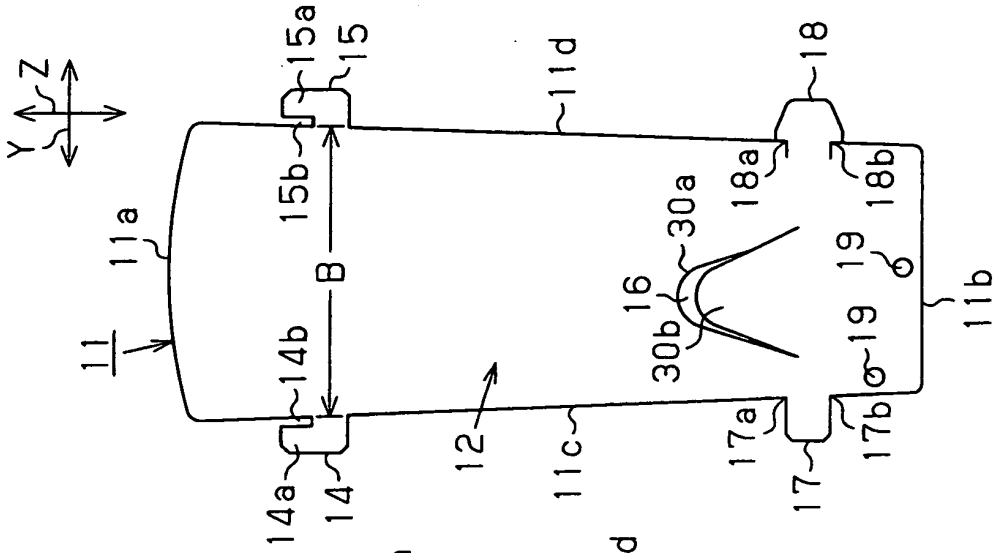




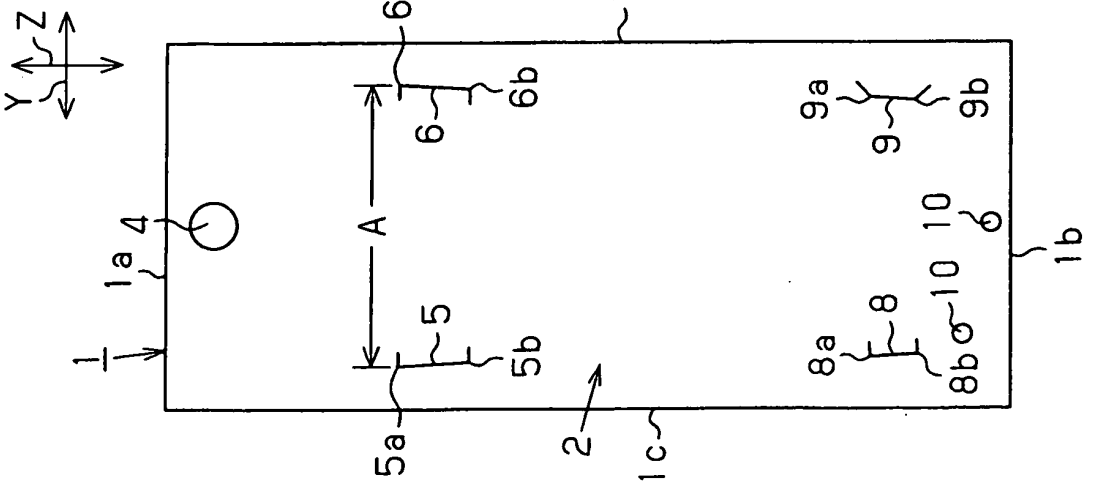
**Fig. 4(c)**



**Fig. 4(b)**



**Fig. 4(a)**





**REFERENCES CITED IN THE DESCRIPTION**

*This list of references cited by the applicant is for the reader's convenience only. It does not form part of the European patent document. Even though great care has been taken in compiling the references, errors or omissions cannot be excluded and the EPO disclaims all liability in this regard.*

**Patent documents cited in the description**

- JP 49088363 B [0004]
- JP 5035743 A [0004]
- JP 2005187004 A [0004]