



Europäisches Patentamt  
European Patent Office  
Office européen des brevets



(11) **EP 0 952 083 B1**

(12) **EUROPEAN PATENT SPECIFICATION**

(45) Date of publication and mention  
of the grant of the patent:  
**27.11.2002 Bulletin 2002/48**

(51) Int Cl.7: **B65B 25/06**

(21) Application number: **98650092.4**

(22) Date of filing: **22.12.1998**

(54) **Method and apparatus for handling food products**

Verfahren und Vorrichtung zum Behandeln von Nahrungsmitteln

Procédé et dispositif pour traiter des produits alimentaires

(84) Designated Contracting States:  
**AT BE CH DE DK ES FI FR GB GR IE IT LI LU MC  
NL PT SE**

(72) Inventor: **Cahill, David  
Dublin 18 (IE)**

(30) Priority: **20.04.1998 IE 980295**

(74) Representative: **O'Brien, John Augustine et al  
John A. O'Brien & Associates,  
Third Floor,  
Duncairn House,  
14 Carysfort Avenue  
Blackrock, Co Dublin (IE)**

(43) Date of publication of application:  
**27.10.1999 Bulletin 1999/43**

(73) Proprietor: **Cahill, David  
Dublin 18 (IE)**

(56) References cited:  
**FR-A- 1 572 357**

**EP 0 952 083 B1**

Note: Within nine months from the publication of the mention of the grant of the European patent, any person may give notice to the European Patent Office of opposition to the European patent granted. Notice of opposition shall be filed in a written reasoned statement. It shall not be deemed to have been filed until the opposition fee has been paid. (Art. 99(1) European Patent Convention).

**Description**Introduction

**[0001]** The invention relates to a method and apparatus for handling food products and in particular for handling white meat, especially chicken products.

**[0002]** In my UK-A-2269083 I have described a method for preparing white meat food products.

**[0003]** With the increasing demands imposed by short lead times there is an ever increasing need to provide methods for handling such food products which allow them to be prepared very efficiently and with the flexibility to maximise throughput with available production resources while facilitating the production of a range of different products.

**[0004]** This invention is directed towards providing an improved handling method and apparatus to address these issues.

Statements of Invention

**[0005]** According to the invention there is provided a method for handling a range of food products comprising the steps of:-

preparing first food products on a first preparation line;

preparing second food products on a second preparation line;

freezing the first food products in a first spiral freezer;

freezing the second food products in a second spiral freezer;

directing the first frozen food products from an upper outlet of the first spiral freezer to a first main conveyor feeding a first packaging station or along a first transfer conveyor to a second packaging station;

directing the second frozen food products from an upper outlet of the second spiral freezer via the second main conveyor either to the second packaging station or along a second transfer conveyor and the first main conveyor to the first packaging station;

turning the first frozen food products on transfer from the first transfer conveyor to direct the transferred food product along a transfer conveyor section extending generally parallel to the second main conveyor; and

adjusting the length of the second main conveyor to deliver frozen food products to one of a number

of different packaging stations.

**[0006]** In a preferred embodiment of the invention the first frozen food products are led, on transfer, downwardly to the second main conveyor.

**[0007]** Preferably the second frozen food products are led, on transfer, upwardly to the first main conveyor.

**[0008]** Ideally, the first or second main conveyor delivers the frozen food products into a chute for delivery to the associated packaging station. Preferably, the chute is of spiral form for delivery of the food products to the associated packaging station.

**[0009]** The invention also provides apparatus for handling a range of food products comprising:

a first preparation line for preparing first food products;

a second preparation line for preparing second food products;

a first spiral freezer for freezing the first food products, the freezer having an upper outlet;

a second spiral freezer for freezing the second food products, the freezer having an upper outlet;

a first main conveyor for delivering frozen food products to a first packaging station;

a second main conveyor for delivering frozen food products to a second packaging station;

a first transfer conveyor for transferring food products from the first spiral freezer outlet to the second packaging station;

a second transfer conveyor for transferring food products from the second main conveyor to the first main conveyor;

first directing means for directing frozen food products from the first spiral freezer to either the first main conveyor or the first transfer conveyor;

second directing means for directing frozen food products from the second spiral freezer to either the second packaging station or to the second transfer conveyor;

the first transfer conveyor having a transfer conveyor section extending generally parallel to the associated main conveyor; and

the second main conveyor being length adjustable to deliver frozen food products to one of a number of different packaging stations.

**[0010]** In a particularly preferred arrangement the apparatus includes a delivery chute having an inlet to which frozen food products are delivered by the first or second main conveyor, the chute having an outlet through which the frozen food products are delivered to the associated packaging station. Preferably, the chute is of spiral form.

#### Brief Description of the Drawings

**[0011]** The invention will be more clearly understood from the following description thereof given by way of example only with reference to the accompanying drawings, in which:-

Fig. 1 is a plan view of an apparatus for handling a range of food products according to the invention;

Fig. 2 is a plan view on an enlarged scale of portion of the apparatus of Fig. 1; and

Fig. 3 is a side, partially perspective view of the apparatus of Fig. 2.

#### Detailed Description

**[0012]** Referring to the drawings, there is illustrated an apparatus for handling a range of food products comprising a first preparation line 1 for preparing fresh food products such as chicken pieces, for example, nuggets, burgers and the like and a second preparation line 2 for preparing second food products such as the same or different food products to those of preparation line 1. Generally, each of the preparation lines 1 and 2 will include deep frying steps. Details of typical preparation lines are given, for example, in my UK-A-2269083. The apparatus includes a first spiral freezer 3 associated with the preparation line 1 and a second spiral freezer 4, associated with the preparation line 2. A first main conveyor 5 delivers frozen food products to a first packaging station 6. Similarly but not shown in the drawings, a second main conveyor 7 is used to deliver frozen food products to a second packaging station 8. A first transfer conveyor 10 is used for transferring food products from the outlet 9 of the first spiral freezer 3 to the second packaging station 8 and a second transfer conveyor 11 is used for transferring food products from the second main conveyor 7 to the first main conveyor 5.

**[0013]** First directing means for directing frozen food products from the first spiral freezer 3 to either the first main conveyor 5 or the first transfer conveyor 10 comprises a take-off chute 20 and a deflecting plate 21 which is pivotally mounted at 22 for movement between a first position illustrated in full lines in Fig 3, in which the food products from the outlet 9 of the first spiral freezer 3 are directed to the first main conveyor 5, to a second position illustrated in dotted outline in Fig 3 in which the food products from the first spiral freezer 3 are directed onto

the first transfer conveyor 10. The first transfer conveyor 10 includes a section 25 extending generally parallel to the associated main second conveyor 7.

**[0014]** To facilitate delivery of food products delivered by the second conveyor 7 into different packing lines, the conveyor 7 is length adjustable from a first extended position (not shown in the drawings) in which the food products from the second spiral freezer 4 are delivered directly by the second conveyor 7 and through a spiral delivery chute 30 onto the packaging line 8. The length of the conveyor 7 is adjustable to a second retracted position illustrated in full lines in Fig 3, in which the food products from the second spiral freezer 4 are delivered onto the second transfer conveyor 11 for delivery onto the first main conveyor 5 to the packaging station 6. In this case the second main conveyor 7 is also adjustable to a third position intermediate the first and second positions in which the food products from the second spiral freezer 4 are delivered along a diverting chute 35 to a further packaging station 36. Thus, the length adjustment of the second main conveyor 7 provides a second directing means for directing freezer food products from the second spiral freezer outlet 14 to one of a number of packaging stations 8 (not shown in the drawings), 36 or to the second transfer conveyor 11.

**[0015]** It will be noted that the outlet line from the first spiral freezer 3 is located above the outlet from the second spiral freezer 4 and consequently the first transfer conveyor 10 is directed downwardly to deliver the first food products from the first spiral freezer 3 to the second main conveyor 7. Similarly, the second transfer conveyor 11 is directed upwardly from the second main conveyor 7 for delivery of the second food products onto the first main conveyor 5 to the packaging station 6.

**[0016]** The handling method and apparatus of the invention for frozen food products achieves considerable flexibility in production efficiency as different, or indeed the same food products may be made independently on the lines 1 and 2 to the maximum production rates of those lines and then frozen in a way that optimises the capacity of both the spiral freezers 3 and 4. To achieve flexibility in packaging the frozen food products from the second spiral freezer 4 may, using the method and apparatus of the invention, be directed to any one of three separate packaging lines depending on requirements. For example, the packaging line 6 may be for catering packs of shaped white meat food products. The packaging line 8 may be for retail packs of similar products, and the packaging line 36 may be used for hand packaging of specialist lines. Thus the method and apparatus provides considerable flexibility and allows production efficiency to be optimised while minimising lead times, and allowing a range of different products to be produced.

**[0017]** Many variations on the specific embodiments of the invention will be readily apparent and accordingly, the invention is not limited to any embodiments hereinbefore described which may be varied in both construc-

tion and detail.

(30) is of spiral form for delivery of the food products to the associated packaging station (8).

### Claims

1. A method for handling a range of food products comprising the steps of:-

preparing first food products on a first preparation line (1);

preparing second food products on a second preparation line (2);

freezing the first food products in a first spiral freezer (3);

freezing the second food products in a second spiral freezer (4);

directing the first frozen food products from an upper outlet (9) of the first spiral freezer (3) to a first main conveyor (5) feeding a first packaging station (6) or along a first transfer conveyor (10) to a second packaging station (8);

directing the second frozen food products from an upper outlet (14) of the second spiral freezer (4) via the second main conveyor (7) either to the second packaging station (8) or along a second transfer conveyor (11) and the first main conveyor (5) to the first packaging station (6);

turning the first frozen food products on transfer from the first transfer conveyor (10) to direct the transferred food product along a transfer conveyor section (25) extending generally parallel to the second main conveyor (7); and

adjusting the length of the second main conveyor (7) to deliver frozen food products to one of a number of different packaging stations (6, 8, 36).

2. A method as claimed in any preceding claim wherein the first frozen food products are led, on transfer, downwardly to the second main conveyor (7).

3. A method as claimed in any preceding claim wherein the second frozen food products are led, on transfer, upwardly to the first main conveyor (5).

4. A method as claimed in any preceding claim wherein the first or second main conveyor (5, 7) delivers the frozen food products into a chute (30, 35) for delivery to the associated packaging station.

5. A method as claimed in claim 4 wherein the chute

6. Apparatus for handling a range of food products comprising:

a first preparation line (1) for preparing first food products;

a second preparation line (2) for preparing second food products;

a first spiral freezer (3) for freezing the first food products, the freezer (3) having an upper outlet (9);

a second spiral freezer (4) for freezing the second food products, the freezer (4) having an upper outlet (14);

a first main conveyor (5) for delivering frozen food products to a first packaging station (6);

a second main conveyor (7) for delivering frozen food products to a second packaging station (8);

a first transfer conveyor (10) for transferring food products from the first spiral freezer outlet (9) to the second packaging station (8);

a second transfer conveyor (11) for transferring food products from the second main conveyor (7) to the first main conveyor (5);

first directing means (20, 21) for directing frozen food products from the first spiral freezer (3) to either the first main conveyor (5) or the first transfer conveyor (10);

second directing means (7) for directing frozen food products from the second spiral freezer (4) to either the second packaging station (8) or to the second transfer conveyor (11);

the first transfer conveyor (10) having a transfer conveyor section (25) extending generally parallel to the associated main conveyor (7); and

the second main conveyor (7) being length adjustable to deliver frozen food products to one of a number of different packaging stations (6, 8, 36).

7. Apparatus as claimed in claim 6 including a delivery chute (30, 35) having an inlet to which frozen food products are delivered by the first or second main conveyor (5, 7), the chute (30, 35) having an outlet

through which the frozen food products are delivered to the associated packaging station (8,36).

8. Apparatus as claimed in claim 7 wherein the chute (30) is of spiral form.

### Patentansprüche

1. Verfahren zur Handhabung einer Palette von Lebensmittelprodukten, das die Schritte umfasst:

Herstellung von ersten Lebensmittelprodukten auf einer ersten Herstellungsstraße (1);

Herstellung von zweiten Lebensmittelprodukten auf einer zweiten Herstellungsstraße (2);

Einfrieren der ersten Lebensmittelprodukte in einem ersten Spiralgefrierapparat (3);

Einfrieren der zweiten Lebensmittelprodukte in einem zweiten Spiralgefrierapparat (4);

Leiten der ersten eingefrorenen Lebensmittelprodukte von einem oberen Auslass (9) des ersten Spiralgefrierapparats (3) zu einer ersten Hauptförderanlage (5), die eine erste Verpackungsstation (6) beliefert, oder entlang einer ersten Übertragungsförderanlage (10) zu einer zweiten Verpackungsstation (8);

Leiten der zweiten eingefrorenen Lebensmittelprodukte von einem oberen Auslass (14) des zweiten Spiralgefrierapparats (4) über die zweite Hauptförderanlage (7), entweder zur zweiten Verpackungsstation (8) oder entlang einer zweiten Übertragungsförderanlage (11) und der ersten Hauptförderanlage (5) zur ersten Verpackungsstation (6);

Lenken der ersten eingefrorenen Lebensmittelprodukte auf dem Übertragungsweg von der ersten Übertragungsförderanlage (10), so dass das übertragene Lebensmittelprodukt entlang eines Übertragungsförderanlagenabschnitts (25) geleitet wird, der sich im Allgemeinen parallel zur zweiten Hauptförderanlage (7) erstreckt; und

Einstellen der Länge der zweiten Hauptförderanlage (7), so dass eingefrorene Lebensmittelprodukte einer von einer Anzahl von verschiedenen Verpackungsstationen (6, 8, 36) zugeführt werden.

2. Verfahren nach einem der vorhergehenden Ansprüche, wobei die ersten eingefrorenen Lebensmittel-

produkte auf dem Übertragungsweg abwärts zur zweiten Hauptförderanlage (7) geleitet werden.

3. Verfahren nach einem der vorhergehenden Ansprüche, wobei die zweiten eingefrorenen Lebensmittelprodukte auf dem Übertragungsweg aufwärts zur ersten Hauptförderanlage (5) geleitet werden.

4. Verfahren nach einem der vorhergehenden Ansprüche, wobei die erste oder zweite Hauptförderanlage (5,7) die eingefrorenen Lebensmittelprodukte zwecks Zuführung zur zugehörigen Verpackungsstation einer Rutsche (30, 35) zuführt.

5. Verfahren nach Anspruch 4, wobei die Rutsche (30) für die Zuführung der Lebensmittelprodukte zur zugehörigen Verpackungsstation (8) eine Spiralförmigkeit aufweist.

6. Apparat zur Handhabung einer Palette von Lebensmittelprodukten, der umfasst:

eine erste Herstellungsstraße (1) zur Herstellung erster Lebensmittelprodukte;

eine zweite Herstellungsstraße (2) zur Herstellung zweiter Lebensmittelprodukte;

einen ersten Spiralgefrierapparat (3) zum Einfrieren der ersten Lebensmittelprodukte, wobei der Gefrierapparat (3) einen oberen Auslass (9) aufweist;

einen zweiten Spiralgefrierapparat (4) zum Einfrieren der zweiten Lebensmittelprodukte, wobei der Gefrierapparat (4) einen oberen Auslass (14) aufweist;

eine erste Hauptförderanlage (5) für die Zufuhr von eingefrorenen Lebensmittelprodukten zu einer ersten Verpackungsstation (6);

eine zweite Hauptförderanlage (7) für die Zufuhr von eingefrorenen Lebensmittelprodukten zu einer zweiten Verpackungsstation (8);

eine erste Übertragungsförderanlage (10) für die Übertragung von Lebensmittelprodukten vom ersten Spiralgefrierapparatauslass (9) zur zweiten Verpackungsstation (8);

eine zweite Übertragungsförderanlage (11) für die Übertragung von Lebensmittelprodukten von der zweiten Hauptförderanlage (7) zur ersten Hauptförderanlage (5);

erste Führungsmittel (20, 21) zum Leiten eingefrorener Lebensmittelprodukte vom ersten

Spiralgefrierapparat (3) zu entweder der ersten Hauptförderanlage (5) oder der ersten Übertragungsförderanlage (10);

zweite Führungsmittel (7) zum Leiten eingefrorener Lebensmittelprodukte vom zweiten Spiralgefrierapparat (4) zu entweder der zweiten Verpackungsstation (8) oder der zweiten Übertragungsförderanlage (11);

wobei die erste Übertragungsförderanlage (10) einen Übertragungsförderanlagenabschnitt (25) aufweist, der sich im Allgemeinen parallel zur zugehörigen Hauptförderanlage (7) erstreckt; und wobei die zweite Hauptförderanlage (7) in der Länge einstellbar ist, um eingefrorene Lebensmittelprodukte einer von einer Anzahl von verschiedenen Verpackungsstationen (6, 8, 36) zuzuführen.

7. Apparat nach Anspruch 6, der eine Zufuhrutsche (30, 35) umfasst, die einen Einlass aufweist, in den eingefrorene Lebensmittelprodukte über die erste oder die zweite Hauptförderanlage (5, 7) eingeführt werden, wobei die Rutsche (30, 35) einen Auslass aufweist, durch den die eingefrorenen Lebensmittelprodukte der zugehörigen Verpackungsstation (8, 36) zugeführt werden.

8. Apparat nach Anspruch 7, wobei die Rutsche (30) eine Spiralform aufweist.

### Revendications

1. Procédé permettant de manipuler une gamme de produits alimentaires, comprenant les étapes suivantes :

préparation de premiers produits alimentaires sur une première chaîne de préparation (1) ;

préparation de deuxièmes produits alimentaires sur une deuxième chaîne de préparation (2) ;

congélation des premiers produits alimentaires dans un premier congélateur en spirale (3) ;

congélation des deuxièmes produits alimentaires dans un deuxième congélateur en spirale (4) ;

acheminement des premiers produits alimentaires congelés depuis une sortie supérieure (9) du premier congélateur en spirale (3) en direction d'un premier convoyeur principal (5) qui alimente un premier poste de conditionnement (6) ou bien le long d'un premier convoyeur de

transfert (10) en direction d'un deuxième poste de conditionnement (8) :

acheminement des deuxièmes produits alimentaires congelés depuis une sortie supérieure (14) du deuxième congélateur en spirale (4), par l'interrédiaire du deuxième convoyeur principal (7), soit en direction du deuxième poste de conditionnement (8), soit le long d'un deuxième convoyeur de transfert (11) et du premier convoyeur principal (5) en direction du premier poste de conditionnement (6) ;

pivotement des premiers produits alimentaires congelés en cours de transfert depuis le premier convoyeur de transfert (10) afin de diriger les produits alimentaires transférés le long d'une section convoyeur de transfert (25) qui s'étend dans un sens généralement parallèle au deuxième convoyeur principal (7); et

réglage de la longueur du deuxième convoyeur principal (7) pour permettre aux produits alimentaires congelés d'être livrés à l'un d'un certain nombre de différents postes de conditionnement (6, 8, 36).

2. Procédé, selon l'une quelconque des revendications précédentes, dans lequel les premiers produits alimentaires congelés sont amenés, en cours de transfert, vers le bas jusqu'au deuxième convoyeur principal (7).

3. Procédé, selon l'une quelconque des revendications précédentes, dans lequel les deuxièmes produits alimentaires congelés sont amenés, en cours de transfert, vers le haut jusqu'au premier convoyeur principal (5).

4. Procédé, selon l'une quelconque des revendications précédentes, dans lequel le premier ou le deuxième convoyeur principal (5,7) amène les produits alimentaires congelés dans une goulotte (30, 35) en vue d'un acheminement au poste de conditionnement associé.

5. Procédé, selon la revendication 4, dans lequel la goulotte (30) a une forme en spirale, afin d'acheminer les produits alimentaires au poste de conditionnement associé (8).

6. Appareil permettant de manipuler une gamme de produits alimentaires, comprenant les éléments suivants :

une première chaîne de préparation (1) destinée à la préparation de premiers produits alimentaires ;

une deuxième chaîne de préparation (2) destinée à la préparation de deuxièmes produits alimentaires ;

un premier congélateur en spirale (3) destiné à congeler les premiers produits alimentaires, le congélateur (3) possédant une sortie supérieure (9) ;

un deuxième congélateur en spirale (4) destiné à congeler les deuxièmes produits alimentaires, le congélateur (4) possédant une sortie supérieure (14) ;

un premier convoyeur principal (5) destiné à amener des produits alimentaires congelés vers un premier poste de conditionnement (6) ;

un deuxième convoyeur principal (7) destiné à amener des produits alimentaires congelés vers un deuxième poste de conditionnement (8) ;

un premier convoyeur de transfert (10) destiné à transférer des produits alimentaires depuis la sortie (9) du premier congélateur en spirale jusqu'au deuxième poste de conditionnement (8) ;

un deuxième convoyeur de transfert (11) destiné à transférer des produits alimentaires depuis le deuxième convoyeur principal (7) jusqu'au premier convoyeur principal (5) ;

un premier moyen directeur (20, 21) destiné à diriger les produits alimentaires congelés depuis le premier congélateur en spirale (3), soit vers le premier convoyeur principal (5), soit vers le premier convoyeur de transfert (10) ;

un deuxième moyen directeur (7) destiné à diriger les produits alimentaires congelés depuis le deuxième congélateur en spirale (4), soit vers le deuxième poste de conditionnement (8), soit vers le deuxième convoyeur de transfert (11) ;

le premier convoyeur de transfert (10) possédant une section convoyeur de transfert (25) qui s'étend dans un sens généralement parallèle au convoyeur principal associé (7) ; et

le deuxième convoyeur principal (7), ayant une longueur réglable, pour permettre aux produits alimentaires congelés d'être livrés à l'un d'un certain nombre de différents postes de conditionnement (6, 8, 36).

goulotte de livraison (30, 35) possédant une entrée, au niveau de laquelle le premier ou le deuxième convoyeur principal (5, 7) acheminent les produits alimentaires congelés, la goulotte (30, 35) possédant une sortie à travers laquelle les produits alimentaires congelés passent pour être amenés au poste de conditionnement associé (8, 36).

8. Appareil, selon la revendication 7, dans lequel la goulotte (30) a une forme en spirale.

7. Appareil, selon la revendication 6, comportant une

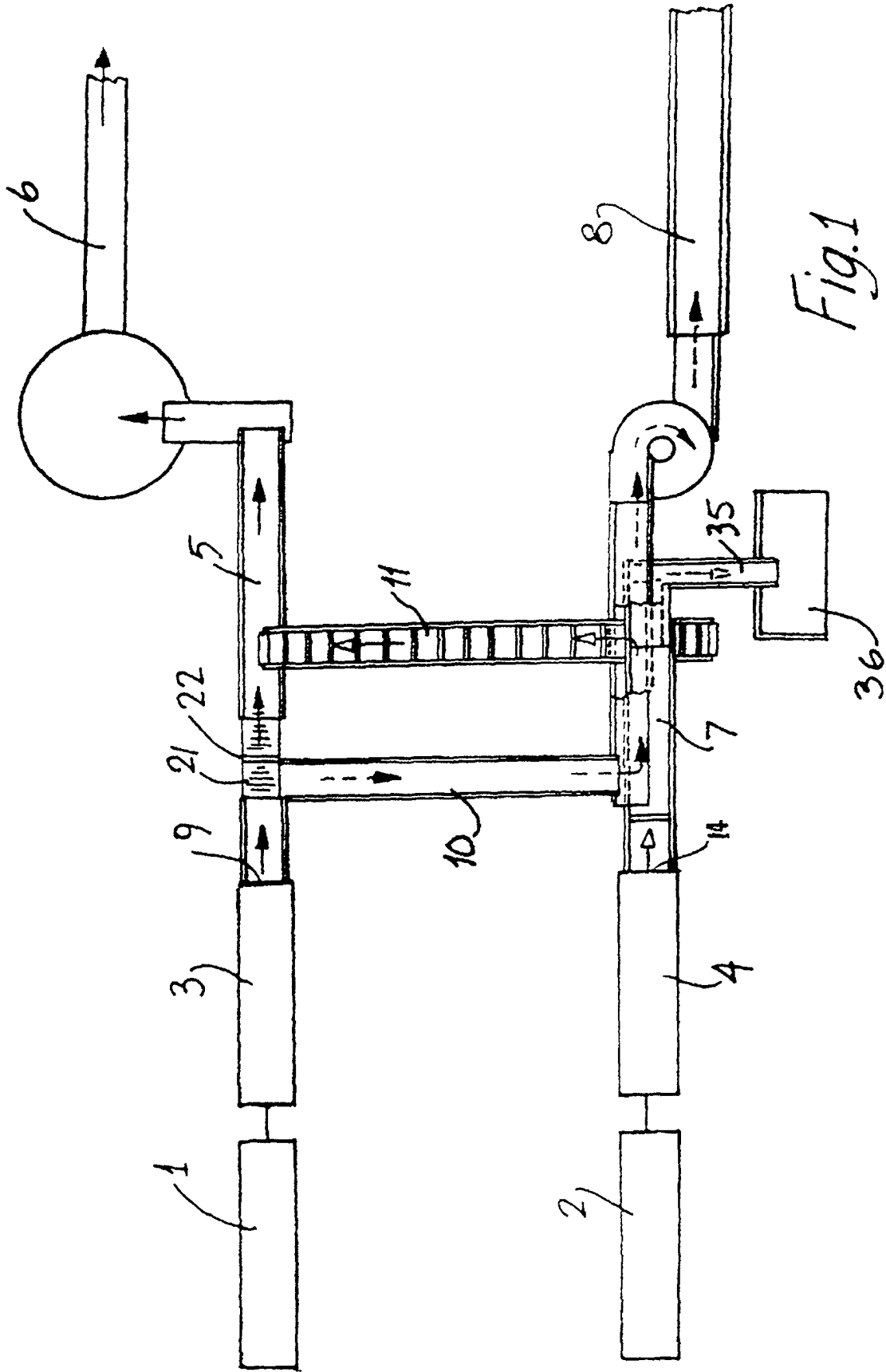

Fig. 1

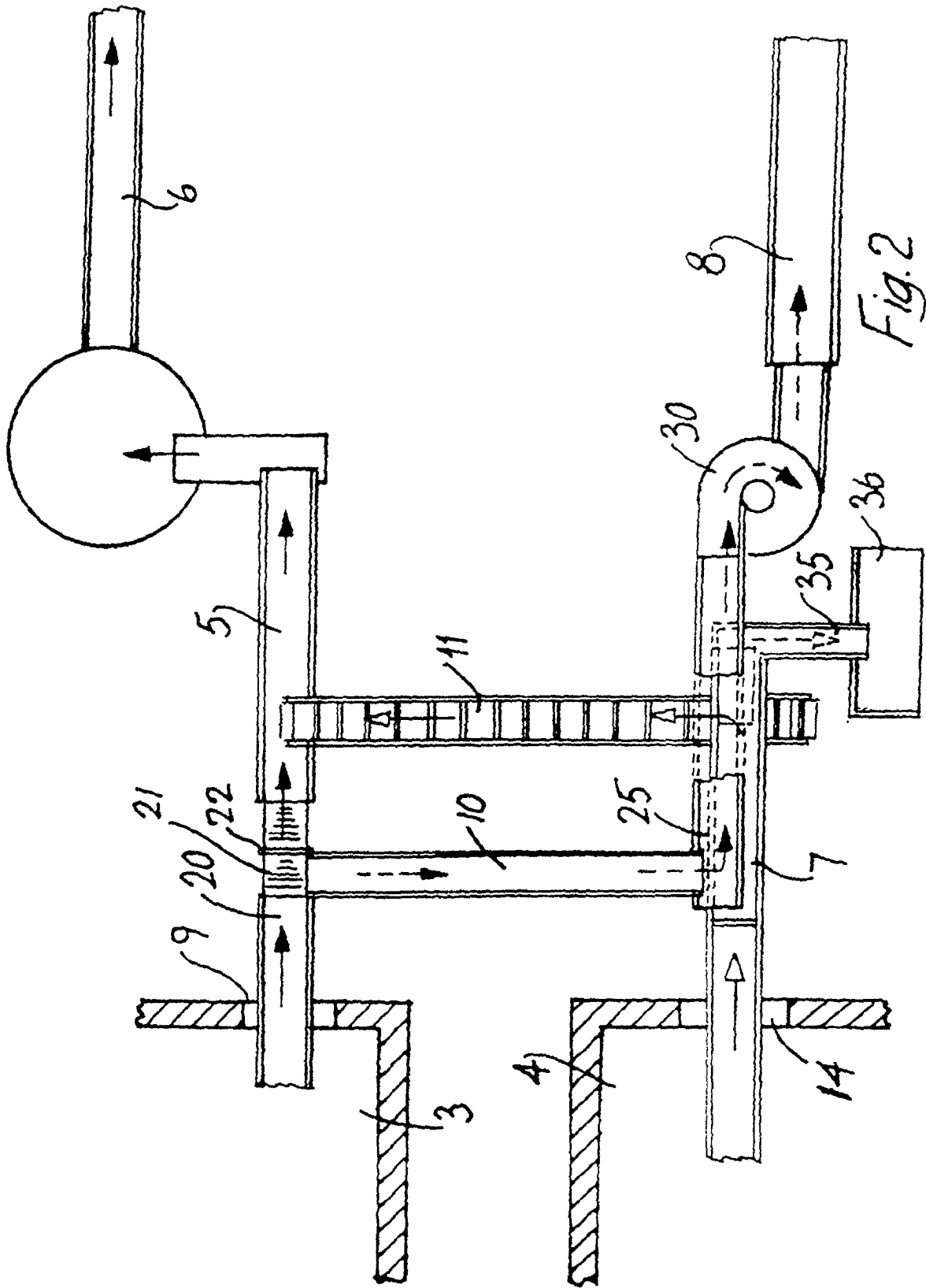

Fig. 2

