

Feb. 9, 1971

G. CACHELIN

3,561,209

WRISTWATCH WRISTLET MOUNTING MEANS

Filed Sept. 30, 1968

3 Sheets-Sheet 1

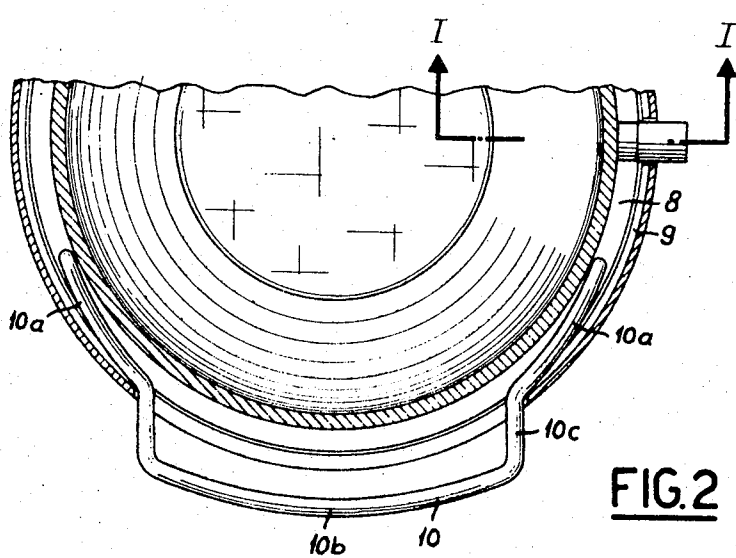
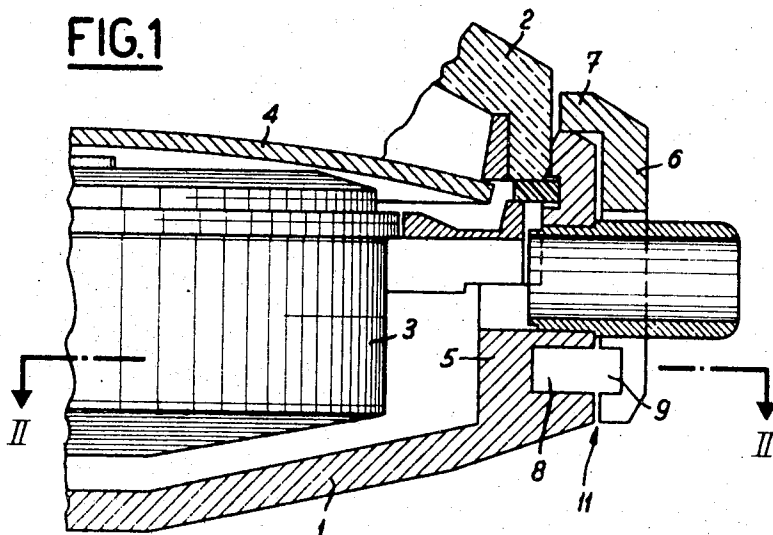

FIG. 2

INVENTOR:

GÉRARD CACHELIN

By *Robert E. Burns*
Attorney

Feb. 9, 1971

G. CACHELIN

3,561,209

WRISTWATCH WRISTLET MOUNTING MEANS

Filed Sept. 30, 1968

3 Sheets-Sheet 2

FIG. 3

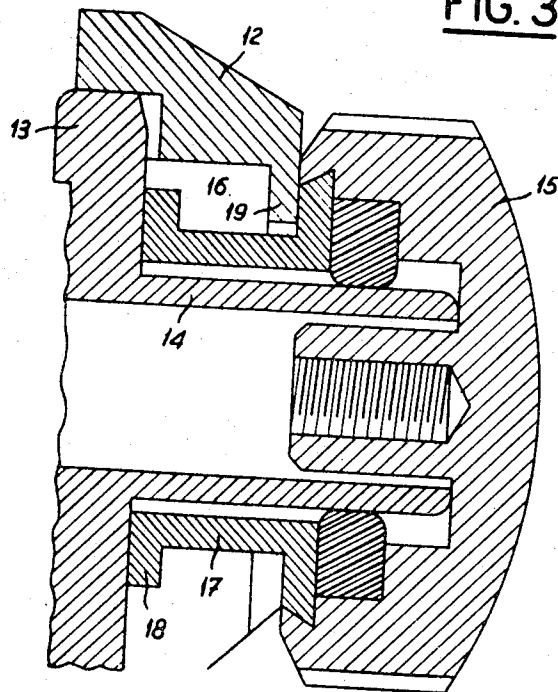

INVENTOR:

GÉRARD CACHELIN

By *Robert E. Burns*
Attorney

Feb. 9, 1971

G. CACHELIN

3,561,209

WRISTWATCH WRISTLET MOUNTING MEANS

Filed Sept. 30, 1968

3 Sheets-Sheet 3

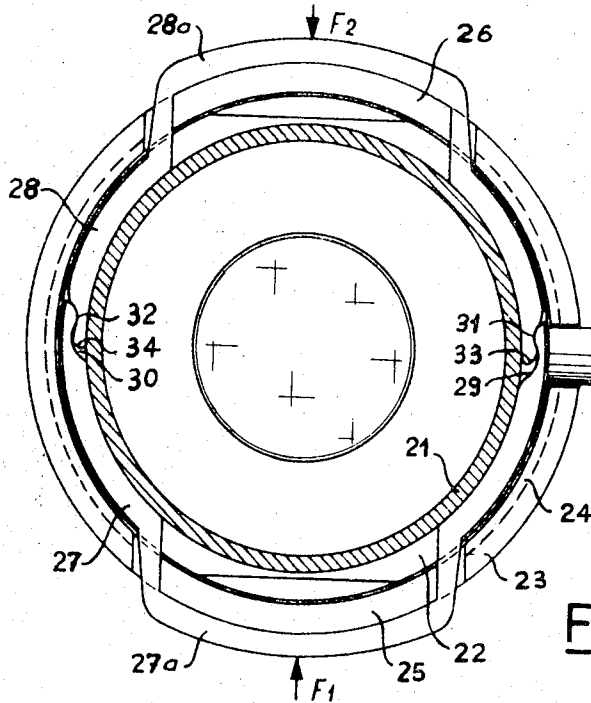

FIG. 4

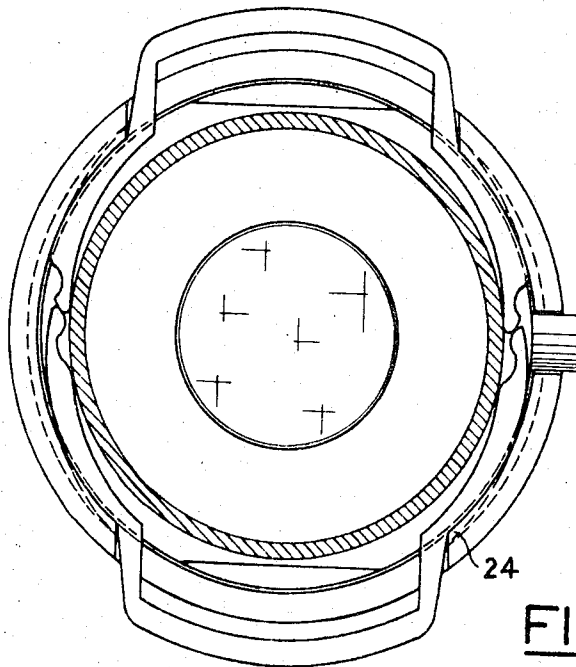

FIG. 5

INVENTOR:

GÉRARD CACHELIN

By *Robert E. Burns*
Attorney

1

2

3,561,209

WRISTWATCH WRISTLET MOUNTING MEANS
 Gérard Cachelin, Le Locle, Switzerland, assignor to
 Fabrique d'Horlogerie Ch. Tissot & Fils S.A., Le Locle,
 Switzerland, a Swiss company

Filed Sept. 30, 1968, Ser. No. 763,813

Claims priority, application Switzerland, Oct. 4, 1967,
 13,854/67; Mar. 28, 1968, 4,630/68

Int. Cl. G04b 37/00

U.S. Cl. 58—88

4 Claims

ABSTRACT OF THE DISCLOSURE

A wristwatch case having a side wall on which is engaged a removable outer ring, the adjacent faces of these members each having a groove in which fit the ends of two spring elements serving to axially maintain the outer ring on the side wall, the middle part of these elements forming lugs or loops for fixing the wristlet.

The present invention has for its object a wristwatch, the case of which has a side wall on which is engaged a removable outer ring.

It has already been proposed to make wristwatches with interchangeable middle-bezels, in which the said middle-bezel bears axially on the outside of the case under the pulling effect of a wristlet made of one piece and passing under the watch through loops or lugs integral with the removable middle bezel. In addition to the fact that a breaking of the wristlet can result in loss of the watch, such an approach is not possible when the wristlet is made of two parts, the wristwatch being able to become free from the removable middle bezel each time the wearer of the watch takes it off.

The present invention precisely has for its object a wristwatch with a removable outer ring or bezel in which the wristlet does not participate in the retention of the ring on the side wall.

The wristwatch according to the invention is characterized by the fact that the facing surfaces of the side wall and ring each have a groove in which fit the extremities of two spring wires so as to axially retain the outer ring on the side wall, the middle part of these springs forming loops or lugs for securing the wristlet.

The accompanying drawing represents by way of example two embodiments of the present invention.

FIG. 1 shows a first embodiment seen in cross section taken along line I-I of FIG. 2.

FIG. 2 shows a plane view and cross section taken along line II-II of FIG. 1.

FIG. 3 shows a modification of the winding stem.

FIG. 4 shows an underneath plan view partially in cross section of a second embodiment.

FIG. 5 shows this second embodiment with springs unhooked.

According to the first embodiment a single shell case 1 is closed by a crystal 2, and has a movement 3 disposed therein and surmounted by a dial 4.

The single shell case 1 includes the back of the watch, and a side wall 5 extending from the periphery of the back. An outer ring 6 fits axially over the side wall 5, and is provided with a bezel 7 which bears axially on a portion of the side wall 5.

Both the side wall 5 and the ring 6 are provided with grooves 8, 9, respectively, which makes it possible to axially unite the case and ring by means of two spring wires 10 the extremities of which 10a simultaneously engage in the two grooves 8 and 9. That is, the grooves 8 and 9 are in face to face alignment, and both members 5 and 6 have openings therein for receiving the wire

ends 10a. The middle parts 10b of these springs form two loops for securing the wristlet.

The extremities 10a of the springs have a curvature which is identical to that of groove 8 but the centre of which does not coincide with that of the groove so that they pinch the side wall 5, within the groove 8, in such a way that the elastic deformation of these springs which are tends to radially expel the springs retained by the ring 6. These springs therefore bear simultaneously on the outward face of the groove 8 in the side wall 5 and the inner face of the groove 9 in the ring 6, thereby maintaining same together without intervention on the part of wristlet.

A slight radial play 11 is additionally left between the member 5 and 6, on the one hand to facilitate the introduction of the ring on the side wall and on the other hand so that impacts received by the ring are not transmitted directly to the shell 1 but are transmitted by springs 10 which thus behave like shock absorbers.

The placing and the removal of the ring 6 takes place easily by grasping the watch between two fingers to press the two springs one against the other. By means of this pressure, parts 10a of the springs become disengaged from the walls of groove 9 while allowing free passage to the ring axially away from the side wall 5.

It is readily possible to hide the radial parts 10c of the springs by simulated horns which extend above these parts or by a specially shaped bezel.

FIG. 3 shows as a modification how it is possible to take advantage of the presence of the removable ring 6 to form a stop during movement of the winding stem. Such a stop is in effect desirable in a single shell case when the stem is pulled to set, since an excessive pulling force may result in the stem being pulled out completely. To provide such a stop, an outer removable ring 12 mounted on a shell side wall 13 and extends into a tube 14 on which slides a winding button 15. The ring 12 has space 16 near the tube in which slides a tubular sleeve 17 set in the button 15 and having a heel 18 which, when the button 15 is pulled, meets wall 19 of ring 12. This construction naturally is only possible with an outer ring of the type described, and having a U-shape which makes it possible to introduce it on the tube.

Many modifications are possible, and the invention is particularly effective when the outer ring encloses the lower edge of the crystal, whereby the removable ring hides the side wall.

In the second embodiment represented in FIGS. 4 and 5, the shell side wall 21 has a circular groove 22 and can form part of a single shell case, and outer ring 23, which is removable, has a circular groove 24 and two spaces 25 and 26 allow the passage of loops 27a and 28a formed by two springs 27 and 28. The extremities of these springs have curved surfaces 29 and 30, 31 and 32 respectively, by means of which the springs were hooked to one another. In this hooked position the springs are applied against the bottom of grooves 22 and completely free the outer ring 23. The springs hook automatically one to the other when pressure is exerted on loops 27a and 28a in the direction of arrows F1 and F2 by grasping for example the watch between two fingers. The engagement of the springs is facilitated by two inclined planes 33 and 34 at the extremities of one of the springs.

The springs being hooked to one another it is easy to dispose, remove or exchange the outer ring without risk of either loosening the spring or of letting fall either the outer ring or the case as a result of a false movement. The outer ring being in place it suffices to exert a slight pull on the loops to unhook the springs which then will occupy the position shown in FIG. 5 and engage to groove

3

24 in the outer ring thereby locking the latter. This locking position is maintained on the one hand by the pull of the bracelet and on the other hand by the opposite action of the two springs.

It is naturally possible to provide other hooking systems for the ends of the springs. One of the ends could for example have a head which would engage in a clamp of the other end. Moreover it is clear that the cross section of the springs can be any configuration whatever, but is preferably round or polygonal.

What is claimed is:

1. A wristwatch comprising a case, a side wall for said case, a removable outer ring engaged over said side wall, said side wall and ring having facing grooves, and spring elements having extremities engaging in said grooves in order to axially maintain said ring on said side wall, the middle part of said elements forming loops serving to secure a wristlet, wherein said extremities of said spring elements pinch said side wall, said side wall being curved and said extremities having a curvature substantially identical therewith but closed in such a way that an inward radial pressure exerted on the middle part of said elements will apply the ends of said springs solely within the groove of said side wall, to thereby free said outer ring.

2. A wristwatch according to claim 1, wherein said extremities of said spring elements have hooking means for hooking said springs to one another to remain hooked when they are radially urged on their middle part against the inner face of said side wall groove.

3. Wristwatch according to claim 2, wherein said extremities of said spring elements are notched.

4

4. A wristwatch comprising a case, a side wall for said case, a removable outer ring engaged over said side wall, said side wall and ring having facing in said grooves in order to axially maintain said ring on said side wall, the middle part of said elements forming loops serving to secure a wristlet, a tube integral with said side wall and a winding button sliding thereon, and a space being provided between said side wall and ring, tubular element carried by said button and having an extremity movable in said space and able to contact said side wall and ring during axial movement of said button on said tube, said side wall and ring thereby forming a stop limiting movement of said button.

References Cited

UNITED STATES PATENTS

3,165,884	1/1965	Gwinner et al.	58—88W
2,559,238	7/1951	Wallin	58—88W

FOREIGN PATENTS

448,985	6/1936	England	58—88A
279,368	11/1951	Switzerland	58—88
407,884	9/1966	Switzerland	58—88W

RICHARD B. WILKINSON, Primary Examiner

G. H. MILLER, Jr., Assistant Examiner

U.S. Cl. X.R.

58—91