

No. 646,293.

Patented Mar. 27, 1900.

C. H. LOUTZENHISER.  
GYRATING SIEVE OR BOLTING MACHINE.

(Application filed Mar. 7, 1899.)

(No Model.)

4 Sheets—Sheet I.

Fig. 11.

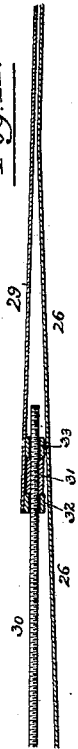

Fig. 1.

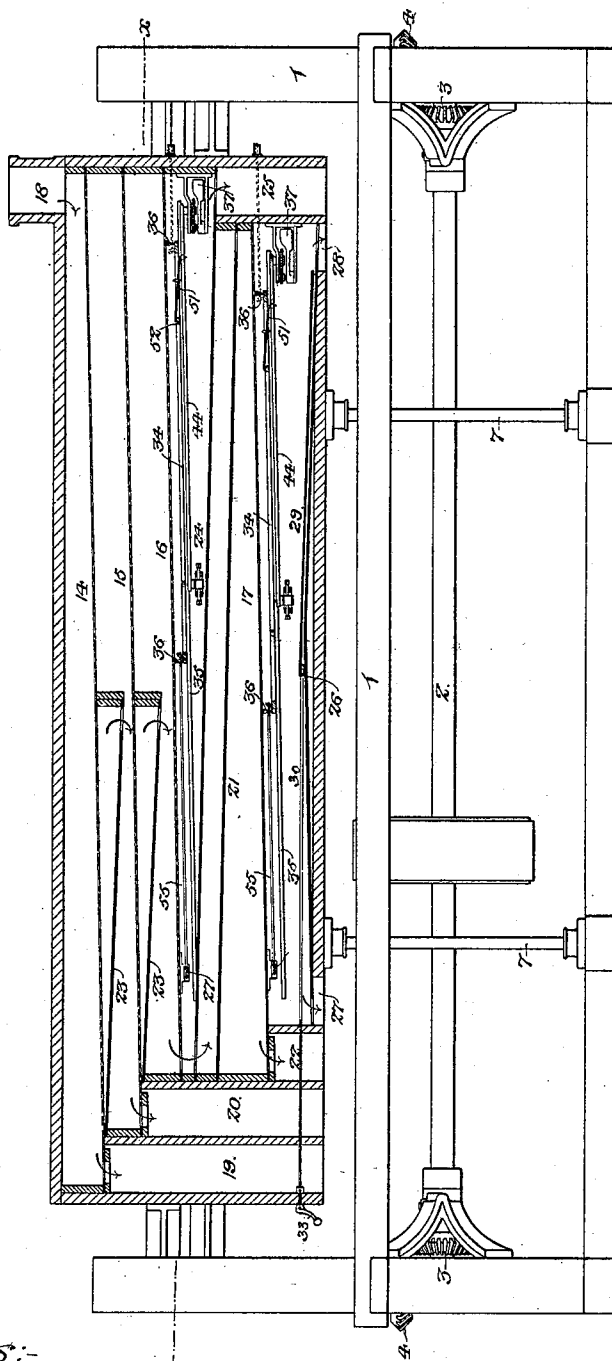
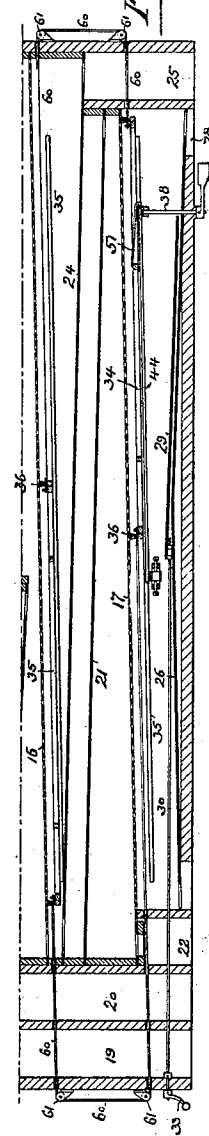

Fig. 12.



Witnesses:-

*Ramilton D. Turner*  
*Amie M. Lohickhead.*

Inventor:-

*Charles H. Loutzenhiser*  
By *Fis*, Attorneys:-  
*Howson & Howson*

No. 646,293.

Patented Mar. 27, 1900.

C. H. LOUTZENHISER.  
GYRATING SIEVE OR BOLTING MACHINE.

(Application filed Mar. 7, 1899.)

(No Model.)

4 Sheets—Sheet 2

*Fig. 2.*

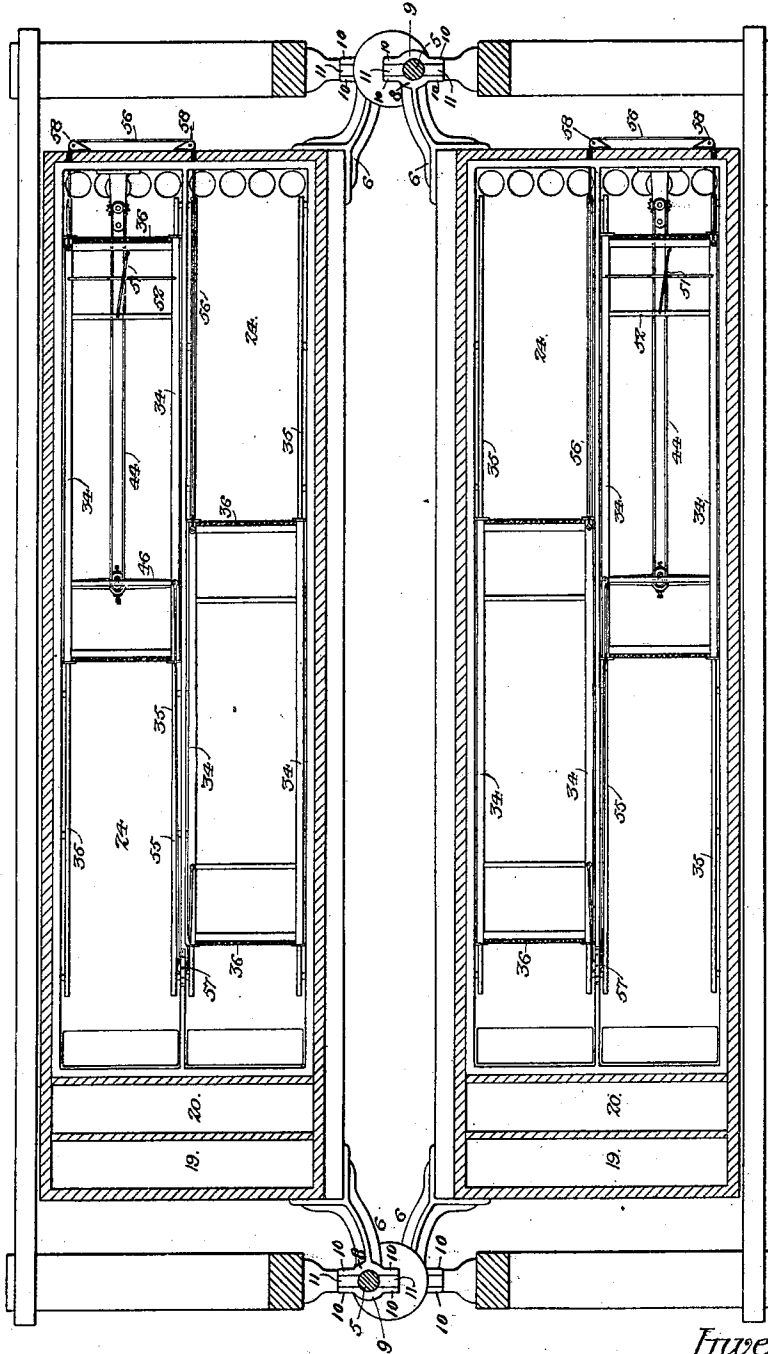

*Witnesses:-*  
*Hamilton D. Turner*  
*Amos M. Whithead.*

*Inventor:-*  
*Charles H. Loutzenhiser.*  
*By His Attorneys:-*  
*Howson & Howson*

No. 646,293.

Patented Mar. 27, 1900.

C. H. LOUTZENHISER.  
GYRATING SIEVE OR BOLTING MACHINE.

(No Model.)

(Application filed Mar. 7, 1899.)

4 Sheets—Sheet 3.

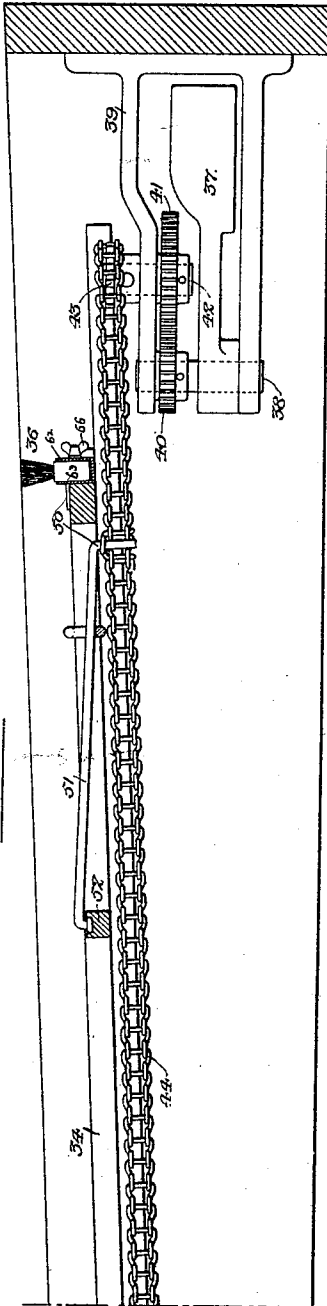

Fig. 3.

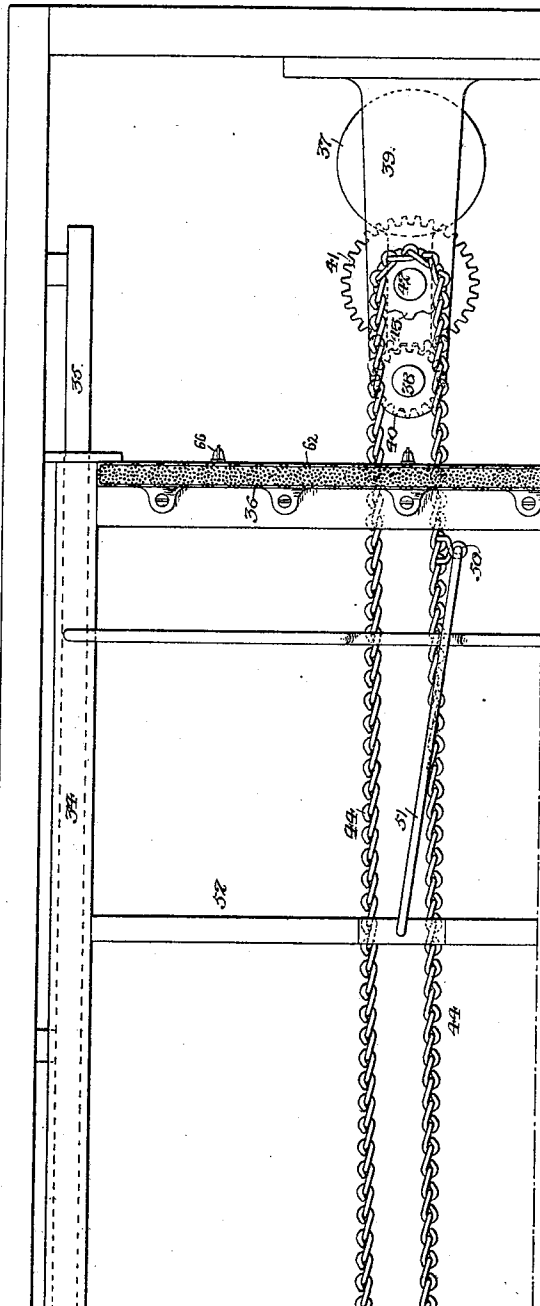

Fig. 4.

Witnesses:  
Hamilton D. Turner  
Louis H. Whitehead

Inventor:  
Charles H. Loutzenhiser  
by his Attorneys:  
Howson & Howson

No. 646,293.

Patented Mar. 27, 1900.

C. H. LOUTZENHISER.  
GYRATING SIEVE OR BOLTING MACHINE.

(Application filed Mar. 7, 1899.)

(No Model.)

4 Sheets—Sheet 4.

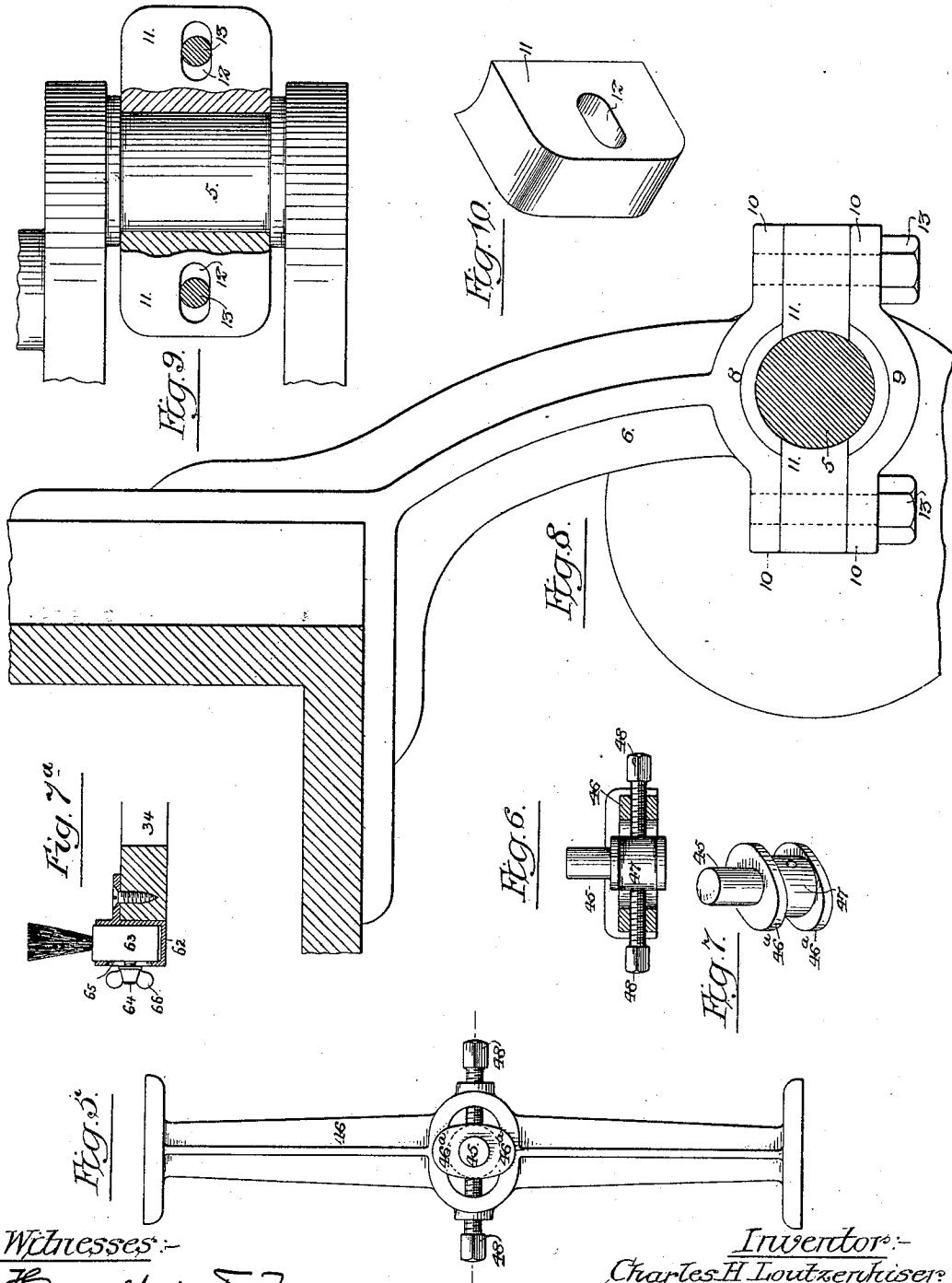

Witnesses:-  
Hamilton D. Turner  
Louis W. Whitehead.

Inventor:-  
Charles H. Loutzenhiser  
by his Attorneys:-  
Howson & Howson

# UNITED STATES PATENT OFFICE.

CHARLES H. LOUTZENHISER, OF PHILADELPHIA, PENNSYLVANIA, ASSIGNOR  
TO WALTER GRISCOM AND THOMAS McFEELY, OF SAME PLACE.

## GYRATING SIEVE OR BOLTING-MACHINE.

SPECIFICATION forming part of Letters Patent No. 646,293, dated March 27, 1900.

Application filed March 7, 1899. Serial No. 708,117. (No model.)

*To all whom it may concern:*

Be it known that I, CHARLES H. LOUTZENHISER, a citizen of the United States, residing in Philadelphia, Pennsylvania, have invented certain Improvements in Gyrating Sieves or Bolting-Machines, of which the following is a specification.

The objects of my invention are to provide for the effective cleaning of the sieves of a gyrating bolting-machine and to so construct the bearings for the crank-pins, whereby gy-  
rating motion is imparted to the sieve-boxes, that said bearings may be set up to compensate for wear without altering the distance between the centers of the upright crank-shafts. These objects I attain in the manner hereinafter set forth, reference being had to the accompanying drawings, in which—

Figure 1 is a longitudinal section, partly in elevation, of a gyrating sieve or bolting-machine constructed in accordance with my invention. Fig. 2 is a sectional plan view of the same on the line *x x*, Fig. 1, with the sieves removed. Figs. 3 and 4 are respectively a longitudinal section and a plan view, on an enlarged scale, of the mechanism for operating the sieve-cleaner. Figs. 5, 6, 7, and 7<sup>a</sup> are views also illustrating parts employed in connection with the sieve-cleaner. Figs. 8, 9, and 10 are views on an enlarged scale, illustrating the compensating bearing for the crank-pin, whereby gyrating motion is imparted to the sieve-boxes. Fig. 11 is an enlarged section of part of the cut-off device, and Fig. 12 is a longitudinal sectional view illustrating certain modifications of my invention.

The fixed frame of the machine (represented at 1 in Figs. 1 and 2) has bearings for a shaft 2, which drives, by means of bevel-gears 3 and 4 at the ends, opposite vertical shafts having the crank-pins 5, which engage with bearings forming part of brackets 6, connected to and projecting from the inner corners of the sieve-boxes, the latter being mounted upon rods 7, having the usual ball-and-socket or other universally-swinging joints at their upper and lower ends, so that as the vertical shafts are rotated gyrating motion will be imparted to each sieve-box.

As the crank-pin bearings are subjected

to wear, I construct them in the form of inner and outer segments 8 and 9, partially embracing the crank-pin and each having projecting wings 10, between which are confined blocks 11 of hard wood, antifriction metal, or other available material, these blocks being slotted, as shown at 12 in Figs. 9 and 10, for the reception of the confining-bolts 13, so that when the bearing shows signs of wear said confining-bolts may be slackened and the blocks 11 set up so as to bear snugly upon the crank-pin and then again secured in position. This adjustment of the blocks 11 is a lateral one, and hence there is no change in the longitudinal distance of the crank-shafts from each other, as there would have to be if the adjustment was one to compensate for wear in longitudinal direction.

The sieve-boxes each contain four screens or sieves 14, 15, 16, and 17, as shown in Fig. 1, the top screen 14 receiving through a feed-spout 18 the material to be bolted and discharging the tailings through a spout 19, the second screen 15 discharging its tailings through a spout 20, and the third screen 16 discharging its tailings onto an inclined directing-table 21, whereby they are led to the upper end of the bottom screen 17, which discharges its tailings through a spout 22. The material which passes through the meshes of the top screen 14 falls onto the screen 15 beneath, and the material which passes through the meshes of the latter screen falls onto the screen 16, and in order to provide for a more extended resieving than usual of the material which passes through the lower half of each of the screens 14 and 15 I provide beneath each of these screens an inclined returning-table 23, which extends from the tail end of the screen forwardly to any desired extent and collects all of the material passing through the meshes of the corresponding area of the screen above it and delivers said material from its forward end onto the screen beneath, so that all of the material passing through a considerable area of the lower half of either screen 14 or 15 is returned and compelled to pass over a corresponding area of the screen beneath it and is thereby more thoroughly sifted than if it dropped directly through the meshes of the upper screen onto

the corresponding portion of the screen beneath. The material passing through the meshes of the screen 16 falls upon an inclined directing-plate 24 and is discharged through a spout 25, and the material passing through the meshes of the screen 17 falls upon a double-inclined directing-plate 26, having its apex about the longitudinal center of the sieve-casing, one of the inclines discharging through an opening 27 at one end of the casing and the other through a discharge-opening 28 at the opposite end of the same. In connection with this double-inclined delivery-plate I use an adjustable cut-off plate 29, operated by a screw-rod 30, adapted to a nut 31, confined between lugs 32 on the under side of the plate, as shown in Fig. 11, the screw-rod having on the outside of the casing at the tail end a handle 33, whereby it may be conveniently turned, so as to cause the upper end of the plate 29 to project more or less beyond the apex of the double-inclined delivery-plate 26, and thereby cut off from that incline which delivers through the opening 27 more less of the material which would otherwise fall upon the same.

In order to provide for the cleaning of the sieves 16 and 17, I employ longitudinally-reciprocated frames 34, mounted so as to be free to slide upon guides 35, parallel with the sieves, each of these frames carrying rows of brushes 36, which bear upon the under side of the sieves, and as they are carried back and forth along the sieves keep the same clean.

In order to effect the automatic reciprocation of each brush-frame, I employ a weighted arm 37, secured to a shaft 38, which is mounted in suitable brackets 39 on the sieve-casing and has a spur-pinion 40, meshing with a spur-wheel 41 on a shaft 42, which is provided with a sprocket-wheel 43 for imparting motion to an endless chain 44, which also passes around a sprocket-wheel mounted on a pin 45, adjustable longitudinally in the slotted central portion of a cross-brace 46 of the sieve-casing, as shown in Figs. 5, 6, and 7, the pin having wings 46<sup>a</sup> for overlapping the central slotted portion of the brace and maintaining it in its proper vertical relation thereto and also having a block 47, which is acted upon by set-screws 48, passing through threaded openings in the brace, whereby the desired adjustment of the pin may be effected in order to maintain the chain 44 tight under all circumstances. The chain 44 has a projecting eye 50, with which engages one end of a rod 51, the opposite end of said rod engaging with a socket on a cross-bar 52 of the brush-frame. Owing to the gyrating movement of the sieve-box the weighted arm 37 is caused to rotate, thereby imparting corresponding movement to the sprocket-wheel 43 and causing the operation of the endless chain 44. As the eye 50 travels along one run of said chain it pulls the sieve-frame after it, and as it traverses the other run of the chain it pushes the sieve-frame ahead of it, thereby impart-

ing to said sieve-frame the longitudinal movements necessary to cause its brushes to act upon every part of the under side of the sieve in connection with which it operates.

Where there are two sieves side by side, I prefer to use the operating devices described in connection with one brush-frame only and to connect the two brush-frames by means of cords or chains and pulleys, so that movement of one brush-frame in one direction will cause movement of the other brush-frame to the same extent, but in the opposite direction. Thus, as shown in Fig. 2, one brush-frame is connected to the other by means of cords 55 and 56, the cord 55 passing around a pulley 57, mounted in the central division-bar of the sieve-box, and the cord 56 passing around pulleys 58 on the outside of the sieve-box at one end of the same. By this means a portion of the connecting-cord is exposed and serves as a telltale to indicate whether the brush-frames are moving properly and to serve also as a ready means of starting them when occasion requires. The same means may also be employed for imparting movement from one brush-frame to another frame above or below it. Thus in Fig. 12 I have shown upper and lower frames connected by cords or wires 60, passing around pulleys 61. In this case also I have shown the weighted arm 37 located outside of the sieve-box casing instead of on the inside of the same, and the chain 44 for operating the lower sieve-frame is driven directly from the shaft carrying the weighted arm instead of from a shaft geared thereto; the use of gearing not being essential to the proper carrying out of my invention, although preferred in most cases.

One of the main advantages of my invention arises from the fact that the operating chain or belt 44 presents its edge to the brush-frame instead of its flat side, so that the brush-frame travels in the same plane as the belt and can carry a series of brushes which are always in action, so that the entire length of the screen can be brushed by the use of a belt much less in length than the screen, whereas in a well-known class of sieve-cleaners in which brush-bars are carried directly by the flat side of a belt running at a plane at right angles to the sieve the brushes can only cover a length of sieve equal to the length of the run of the belt and each brush is out of action while it is traversing the return run of the belt. The arrangement which I have devised, moreover, is much more compact than that usually employed and both the driving-belt and its operating mechanism can be conveniently located in the space between the sieve and the directing-plate below it.

In order to compensate for wear of the brushes and also to cause them to bear with any desired degree of pressure against the under side of the sieve, I prefer to mount the brush-block adjustably upon the brush-frame, one method of accomplishing this being shown

in Fig. 7<sup>a</sup>, in which 62 represents a box or receptacle secured to the end bar of the brush-frame and containing the brush-block 63, which has a set-screw 64 passing through a slot 65 in the outer face of the box 62 and provided with a nut 66, so that the brush-block 63 can be adjusted to different vertical positions in the box 62 and secured after adjustment.

Having thus described my invention, I claim and desire to secure by Letters Patent—

1. The combination of a gyrating sieve-box, an upright crank-shaft, and a bracket mounted on the sieve-box and having a crank-pin bearing consisting of inner and outer segments, confining between them radially-adjustable blocks, which bear at their inner ends upon the crank-pin, substantially as specified.

2. The combination of a gyrating sieve-box, upright crank-shafts and crank-shaft bearings on the sieve-box, having laterally-adjustable blocks for taking up wear, whereby the longitudinal distance between the crank-shafts is not changed, substantially as specified.

3. The combination of a gyrating sieve or bolting-machine with a reciprocating brush-frame, a weighted arm which is caused to rotate by the gyrating movement of the sieve-box, and means whereby the rotating movement of said arm is caused to impart reciprocating movement to the brush-frame, substantially as specified.

4. The combination in a gyrating sieve or bolting-machine, of a reciprocating brush-

frame, a weighted arm which is caused to rotate by the gyrating movement of the sieve-box, an endless chain to which the reciprocating brush-frame is connected, and means whereby said chain is operated by the rotating movement of the weighted arm, substantially as specified.

5. The combination in a gyrating sieve or bolting-machine, of a reciprocating brush-frame, an endless belt presenting its edge to said brush-frame, connections between the brush-frame and belt, a shaft having a weighted arm which is caused to rotate by the gyrating movement of the sieve-box, and means whereby said shaft is caused to drive the endless belt, substantially as specified.

6. The combination in a gyrating sieve or bolting-machine, of a reciprocating brush-frame, an endless belt presenting its edge to said brush-frame, connections between the brush-frame and belt, a shaft having a weighted arm which is caused to rotate by the gyrating movement of the sieve-box, and means whereby said shaft is caused to drive the endless belt, the brush-frame, belt, weighted arm, and transmitting devices all being disposed in the space between the sieve and a directing-plate beneath the same, substantially as specified.

In testimony whereof I have signed my name to this specification in the presence of two subscribing witnesses.

CHARLES H. LOUTZENHISER.

Witnesses:

F. E. BECHTOLD,  
JOS. H. KLEIN.