

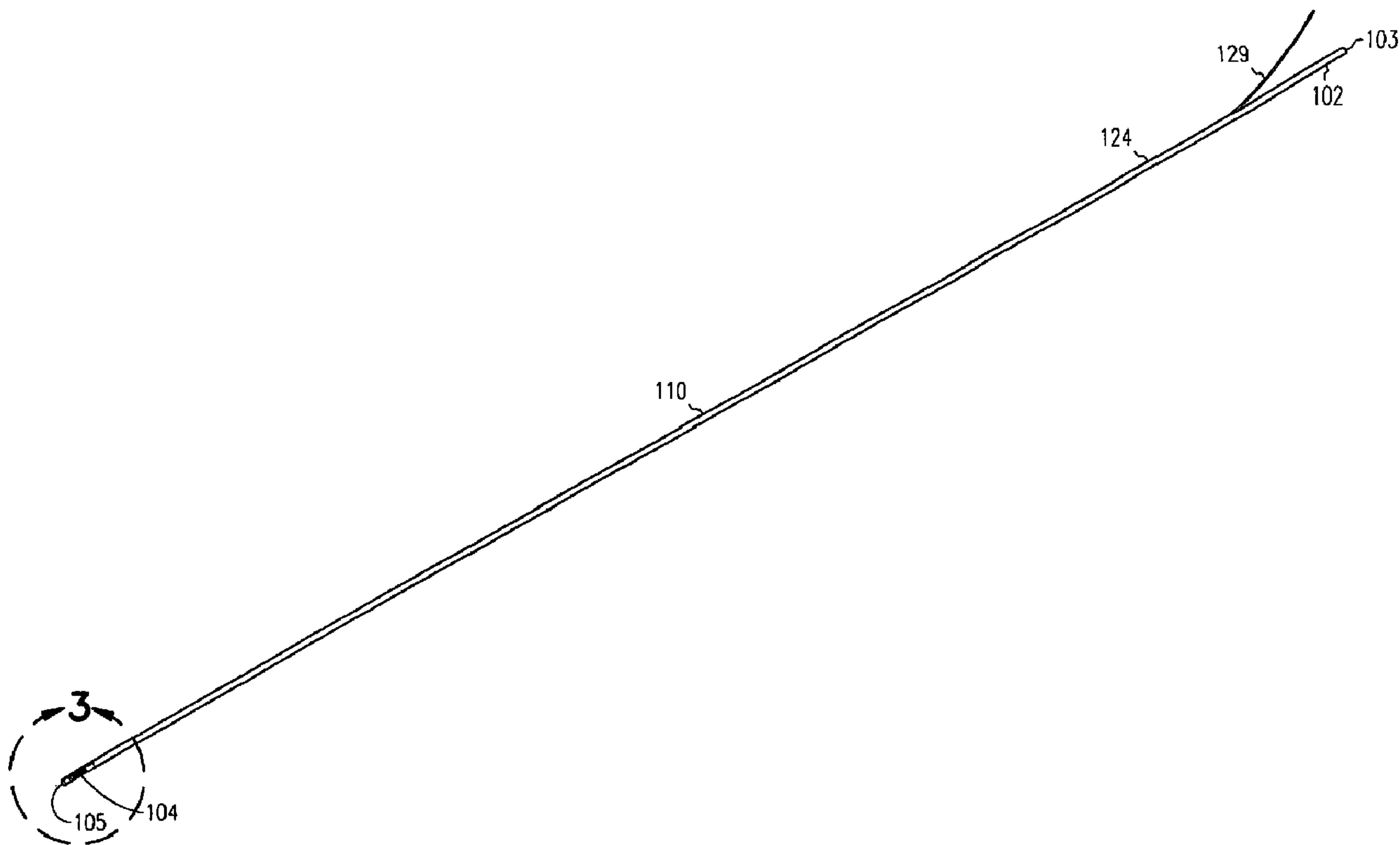

(86) Date de dépôt PCT/PCT Filing Date: 2003/06/25
 (87) Date publication PCT/PCT Publication Date: 2003/12/31
 (45) Date de délivrance/Issue Date: 2010/04/20
 (85) Entrée phase nationale/National Entry: 2004/12/14
 (86) N° demande PCT/PCT Application No.: US 2003/019768
 (87) N° publication PCT/PCT Publication No.: 2004/000404
 (30) Priorité/Priority: 2002/06/25 (US10/179,124)

(51) Cl.Int./Int.Cl. *A61M 25/01* (2006.01),
A61M 25/00 (2006.01)
 (72) Inventeur/Inventor:
HONEBRINK, BRIAN, US
 (73) Propriétaire/Owner:
GREATBATCH LTD., US
 (74) Agent: GOWLING LAFLEUR HENDERSON LLP

(54) Titre : ENSEMBLE CATHETER A LUMIERE DE SORTIE A PAROI LATERALE ET PROCEDE ASSOCIE
 (54) Title: CATHETER ASSEMBLY WITH SIDE WALL EXIT LUMEN AND METHOD THEREFOR



(57) Abrégé/Abstract:

A catheter assembly (100) includes a catheter body (110) that extends from a distal end (104) to a proximal end (102). The catheter body includes a first delivery lumen (130), and a second lumen, such as an actuator lumen (122), where the second lumen extends from a position near or at the distal end to an intermediate portion that does not extend through the proximal end of the catheter body.

(12) INTERNATIONAL APPLICATION PUBLISHED UNDER THE PATENT COOPERATION TREATY (PCT)

(19) World Intellectual Property
Organization
International Bureau



(43) International Publication Date
31 December 2003 (31.12.2003)

PCT

(10) International Publication Number
WO 2004/000404 A1

- (51) International Patent Classification⁷: **A61M 25/01**
- (21) International Application Number:
PCT/US2003/019768
- (22) International Filing Date: 25 June 2003 (25.06.2003)
- (25) Filing Language: English
- (26) Publication Language: English
- (30) Priority Data:
10/179,124 25 June 2002 (25.06.2002) US
- (71) Applicant (for all designated States except US): **MEDAM-ICUS, INC.** [US/US]; 15301 Highway 55 West, Minneapolis, MN 55447 (US).
- (72) Inventor; and
- (75) Inventor/Applicant (for US only): **HONEBRINK, Brian** [US/US]; 126 North Martha Street, Stillwater, MN 55082 (US).
- (74) Agents: **STEFFEY, Charles E.** et al.; P.O. Box 2938, Minneapolis, MN 55402 (US).
- (81) Designated States (*national*): AE, AG, AL, AM, AT, AU, AZ, BA, BB, BG, BR, BY, BZ, CA, CH, CN, CO, CR, CU, CZ, DE, DK, DM, DZ, EC, EE, ES, FI, GB, GD, GE, GH, GM, HR, HU, ID, IL, IN, IS, JP, KE, KG, KP, KR, KZ, LC, LK, LR, LS, LT, LU, LV, MA, MD, MG, MK, MN, MW, MX, MZ, NI, NO, NZ, OM, PG, PH, PL, PT, RO, RU, SC, SD, SE, SG, SK, SL, TJ, TM, TN, TR, TT, TZ, UA, UG, US, UZ, VC, VN, YU, ZA, ZM, ZW.
- (84) Designated States (*regional*): ARIPO patent (GH, GM, KE, LS, MW, MZ, SD, SL, SZ, TZ, UG, ZM, ZW), Eurasian patent (AM, AZ, BY, KG, KZ, MD, RU, TJ, TM), European patent (AT, BE, BG, CH, CY, CZ, DE, DK, EE, ES, FI, FR, GB, GR, HU, IE, IT, LU, MC, NL, PT, RO, SE, SI, SK, TR), OAPI patent (BF, BJ, CF, CG, CI, CM, GA, GN, GQ, GW, ML, MR, NE, SN, TD, TG).
- Published:**
- with international search report
 - before the expiration of the time limit for amending the claims and to be republished in the event of receipt of amendments
- For two-letter codes and other abbreviations, refer to the "Guidance Notes on Codes and Abbreviations" appearing at the beginning of each regular issue of the PCT Gazette.

(54) Title: CATHETER ASSEMBLY WITH SIDE WALL EXIT LUMEN AND METHOD THEREFOR

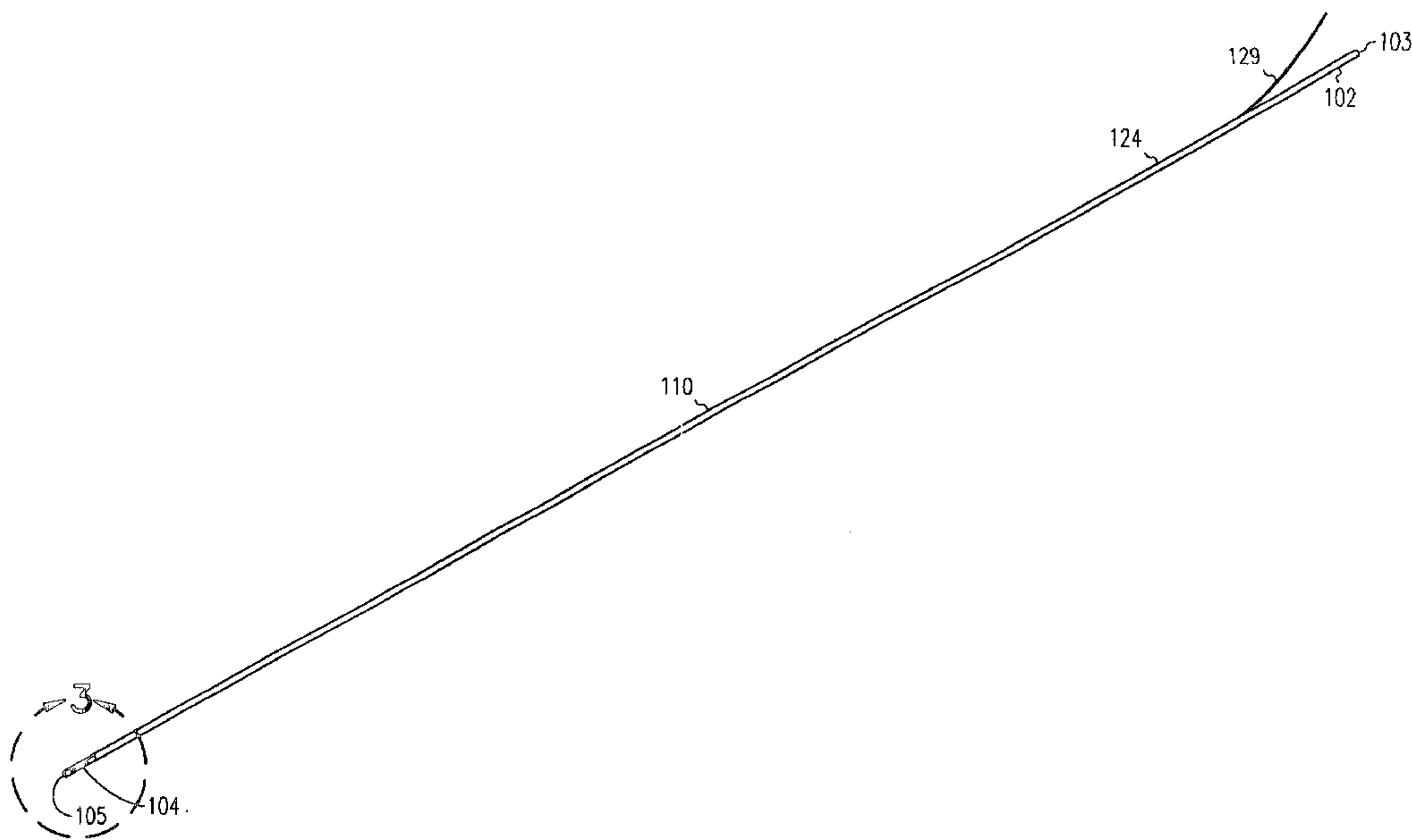

(57) Abstract: A catheter assembly (100) includes a catheter body (110) that extends from a distal end (104) to a proximal end (102). The catheter body includes a first delivery lumen (130), and a second lumen, such as an actuator lumen (122), where the second lumen extends from a position near or at the distal end to an intermediate portion that does not extend through the proximal end of the catheter body.

WO 2004/000404 A1

**CATHETER ASSEMBLY WITH SIDE WALL EXIT
LUMEN AND METHOD THEREFOR**

5

Technical Field

The present application relates generally to a deflectable catheter assembly.

10

Background

Increase in the use of stents, leads, and ablation techniques in branch vessels has provided an increased demand on the placement techniques for these devices. For some procedures, it is necessary to initially position a guidewire into a desired part of the lumen of a desired vessel or duct, such as a blood vessel. After the guidewire is positioned within the desired location, a catheter or other tubular device may be positioned over the guidewire and used to convey other medical instruments into the desired blood vessel or duct.

15

Alternatively, a guiding catheter is used to negotiate the vasculature of a patient. One example of a guiding catheter is described in U.S. Pat. No. 4,898,577 to Badger et al. The Badger guiding catheter includes a single elongate shaft that has a deflectable distal portion controllable by a pull wire. Once the distal portion is at the required deflection or location within the patient, the guidewire or medical instrument is fed through a delivery lumen of the catheter.

20

The deflectable catheter is controlled at a proximal end of the catheter by a control handle that operates a pull wire to deflect the catheter, for example, as shown in U.S. Patent No. 6,171,277. In many conventional catheters, the pull wire is disposed within a pull wire lumen, where the pull wire lumen extends from the distal portion of the shaft through an opening at the proximal end surface of the shaft. The pull wire opening at the proximal end surface is directly adjacent to a delivery lumen that extends from the distal end through the proximal end surface, which has several drawbacks. For instance, blood which enters the delivery lumen at the distal end can travel to the proximal end of the

25

30

shaft and enter the pull wire lumen, potentially resulting in contamination issues. Another potential drawback is when the blood entering the pull wire lumen clots within the pull wire lumen or around the pull wire, the operation of the pull wire is impeded, rendering it difficult to manipulate the distal end of the shaft.

- 5 Another potential drawback with this pull wire lumen and delivery lumen is the risk of embolism.

Accordingly, what is needed is a deflectable catheter that overcomes the shortcomings of previous deflectable catheters. What is further needed is a deflectable catheter that allows for more accurate positioning of the distal end of
10 the deflectable catheter.

Summary

A deflectable catheter assembly includes a catheter body extending from a deflectable distal end to a proximal end and having an intermediate portion
15 therebetween. The catheter body includes a first lumen and a second lumen, where the first lumen extends from the deflectable distal end through the proximal end. The second lumen extends from a position near the deflectable distal end to the intermediate portion, but not through the proximal end, and forming an exit lumen in a side wall of the catheter body.

20 The deflectable catheter assembly provides a catheter assembly that is easy to use and manipulate, and does not interfere with the physician's ability to manipulate the deflectable catheter assembly. Furthermore, the catheter assembly design assists in preventing air leakage from the actuator lumen. The catheter assembly further prevents co-mingling of fluids from the delivery lumen
25 to the actuator lumen, and prevents fluids from entering the actuator lumen and/or the accessory lumen.

These and other embodiments, aspects, advantages, and features of the present invention will be set forth in part in the description which follows, and in part will become apparent to those skilled in the art by reference to the following
30 description of the invention and referenced drawings or by practice of the invention. The aspects, advantages, and features of the invention are realized

and attained by means of the instrumentalities, procedures, and combinations particularly pointed out in the appended claims and their equivalents.

Brief Description of the Drawings

- 5 Figure 1A is a perspective view illustrating a deflectable catheter assembly constructed in accordance with one embodiment.
- Figure 1B is a perspective view illustrating a deflectable catheter assembly constructed in accordance with one
- 10 Figure 2 is a perspective view illustrating a deflectable catheter body constructed in accordance with one embodiment.
- Figure 3 is a perspective view illustrating a distal portion of the deflectable catheter body constructed in accordance with
- 15 Figure 4 is an end view of the distal end of the deflectable catheter assembly constructed in accordance with one embodiment.
- Figure 5 is an end view of the proximal end of the deflectable catheter assembly constructed in accordance with one
- 20 Figure 6 is a cross-sectional view illustrating a portion of the deflectable catheter assembly constructed in accordance with one embodiment.
- Figure 7 is a side view illustrating a portion of a catheter body constructed in accordance with another embodiment.
- 25 Figure 8 is a cross-sectional view illustrating a distal end portion of a catheter body constructed in accordance with another embodiment.

Figure 9 is a perspective view illustrating a proximal end portion of a catheter body constructed in accordance with one embodiment.

5

Description of the Embodiments

In the following detailed description, reference is made to the accompanying drawings which form a part hereof, and in which is shown by way of illustration specific embodiments in which the invention may be practiced. These embodiments are described in sufficient detail to enable those skilled in the art to practice the invention, and it is to be understood that other embodiments may be utilized and that structural changes may be made without departing from the scope of the present invention. Therefore, the following detailed description is not to be taken in a limiting sense, and the scope of the subject matter of this application is defined by the appended claims and their equivalents.

15

Figures 1A and 1B illustrate a deflectable catheter assembly 100, where Figure 1A illustrates the deflectable catheter assembly 100 in an articulated position, and Figure 1B illustrates the deflectable catheter assembly 100 in an unarticulated position. The deflectable catheter assembly 100 includes a deflectable catheter body 110 and a handle assembly 150 that houses steering mechanisms for deflection of the catheter body 110. The handle assembly 150 includes a housing, and at least a portion of the body 110 is disposed within the housing. The handle assembly 150 allows for the deflection of a distal end of the catheter body 110. In one option, the pull wire 120 is connected to an actuator that is slid or rotated to apply tension to the pull wire 120. As tension is applied to the pull wire 120, the pull wire anchor at the distal end of the catheter body 110 is pulled causing the distal portion of the catheter body 110 to curve in a predetermined direction or directions.

20

25

With reference to Figure 2, the catheter body 110 comprises an elongate tubular construction that is flexible yet substantially non-compressible along its length. The deflectable catheter body 110 extends from a proximal end 102 to a

30

distal end 104, where the distal end 104 is disposed within a patient. At the proximal end 102 is a proximal tip 103, and at the distal end 104 is a distal tip 105. At the proximal end 102, the physician controls the deflection of the deflectable catheter body 110 with the handle assembly 150 (Figures 1A and 1B) and a pull wire 120 (Figure 3), as further described below. The distal end 104 is deflected to traverse various branch vessels with the catheter assembly 100 (Figure 1).

Figure 3 illustrates a partial cut-away view of Figure 2, including the distal end 104 of the catheter body 110. The catheter body 110 includes a pull wire anchor 121 that is secured to the catheter body 110. Secured to the pull wire anchor 121 is the pull wire 120. The pull wire 120 extends from a proximal end to a pull wire distal end. The pull wire distal end is mechanically secured to the pull wire anchor 121 with a physical attachment, for example, in one embodiment, formed by spot welding. As the pull wire 120 is longitudinally pulled, the pull wire 120 pulls on the pull wire anchor 121, and the distal end of the catheter body deflects. It should be noted that the pull wire can be secured to the distal end 104 of the catheter body 110 in other manners. The pull wire anchor 121, in one option, comprises a marker band 119 that is viewable, for example, under fluoroscopy. In one option, the catheter body 110 includes a stiffening member embedded therein, such as a braided stainless steel member 111. The stiffening member facilitates rotation of the distal end 104 from the proximal end 102, and also assists in preventing the catheter body 110 from collapsing.

Figure 4 illustrates an end-view of the catheter body 110 at its distal end 104 (Figure 2). The catheter body 110 is further defined by an outer shaft surface 112. Disposed within the deflectable catheter body 110 includes at least one delivery lumen 130, or a first lumen, that extends from the proximal end through the catheter body distal end 104. The delivery lumen 130, or first lumen, extends through the housing so that instruments can be disposed therethrough. In one option, the delivery lumen 130 is lined with liner material

132, for example, PTFE. The lining of the delivery lumen 130 allows for instruments to be more easily inserted therethrough.

The delivery lumen 130 provides a passage from the controlling end to the distal end, such that a physician can insert a device or fluid in at the proximal end and it will travel through the catheter body 110 to the distal end 5 104 (Figure 2), where it will exit the catheter body 110. The deflectable nature of the body 110, in conjunction with the steering assembly, allows for a physician to direct the application of a device and/or medicine or fluid to a particular location within a patient. The delivery lumen 130 is configured to receive a variety of medical devices 134 therethrough. For example, suitable 10 devices include, but are not limited to, leads, stents, dilators, guidewires, EP mapping catheters, ablation devices, etc. Alternatively, fluids and/or medicine can be distributed and targeted to a certain location using the deflectable catheter assembly 100 (Figure 1A).

15 As mentioned above, the deflectable catheter assembly 100 (Figure 1A) further includes a pull wire 120 associated therewith, where the pull wire 120 is received within an actuator lumen 122. The actuator lumen 122 is disposed within the catheter body 110, and the pull wire 120 is movably disposed within the actuator lumen 122. The actuator lumen 122 extends from a location near 20 or at the distal end 104 (see Figure 3) to an intermediate location that does not extend through the proximal end 102 (see Figure 2). For example, the actuator lumen 122 terminates at a location in a side wall 124 of the catheter body 110. The pull wire 120 exits through the side wall 124 and is coupled with an actuator within the housing. As the actuator is moved or manipulated, the pull 25 wire 120 pulls on the distal end and deflects the catheter body.

Figure 5 illustrates an end view of the catheter body 110 at the proximal end. The lumen 122 does not extend to the proximal end nor to the proximal tip of the catheter body 110. Therefore, there is no cross-contamination of fluids or gasses from the delivery lumen 130, a first lumen, to the actuator lumen 122, a 30 second lumen, or vice versa.

In one option, the actuator lumen 122 further includes an actuator lumen liner 126 therein. The actuator lumen liner 126 forms a lumen therein, where the lumen receives the pull wire 120 therein. The actuator lumen liner 126 is formed of PTFE in one option. Other suitable materials for the actuator lumen liner 126 include, but are not limited to, FEP or polyether-block-amide.

In yet another option, the actuator lumen liner 126 further includes a stiffening member such as braided material. The braided material assists in preventing the actuator lumen liner 126 from collapsing when the actuator lumen liner 126 is pulled out a side lumen, as further described below.

As shown in Figure 3, the actuator lumen liner 126 extends from a location 131 near the distal end 104. In one option, the distal end 127 of the actuator lumen liner 126 is spaced away from the anchor 121 a distance "d". This allows for improved manufacturability of the catheter body 110 assembly. For instance, if the pull wire is not perfectly aligned with the pull wire anchor 121, this can result in irregularities in the outer diameter if the actuator lumen liner 126 extends up to the anchor 121.

The actuator lumen liner 126 extends along the catheter body 110 to a location near the proximal end 102, as shown in Figure 6. The actuator liner 126 exits through a side wall 124 of the catheter body 110 at 129. For example, in one option, the actuator lumen liner 126 is pulled through the side wall 124 of the catheter body 110 through an exit lumen 128 of the catheter body 110. The actuator lumen liner 126 does not continue within the catheter body 110 through the proximal end 102, and does not continue through the proximal tip of the catheter body 110. The actuator lumen liner 126 assists in sealing the proximal end of the catheter body 110, which prevents fluids exiting or co-mingling at the proximal end of the catheter body 110. In one option, a seal is formed around the actuator lumen liner 126 with material 188 reflowed around a portion of the actuator lumen liner 126.

Figure 7 illustrates another option for the catheter body 110'. The catheter body 110' includes at least a first segment 150 and a second segment 152. In one option, the first segment 150 has a different durometer than the

second segment 152. The first segment 150 is formed separate from the second segment, and the first segment includes a delivery lumen and an actuator lumen therein, as discussed above. The second segment 152 includes a delivery lumen, as discussed above. However, there are no lumens in the second
5 segment 152 which are coupled with the actuator lumen. In one embodiment, the second segment 152 forms the proximal end of the catheter body 110', and the first segment 150 forms the intermediate portion of the catheter body 110'. In another option, a third segment having a different structure forms the distal end of the catheter body 110'. It should be noted that more segments are further
10 options.

In yet another option, the catheter body 110' includes a notch 160 in the second segment 152 at a location 154 adjacent the first segment 150. The notch 160 allows for the actuator lumen liner (discussed above) to transition and exit more easily from an interior portion of the first segment 150, where the lumen
15 and/or the liner do not extend through the proximal end surface of the catheter body 110'. The stress on the actuator lumen liner is reduced, and a smoother transition occurs.

To form the catheter assembly, in one example, the delivery lumen liner is placed over a mandrel, and the actuator lumen liner is threaded over the pull
20 wire and placed over the delivery lumen liner. The pull wire anchor is placed over the delivery lumen liner and coupled with the pull wire. Stiffening material is optionally placed over the delivery lumen liner and the actuator lumen liner. Outer tubing is placed over the delivery lumen liner, which will form the outer surface of the catheter body. The items are held together, for
25 example, by placing shrink tubing thereover and heating the shrink tubing. The items are reflowed together, a process which blends the material of the outer tubing, actuator lumen liner, and the delivery lumen liner. The shrink tubing is removed from the assembly.

To form the proximal end, an outer jacket is slid over a proximal end of
30 the delivery lumen liner, but not over the actuator lumen liner. The outer jacket abuts the first outer jacket discussed above, and the items are secured together,

for example, by heat shrink tubing. These elements are reflowed together, and the shrink tubing is removed. The deflectable catheter body assembly is coupled with a handle assembly with a steering mechanism to form the deflectable catheter assembly.

5 In another embodiment, as shown in Figures 8 and 9, the catheter assembly 100" further includes an accessory lumen 190, or a second lumen. It should be noted that the embodiments shown in Figures 8 and 9 can be incorporated with any of the above-discussed embodiments. The accessory lumen 190, or second lumen, is disposed adjacent to the delivery lumen 130, and in one option, the accessory lumen 190 has a substantially smaller diameter than the delivery lumen 130. The delivery lumen 130, as discussed above, extends from a location in the distal end surface 170 through the proximal tip 172. The accessory lumen 190 extends from a location, in one option, in the distal tip 170 to a location 180 not in the proximal tip 172, for example, terminating at a location on the side wall 124 of the catheter body 110.

15 In another option, a liner 192 is disposed within the accessory lumen 190. The liner 192 includes, but is not limited to, the materials discussed above for the actuator lumen. In yet another option, a stiffening member, such as a braided member, is disposed adjacent to, or surrounding the accessory lumen 20 190, which assists in preventing the accessory lumen 190 from collapsing. The accessory lumen 190 is sized to receive therein accessories 194. For instance, a fiber optic instrument is disposed within the accessory lumen 190. The fiber optic instrument can be used to assist in directing the distal end of the catheter body 110 within the patient. This allows for a reduction or elimination of 25 radiation exposure, for example, radiation exposure that occurs during fluoroscopic procedures. Other types of instruments can be disposed in the accessory lumen 190 as well, for example, an instrument 194 can include one or more sensors 196 thereon.

30 To form the catheter assembly 100", the delivery lumen liner is placed over a mandrel, and the optional actuator lumen liner is optionally threaded over the pull wire and placed over the delivery lumen liner. The pull wire anchor is

placed over the delivery lumen liner and coupled with the pull wire. An instrument, such as an instrument with a sensor or an instrument such as a fiber optic instrument is placed over the delivery lumen liner. Stiffening material is optionally placed over the delivery lumen liner, the actuator lumen liner, and the instrument. Outer tubing is placed over the delivery lumen liner, the optional actuator lumen liner, and the instrument, which will form the outer surface of the catheter body. The items are held together, for example, by placing shrink tubing thereover and heating the shrink tubing. The items are reflowed together, a process which blends the material of the outer tubing, actuator lumen liner, the instrument, and the delivery lumen liner. The shrink tubing is removed from the assembly.

To form the proximal end of the catheter assembly, an outer jacket is slid over a proximal end of the delivery lumen liner, but not over the actuator lumen liner nor the instrument. The outer jacket abuts the first outer jacket discussed above, and the items are secured together, for example, by heat shrink tubing. These elements are reflowed together, and the shrink tubing is removed. The deflectable catheter body assembly is coupled with a handle assembly with a steering mechanism to form the deflectable catheter assembly.

Advantageously, the deflectable catheter assembly provides a catheter assembly that is easy to use and manipulate, and does not interfere with the physician's ability to manipulate the deflectable catheter assembly. Furthermore, the catheter assembly design assists in preventing leakage from the actuator lumen and/or the accessory lumen. The catheter assembly further prevents co-mingling of fluids from the delivery lumen to the actuator lumen and/or the accessory lumen, and prevents fluids from entering the actuator lumen and/or the accessory lumen. The accessory lumen and/or the accessory lumen provide for more flexibility during implant procedures, and provides for more options with the catheter assembly.

It is to be understood that the above description is intended to be illustrative, and not restrictive. Many other embodiments will be apparent to

those of skill in the art upon reading and understanding the above description. It should be noted that embodiments discussed in different portions of the description or referred to in different drawings can be combined to form additional embodiments of the present invention. Furthermore, although a
5 deflectable catheter assembly has been discussed throughout, it should be understood that the actuator lumen and the accessory lumen, and the various combinations discussed and/or shown in the application can be incorporated within other types of catheter assemblies, including, but not limited to, radiopaque catheter assemblies, non-deflectable catheter assemblies or slittable
10 catheter assemblies, or slittable catheter assemblies, or catheter assemblies removable in any fashion from instruments disposed therein. The scope of the invention should, therefore, be determined with reference to the appended claims, along with the full scope of equivalents to which such claims are entitled.

15

What is claimed is:

1. A deflatable catheter assembly comprising:
 - a catheter body extending from a deflatable distal end to a proximal end and having an intermediate portion therebetween;
 - the catheter body including a first delivery lumen and a second lumen;
 - the first delivery lumen extending from the deflatable distal end through the proximal end;
 - the second lumen extending from a position near the deflatable distal end to the intermediate portion and not through the proximal end;
 - the second lumen exiting the catheter body and forming an exit lumen on a side wall of the catheter body; and
 - a liner including a lumen therein, at least a portion of the liner extends outside of the catheter body, and the lumen of the liner is in communication with the second lumen at the exit lumen, and the catheter body seals around the liner at the exit lumen.
2. The deflatable catheter assembly as recited in claim 1, wherein a portion of the catheter body is disposed within a housing, and the first delivery lumen extends through the housing.
3. The deflatable catheter assembly as recited in any of claims 1 or 2, further comprising a second lumen liner disposed within the second lumen.
4. The deflatable catheter assembly as recited in any of claims 1 - 3, further comprising a pull wire disposed within the second lumen.
5. The deflatable catheter assembly as recited in any of claims 3 or 4, wherein the second lumen liner exits the catheter body through an exit lumen on a side wall of the catheter body.

6. The deflatable catheter assembly as recited in any of claims 3 - 5, further comprising a stiffening member coupled with the second lumen liner.
7. The deflatable catheter assembly as recited in any of claims 3 - 6, wherein the second lumen liner is formed of PTFE.
8. The deflatable catheter assembly as recited in any of claims 4 - 7, wherein the pull wire exits through the exit lumen.
9. The deflatable catheter assembly as recited in any of claims 1 - 8, further comprising a delivery lumen liner disposed within the first delivery lumen.
10. The deflatable catheter assembly as recited in any of claims 1 - 9, wherein the catheter body is slittable without damage to an instrument disposed therein.
11. The deflatable catheter assembly as recited in any of claims 1 - 10, wherein the second lumen is an actuator lumen.
12. The deflatable catheter assembly as recited in any of claims 1 - 10, wherein the second lumen is an accessory lumen.
13. The deflatable catheter assembly as recited in claim 12, further comprising an actuator lumen extending from a location near the distal end and terminating in the side wall.
14. The deflatable catheter assembly as recited in any of claims 12 and 13, further comprising an instrument disposed within the accessory lumen.
15. The deflatable catheter assembly as recited in any of claims 12 - 13, further comprising a sensor at least partially disposed within the accessory lumen.

16. The deflectable catheter assembly as recited in claim 14, wherein the instrument includes a fiber optic assembly.

17. The deflectable catheter assembly as recited in any of claims 12 - 16, wherein the accessory lumen has a substantially smaller diameter than the delivery lumen.

18. A method comprising:

forming a first delivery lumen within a deflectable catheter assembly having a catheter body extending from a proximal end to a distal end, the first delivery lumen extending from the catheter distal end through the catheter proximal end;

forming a second lumen along only a portion of the catheter body, and a proximal end of the second lumen within the catheter body is distal relative to the proximal end of the catheter;

terminating the second lumen at an exit lumen in a sidewall of the catheter body distal to the catheter proximal end, where the exit lumen is continuous with the second lumen;

coupling a liner with the catheter body at the exit lumen, the liner includes a lumen in communication with the second lumen, and the liner extends outside of the catheter body from the exit lumen; and

sealing the catheter body around the liner at the exit lumen.

19. The method as recited in claim 18, further comprising disposing a pull wire within the second lumen and the lumen of the liner.

20. The method as recited in any of claims 18 - 19, further comprising disposing a medical instrument through the first delivery lumen and through the distal end of the catheter body.

21. The method as recited in any of claims 18 - 20, further comprising placing a liner within the first delivery lumen.

22. The method as recited in any of claims 18 - 21, further comprising sealing the second lumen around the liner at the exit lumen, and the liner extends outside of the catheter body toward the proximal end of the catheter with the exit lumen therein.

23. The deflectable catheter assembly as recited in any of claims 1-17, wherein the portion of the liner extends from the exit lumen toward the proximal end of the catheter.

24. The method as recited in any of claims 18-23, wherein coupling the liner with the catheter body at the exit lumen includes coupling the liner with the catheter body at the exit lumen and the liner extends along the catheter body toward the proximal end of the catheter.

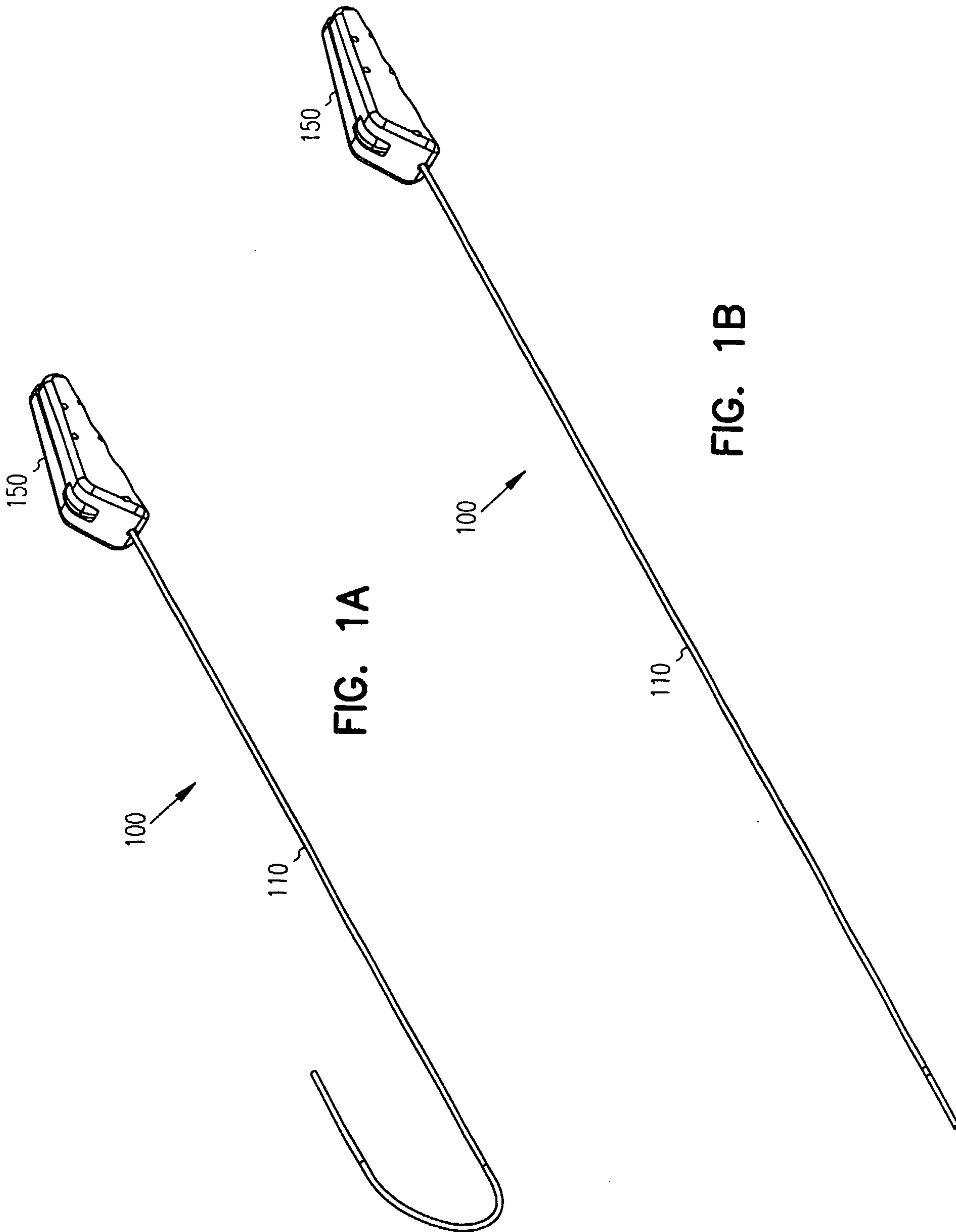

FIG. 1A

FIG. 1B

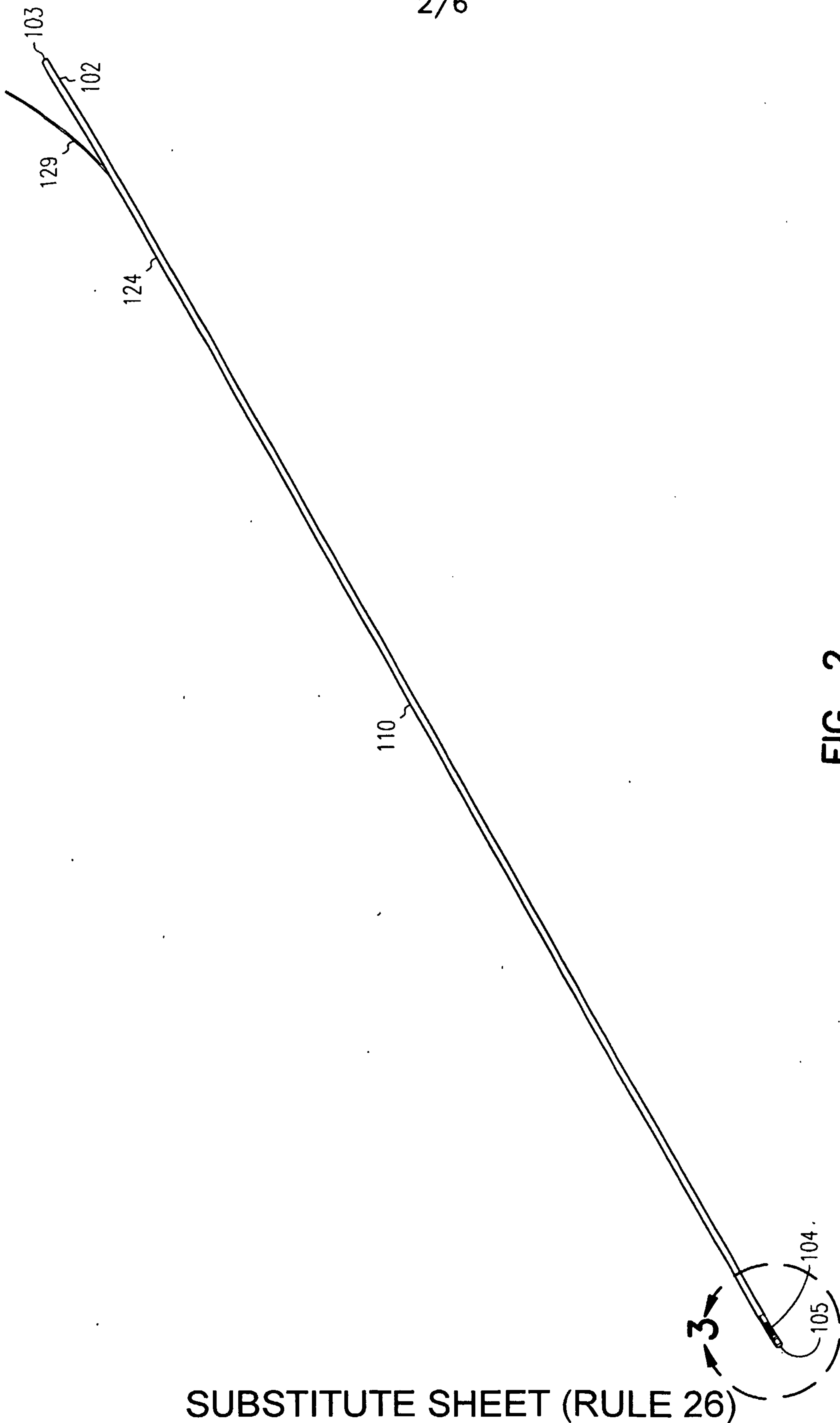

FIG. 2

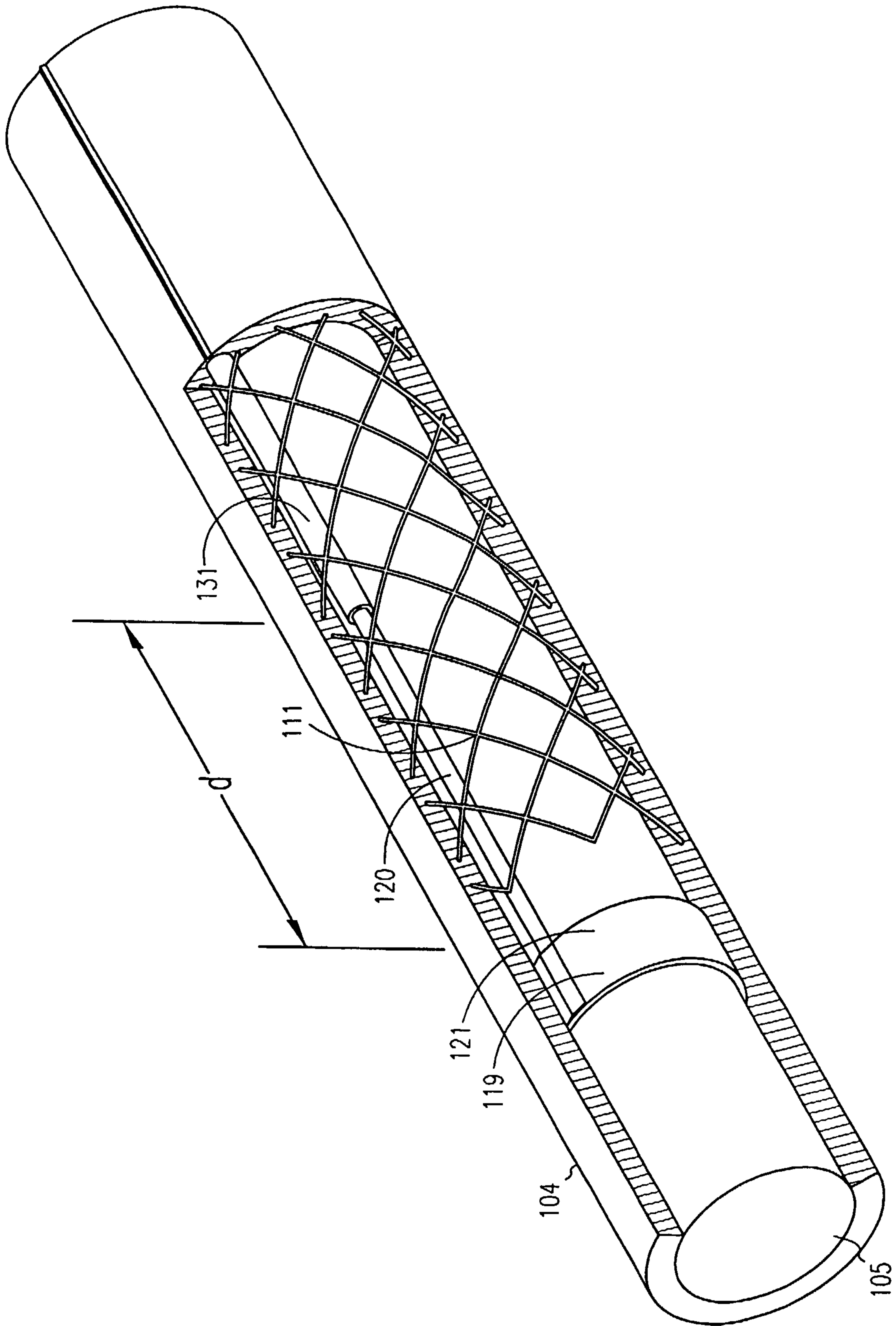

FIG. 3

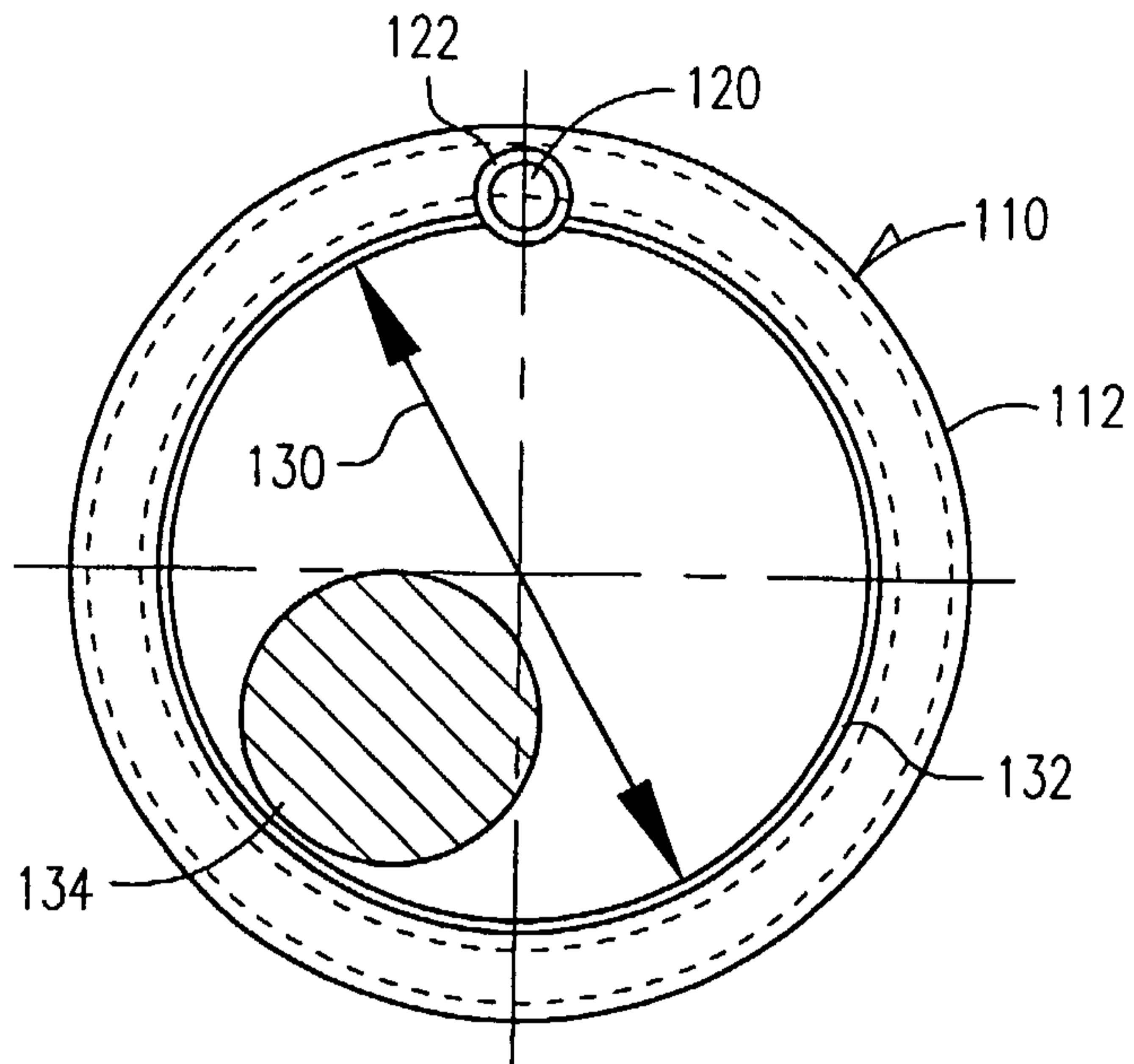

FIG. 4

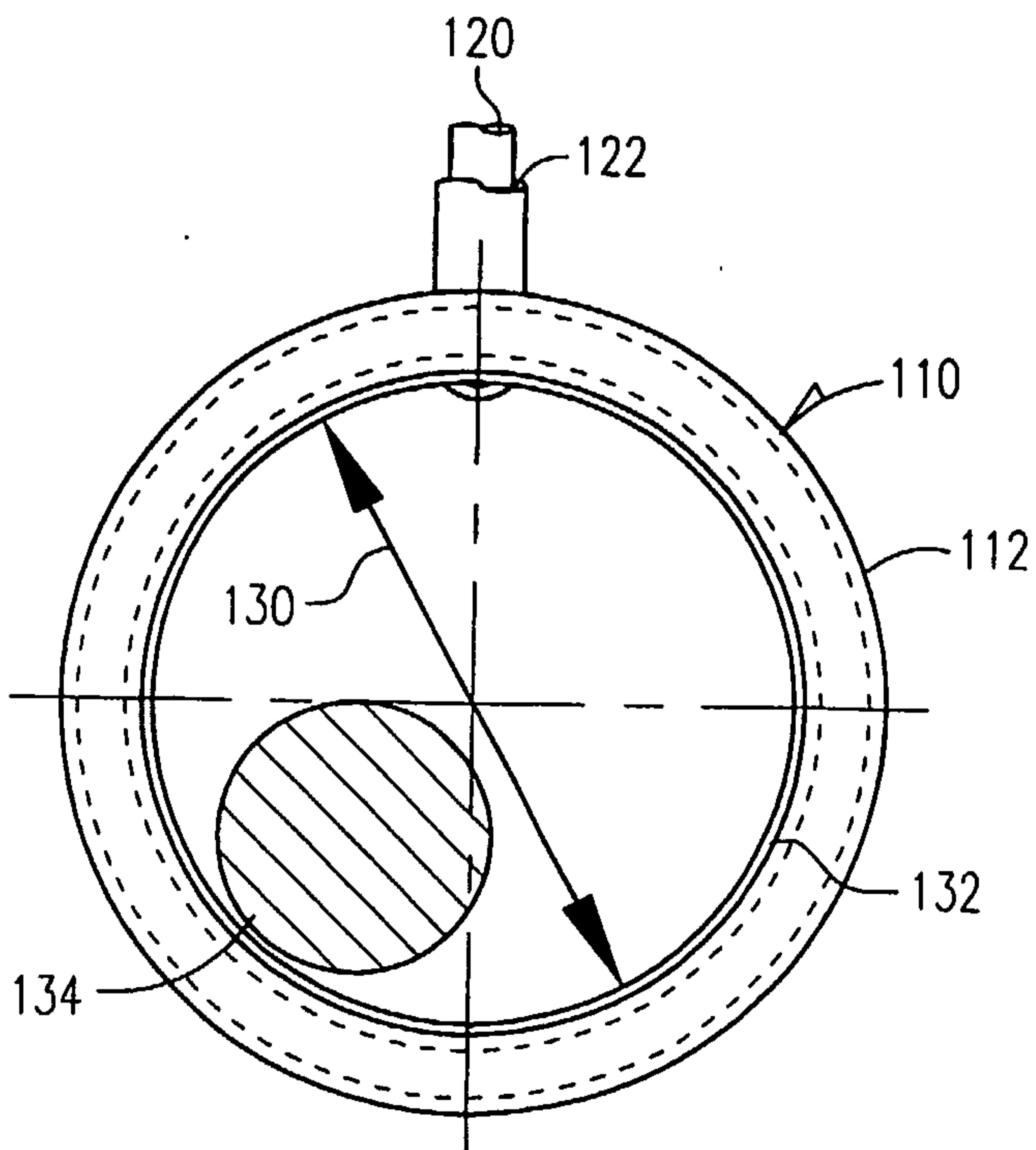

FIG. 5

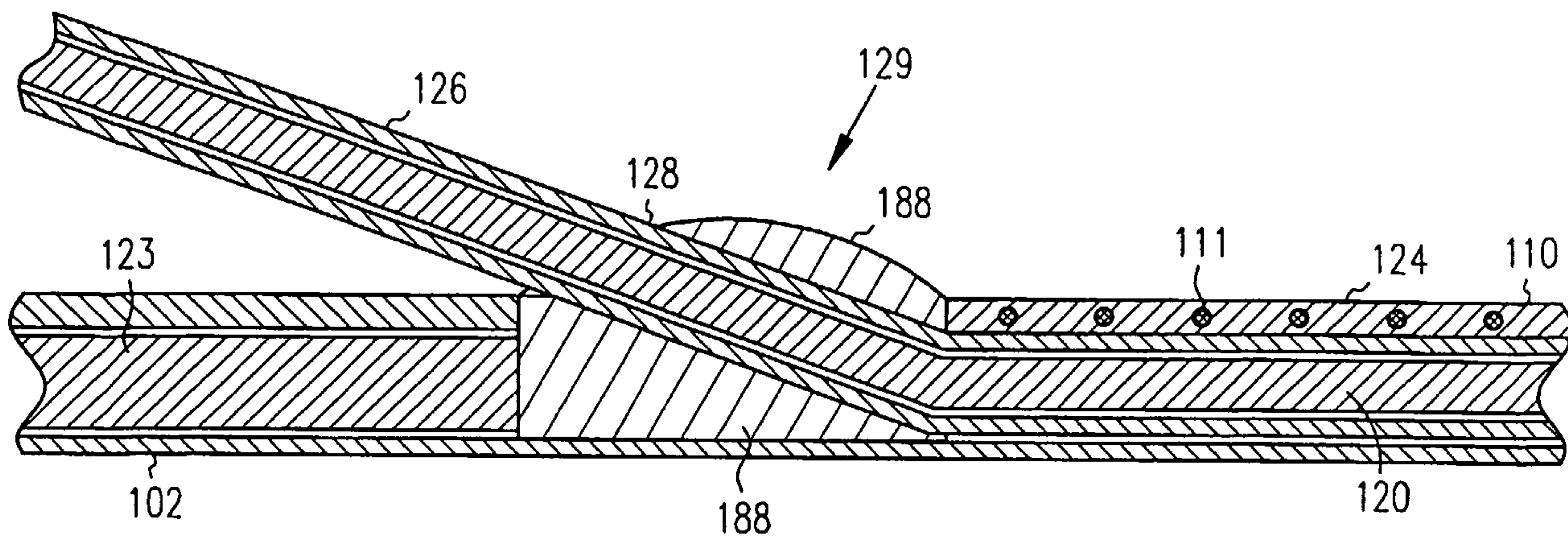

FIG. 6

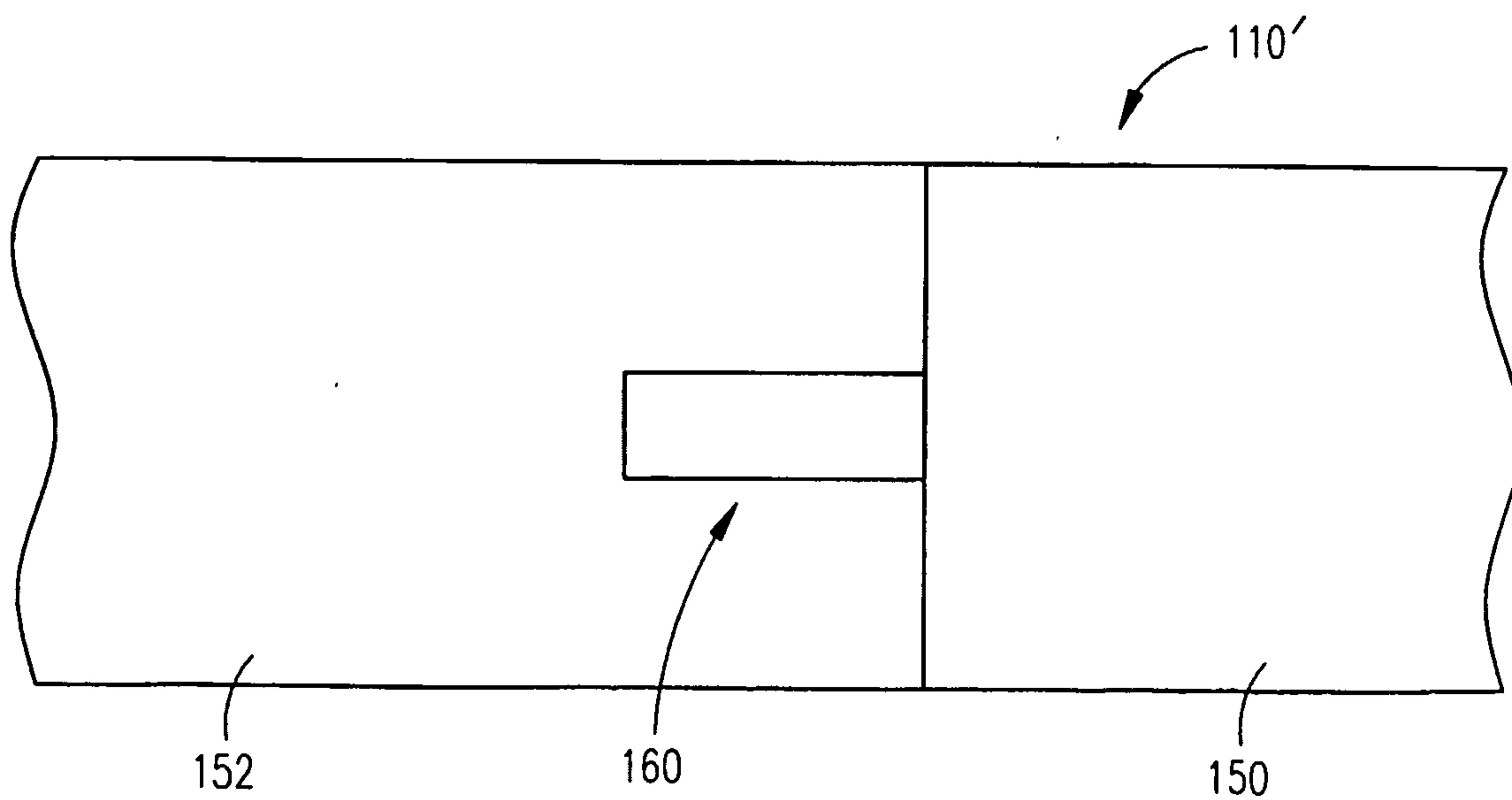

FIG. 7

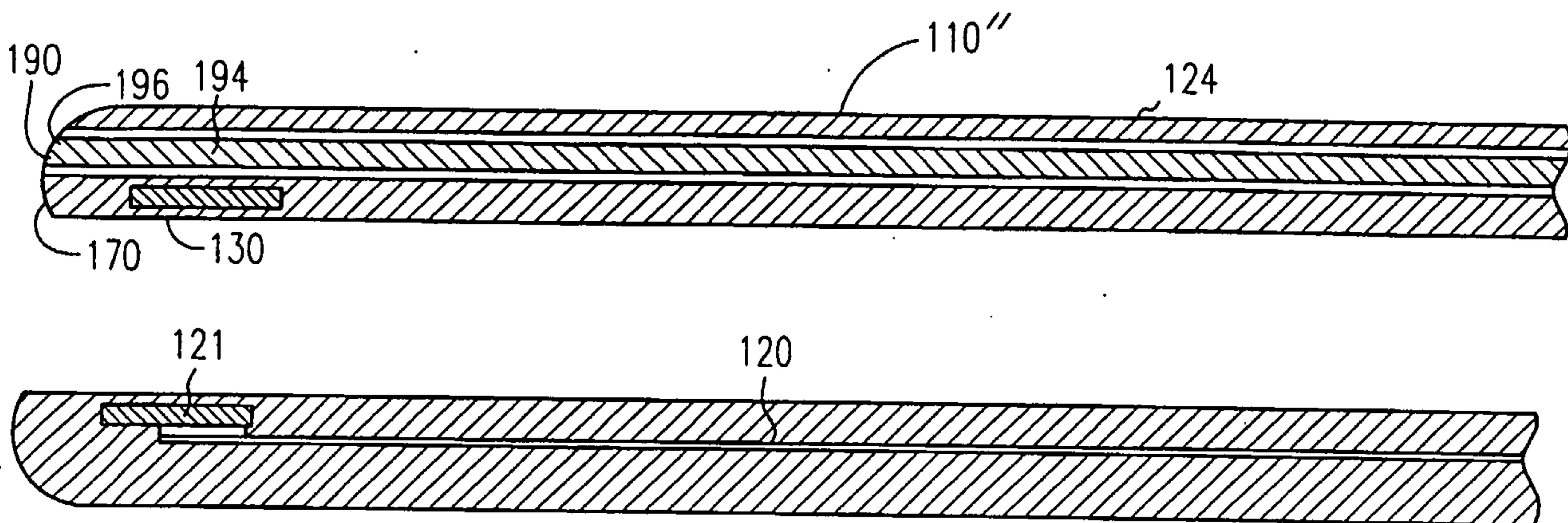

FIG. 8

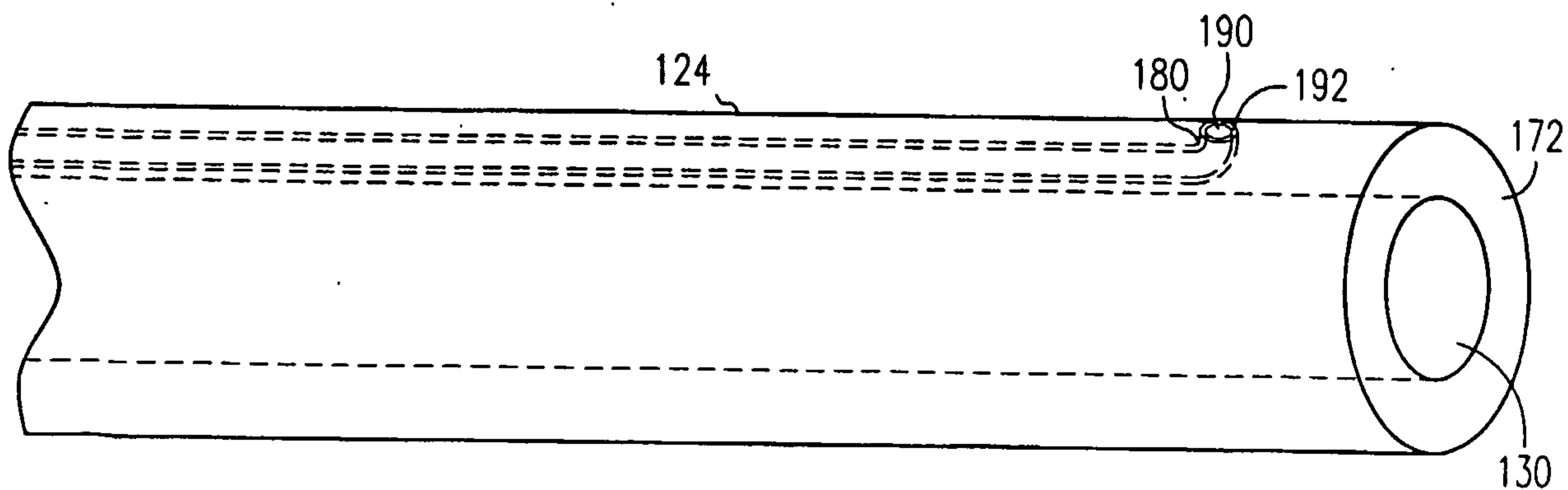

FIG. 9

