

Dec. 29, 1936.

A. LANG

2,065,813

RETRACTABLE ROLLER SCREEN

Filed Oct. 28, 1935

2 Sheets-Sheet 1

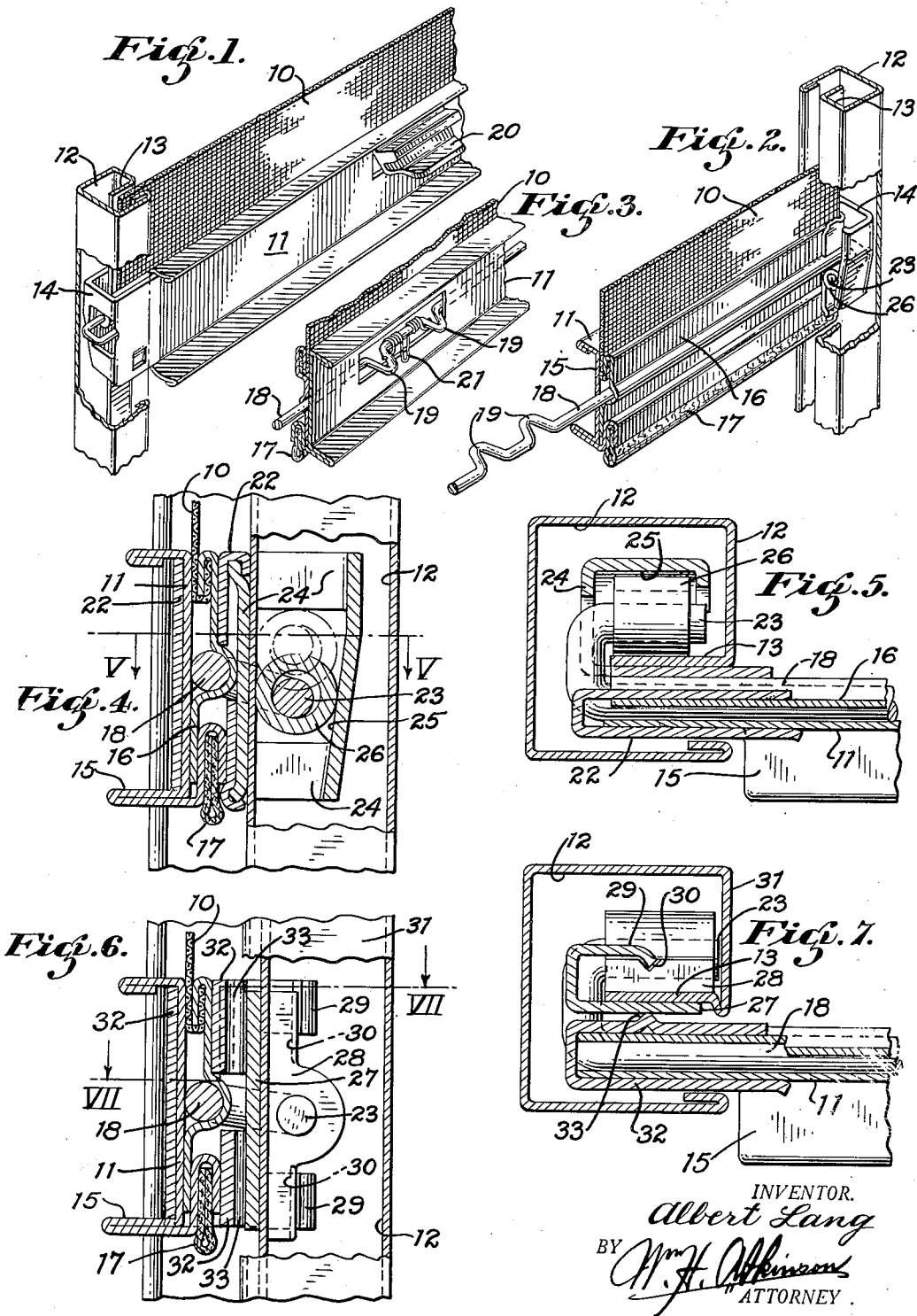

INVENTOR.
Albert Lang
BY *W. H. Robinson*
ATTORNEY.

UNITED STATES PATENT OFFICE

2,065,813

RETRACTABLE ROLLER SCREEN

Albert Lang, Berkeley, Calif.

Application October 28, 1935, Serial No. 47,003

16 Claims. (Cl. 156—39)

The present invention relates to a retractable roller screen or shade, and more particularly to a new and novel detent and guide means for a retractable roll type window screen, wherein the detent operates to hold the screen in any desired position without resort to a guide and rack having definitely spaced detent engaging projections.

An object of the invention is to provide a new and novel form of holding means for window screens of the retractable type.

Another object of the invention is to provide in a retractable window screen a new and novel guide and securing means for the free end of the screen.

Another object of the invention is to provide in combination with a retractable window screen, a new and novel form of guide and friction detent means which will be self-energizing.

In the prior art, to which the present invention relates, it has been the practice to provide a rack or spaced projections along the guide means, between which the roll screen is drawn, against which a suitable screen retaining detent may engage, to thus secure the screen in an extended position against the action of its retracting spring. With such an arrangement it will be readily seen that the screen can only be secured at the points where these projections are positioned. Therefore in order to provide for a fine adjustment in the elevation of the screen, the projections upon the rack or guides must necessarily be very closely spaced, and as a result their dimensions are limited to a relatively small size and consequently they soon wear away or become damaged, particularly at the points where the screen is most frequently secured. Therefore it is a further object of the present invention to provide a new and novel form of detent means for holding a screen in an extended position which will not require these destructible projections, and which will at the same time permit a securing of the screen at any desired point along the screen guides.

Other objects and advantages will be in part pointed out and in part evident to those skilled in the art as the description thereof proceeds.

In carrying out this invention the screen or shade is provided with a rigid draw bar at the free end thereof that is adapted at its ends to engage suitable guide means, and the guide means is provided with a friction slide or flange against one side of which the end of the draw bar is adapted to slide. Disposed at the rear of said flange, and mounted upon the end of the draw

bar, there is a self-energizing detent forming means which operates in response to gravity or spring action, as will hereinafter appear, to engage the opposite side of said friction slide or flange, and clamp the end of the draw bar thereagainst, as the screen spring exerts a retracting force thereupon. The draw bar also carries an operating rod that is connected at its ends with the detent forming means. This rod is adapted to be rotated by pressure applied upon a suitably disposed thumb rest located along the draw bar, preferably at the center. A spring bias may also be provided for the operating rod where the type of detent used requires an initial operating force to bring it into full frictional engagement with the friction slide or flange.

For a better understanding of the invention reference should be had to the accompanying drawings, wherein there is shown by way of illustration and not of limitation, several preferred embodiments thereof.

In the drawings;

Figure 1 is a fragmentary, perspective view showing a portion of a screen and guide means constructed in accordance with one embodiment of the invention,

Figure 2 is a similar view, showing the reverse side of the arrangement illustrated in Figure 1,

Figure 3 is a fragmentary, perspective view, showing a further detail of the arrangement illustrated in Figure 1,

Figure 4 is an enlarged vertical, sectional view taken through the draw bar and detent means showing details of a detent arrangement,

Figure 5 is a horizontal, sectional view taken along line V—V of Figure 4 looking in direction of arrows,

Figures 6, 8, 10 and 12 are enlarged vertical, sectional views taken through the draw bar and modified forms of detent means, and

Figures 7, 9, 11 and 13 are horizontal, sectional views taken along section indicating lines upon the figures of the drawings adjacent thereto.

Upon referring to the drawings, it will be seen that the screen structure here illustrated is in many respects similar to that disclosed in my prior Patent No. 1,990,830, issued February 12, 1935, entitled Roller screen. The present invention, and particularly the detent means herein disclosed, is in the nature of an improvement upon the arrangement illustrated in my prior patent.

As shown in Figure 1 of the drawings, the screen designated by the numeral 10 has a draw bar 11 secured across the free end thereof. The

edge of the screen 10 and the ends of the draw bar 11 are preferably disposed in channel-like guides 12, the construction of which will be described in more detail hereinafter. It will be sufficient to here state that the channel guides 12 have a reentrant flange 13 and that each end of the draw bar 11 is provided with a suitable detent supporting assembly 14 which will cooperate with the reentrant flange 13 to retain the screen 10 in an extended position against the action of a retracting spring (not shown) such as is usually provided with a roller upon which the screen 10 is rolled when retracted.

Upon referring to Figure 2 of the drawings, it will be noted that the draw bar 11 is formed by securing a channel-like front strip 15 and a back strip 16 together with the lower end of the screen 10 interlocked therebetween. The draw bar 11 thus formed also carries a rubber or felt weather strip 17 which provides for a tight seal upon the sill when the screen 10 is fully closed. Disposed between the channel-like front strip 15 and the back strip 16 of the draw bar 11 there is an operating rod 18 that is adapted to actuate the detent means, as will hereinafter appear. The detent operating rod 18 has frontwardly extending projections 19 upon which a suitable thumb rest 20 may be secured at the front of the draw bar 11, as is clearly illustrated in Figure 1 of the drawings.

In the embodiments of the present invention to be hereinafter described, resort may be had to the force of gravity acting upon the detent means to render it operative, and while the detent means will function in response to this force, in some instances it may be desirable to provide the detent operating rod 18 with a slight initial bias which will supplement the force of gravity. This is accomplished by mounting a comparatively small spring 21 between the detent operating rod 18 and the draw bar 11, as shown in Figure 3 of the drawings. Such a spring 21 will cause the detent operating rod 18 to rotate in a detent applying direction.

For a more detailed description of the above and several other embodiments of the present invention, reference will now be made to the remaining figures of the drawings in the order in which they appear.

In Figures 4 and 5 of the drawings, the draw bar 11 is shown as having a clip 22 which is bent around the ends of the front channel-like strip member 15 and the back strip 16 of the draw bar 11 so as to hold these two parts firmly together, and the detent operating rod 18 is shown as having its end 23 bent rearwardly and around the reentrant flange 13 upon the channel-like guide 12. Secured upon the end of the draw bar 11 by means of the clip 22 there is also a rearwardly disposed member 24 which has a surface 25 that is inclined at an angle with respect to the rear side of the reentrant flange 13 upon the channel-like guide 12. Arranged between the inclined surface 25 upon the member 24 and the rear side of the reentrant flange 13 there is a cylindrical detent roller 26 into which the bent end 23 of the operating rod 18 is disposed.

With this arrangement it will be seen that as the screen 10 with its draw bar 11 moves upwardly under the influence of the screen retracting spring, the cylindrical detent roller 26 will roll between the inclined surface 25 upon the member 24 and the rear side of the reentrant flange 13 and thus exert an increasing pressure upon the reentrant flange 13 until the friction

between the member 24 and the front side of the reentrant flange 13 is sufficient to overcome the action of the screen retracting spring. This will retain the screen in an extended position. Now, if it is desired to release the detent roller 25 the operator may, by exerting a downward pressure upon the thumb piece 20 at the front of the draw bar 11, rotate the detent operating rod 18 and thus lift the cylindrical detent roller 25 and hold it in an elevated position, as shown by dot and dash lines, and thus release the friction grip resulting from a rolling of the cylindrical detent roller 26 along the inclined surface 25 of the member 24, as suggested above.

In Figures 6 and 7 of the drawings, the draw bar 11, the screen assembly and the detent operating rod 18, are substantially similar to that described above. In this embodiment, instead of the detent roller 26, the detent means comprises a friction plate 27 at the front of the reentrant flange 13 and a friction shoe 28 at the rear of the reentrant flange 13. The friction shoe 28 is pivotally mounted upon the bent end 23 of the operating rod 18, and the friction plate 27 is held in cooperating relation with the friction shoe 28 by means of rearwardly bent and overhanging arms 29 carried thereby, which engage vertical grooves 30 in the back and at the ends of the friction shoe 28. With this arrangement it will be noted by an inspection of Figure 7 of the drawings, that the friction shoe 28 will be held upon the bent end 23 of the operating rod 18 by a wall 31 of the channel guide 13 and upon the reentrant flange 13 by the rearwardly projecting portion of the detent operating rod 18. Cooperating with the friction plate 27, the draw bar 11 has a securing clip 32 which is shown as provided with a vertically extending transverse ridge 33 that is adapted to engage the outside surface of the friction plate 27. This ridge 33 engages the friction plate 27 centrally of the reentrant flange 13 and permits an alignment of the friction plate 27 evenly upon the front surface of the reentrant flange 13.

From the above it might appear that the assembly of the parts in this manner would be difficult, but when consideration is given to the fact that the parts are first assembled together upon the draw bar and then moved into the guide through an open end thereof, it will be readily seen that the assembly offers no difficulties. At the same time, after the parts have been assembled in this manner, there is no possibility of their becoming disassembled or rendered inoperative. In other words, by the simple expedient of the rearwardly bent detent operating rod, the assembly is accomplished in a simple manner. In connection with this assembly, attention is drawn to the fact that the reentrant flange 13 is disposed somewhat inwardly from the edge of the channel 12 where the draw bar 11 projects there-through. This detail is not necessary to the application of the present embodiment of this invention, but such an arrangement has the advantage that it insures a clean sliding surface for the detent means, as it will not be exposed to the accumulation of paint should the channel guides 12 be painted after assembling.

With this arrangement, when the screen 10 with its draw bar 11 moves upwardly in response to any force exerted by its retracting spring, the friction shoe 28 will, by virtue of its disposition opposite the axis of rotation of the operating rod 18, grip the rear side of the reentrant flange 13 and thus, by a component of the upward force ex-

erted by the retracting spring through the screen 10, draw the friction plate 27 in frictional engagement with the front surface of the reentrant flange 13 and clamp the draw bar 11 against upward movement. This, of course, presumes a free rotation of the detent operating rod 18 due to gravity and/or a slight bias thereupon as by means of the spring 21 previously referred to in connection with Figure 3 of the drawings.

Now, if it is desired to release the screen 10, this can be accomplished by exerting downward pressure upon the thumb rest 20, which will be provided at the front of the draw bar 11, as shown in Figure 1 of the drawings. Such a rotation of the detent operating rod 18 will cause the bent end 23 thereof to move upwardly and carry the friction shoe 28 through a slight arc and out of engagement with the rear side of the reentrant flange 13 and release the pressure between the friction plate 27 and the front side of the reentrant flange 13.

In Figures 8 and 9 of the drawings, there is shown a further modification of a detent means which is adaptable for use with a screen 10 and a draw bar 11 similar to that above described. In this embodiment the draw bar 11 is formed with the detent operating rod 18 rotatably mounted between the channel-like front strip 15 and the back strip 16. The operating rod 18, as has been previously described, is provided with the rearwardly bent end 23 which extends around and in back of the reentrant flange 13 upon the channel-like guides 12. In this embodiment of the invention, the draw bar 11 is provided with a securing clip 34 at each end for securing the front and back strips 15 and 16 together at their ends. This clip 34 is also provided with turned down edges 35 at its top and bottom which engage and secure a rearwardly disposed detent supporting member 36 upon the draw bar. The detent supporting member 36 bears against the front surface of the reentrant flange 13 and at the rear thereof has a pivot forming recess 37 into which the axis of a rotatable cam 38 is disposed. As shown, the cam 38 has an eccentric outer surface 39 that engages the rear surface of the reentrant flange 13 with an increasing pressure as the draw bar 11 moves upwardly and the cam member 38, as viewed in Figure 8 of the drawings, rotates in a counterclockwise direction. The free end of the cam-like member 38 is disposed above the bent end 23 of the opening rod 18, where it will be engaged thereby when the operating rod 18 is rotated in a counterclockwise direction by the exertion of pressure upon its thumb rest 20. In order to insure a positive engagement between the cam surface 39 of the cam member 38 and the rear surface of the reentrant flange 13, the member 36 carries a leaf spring 40 which exerts a slight downward pressure upon the free end of the cam-like member 38. With this arrangement it will be seen that as the draw bar 11 is urged upwardly under the influence of the screen retracting spring, the cam-like member 38, because of its engagement with the rear side of the reentrant flange 13, will rotate in a counterclockwise direction and thus draw the friction surface of the member 36 against the front side of the reentrant flange 13 and clamp the draw bar 11 and the screen 10 securely upon the reentrant flange 13 and against movement in response to any force exerted by the screen retracting spring. Now, if it is desired to release the friction grip thus formed and raise the screen 10, this can be accomplished by applying pressure to the thumb

rest 20 and rotating the detent operating rod 18 carried by the draw bar 11. Such a rotation of the detent operating rod 18 will cause its bent end 23 to move into engagement with the cam-like member 38 and raise it against the action of the spring 40 and out of clamping engagement with the rear surface of the reentrant flange 13. The draw bar 11 and the screen can then be raised to any position desired, after which a release of the pressure upon the thumb rest 20 will permit the cam-like member 38 to again engage the reentrant flange 13 and clamp the draw bar 11 thereupon.

In Figures 10 and 11 of the drawings, there is shown an embodiment of the present invention, wherein one of the detent elements is formed integrally upon the end of the detent operating rod. In this embodiment the reentrant flange 13 upon the guide members 12 is also shown as disposed to one side of the opening in the guide channel through which the ends of the draw bar 11 extend. As here illustrated, the draw bar 11 is constructed in a manner similar to that previously described, but unlike the previously described embodiments, the detent operating rod 41 has integrally formed a rearwardly projecting cam-like extension 42 upon its ends which is adapted to engage the front surface of the adjacent reentrant flange 13. In addition to the rearwardly projecting cam-like extension 42 upon the detent operating rod 41, this embodiment has a rearwardly disposed member 43 which has a friction surface 44 that is adapted to engage the rear side of the reentrant flange 13. The member 43 may be secured upon the end of the draw bar 11 in any suitable manner. As illustrated in Figure 11 of the drawings, this member 43 is secured upon the ends of the draw bar 11 by means of an L-shaped bracket 45 which is riveted and/or spot-welded to the draw bar. In this particular arrangement the draw bar 41 is made somewhat shorter than the draw bar proper, and its bent end 23, instead of passing around the reentrant flange 13, is so disposed that it will be located substantially centrally of the reentrant flange 13 upon the guide channel 12. From an examination of Figure 11 of the drawings, it will be seen that as the draw bar 11 is urged upwardly under the influence of the screen retracting spring, the cam-like extension 42 upon the end of the draw bar 41 will roll upon and engage the front surface of the reentrant flange 13 with a constantly increasing pressure until the friction surface 44 upon the member 43 overcomes the action of the screen retracting spring. In this embodiment, like those previously described, resort may be had to the force of gravity as an actuating force upon the detent by constructing the cam-like members 42 of sufficient weight to rotate the detent operating rod 41 in a clockwise direction. If desired resort may also be had to the use of the spring 21 upon the operating rod 41, as has been previously suggested. Now, if it is desired to release the draw bar 11 and permit a raising of the screen 10, this can be accomplished by exerting pressure upon the thumb rest 20 of the draw bar 11 and rotating the detent operating rod 41 in a counterclockwise direction. This will release the pressure between the reentrant flange 13 and the surface 44 upon the member 43 and permit the screen to be freely moved up or down.

In Figures 12 and 13 of the drawings, there is shown another embodiment of the invention which is in many respects similar to that illustrated in Figures 4 and 5 of the drawings. In this latter

embodiment, however, instead of the cylindrical detent forming roller 26 there is provided a wedge-like member 46. As here shown, the draw bar 11 has a clip 47 which is adapted to secure the front and back strips 15 and 16 of the draw bar 11 together and at the same time this clip 47 supports a rearwardly disposed wedge supporting member 48 into which the wedge 46 may be disposed. The member 48 has an inclined surface 49 against which one side of the wedge 46 is adapted to operate. The other side of the wedge 46 engages the rear side of the reentrant flange 13 so that when an upward movement is imparted to the draw bar 11, the wedge 46 will become wedged between the rear of the reentrant flange 13 and the surface 49 upon the member 48 and thus secure the screen 10 and the draw bar 11 against further upward movement. To provide for a control of the wedge 46 by means of the operating rod 18, the wedge 46 is provided with an opening 50 into which the bent end 23 of the operating rod 18 is disposed. With this arrangement it will be seen that when the operating rod 18 is free to move under the influence of gravity and/or the spring 21, should the latter be provided, the wedge 46 will become tightly wedged against the rear surface of the reentrant flange 13 where it will hold the screen, as suggested above. Now, if it is desired to release the wedge 46 and permit an upward movement of the screen 10, this can be accomplished by applying pressure to the thumb rest 20 upon the draw bar 11 and rotating the operating rod 18 in a counterclockwise direction. This rotation of the operating rod 18 will lift the wedge 46 and thus release the friction grip upon the reentrant flange 13 provided thereby.

From the above description it will be seen that the present invention provides a detent means for a spring retractable screen or shade which is adapted to hold the screen in any desired position between its limits of movement. It will also be noted that the detent means herein provided entirely dispenses with the use of ratchet engaging projections and/or any such rack-like arrangement which may become destroyed by constant use. It will also be noted that when the detent means provided by this invention is released, the screen and its draw bar may be moved up or down between the limits of its travel in a silent manner. That is, without the usual racking noise such as exists where the detent requires a series of ratchet receiving projections upon the guide means.

A further advantage of the present invention which will be obvious after a consideration of the several constructions illustrated and described, is that the draw bar with its detent means serves to center the screen between and substantially free of the guide channels except when the detent means is in operation to secure the screen against movement.

While I have, for the sake of clearness and in order to disclose the invention so that the same can be readily understood, described and illustrated specific devices and arrangements, I desire to have it understood that this invention is not limited to the specific means disclosed, but may be embodied in other ways that will suggest themselves to persons skilled in the art. It is believed that this invention is new and it is desired to claim it so that all such changes as come within the scope of the appended claims are to be considered as part of this invention.

Having thus described my invention, what I claim and desire to secure by Letters Patent is—

1. In an improved roll screen, the combination

of a draw bar secured across the free end of a retractable screen for moving same, a guide extending along a side of said screen, said guide having a vertically extending flange against one side of which an end of said draw bar is adapted to slide, a detent member supported upon said end of the draw bar and frictionally engaging the opposite side of said vertically extending flange, and an operating rod extending across said draw bar with an end bent into operating relation with said friction detent member.

2. In an improved roll screen, the combination of a draw bar secured across the free end of a retractable screen for moving same, a guide extending along a side of said screen, said guide having a vertically extending smooth flange against one side of which an end of said draw bar is adapted to slide, a detent member operable in response to a retracting movement of the screen supported upon said end of the draw bar and frictionally engaging the opposite side of said smooth flange, and an operating rod mounted upon said draw bar with its end bent into operating relation with said friction detent member for rendering said detent member inoperative to permit a retraction of the screen.

3. In an improved roll screen, the combination of a draw bar secured across the free end of a retractable screen for moving same, a guide extending along a side of said screen into which the end of said draw bar extends, said guide having a vertically extending two-sided flange against one side of which the end of said draw bar is adapted to slide, a rearwardly disposed friction detent member supported at the end of said draw bar and engaging the opposite side of said two-sided flange, and an operating rod extending across and rotatably mounted upon said draw bar with its end connected in operating relation with said friction detent member.

4. In an improved roll screen, the combination of a rigid draw bar secured across the free end of a retractable roll screen, a guide disposed at the side of said screen along which it is adapted to be drawn, said guide having a slide forming flange along one side of which said draw bar is adapted to slide, a detent supporting member attached to the end of said draw bar and extending around to the other side of said slide forming flange, and a gravity responsive detent carried by said detent supporting member engaging the rear side of said slide forming flange and operable in response to an upward movement of said draw bar to frictionally engage said slide forming flange and clamp said draw bar thereagainst and hold said screen in an extended position.

5. The combination set forth in claim 4, wherein the detent supporting member has a surface spaced from and inclined with respect to said slide forming flange and the gravity responsive detent consists of a roller element disposed between the inclined surface upon the detent supporting member and said slide forming flange.

6. The combination set forth in claim 4, wherein the detent supporting member has a surface spaced from and inclined with respect to said slide forming flange and the gravity responsive detent consists of a wedge-like member disposed between the inclined surface upon the detent supporting member and said slide forming flange.

7. In an improved roll screen, the combination of a rigid draw bar secured across the free end of a retractable roll screen, a channel-like guide disposed along a side of said screen along which

the screen is adapted to be drawn, said channel-like guide having a reentrant flange disposed substantially centrally thereof along one side of which said draw bar is adapted to slide, a detent supporting member attached at the end of said draw bar and extending around said reentrant flange, and a detent carried by said detent supporting member engaging the other side of said reentrant flange, said detent being operable in response to an upward movement of said draw bar to frictionally engage said reentrant flange and clamp said draw bar thereagainst and hold said screen in an extended position.

8. In an improved roll screen, the combination of a draw bar secured across the free end of a retractable roll screen for extending same, a detent operating rod rotatably mounted upon said draw bar, a guide disposed along a side of said screen over which one end of said draw bar is adapted to be drawn, said guide having a flange disposed in a plane parallel with the screen against one side of which an end of said draw bar will slide when the screen is extended thereby, and detent means engaging the other side of said flange operating in response to upward movement of and cooperating with said draw bar to grip said flange and hold the screen in an extended position.

9. The combination set forth in claim 8, wherein the detent means consists of an eccentric cam-like member which upon slight rotation will exert a pressure upon said flange and clamp the draw bar thereagainst.

10. The combination set forth in claim 8, wherein the detent means consists of a right angle extension on the detent operating rod having a flange engaging surface which is eccentric to the axis of said detent operating rod.

11. In an improved roll screen, the combination of a draw bar secured across the free end of a retractable roll screen for extending same, a guide disposed along a side of said screen along which it is adapted to be drawn, said guide having a smooth reentrant flange upon which said end of the draw bar will slide when the screen is extended thereby, a detent operating rod rotatably mounted upon said draw bar and having its end bent around the reentrant flange upon said spaced guide, and detent means upon the end of said detent operating rod engaging the other side of said reentrant flange and operating in response to an upward movement of the draw bar to grip said flange and hold the screen in an extended position.

12. An improved guide for roll screens of the character described, comprising a channel-like member having four sides with an opening extending throughout its length in one side thereof

into which the end of a screen draw bar may project, and a reentrant flange disposed intermediate the four sides of the channel-like member throughout its length by bending a free edge thereof upon itself for a short distance and then outwardly into the space surrounded by the four walls of the member.

13. In an improved roll screen, the combination of a guide for a retractable screen having a flange forming a grip surface for a clamping detent, a draw bar at the free end of a retractable screen for drawing the screen along said guide, a rod extending along and rotatably mounted upon said draw bar, and a self-energizing gripping detent disposed at the end of said draw bar adapted to grip the flange upon said guide as the retractable screen exerts a pull thereupon.

14. In an improved roll screen, the combination of a guide for a retractable screen having a flange forming a grip surface for a clamping detent, a draw bar at the end of the retractable screen adapted to slide along said guide, a rod extending along and rotatably mounted upon said draw bar, a self-energizing gripping means upon an end of said draw bar adapted to grip said flange as the screen exerts a pulling force upon said draw bar, and a connection between said rod and said gripping means whereby said gripping means may be released by rotation of said rod.

15. In an improved roll screen, the combination of a guide strip having a front and back friction surface disposed along the path of movement of a retractable screen, a draw bar at the free end of the retractable screen for moving same along said guide strip, a rotatable rod secured upon said draw bar having its ends extending around said guide strip, a friction plate disposed between the end of said draw bar and the front friction surface of said guide strip, and a friction shoe upon the end of said operating rod engaging the back friction surface of said guide strip.

16. In an improved roll screen of the character described, the combination of a draw bar at the free end of a retractable screen, a friction surface forming member disposed along a side of said screen having its opposite surfaces exposed to the gripping action of a detent means, an operating rod rotatably mounted upon said draw bar, a friction gripping means having opposed members disposed one against each side of said friction surface forming member, the opposed members of said friction gripping means being secured upon said draw bar and held in cooperating relation with the opposite surfaces of said friction surface forming member by bending the end of said rod around and in back of said friction surface forming member.

ALBERT LANG.