

1

2a 2e

3a

3b 3c

4

5 ,

<

1 :

12 :

13 :

21 :

31 :

34 :

34a, 34b : 1, 2

34c :

(modified Golay code)

가 가

가 , 가
가 가 .

Signal to Noise Ratio) (transducer) 가 가 (Sign (Pulse Compressio

(transducer) 가 가 (correlator) (convolution)

가

가

가

가

1

가 , 1

1

가

1

2

가 , 2

2

가

2

(1) , 가 128 가
 (aperture) 64

(31) (Pre - Amp), 가
 TGC (Time Gain Compensation,) -

(35) (36)

(41) (envelope detection), (log compression) B -

(42) B -

가 (main lobe) 가 (side lobe) 가

2 2a 2b 가 2
 2c 2d 2e 2c 2d
 a_i b_i 가 n +1 -1 가

1

$$c_j = \sum_{i=1}^{i=n-j} a_i a_{i+j}$$

$$d_j = \sum_{i=1}^{i=n-j} b_i b_{i+j}$$

가

2

$$c_j + d_j = 0; \quad j \neq 0$$

$$c_j + d_j = 2n$$

가

FIR 가 (Window) (side

$$g_{am}(t) * g_{am}(-t) + g_{bm}(t) * g_{bm}(-t) = \text{ramp}(t/2T) * m(t) * m(-t)$$

5

$$\text{ramp}(t/2T) = \begin{cases} \frac{t}{T} + 1, & -T \leq t \leq 0 \\ -\frac{t}{T} + 1, & 0 < t \leq T \end{cases}$$

가

6

$$g_{am}(t) * g_a(-t) + g_{bm}(t) * g_b(-t) = \text{ramp}(t/2T) * m(t)$$

(bipolar pulser)

가
DAC가

가

가

3b

3c 3b

4

(beamforming)

RF

가
(Near field)

가

4

(Modified Golay code)

(correlator)

4 (12)

(13)

(Bipolar Pulser)

가

(14)

(12)

(13)

1

(14)

4

(13)

(14)가

가

(1)

가

(g_{am})

(g_{bm})

1 ,

(sidelobe)

가

(34)가

(31) RF 1 RF (34a)
(correlator, 34c)

가

4 가

(34c) (31) (autocorrelation)

2 RF (34b)

가

4

1

2

가

가 1

RF 가
가

가

(34c)

가 가 (35)

(35)

(36)

(41)

(42)

(B -)

가

가

가

4

가 가
가

5a 5c

)

(5a

5b

5b 5c

SNR 4dB

가

가

RF

(57)

1.

가 , 1

1 가 1 가 , 1

2 가 , 2

2 가 2 가 ,

1 2 가 ,

가 ,

2.

1 (bi - phase window)

3.

2 (bi - phase rectangular window), (biphase hamming window), (bi - phase hanning window) (bi - phase bartlett win dow)

4.

1 , 1 2 1 2 1 2

10.

9 , , 1 ,

11.

6 , 1 2

12.

6 , 2 , 1 1
 , 2 2

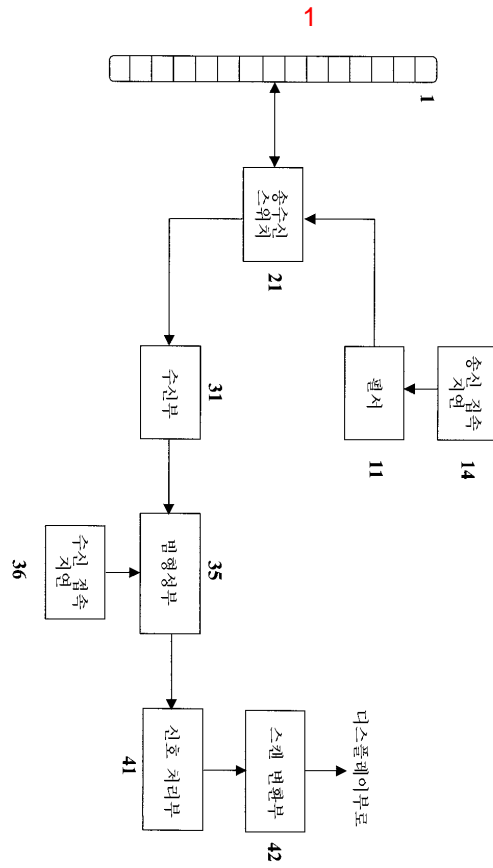

2

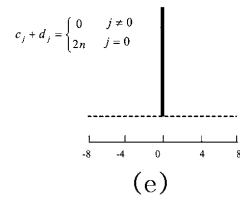
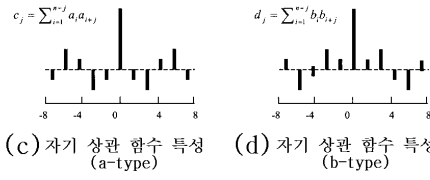
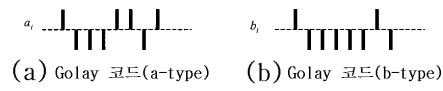

3a

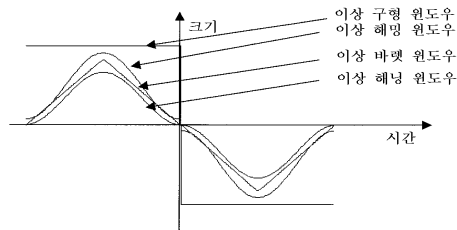

3b

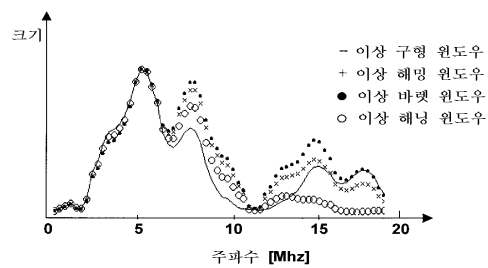

3c

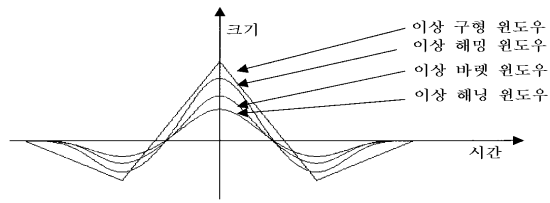

4

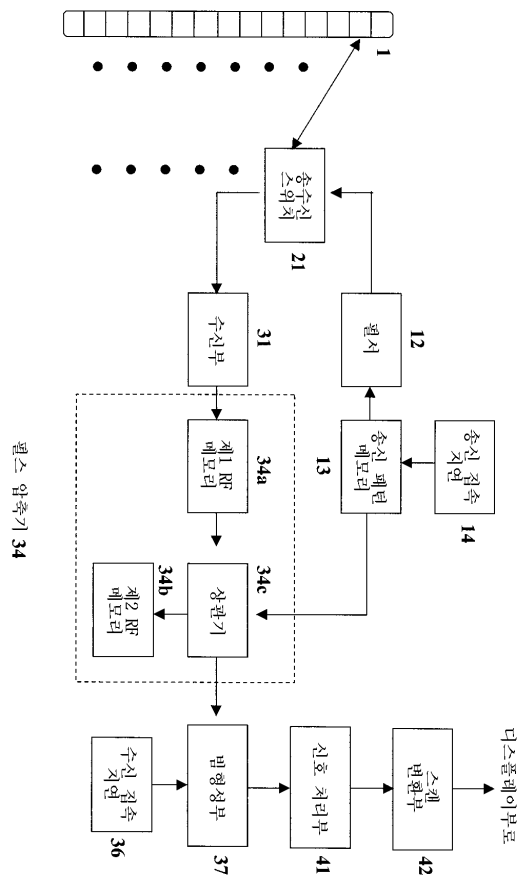

5a

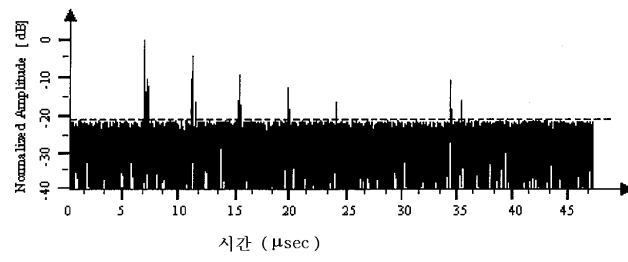

5b

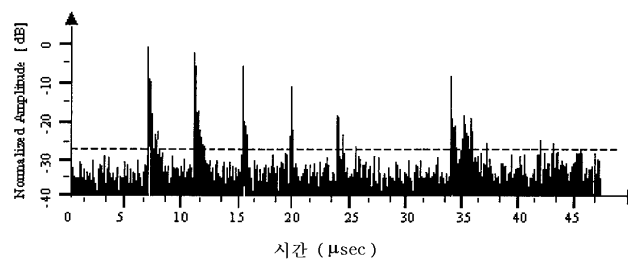

5c

