

(19) World Intellectual Property Organization  
International Bureau



(43) International Publication Date  
30 August 2007 (30.08.2007)

PCT

(10) International Publication Number  
**WO 2007/098324 A2**

(51) International Patent Classification:  
A61F 2/44 (2006.01)

(21) International Application Number:  
PCT/US2007/061972

(22) International Filing Date:  
12 February 2007 (12.02.2007)

(25) Filing Language: English

(26) Publication Language: English

(30) Priority Data:  
11/307,681 16 February 2006 (16.02.2006) US

(71) Applicant (for all designated States except US): AMED-ICA CORPORATION [US/US]; 614 Arapeen Drive, Suite 302, Salt Lake City, UT 84108 (US).

(72) Inventor: BERNERO, John, P.; 8324 Campeche Bay Place, Round Rock, TX 78681 (US).

(74) Agents: LOWRY, Stuart, O. et al.; Kelly Lowry & Kelley, LLP, 6320 Canoga Avenue, Suite 1650, Woodland Hills, CA 91367 (US).

(81) Designated States (unless otherwise indicated, for every kind of national protection available): AE, AG, AL, AM, AT, AU, AZ, BA, BB, BG, BR, BW, BY, BZ, CA, CH, CN, CO, CR, CU, CZ, DE, DK, DM, DZ, EC, EE, EG, ES, FI, GB, GD, GE, GH, GM, GT, HN, HR, HU, ID, IL, IN, IS, JP, KE, KG, KM, KN, KP, KR, KZ, LA, LC, LK, LR, LS, LT, LU, LV, LY, MA, MD, MG, MK, MN, MW, MX, MY, MZ, NA, NG, NI, NO, NZ, OM, PG, PH, PL, PT, RO, RS, RU, SC, SD, SE, SG, SK, SL, SM, SV, SY, TJ, TM, TN, TR, TT, TZ, UA, UG, US, UZ, VC, VN, ZA, ZM, ZW.

(84) Designated States (unless otherwise indicated, for every kind of regional protection available): ARIPO (BW, GH, GM, KE, LS, MW, MZ, NA, SD, SL, SZ, TZ, UG, ZM, ZW), Eurasian (AM, AZ, BY, KG, KZ, MD, RU, TJ, TM), European (AT, BE, BG, CH, CY, CZ, DE, DK, EE, ES, FI, FR, GB, GR, HU, IE, IS, IT, LT, LU, LV, MC, NL, PL, PT, RO, SE, SI, SK, TR), OAPI (BF, BJ, CF, CG, CI, CM, GA, GN, GQ, GW, ML, MR, NE, SN, TD, TG).

Published:  
— without international search report and to be republished upon receipt of that report

For two-letter codes and other abbreviations, refer to the "Guidance Notes on Codes and Abbreviations" appearing at the beginning of each regular issue of the PCT Gazette.

(54) Title: SPINAL IMPLANT WITH ELLIPTICAL ARTICULATORY INTERFACE

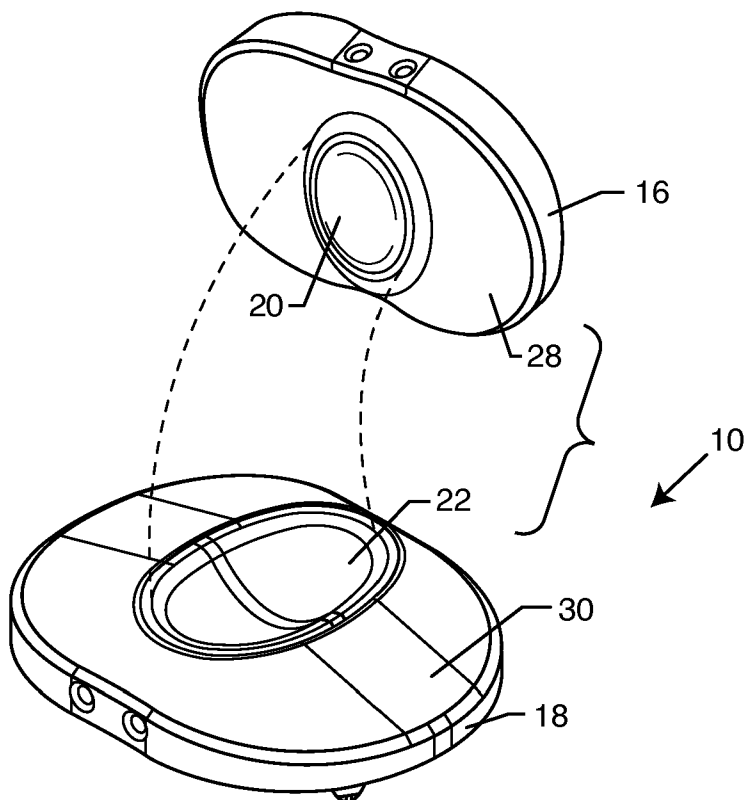

(57) Abstract: A spinal implant prosthesis includes a pair of end plates for affixation to adjacent vertebral bone structures and respectively defining inter-engaged convex and concave articulatory surfaces of elliptical profile. These elliptical articulatory surfaces are elongated in an anterior-posterior direction, and are comparatively shorter in a medial-lateral direction. With this configuration, in response to angular displacement and/or axial rotation, the elliptical surfaces displace in a manner increasing the distance between the adjacent vertebral bone structures, thereby tensioning the prosthesis and producing counteracting forces which urge the components back toward a substantially centered or neutral position. In addition, in the preferred form, the anterior-posterior length of the concave articulatory surface is incrementally greater than the anterior-posterior length of the convex articulatory surface to accommodate a limited range of anterior-posterior translation.

WO 2007/098324 A2

## SPINAL IMPLANT WITH ELLIPTICAL ARTICULATORY INTERFACE

### DESCRIPTION

#### BACKGROUND OF THE INVENTION

[Para 1] This invention relates generally to improvements in spinal implants of the type designed for human implantation between adjacent spinal vertebrae. More particularly, this invention relates to an improved spinal implant prosthesis including a pair of implant components defining inter-engaged articulatory surfaces having a generally elliptical profile shape and designed to accommodate limited and/or controlled articulatory movement.

[Para 2] Spinal implant devices are generally known in the art for surgical implantation between adjacent bony vertebral structures to correct or alleviate a number of clinical problems, such as degenerative disc disease, chronic back pain, spondylolisthesis, and others. In general terms, such spinal implants comprise a biocompatible construct formed from a relative high strength material such as titanium or cobalt chrome metal alloy, or a selected high strength ceramic, with a size and shape for intervertebral placement. In some designs, the implant has a porous region or regions adapted to receive autogenous or allogeneous bone material, or otherwise defining a so-called porous bone ingrowth surface, for promoting bone ingrowth attachment of the implant device to the adjacent overlying and underlying vertebral structures. Such spinal implants are commonly

used as fusion devices forming a substantially rigid interface between adjacent vertebral structures for alleviating specific patient symptoms. Alternative spinal implant designs comprise articulatory devices including upper and lower components adapted for respective fixation to overlying and underlying vertebral structures while defining an articulatory interface therebetween to maintain or restore normal or substantially normal patient movements.

[Para 3] A variety of articulatory spinal implant devices are known in the art. By way of example, U.S. Patent 5,401,269 discloses one articulatory implant device having inter-engaged concave and convex surfaces defined by curved radial or part-circular arches, wherein the radius of the curved arches is greater in the anterior-posterior direction relative to a smaller arch radius in the medial-lateral direction. These different sizes of the inter-engaged arches in the anterior-posterior vs. medial-lateral directions beneficially accommodates a limited range of axial rotation between the articulatory surfaces, while producing counteracting forces that tend to return the engaged surfaces toward a normal neutral or non-rotated position. In addition, the engaged arched surfaces further accommodate a range of angular displacement. However, such angular displacement, *e.g.*, in the anterior-posterior direction, or in the medial-lateral direction, is not accompanied by a counteracting or re-centering force tending to urge the engaged surfaces back toward a normal neutral position. Physical stops are provided to prevent excessive angular displacement between the implant components.

[Para 4] U.S. Patent 6,113,637 discloses another articulatory spinal implant device having inter-engaged concave and convex surfaces of generally part-

spherical or hemi-spherical shape, with the concave surface further including a centrally located cylindrical segment. This articulatory interface is designed to accommodate substantially unrestrained angular displacement as well as axial rotation between the engaged implant components, while additionally and beneficially permitting a range of fore-aft or anterior-posterior translation. Counteracting forces tending to resist over-displacement and tending to re-center the articulatory surfaces substantially in a neutral position are not present.

[Para 5] There exists a need for further improvements in and to articulatory spinal implant devices, particularly wherein a range of angular displacement and/or axial rotation between engaged articulatory surfaces is accompanied by counteracting forces urging return movement of the engaged surfaces substantially to an initial or neutral position, and further wherein the engaged articulatory surfaces accommodate a range of anterior-posterior displacement. The present invention fulfills these needs and provides further related advantages.

#### **SUMMARY OF THE INVENTION**

[Para 6] In accordance with the invention, a spinal implant prosthesis defines an inter-engaged pair of concave and convex articulatory surfaces of elliptical profile shape, wherein these articulatory surfaces are elongated in the anterior-posterior direction and are comparatively shorter in the medial-lateral direction. In the preferred form, the anterior-posterior length of the concave surface is greater than the anterior-posterior length of the convex surface by a selected increment. These articulatory surfaces accommodate a limited range of anterior-

posterior translation therebetween, and further accommodate a range of relative angular displacement and/or axial rotation while applying a corresponding counteracting or re-centering force urging the implant components back toward a substantially centered or neutral position.

[Para 7] In the preferred form, the spinal implant comprises a pair of end plates, such as upper and lower end plates, formed from a suitable biocompatible construct and including affixation means for secure attachment respectively to adjacent overlying and underlying vertebral bone structures, as by means of fixation pins, bone cement, porous bone ingrowth surfaces, or a combination thereof. These end plates respectively define the inter-engaged convex and concave articular surfaces of elliptical profile. In one form, the upper end plate carries the convex articular surface for nested reception into and articular engagement with the concave surface carried by the lower end plate.

[Para 8] Each of the articular surfaces is defined by the substantially elliptical profile shape which is longer in the anterior-posterior direction and shorter in the medial-lateral direction. More particularly, in the anterior-posterior profile, the convex articular surface has an elongated shape defined by a major axis extending generally in the anterior-posterior direction and sized for nested reception into the concave articular surface which has an incrementally longer size and shape, *i.e.*, an incrementally longer major axis also extending generally in the anterior-posterior direction. In the medial-lateral direction, the convex and concave articular surfaces define comparatively smaller elliptical profiles, *i.e.*,

comparatively smaller major axes which extend generally in the medial–lateral direction, and may be of substantially uniform size.

[Para 9] In use, the inter–engaged convex and concave articulatory surfaces of elliptical profile accommodate a range of relative angular displacement and relative axial rotation therebetween. However, as the two end plates are angularly displaced and/or axially rotated, the convex elliptical surface rides against the concave elliptical surface in a manner increasing the distance between the adjacent vertebral bone structures, thereby tensioning the prosthesis and producing a counteracting force or forces urging the components back toward a substantially centered or neutral position. In addition, the anterior–posterior size differential between the convex and concave articulatory surfaces accommodates a limited range of anterior–posterior translation therebetween.

[Para 10] Other features and advantages of the invention will become more apparent from the following detailed description, taken in conjunction with the accompanying drawings which illustrate, by way of example, the principles of the invention.

#### **BRIEF DESCRIPTION OF THE DRAWINGS**

[Para 11] The accompanying drawings illustrate the invention. In such drawings:

[Para 12] FIGURE 1 is an exploded anterior or front perspective view of the spinal implant with elliptical articulatory interface embodying the novel features of the invention;

[Para 13] FIGURE 2 is an exploded anterior–posterior vertical sectional view of the spinal implant of FIG. 1;

[Para 14] FIGURE 3 is an anterior–posterior vertical sectional view similar to FIG. 2, but illustrating upper and lower components of the spinal implant in articulatory engagement;

[Para 15] FIGURE 4 is an exploded medial–lateral vertical sectional view of the spinal implant of FIG. 1; and

[Para 16] FIGURE 5 is a medial–lateral vertical sectional view similar to FIG. 4, but showing the upper and lower implant components in articulatory engagement.

#### DETAILED DESCRIPTION OF THE PREFERRED EMBODIMENT

[Para 17] As shown in the exemplary drawings, a spinal implant referred to generally in FIGURES 1–5 by the reference numeral 10 is provided for surgical implantation into the intervertebral space between a pair of adjacent vertebral bone structures 12 and 14. The spinal implant 10 includes an upper component 16 and a lower component 18 adapted for respective affixation to the adjacent vertebral structures 12 and 14. The upper and lower components 16, 18 of the spinal implant 10 define inter-engaged convex and concave articulatory surfaces 20 and 22 of generally elliptical profile shape. These engaged articulatory surfaces 20, 22 are shaped to accommodate a limited range of angular displacement and/or axial rotation while producing a counteracting force or forces urging the components back toward a substantially centered or neutral position.

In addition, the engaged articulatory surfaces 20, 22 accommodate a limited range of translation in an anterior-posterior direction.

[Para 18] The articulatory spinal implant device 10 of the present invention includes the upper and lower implant components 16 and 18 formed from a suitable biocompatible material with a size and shape for respective engagement with and secure affixation to the overlying and underlying adjacent bony vertebral structures 12 and 14. In this regard, the bone-facing surfaces of the two implant components 16, 18 may include projecting fins, teeth or pins 24 or the like designed to provide immediate stable anchored engagement with the adjoining vertebral structures. The two implant components 16, 18 may also include respective upper and lower surfaces 26 defined by or otherwise suitably coated with a porous bone ingrowth structure or substance to permit and accommodate relatively rapid bone ingrowth and osteo-integration for long term stable affixation to the adjoining vertebral structures.

[Para 19] The upper and lower implant components 16, 18 of the articulatory device 10 further define mutually facing bearing surfaces that are geometrically shaped for articulatory interengagement with each other in a manner intended to preserve and/or accommodate substantially normal anatomical intervertebral motion. The illustrative drawings show the upper implant component 16 to include an underside surface 28 in surrounding relation to the generally convex and centrally located articulatory surface or bearing member 20 protruding downwardly therefrom. This downwardly protruding convex articulatory surface 20 is received and movably supporting within the upwardly presented recessed or



concave articulatory surface or bearing member 22 formed generally centrally within an upper surface 30 on the lower implant component 14.

[Para 20] In accordance with the invention, the inter-engaged convex and concave articulatory surfaces 20 and 22 are both formed with a generally elliptical profile shape. More particularly, both articulatory surfaces 20, 22 are shaped to define a generally elongated elliptical profile in the anterior-posterior direction, and a comparatively smaller elliptical profile in the medial-lateral direction. Accordingly, as viewed best in FIG. 1, the convex articulatory surface 20 is thus shaped to define a generally football-shaped structure extending downwardly from the surrounding underside surface 28 of the upper component 16, for movable seated reception into the upwardly presented concave articulatory surface 22 of generally football-shape formed generally centrally within the upper surface 30 of the lower component 18.

[Para 21] The generally elliptical profile shape of the convex and concave articulatory surfaces 20, 22 in the anterior-posterior profile is shown best in FIGS. 2-3. As shown, the upper convex articulatory surface 20 is formed generally as a partial surface of an ellipse 100 having a major axis "A" extending generally in an anterior-posterior direction. This convex articulatory surface 20 seats within the upwardly presented concave articulatory surface 22 which is also formed generally as a partial surface of an ellipse 200 having a major axis "AA" having a dimension at least slightly larger than the dimension of the major axis "A" of the ellipse 100.

[Para 22] FIGS. 4-5 show the elliptical profile shapes of the convex and concave articulatory surfaces 20, 22 in the medial-lateral profile. As shown, the upper

convex articular surface 20 in the medial-lateral profile is formed generally as a partial surface of an ellipse 300 having a major axis "B" extending generally in the medial-lateral direction. The lower concave articular surface 22 is also formed generally as a partial surface of an ellipse 400 having a major axis "BB" with a dimension which may match or be substantially identical to the major axis "B" of the ellipse 300.

[Para 23] Accordingly, the upper convex articular surface 20 comprises a downwardly bulging structure having a shape corresponding generally to a segment of an ellipsoid defining the elongated major axis "A" extending generally in the anterior-posterior direction, and a shorter axis "B" extending generally in the medial-lateral direction. This convex ellipsoid structure 20 seats within the lower concave articular surface 22 comprising a recessed structure having a shape corresponding generally to a segment of an ellipsoid defining by the elongated major axis "AA" in the anterior-posterior direction, and the shorter axis "BB" extending generally in the medial-lateral direction. As noted, the major axis "AA" of the concave articular surface 22 is longer than the major axis "A" of the convex articular surface, whereas the shorter axes "BB" and "B" in the medial-lateral direction are substantially equal.

[Para 24] With this construction, when the convex and concave articular surfaces 20, 22 are engaged, controlled and relative movement is accommodated. Specifically, the size differential in the anterior-posterior direction permits a short increment of anterior-posterior translation between the upper and lower implant components 16, 18. In one preferred form, the size differential in the anterior-

posterior direction is on the order of about ½ to about 3 millimeters, thereby permitting substantially unrestrained anterior–posterior translation within a range of about ½ to about 3 millimeters. However, as such translation approaches the limit, the anterior or posterior end of the convex elliptical surface 20 rides against the concave elliptical surface 22 to resist further displacement therebetween. That is, as the convex elliptical surface 20 rides up on the concave elliptical surface 22, the distance between the adjacent vertebral structures 12, 14 is increased, resulting in tensioning of the prosthetic joint to produce a counteracting force which resists further displacement and effectively urges the articular surfaces 20, 22 back toward a substantially centered or neutral position.

[Para 25] The same phenomenon occurs in response to relative angular displacement or relative axial rotation, or a combination thereof, between the two articular surfaces 20, 22. That is, the elliptical profile shape of the convex articular surface 20 rides against the elliptical profile shape of the concave articular surface 22, thereby urging the upper and lower components 16, 18 apart and thereby also increasing the spacing between the adjoining vertebral structures 12, 14. This results in tensioning of the prosthetic joint, to produce a counteracting force or forces that resists further displacement and effectively urges the articular surfaces 20, 22 back toward a substantially centered or neutral position.

[Para 26] FIGS. 3 and 5 show the convex articular surface 20 protruding downwardly from the upper component 16 a sufficient distance to maintain the surrounding underside surface 28 of the upper component 16 in spaced relation to

the upper surface 30 of the lower component 18, when the convex surface 20 is seated in articulatory bearing engagement with the concave surface 22. In this regard, this inter-component spacing is desirably sufficient to maintain the component surfaces 28, 30 in spaced relation throughout a normal range of relative angular displacement on the order of about 5 to about 40 degrees, and preferably on the order of about 25 degrees.

[Para 27] A variety of further modifications and improvements in and to the improved articulatory spinal implant of the present invention will be apparent to those persons skilled in the art. By way of limited example, it will be understood that the upper convex and lower concave articulatory surfaces 20, 22 may be reversed, if desired. In addition, persons skilled in the art will appreciate that the anterior-posterior length of the concave surface 22 may be increased, relative to the convex surface, by incorporating a centrally located cylindrical segment within the otherwise elliptical profile shape of the concave surface 22. Accordingly, no limitation on the invention is intended by way of the foregoing description and accompanying drawings, except as set forth in the appended claims.

**What is claimed is:**

- [Claim 1] A spinal implant, comprising:  
a pair of implant components adapted for affixation respectively to adjacent vertebral structures and including inter-engageable articulatory bearing members; said bearing members including a convex articulatory surface and a concave articulatory surface both defined by a generally elliptical profile shape in an anterior-posterior direction and a generally elliptical profile shape in a medial-lateral direction.
- [Claim 2] The spinal implant of claim 1 wherein said concave articulatory surface is incrementally elongated relative to said convex articulatory surface in the anterior-posterior direction.
- [Claim 3] The spinal implant of claim 2 wherein said concave articulatory surface substantially matches said convex articulatory surface in the medial-lateral direction.
- [Claim 4] The spinal implant of claim 1 wherein said convex and concave articulatory surfaces are each formed as a segment of an ellipsoid.
- [Claim 5] The spinal implant of claim 1 wherein said convex and concave surfaces are elongated in the anterior-posterior direction relative to the medial-lateral direction.
- [Claim 6] The spinal implant of claim 1 wherein said pair of implant components each include means for affixation to adjacent vertebral structures.
- [Claim 7] A spinal implant, comprising:

a pair of implant components adapted for affixation respectively to adjacent vertebral structures and including inter-engageable articulatory bearing members; said bearing members respectively including convex and concave articulatory surfaces each defined by a generally elliptical profile shape in an anterior-posterior direction and a generally elliptical profile shape in a medial-lateral direction;

said convex and concave surfaces being elongated in the anterior-posterior direction relative to the medial-lateral direction; and

said concave articulatory surface being incrementally elongated relative to said convex articulatory surface in the anterior-posterior direction, and substantially matching each other in the medial-lateral direction.

**[Claim 8]** A spinal implant, comprising:

a pair of implant components adapted for affixation respectively to adjacent vertebral structures and including inter-engageable articulatory bearing members; said bearing members respectively including convex and concave articulatory surfaces of generally ellipsoid shape having an elongated major axis extending generally in an anterior-posterior direction; and

said concave articulatory surface being incrementally elongated relative to said convex articulatory surface in the anterior-posterior direction.

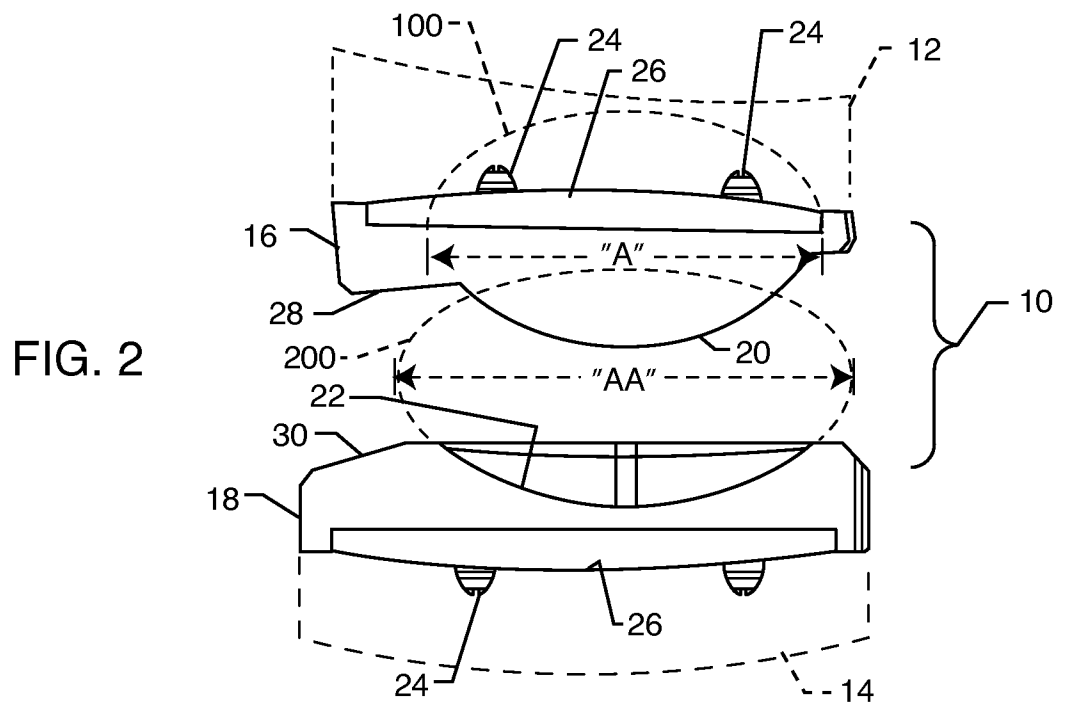
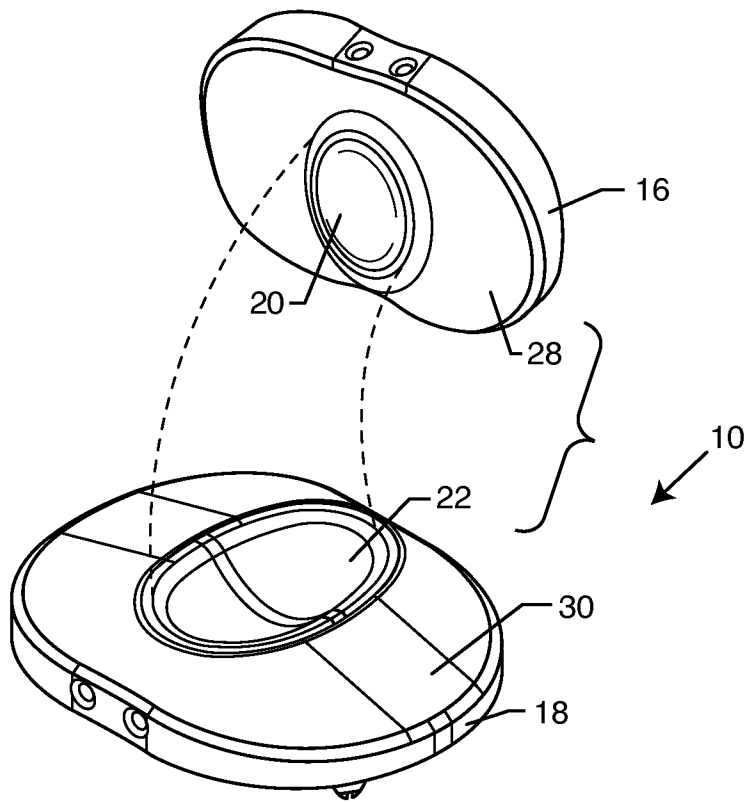

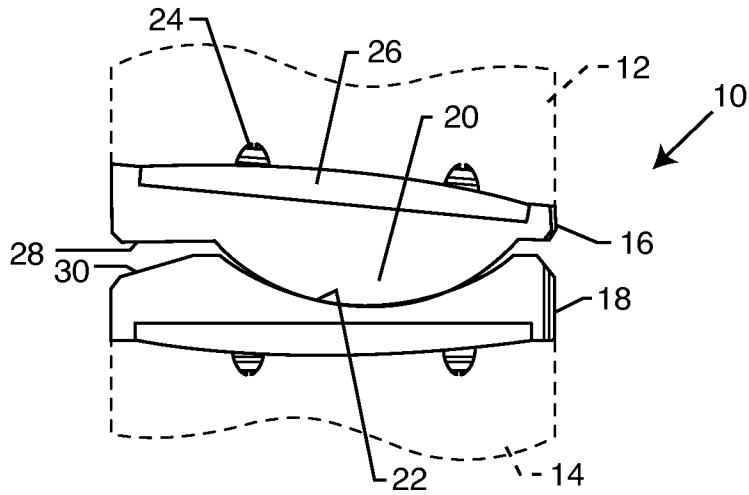

FIG. 3

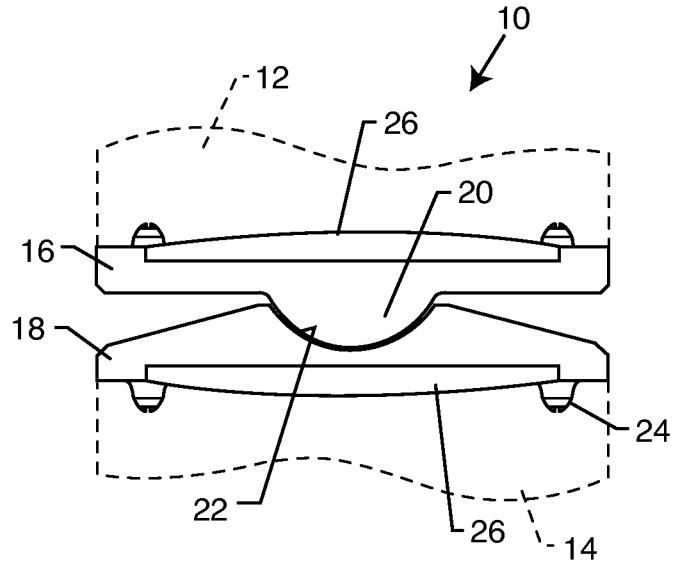

FIG. 5

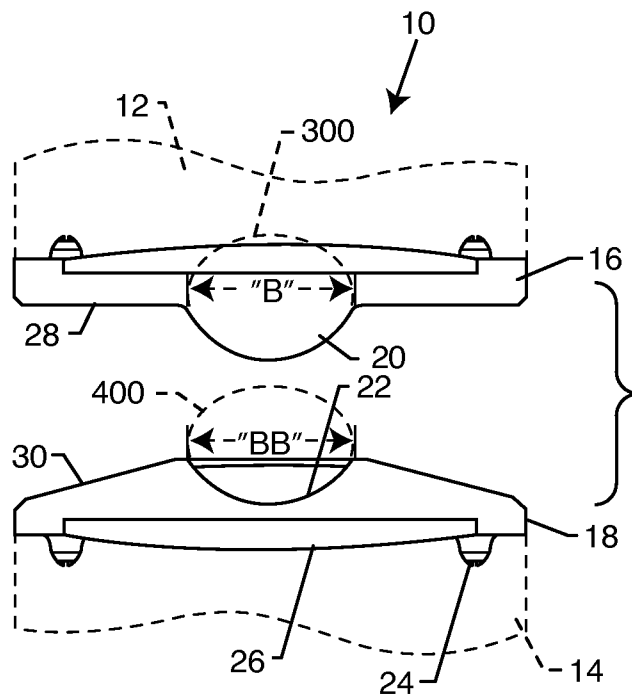

FIG. 4