



(19) **United States**

(12) **Patent Application Publication**  
**Heo**

(10) **Pub. No.: US 2002/0018416 A1**

(43) **Pub. Date: Feb. 14, 2002**

(54) **DVD-AUDIO DISK, AND APPARATUS AND METHOD FOR RECORDING DATA ON AND/OR REPRODUCING DATA FROM THE SAME**

(30) **Foreign Application Priority Data**

Mar. 25, 1997 (KR) ..... 10330/1997  
Oct. 9, 1997 (KR) ..... 51861/1997

(75) Inventor: **Jung-Kwon Heo, Seoul (KR)**

**Publication Classification**

(51) **Int. Cl.<sup>7</sup> ..... G11B 7/005**  
(52) **U.S. Cl. .... 369/47.35**

Correspondence Address:  
**STAAS & HALSEY LLP**  
**700 11TH STREET, NW**  
**SUITE 500**  
**WASHINGTON, DC 20001 (US)**

(57) **ABSTRACT**

A DVD-Audio which includes a data zone for storing data to be reproduced and an information zone for storing information on the data to be reproduced. The information zone includes directories of a video title set (VIDEO TS) and an audio title set (AUDIO\_TS). The AUDIO\_TS directory includes information on an audio manager (AMG) having information on audio titles. The data zone includes the audio titles each having an audio title set information (ATSI) followed by a plurality of contiguous audio objects (AOBs). The ATSI includes a plurality of audio stream attributes each having an audio coding mode, first to third quantization bit numbers, first to third sampling frequencies and decoding algorithm information relating to the number of audio channels. Each of the AOBs includes a plurality of audio packs recorded with audio data corresponding to the decoding algorithm stored in the audio stream attribute.

(73) Assignee: **Samsung Electronics Co., Ltd., Suwon-city (KR)**

(21) Appl. No.: **09/908,622**

(22) Filed: **Jul. 20, 2001**

**Related U.S. Application Data**

(60) Division of application No. 09/047,363, filed on Mar. 25, 1998, which is a continuation-in-part of application No. 08/921,082, filed on Aug. 29, 1997, now abandoned.

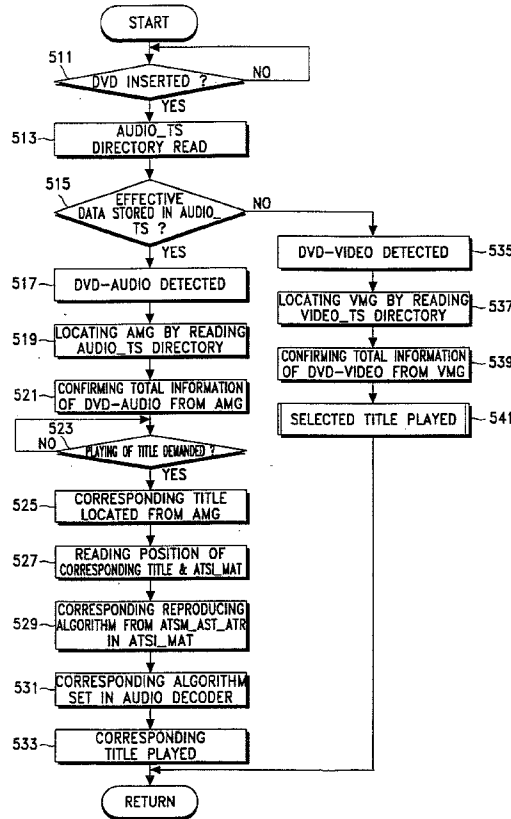

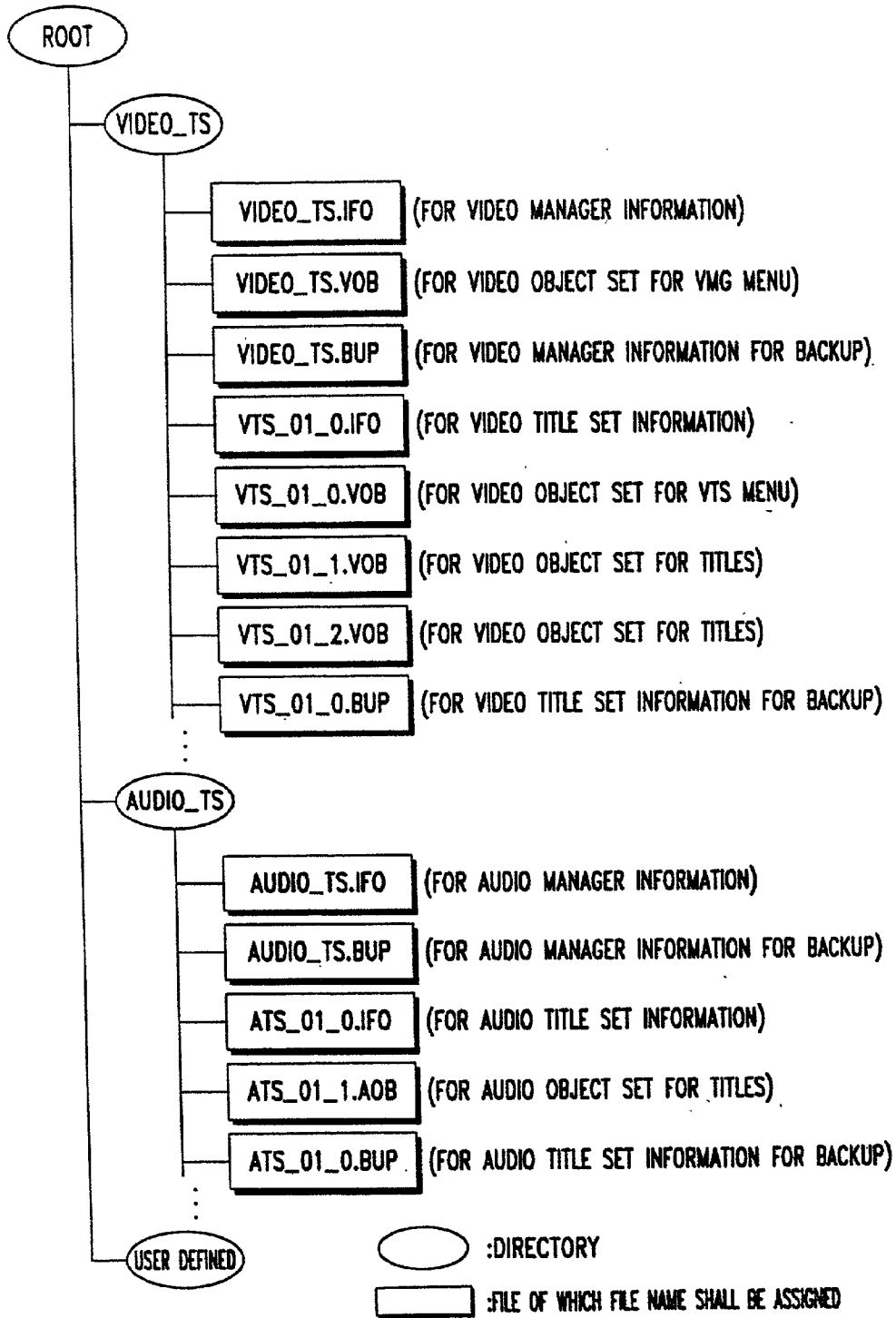

FIG. 1

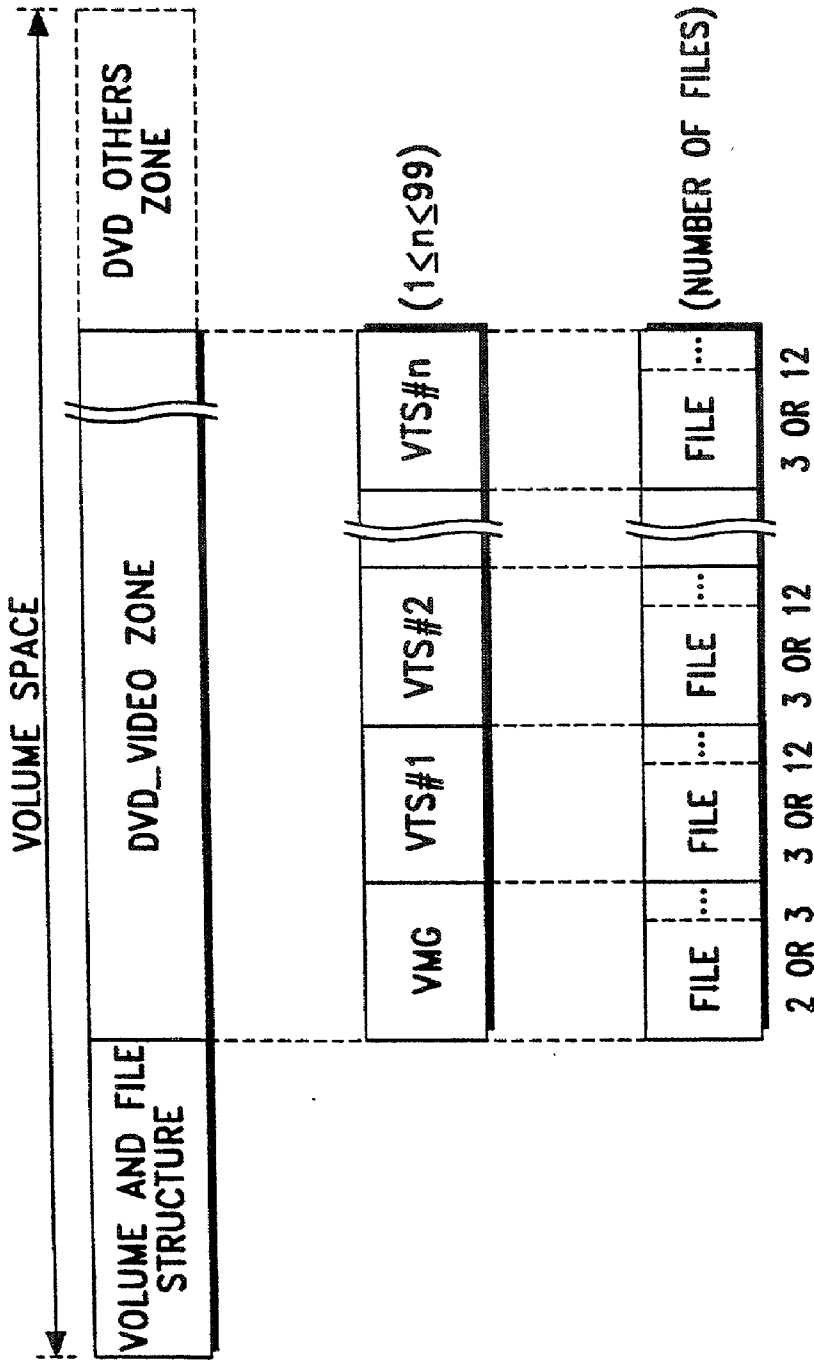

FIG. 2

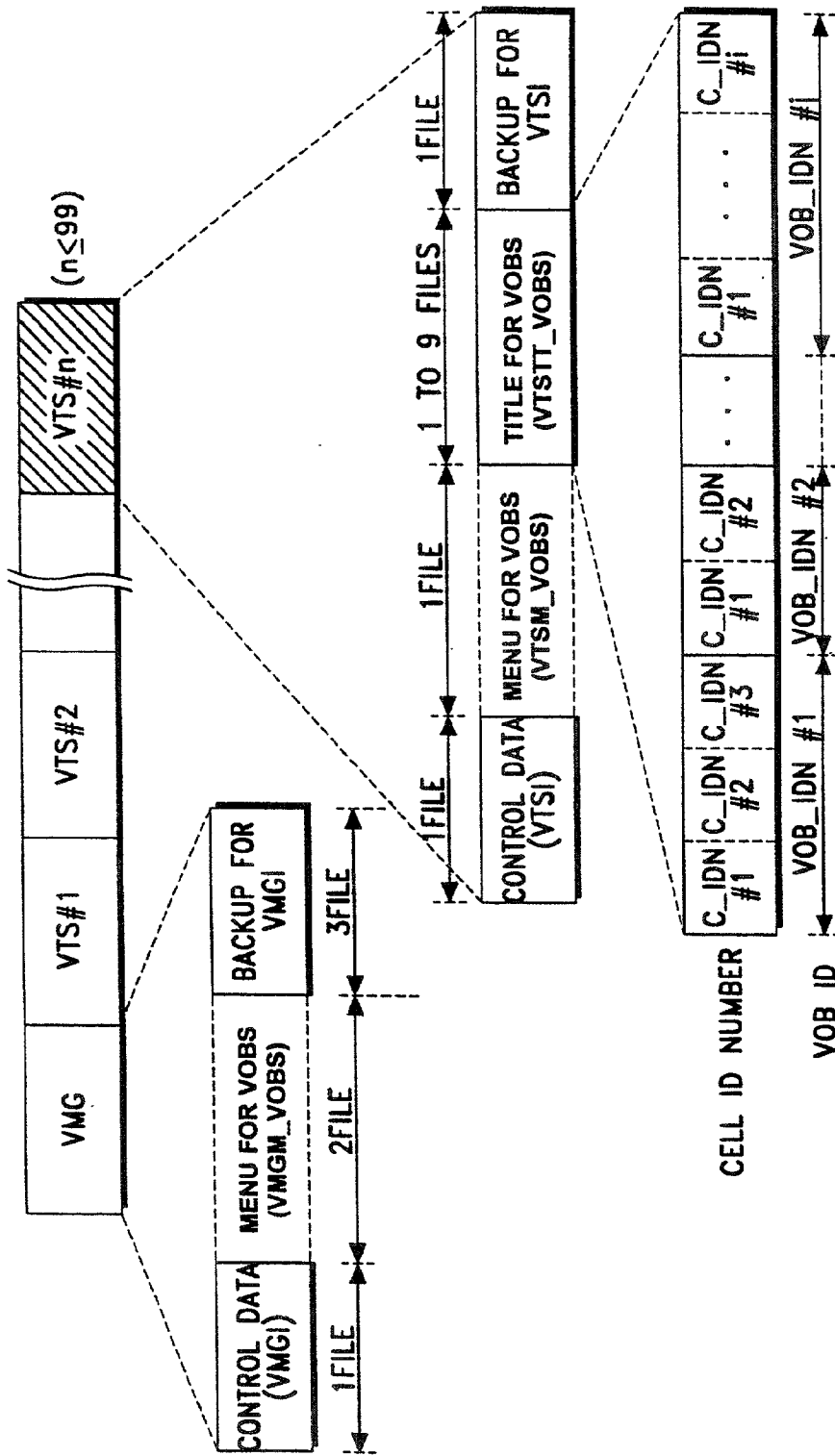

FIG. 3

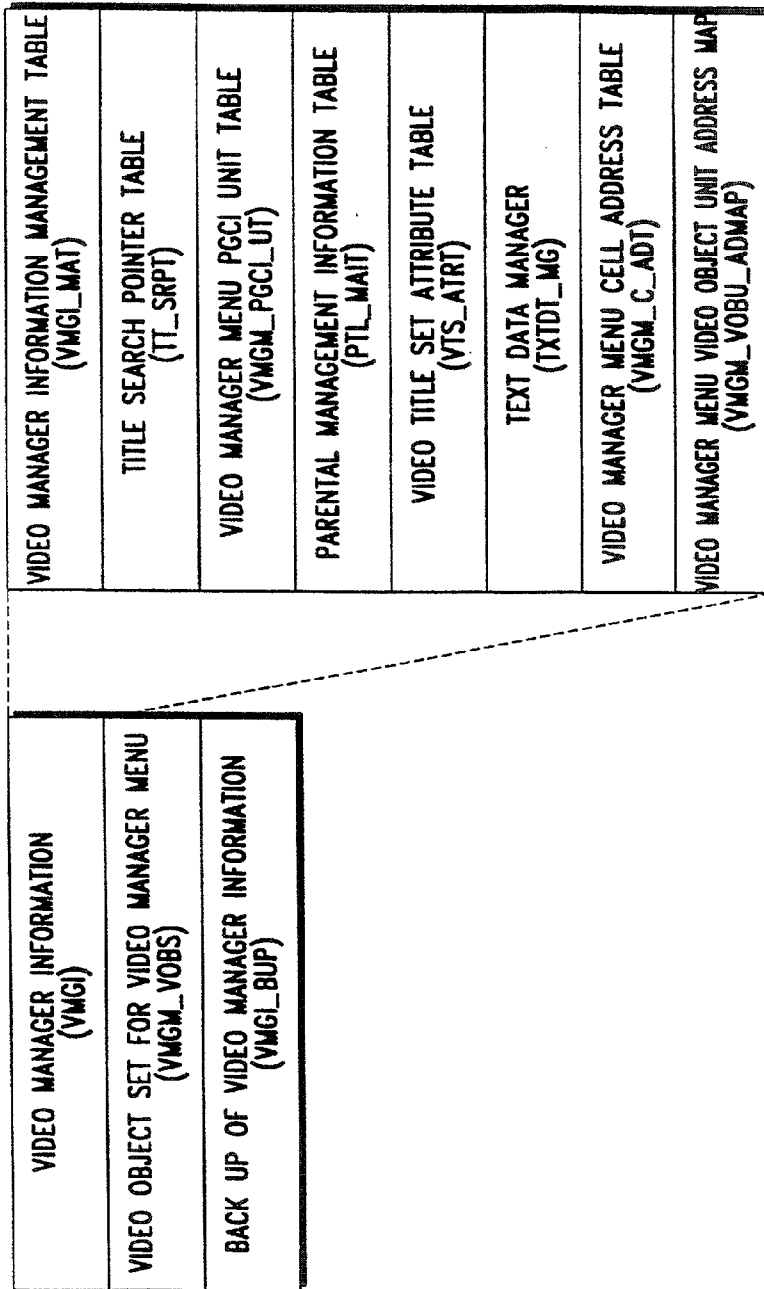

FIG. 4

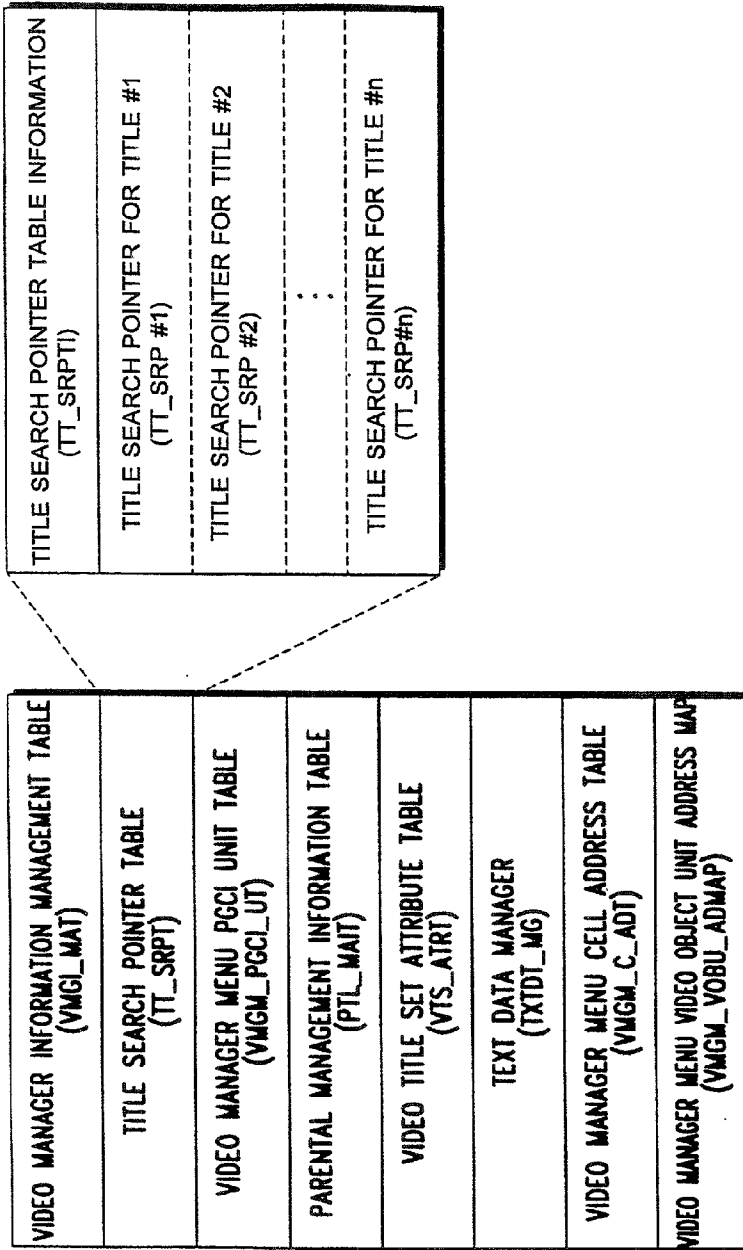

FIG. 5

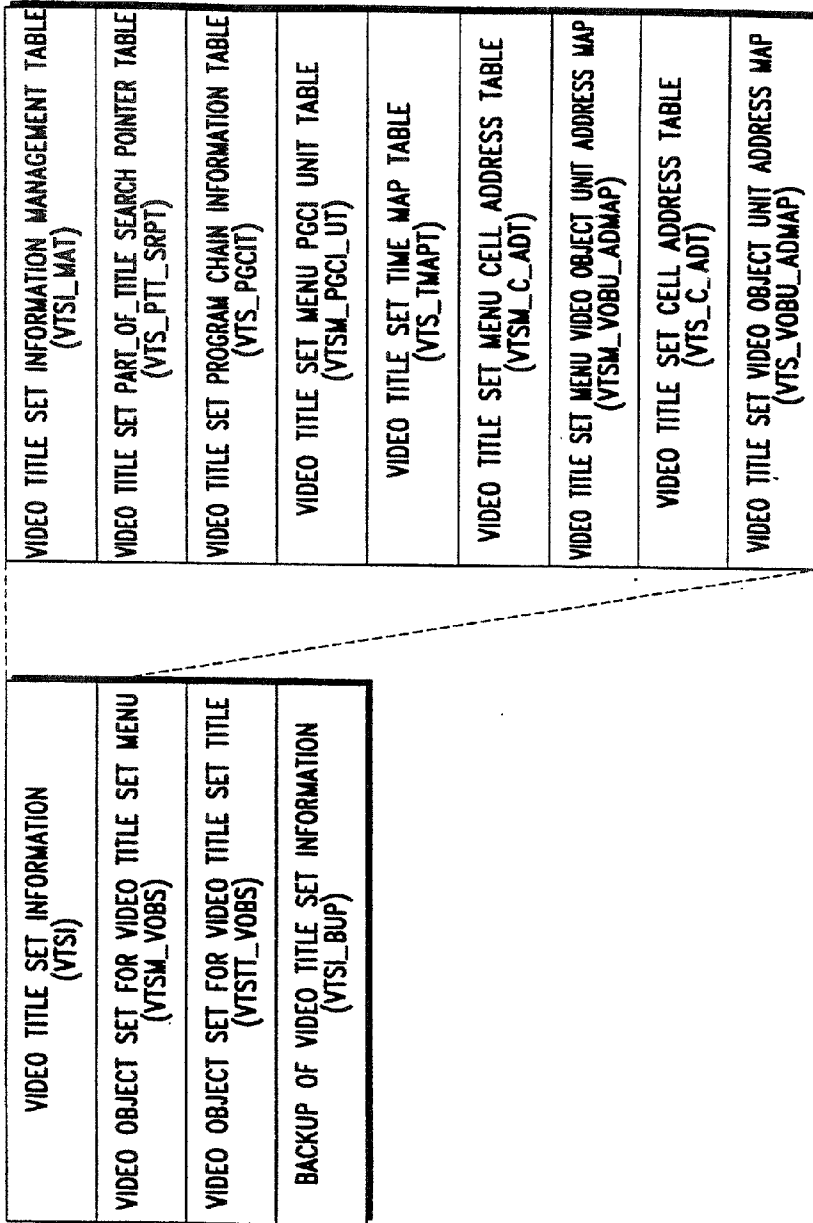

FIG. 6

VTSI\_MAT

RBP		CONTENTS	NUMBER OF BYTES
0 TO 11	VTS_ID	VTS IDENTIFIER	12BYTES
12 TO 15	VTS_EA	END ADDRESS OF VTS	4BYTES
16 TO 27	RESERVED	RESERVED	12BYTES
28 TO 31	VTSI_EA	END ADDRESS OF VTSI	4BYTES
32 TO 33	VERN	VERSION NUMBER OF DVD VIDEO SPECIFICATION	2BYTES
34 TO 37	VTS_CAT	VTS CATEGORY	90BYTES
38 TO 127	RESERVED	RESERVED	4BYTES
128 TO 131	VTSI_MAT_EA	END ADDRESS OF VTSI_MAT	60BYTES
132 TO 191	RESERVED	RESERVED	4BYTES
192 TO 195	VTSM_VOBS_SA	START ADDRESS OF VTSM_VOBS	4BYTES
196 TO 199	VTSIT_VOBS_SA	START ADDRESS OF VTSIT_VOBS	4BYTES
200 TO 203	VTS_PTT_SRPT_SA	START ADDRESS OF VTS_PTT_SRPT	4BYTES
204 TO 207	VTS_PGCIT_SA	START ADDRESS OF VTS_PGCIT	4BYTES
208 TO 211	VTSM_PGCI_UT_SA	START ADDRESS OF VTSM_PGCI_UT	4BYTES
212 TO 215	VTS_TMAPT_SA	START ADDRESS OF VTS_TMAPT	4BYTES
216 TO 219	VTSM_C_ADT_SA	START ADDRESS OF VTSM_C_ADT	4BYTES
220 TO 223	VTSM_VOBU_ADMAP_SA	START ADDRESS OF VTSIT_VOBU_ADMAP	4BYTES
224 TO 227	VTS_C_ADT_SA	START ADDRESS OF VTS_C_ADT	4BYTES
228 TO 231	VTS_VOBU_ADMAP_SA	START ADDRESS OF VTS_VOBU_ADMAP	4BYTES
232 TO 255	RESERVED	RESERVED	24BYTES
256 TO 257	VTSM_V_ATR	VIDEO ATTRIBUTE OF VTSM	2BYTES
258 TO 259	VTSM_AST_Ns	NUMBER OF AUDIO STREAMS OF VTSM	2BYTES
260 TO 267	VTSM_AST_ATR	AUDIO STREAM ATTRIBUTE OF VTSM	8BYTES
268 TO 323	RESERVED	RESERVED	56BYTES
324 TO 339	RESERVED	RESERVED	16BYTES
340 TO 341	VTSM_SPST_Ns	NUMBER OF SUB-PICTURE STREAMS OF VTSM	2BYTES
342 TO 347	VTSM_SPST_ATR	SUB-PICTURE STREAMS ATTRIBUTE TABLE OF VTSM	6BYTES
348 TO 511	RESERVED	RESERVED	164BYTES
512 TO 513	VTS_V_ATR	VIDEO ATTRIBUTE OF VTS	2BYTES
514 TO 515	VTS_AST_Ns	NUMBER OF AUDIO STREAMS OF VTS	2BYTES
516 TO 579	VTS_AST_ATRT	AUDIO STREAM ATTRIBUTE TABLE OF VTS	64BYTES
580 TO 595	RESERVED	RESERVED	16BYTES
596 TO 597	VTS_SPST_Ns	NUMBER OF SUB-PICTURE STREAMS OF VTS	2BYTES
598 TO 789	VTS_SPST_ATRT	SUB-PICTURE STREAMS ATTRIBUTE TABLE OF VTS	192BYTES
790 TO 791	RESERVED	RESERVED	2BYTES
792 TO 983	VTS_MU_AST_ATRT	MULTICHANNEL AUDIO STREAMS ATTRIBUTE TABLE OF VTS	192BYTES
984 TO 1023	RESERVED	RESERVED	40BYTES
1024 TO 2047	RESERVED	RESERVED	1024BYTES

FIG. 7



VTS\_AST\_ATRT

RBP	CONTENTS	NUMBER OF BYTES
516 TO 523	VTS_AST_ATR OF AUDIO STREAM #0	8BYTES
524 TO 531	VTS_AST_ATR OF AUDIO STREAM #1	8BYTES
532 TO 539	VTS_AST_ATR OF AUDIO STREAM #2	8BYTES
540 TO 547	VTS_AST_ATR OF AUDIO STREAM #3	8BYTES
548 TO 555	VTS_AST_ATR OF AUDIO STREAM #4	8BYTES
556 TO 563	VTS_AST_ATR OF AUDIO STREAM #5	8BYTES
564 TO 571	VTS_AST_ATR OF AUDIO STREAM #6	8BYTES
572 TO 579	VTS_AST_ATR OF AUDIO STREAM #7	8BYTES

FIG. 8A

VTS\_AST\_ATR

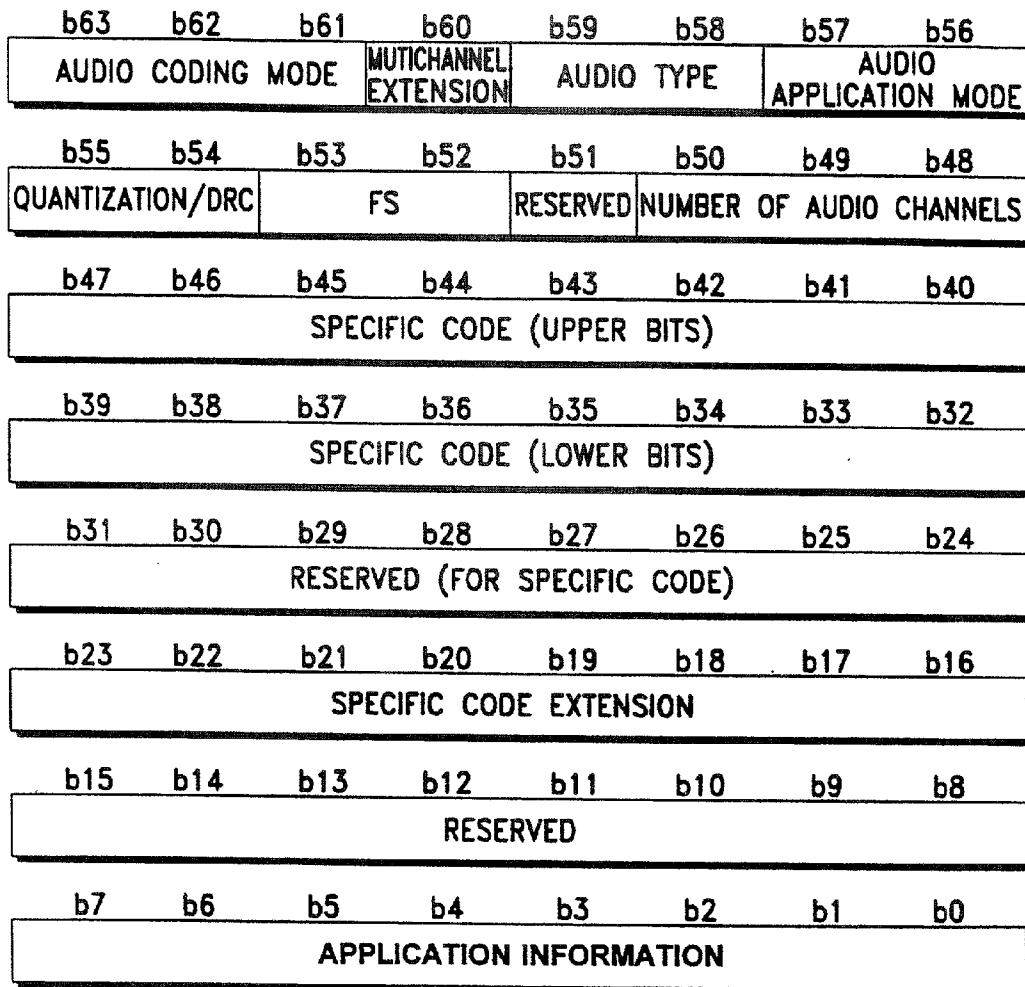

FIG. 8B

RBP	CONTENTS	NUMBER OF BYTES
792 TO 815	VTS_MU_AST_ATR OF AUDIO STREAM #0	24BYTES
816 TO 839	VTS_MU_AST_ATR OF AUDIO STREAM #1	24BYTES
840 TO 863	VTS_MU_AST_ATR OF AUDIO STREAM #2	24BYTES
864 TO 887	VTS_MU_AST_ATR OF AUDIO STREAM #3	24BYTES
888 TO 911	VTS_MU_AST_ATR OF AUDIO STREAM #4	24BYTES
912 TO 935	VTS_MU_AST_ATR OF AUDIO STREAM #5	24BYTES
936 TO 959	VTS_MU_AST_ATR OF AUDIO STREAM #6	24BYTES
960 TO 983	VTS_MU_AST_ATR OF AUDIO STREAM #7	24BYTES
	TOTAL	192BYTES

FIG. 9A

VTS\_MU\_AST\_ATR(1)

b191	b190	b189	b188	b187	b186	b185	b184
AUDIO MIXED FLAG		ACH0 MIX MODE		AUDIO CHANNEL CONTENTS			
b183	b182	b181	b180	b179	b178	b177	b176
AUDIO MIXED FLAG		ACH1 MIX MODE		AUDIO CHANNEL CONTENTS			
b175	b174	b173	b172	b171	b170	b169	b168
AUDIO MIXING PHASE		ACH2 MIX MODE		AUDIO CHANNEL CONTENTS			
b167	b166	b165	b164	b163	b162	b161	b160
AUDIO MIXING PHASE		ACH3 MIX MODE		AUDIO CHANNEL CONTENTS			
b159	b158	b157	b156	b155	b154	b153	b152
AUDIO MIXING PHASE		ACH4 MIX MODE		AUDIO CHANNEL CONTENTS			
b151	b150	b149	b148	b147	b146	b145	b144
AUDIO MIXING PHASE		ACH5 MIX MODE		AUDIO CHANNEL CONTENTS			
b143	b142	b141	b140	b139	b138	b137	b136
AUDIO MIXING PHASE		ACH6 MIX MODE		AUDIO CHANNEL CONTENTS			
b135	b134	b133	b132	b131	b130	b129	b128
AUDIO MIXING PHASE		ACH7 MIX MODE		AUDIO CHANNEL CONTENTS			

FIG. 9B

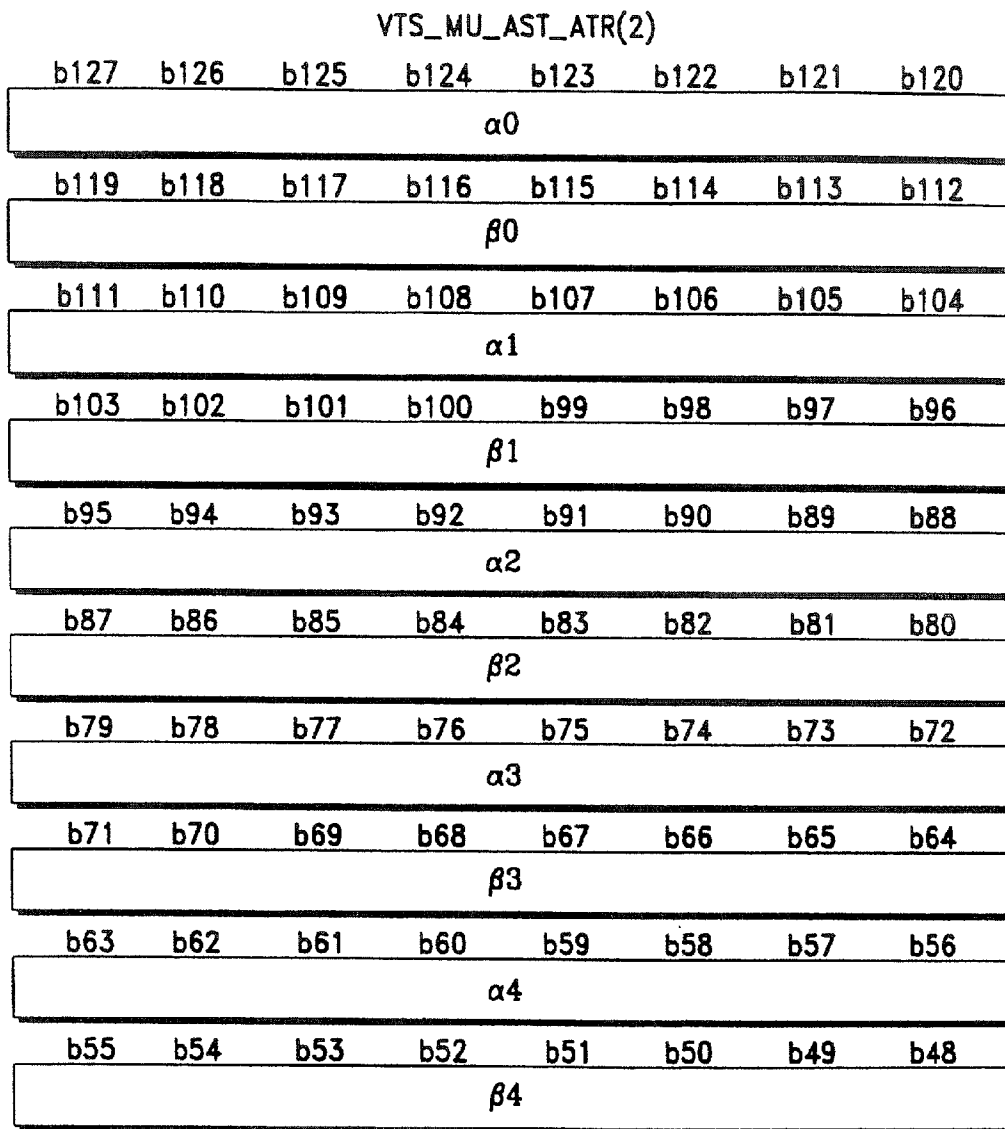
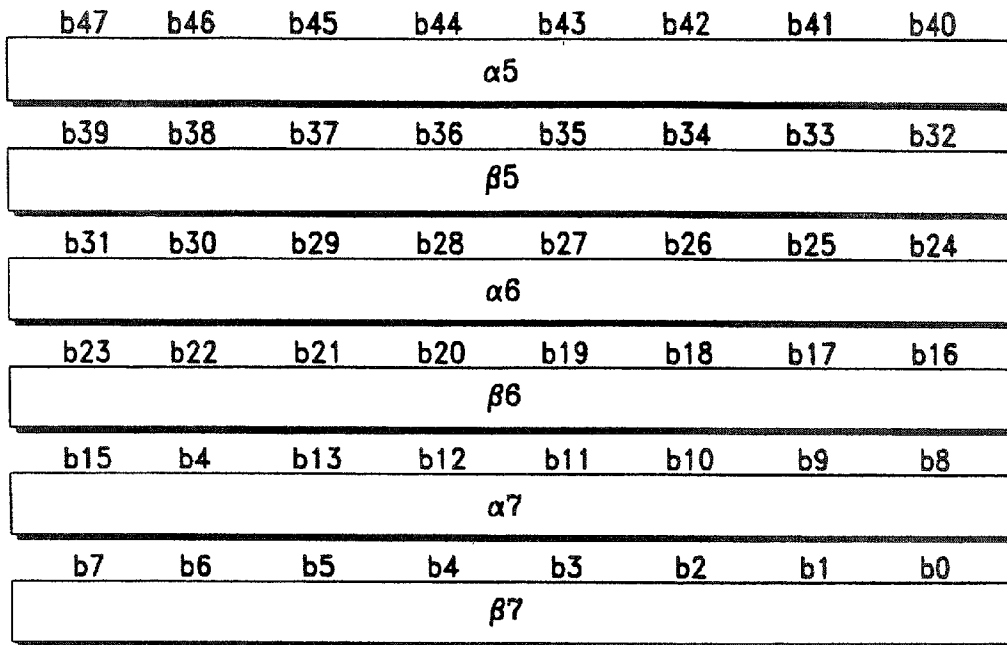

FIG. 9C



**FIG. 9D**

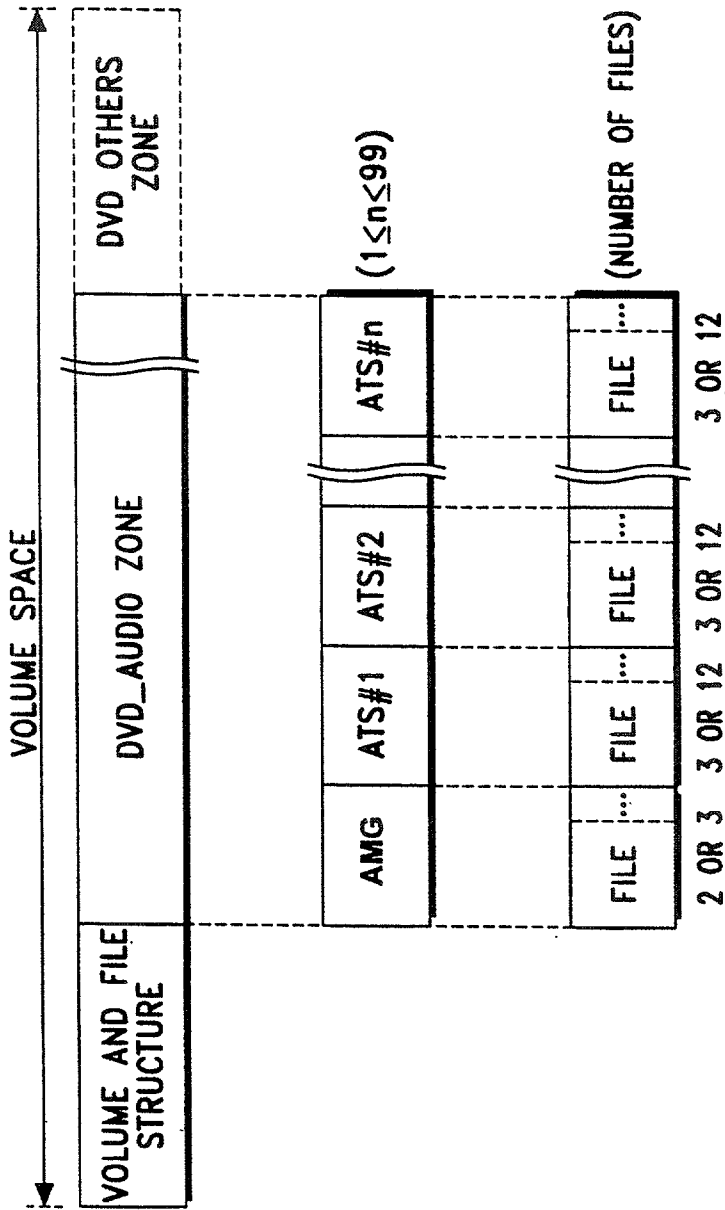

FIG. 10

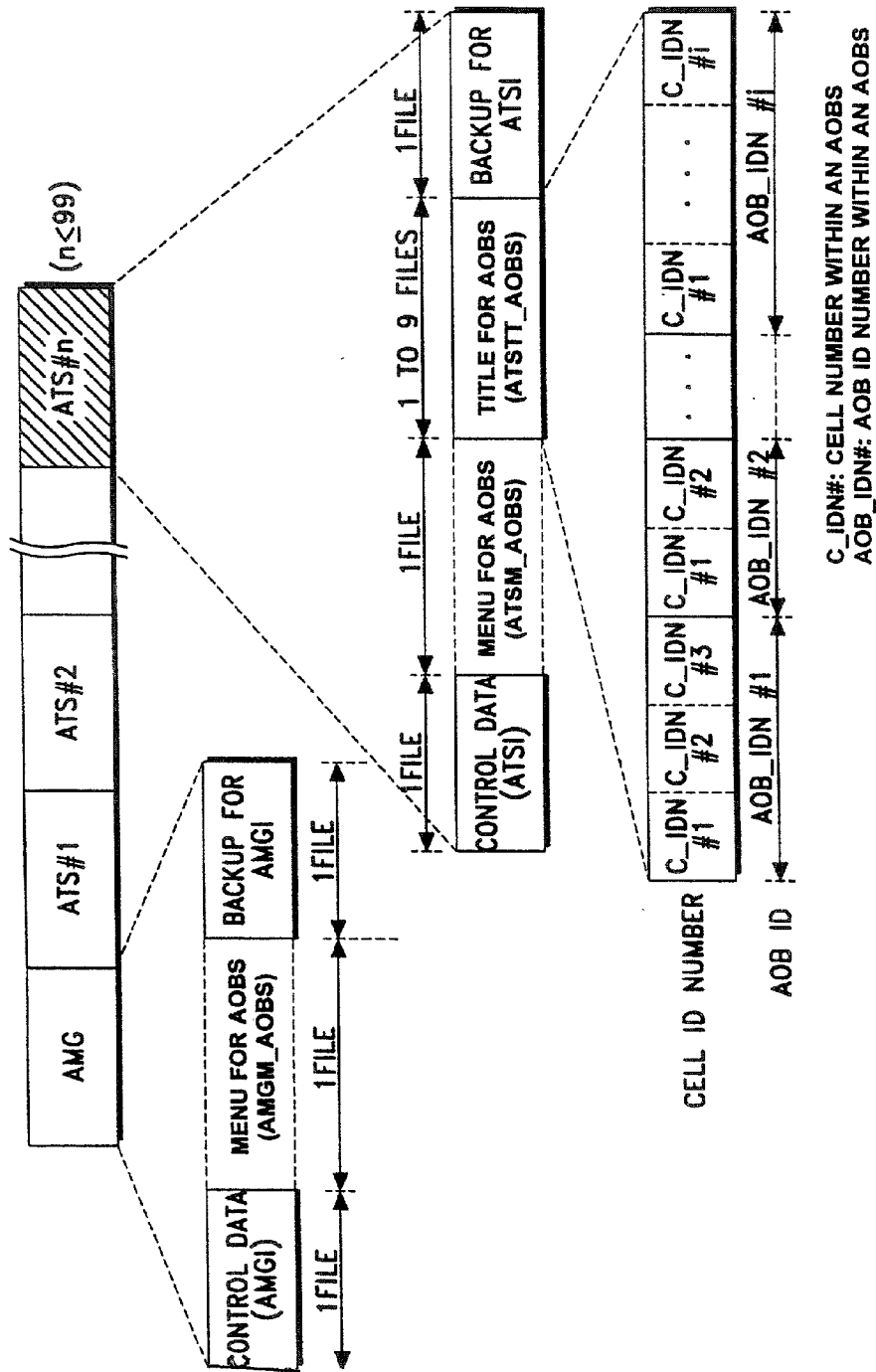

FIG. 11



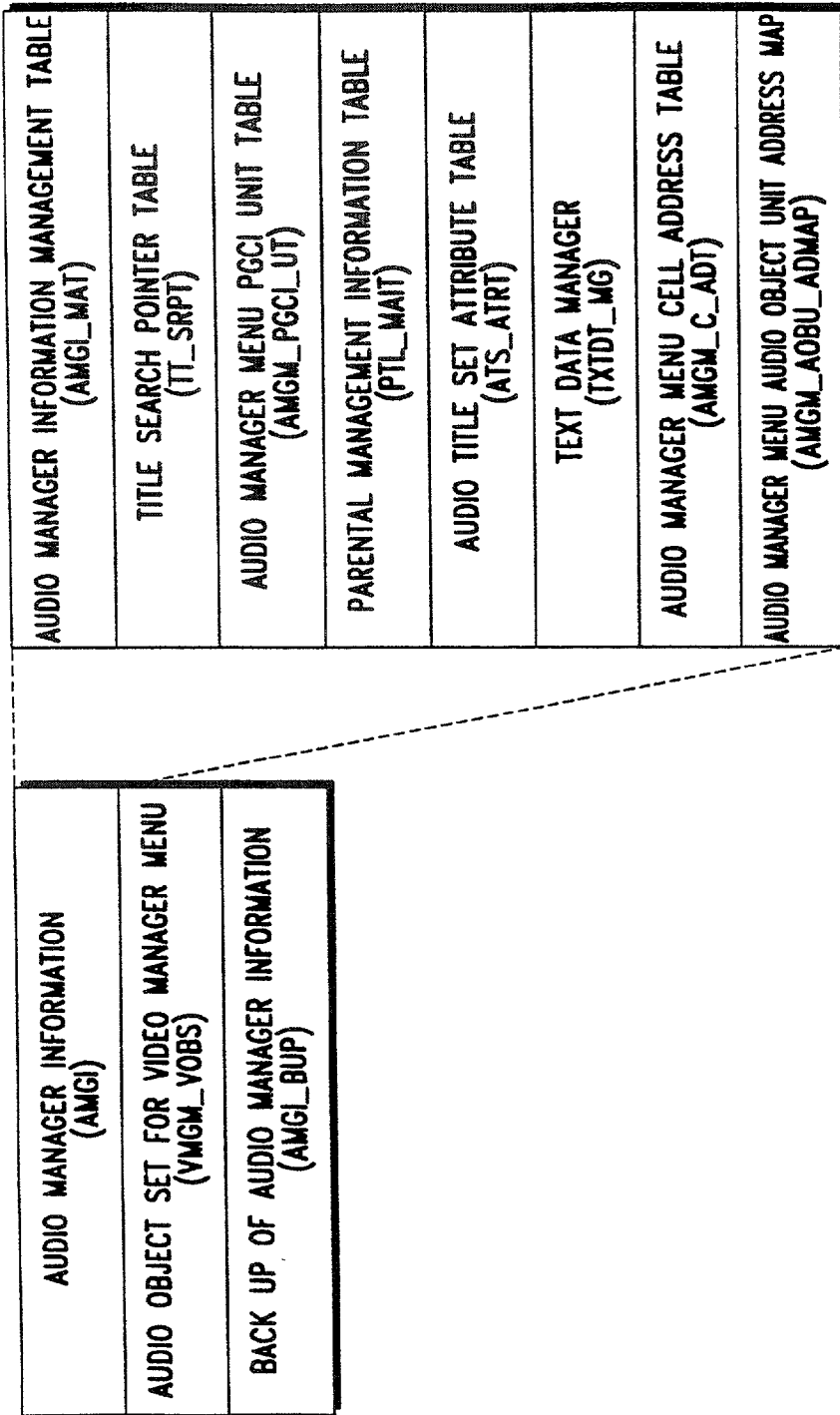

FIG. 12

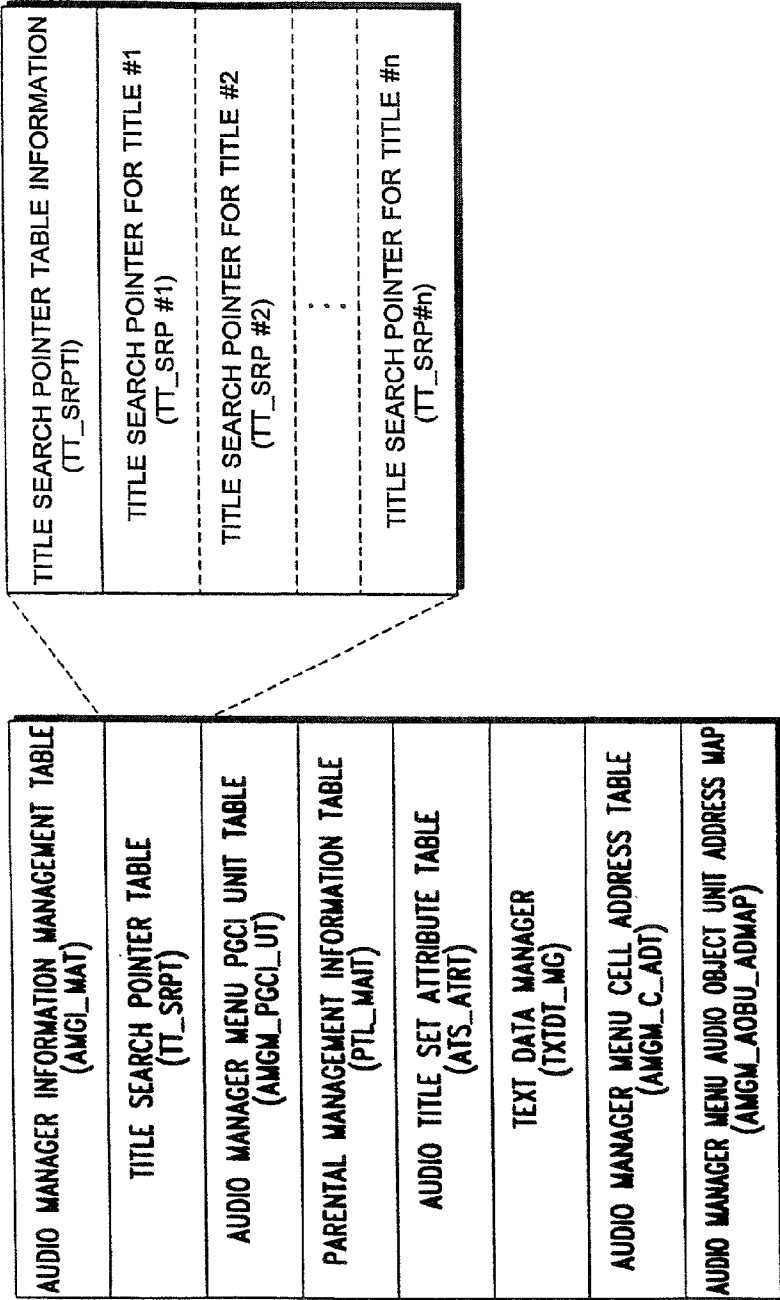

FIG. 13

AUDIO TITLE SET INFORMATION (ATSI)	AUDIO TITLE SET INFORMATION MANAGEMENT TABLE (ATSI_MAT)
AUDIO OBJECT SET FOR AUDIO TITLE SET MENU (ATSM_AOBS)	AUDIO TITLE SET PART_OF_TITLE SEARCH POINTER TABLE (ATS_PTT_SRPT)
AUDIO OBJECT SET FOR AUDIO TITLE SET TITLE (ATSTT_AOBS)	AUDIO TITLE SET PROGRAM CHAIN INFORMATION TABLE (ATS_PGCIT)
BACKUP OF AUDIO TITLE SET INFORMATION (ATSI_BUP)	AUDIO TITLE SET MENU PGCJ UNIT TABLE (ATSM_PGCJ_UT)
	AUDIO TITLE SET TIME MAP TABLE (ATS_TMAPT)
	AUDIO TITLE SET MENU CELL ADDRESS TABLE (ATSM_C_ADT)
	AUDIO TITLE SET MENU AUDIO OBJECT UNIT ADDRESS MAP (ATSM_AOBU_ADMAP)
	AUDIO TITLE SET CELL ADDRESS TABLE (ATS_C_ADT)
	AUDIO TITLE SET AUDIO OBJECT UNIT ADDRESS MAP (ATS_AOBU_ADMAP)

FIG. 14

ATSI\_MAT

RBP		CONTENTS	NUMBER OF BYTES
0 TO 11	ATS_ID	ATS IDENTIFIER	12BYTES
12 TO 15	ATS_EA	END ADDRESS OF ATS	4BYTES
16 TO 27	RESERVED	RESERVED	12BYTES
28 TO 31	ATSI_EA	END ADDRESS OF ATSI	4BYTES
32 TO 33	VERN	VERSION NUMBER OF DVD VIDEO SPECIFICATION	2BYTES
34 TO 37	ATS_CAT	ATS CATEGORY	90BYTES
38 TO 127	RESERVED	RESERVED	4BYTES
128 TO 131	ATSI_MAT_EA	END ADDRESS OF ATSI_MAT	60BYTES
132 TO 191	RESERVED	RESERVED	4BYTES
192 TO 195	ATSM_VOBS_SA	START ADDRESS OF ATSM_AOBS	4BYTES
196 TO 199	ATSTT_VOBS_SA	START ADDRESS OF ATSTT_AOBS	4BYTES
200 TO 203	ATS_PTT_SRPT_SA	START ADDRESS OF ATS_PTT_SRPT	4BYTES
204 TO 207	ATS_PGCIT_SA	START ADDRESS OF ATS_PGCIT	4BYTES
208 TO 211	ATSM_PGCI_UT_SA	START ADDRESS OF ATSM_PGCI_UT	4BYTES
212 TO 215	ATS_TMAPT_SA	START ADDRESS OF ATS_TMAPT	4BYTES
216 TO 219	ATSM_C_ADT_SA	START ADDRESS OF ATSM_C_ADT	4BYTES
220 TO 223	ATSM_VOBU_ADMAP_SA	START ADDRESS OF ATSTT_AOBU_ADMAP	4BYTES
224 TO 227	ATS_C_ADT_SA	START ADDRESS OF ATS_C_ADT	4BYTES
228 TO 231	ATS_VOBU_ADMAP_SA	START ADDRESS OF ATS_AOBU_ADMAP	4BYTES
232 TO 255	RESERVED	RESERVED	24BYTES
256 TO 257	ATSM_V_ATR	VIDEO ATTRIBUTE OF ATSM	2BYTES
258 TO 259	ATSM_AST_Ns	NUMBER OF AUDIO STREAMS OF ATSM	2BYTES
260 TO 267	ATSM_AST_ATR	AUDIO STREAM ATTRIBUTE OF ATSM	8BYTES
268 TO 323	RESERVED	RESERVED	56BYTES
324 TO 339	RESERVED	RESERVED	16BYTES
340 TO 341	ATSM_SPST_Ns	NUMBER OF SUB-PICTURE STREAMS OF ATSM	2BYTES
342 TO 347	ATSM_SPST_ATR	SUB-PICTURE STREAMS ATTRIBUTE TABLE OF ATSM	6BYTES
348 TO 511	RESERVED	RESERVED	164BYTES
512 TO 513	ATS_V_ATR	VIDEO ATTRIBUTE OF ATS	2BYTES
514 TO 515	ATS_AST_Ns	NUMBER OF AUDIO STREAMS OF ATS	2BYTES
516 TO 579	ATS_AST_ATR	AUDIO STREAM ATTRIBUTE TABLE OF ATS	64BYTES
580 TO 595	RESERVED	RESERVED	16BYTES
596 TO 597	ATS_SPST_Ns	NUMBER OF SUB-PICTURE STREAMS OF ATS	2BYTES
598 TO 789	ATS_SPST_ATRT	SUB-PICTURE STREAMS ATTRIBUTE TABLE OF ATS	192BYTES
790 TO 791	RESERVED	RESERVED	2BYTES
792 TO 1298	ATS_MU_AST_ATRT	MULTICHANNEL AUDIO STREAMS ATTRIBUTE TABLE OF ATS	507BYTES
1299 TO 1299	RESERVED	RESERVED	749BYTES

FIG. 15

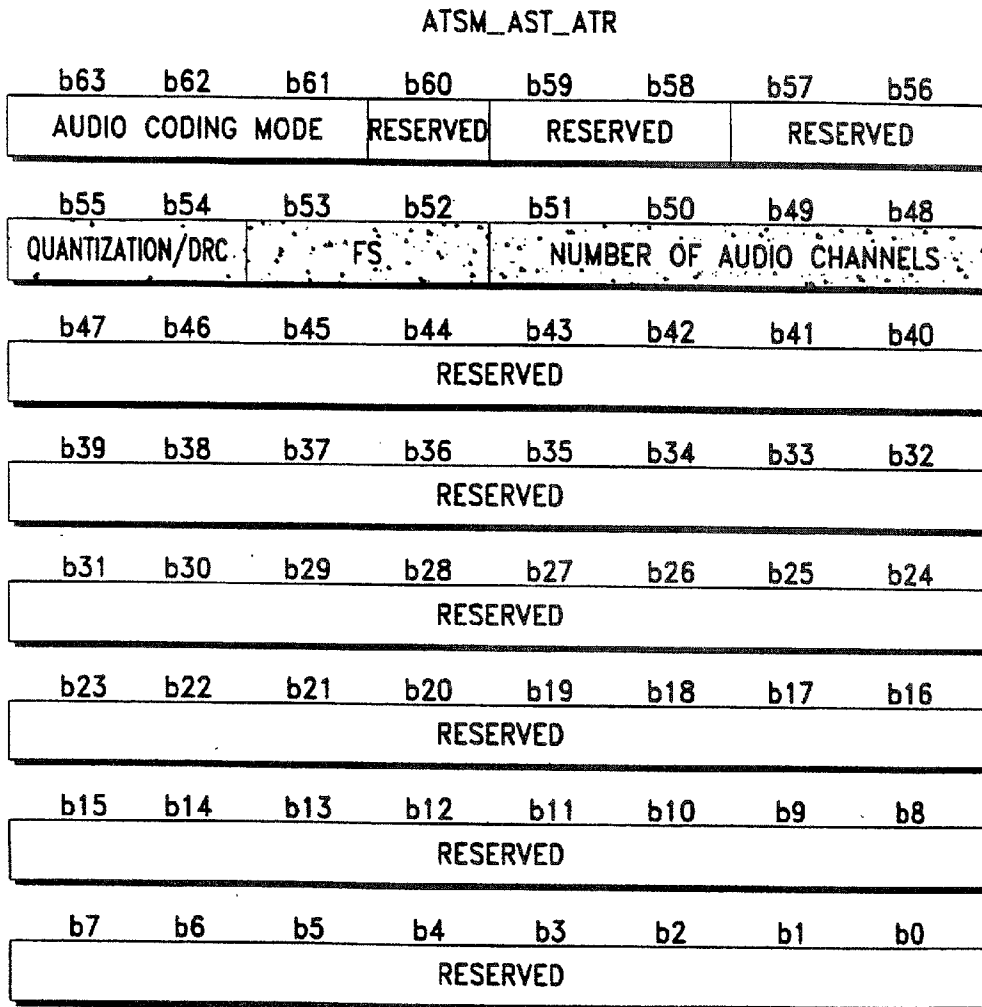

FIG. 16

ATS\_AST\_ATRT

RBP	CONTENTS	NUMBER OF BYTES
516 TO 523	ATS_AST_ATR OF AUDIO STREAM #0	8BYTES
524 TO 531	ATS_AST_ATR OF AUDIO STREAM #1	8BYTES
532 TO 539	ATS_AST_ATR OF AUDIO STREAM #2	8BYTES
540 TO 547	ATS_AST_ATR OF AUDIO STREAM #3	8BYTES
548 TO 555	ATS_AST_ATR OF AUDIO STREAM #4	8BYTES
556 TO 563	ATS_AST_ATR OF AUDIO STREAM #5	8BYTES
564 TO 571	ATS_AST_ATR OF AUDIO STREAM #6	8BYTES
572 TO 579	ATS_AST_ATR OF AUDIO STREAM #7	8BYTES

FIG. 17A

ATS\_AST\_ATR

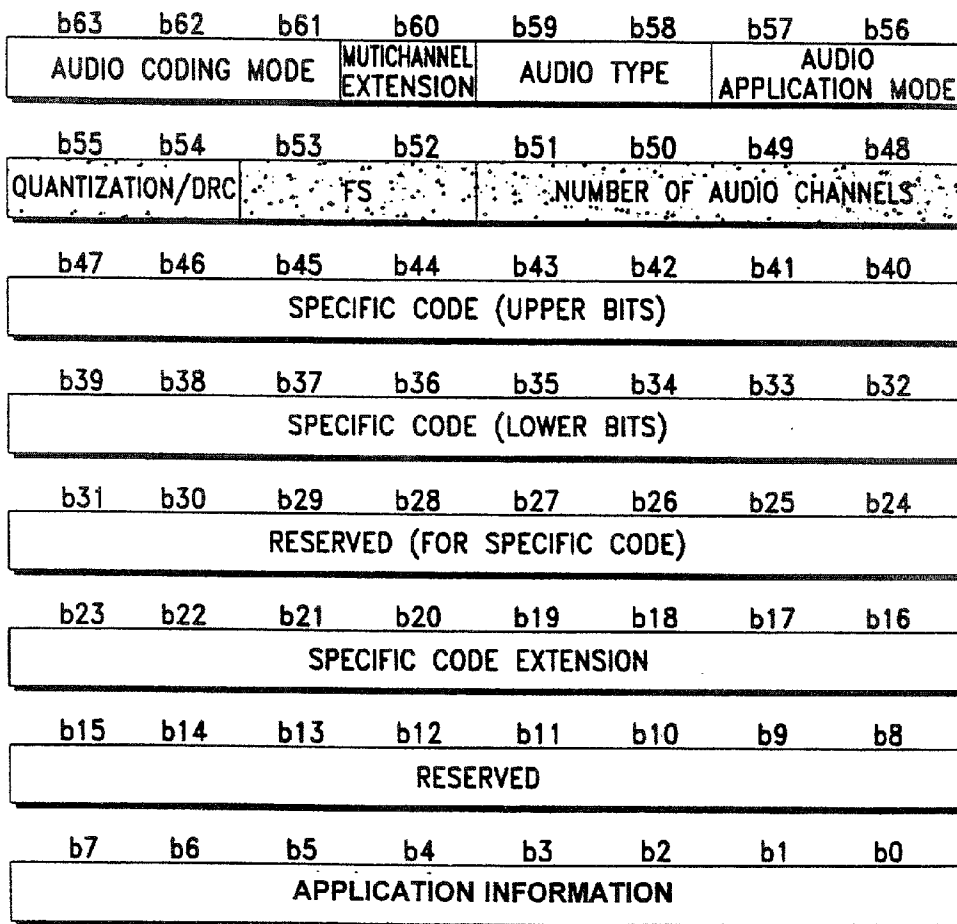

FIG. 17B

RBP	CONTENTS	NUMBER OF BYTES
792 TO 830	ATS_MU_AST_ATR OF AUDIO STREAM #0	39BYTES
831 TO 869	ATS_MU_AST_ATR OF AUDIO STREAM #1	39BYTES
870 TO 908	ATS_MU_AST_ATR OF AUDIO STREAM #2	39BYTES
909 TO 947	ATS_MU_AST_ATR OF AUDIO STREAM #3	39BYTES
948 TO 986	ATS_MU_AST_ATR OF AUDIO STREAM #4	39BYTES
987 TO 1025	ATS_MU_AST_ATR OF AUDIO STREAM #5	39BYTES
1026 TO 1064	ATS_MU_AST_ATR OF AUDIO STREAM #6	39BYTES
1065 TO 1103	ATS_MU_AST_ATR OF AUDIO STREAM #7	39BYTES
1104 TO 1142	ATS_MU_AST_ATR OF AUDIO STREAM #8	39BYTES
1143 TO 1181	ATS_MU_AST_ATR OF AUDIO STREAM #9	39BYTES
1182 TO 1220	ATS_MU_AST_ATR OF AUDIO STREAM #10	39BYTES
1221 TO 1259	ATS_MU_AST_ATR OF AUDIO STREAM #11	39BYTES
1260 TO 1298	ATS_MU_AST_ATR OF AUDIO STREAM #12	39BYTES
	TOTAL	507BYTES

FIG. 18A



ATS\_MU\_AST\_ATR\_EXT(1)

b39	b38	b37	b36	b35	b34	b33	b32
AUDIO MIXED FLAG		ACH8 MIX MODE		AUDIO CHANNEL CONTENTS			
b31	b30	b29	b28	b27	b26	b25	b24
AUDIO MIXED FLAG		ACH9 MIX MODE		AUDIO CHANNEL CONTENTS			
b23	b22	b21	b20	b19	b18	b17	b16
AUDIO MIXED FLAG		ACH10 MIX MODE		AUDIO CHANNEL CONTENTS			
b15	b14	b13	b12	b11	b10	b9	b8
AUDIO MIXED FLAG		ACH11 MIX MODE		AUDIO CHANNEL CONTENTS			
b7	b6	b5	b4	b3	b2	b1	b0
AUDIO MIXED FLAG		ACH12 MIX MODE		AUDIO CHANNEL CONTENTS			

FIG. 18B

ATS\_MU\_AST\_ATR\_EXT(2)

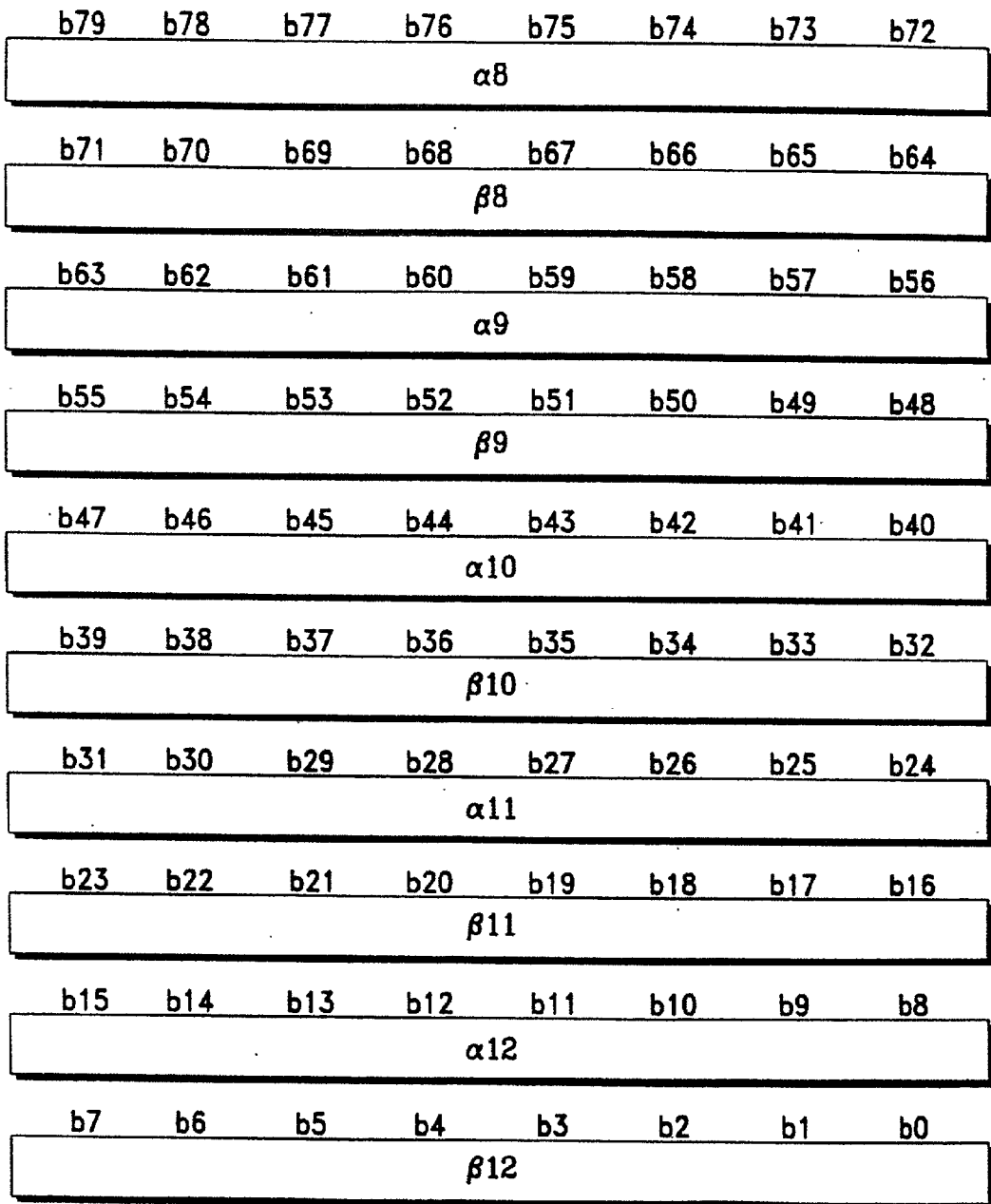

FIG. 18C

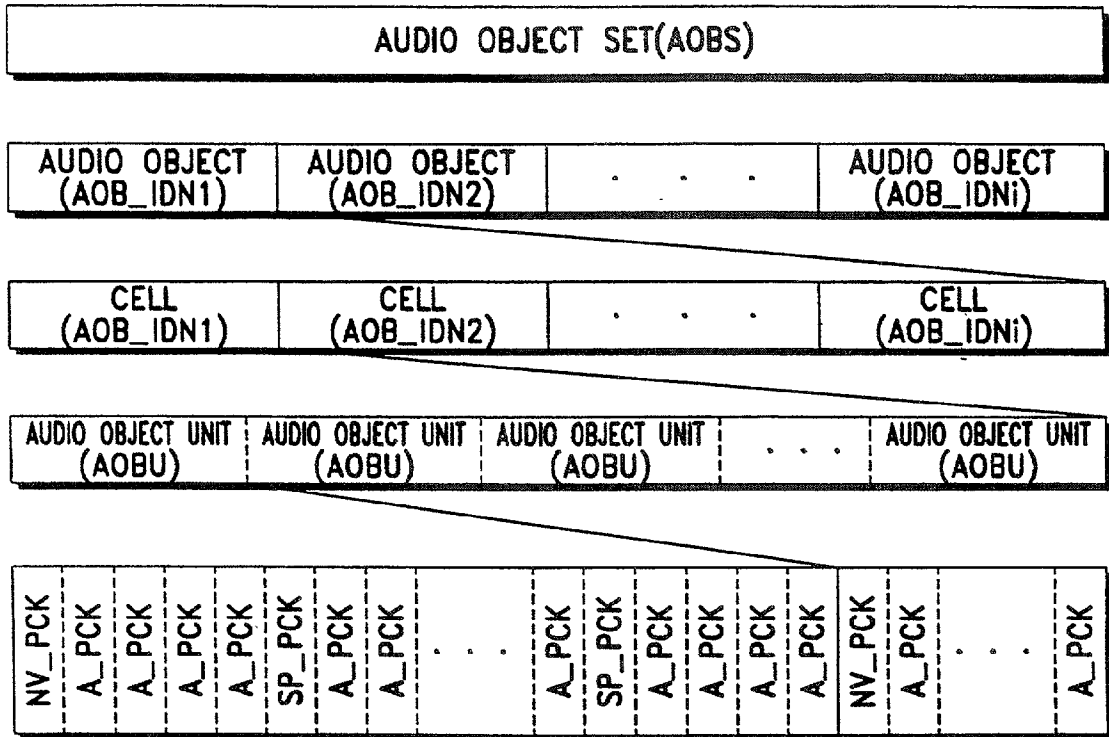

FIG. 19

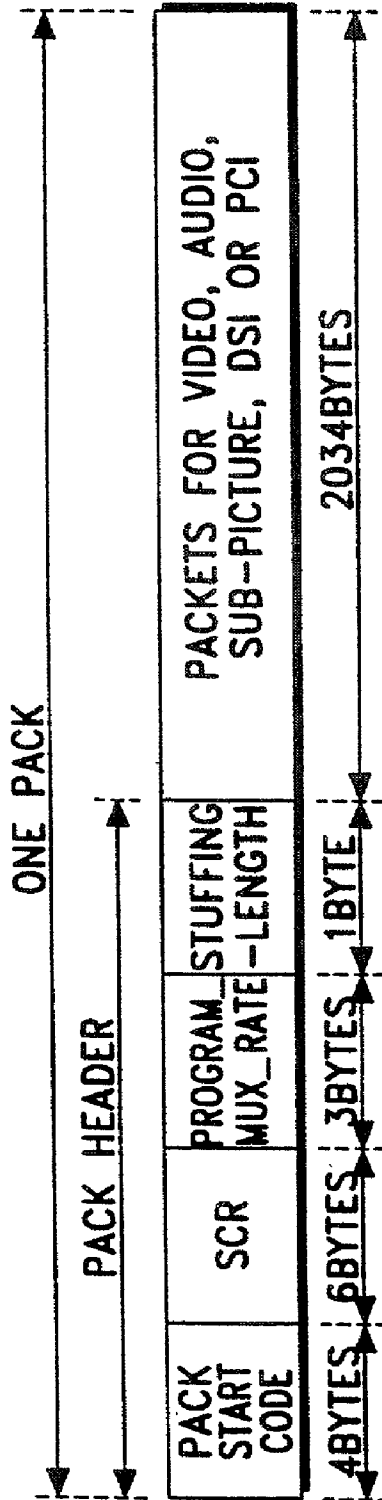

FIG. 20

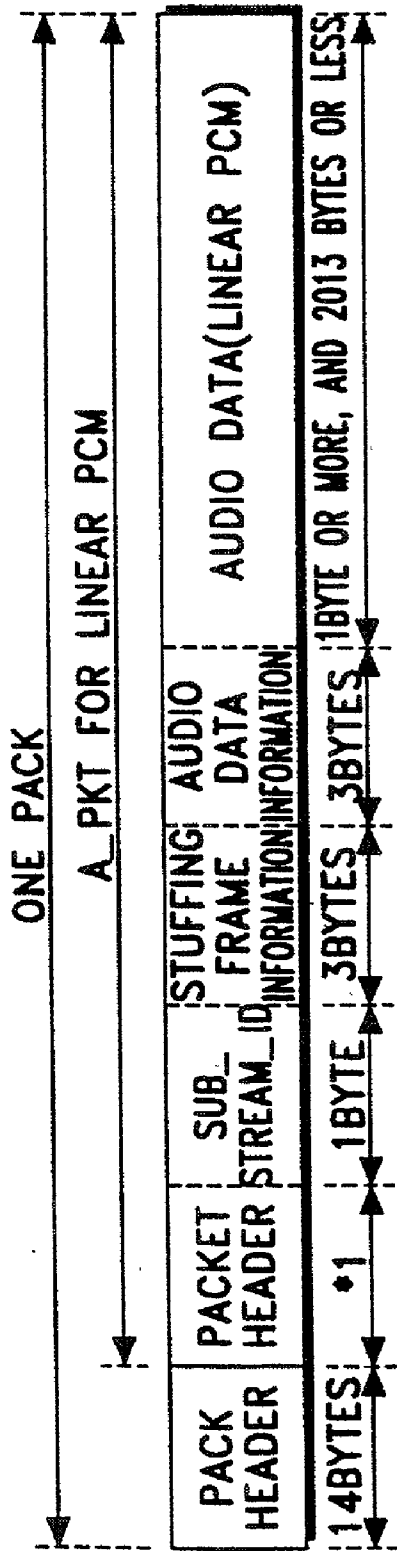

FIG. 21A

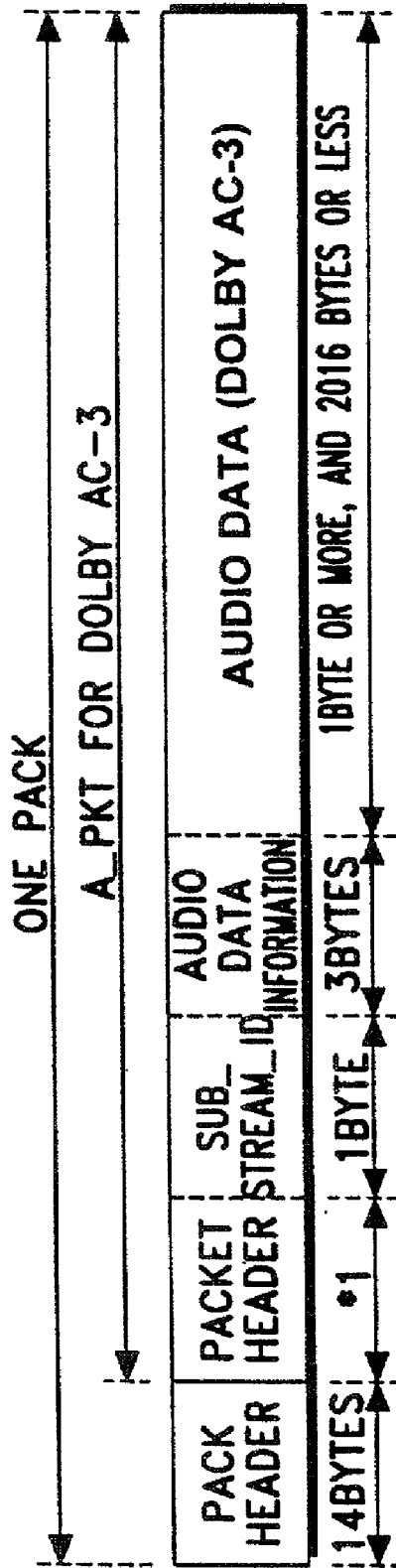

FIG. 21B

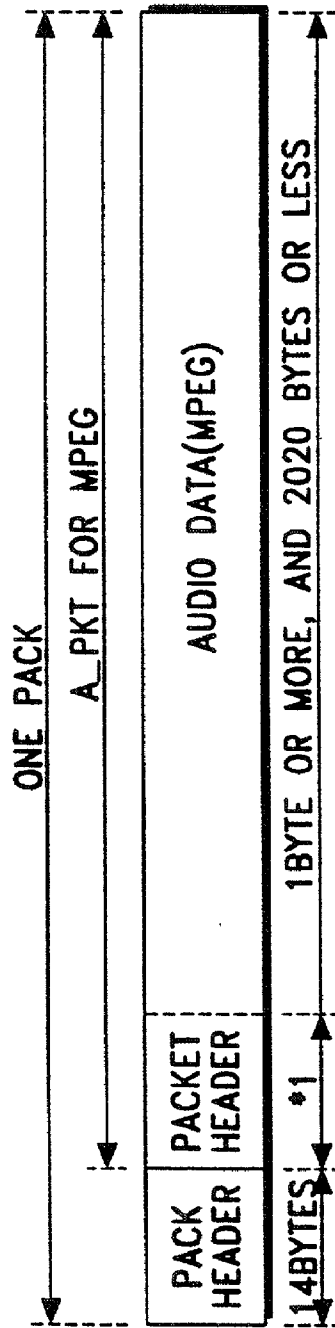

FIG. 21C

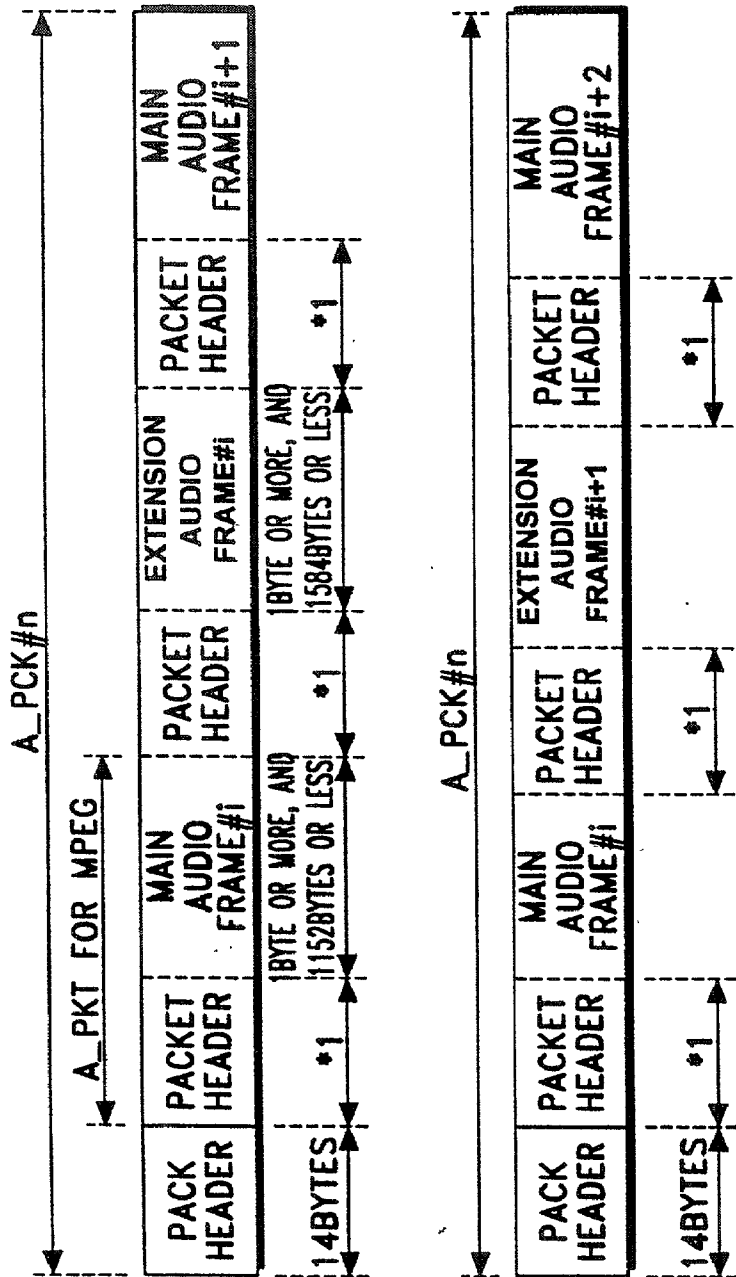

FIG. 21D



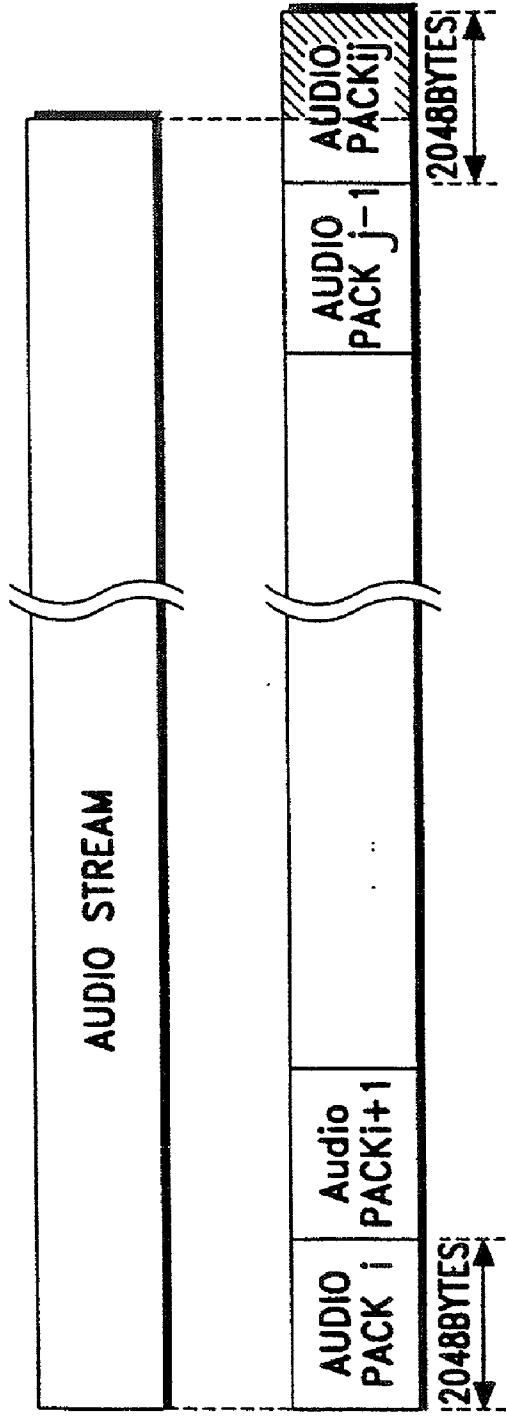

FIG. 22

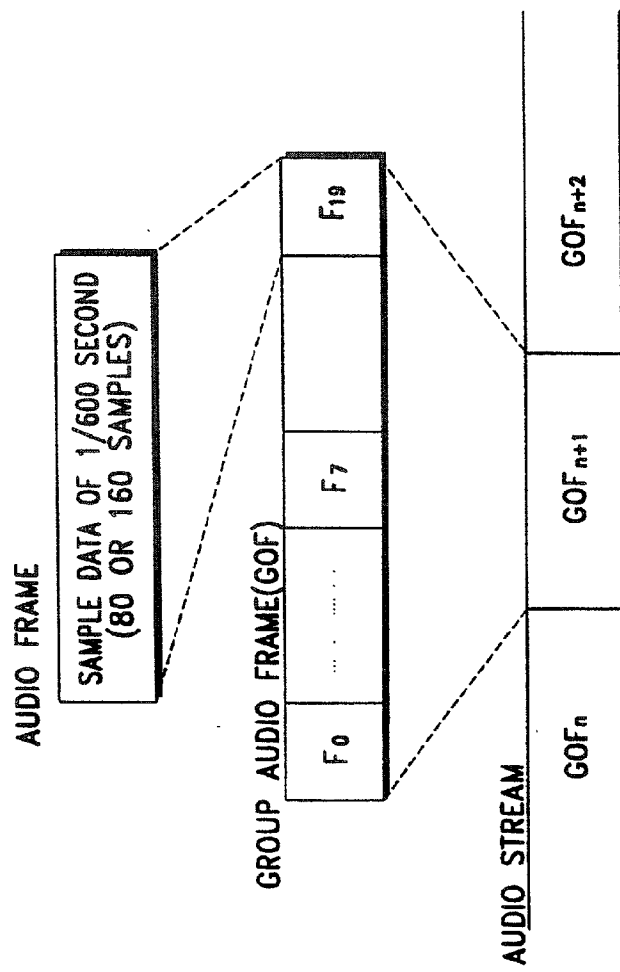

FIG. 23

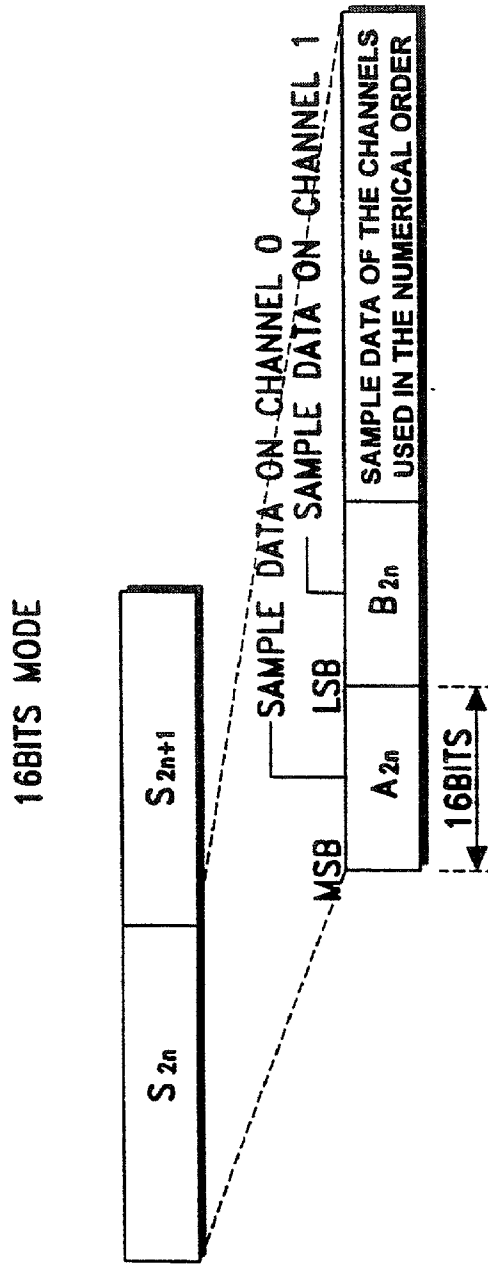
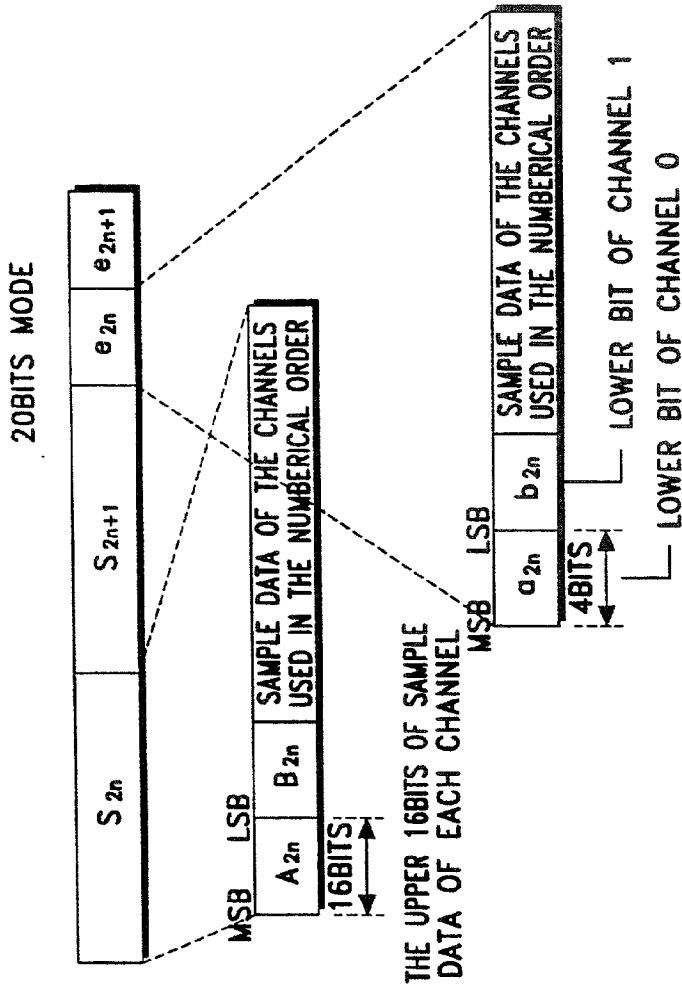
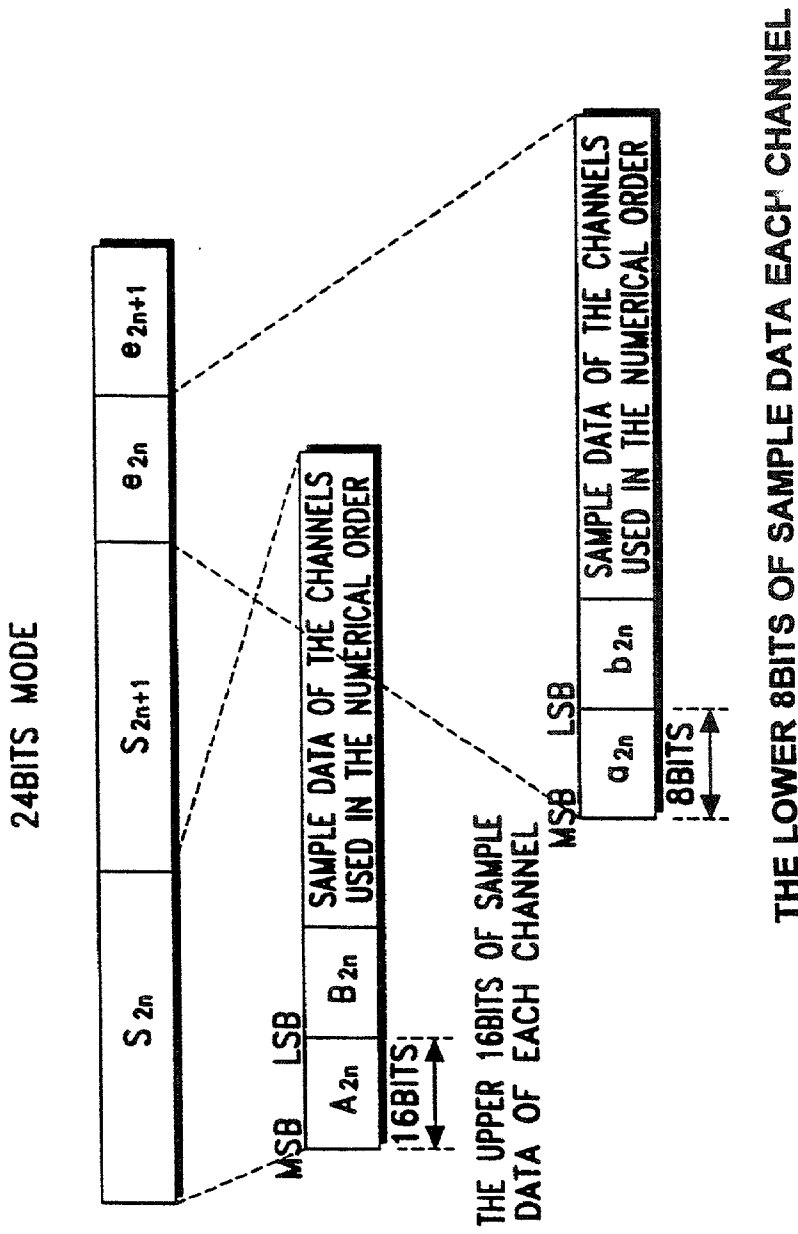

FIG. 24A



THE LOWER 8BITS OF SAMPLE DATA EACH CHANNEL

FIG. 24B



**FIG. 24C**

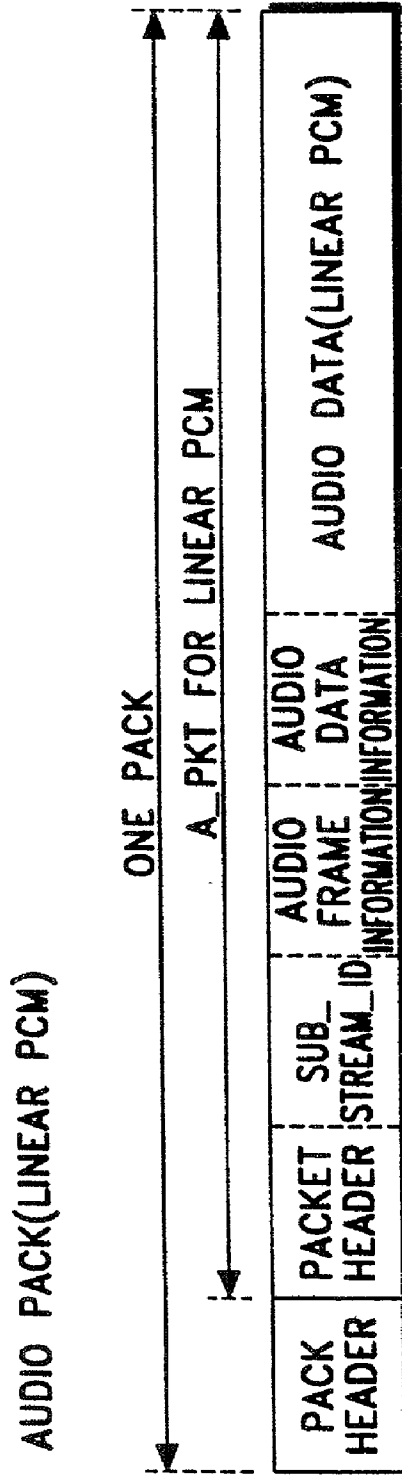

FIG. 25

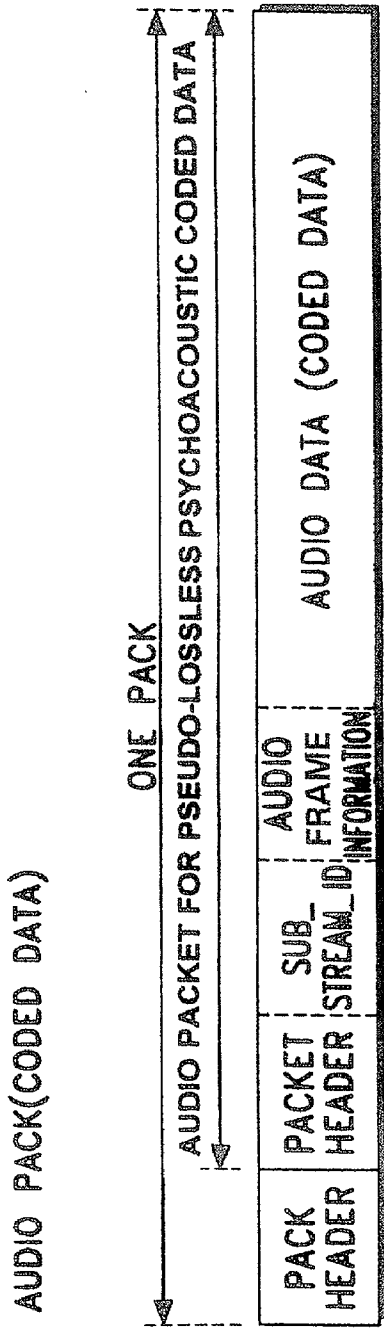

FIG. 26

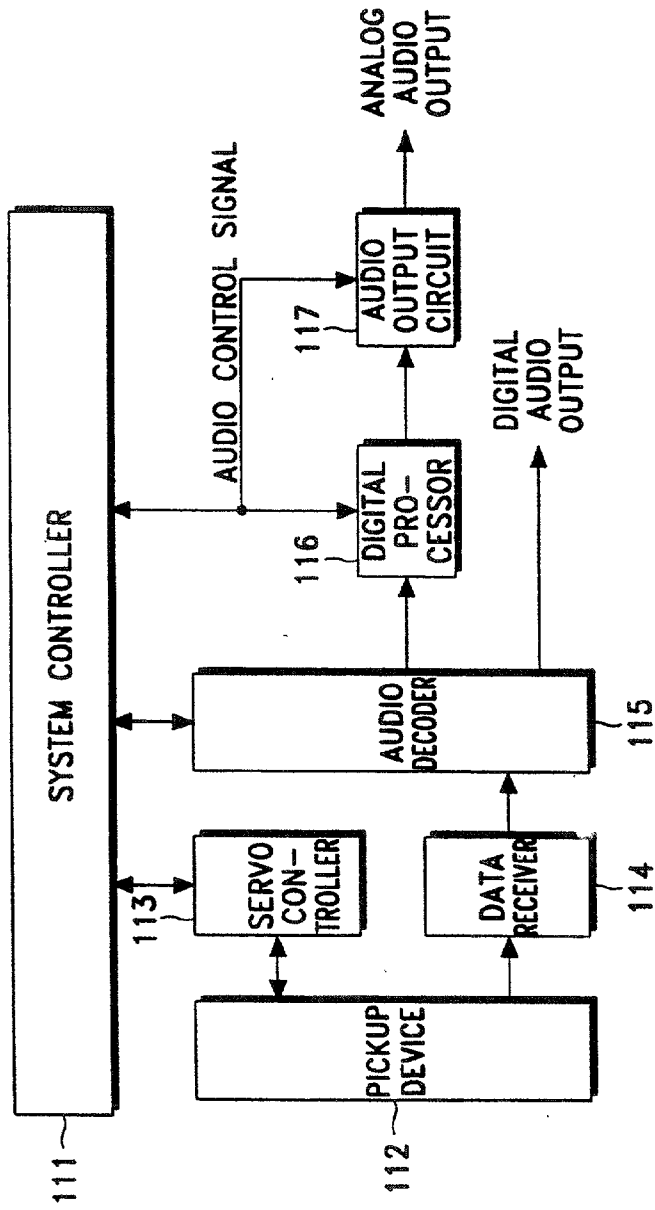

FIG. 27



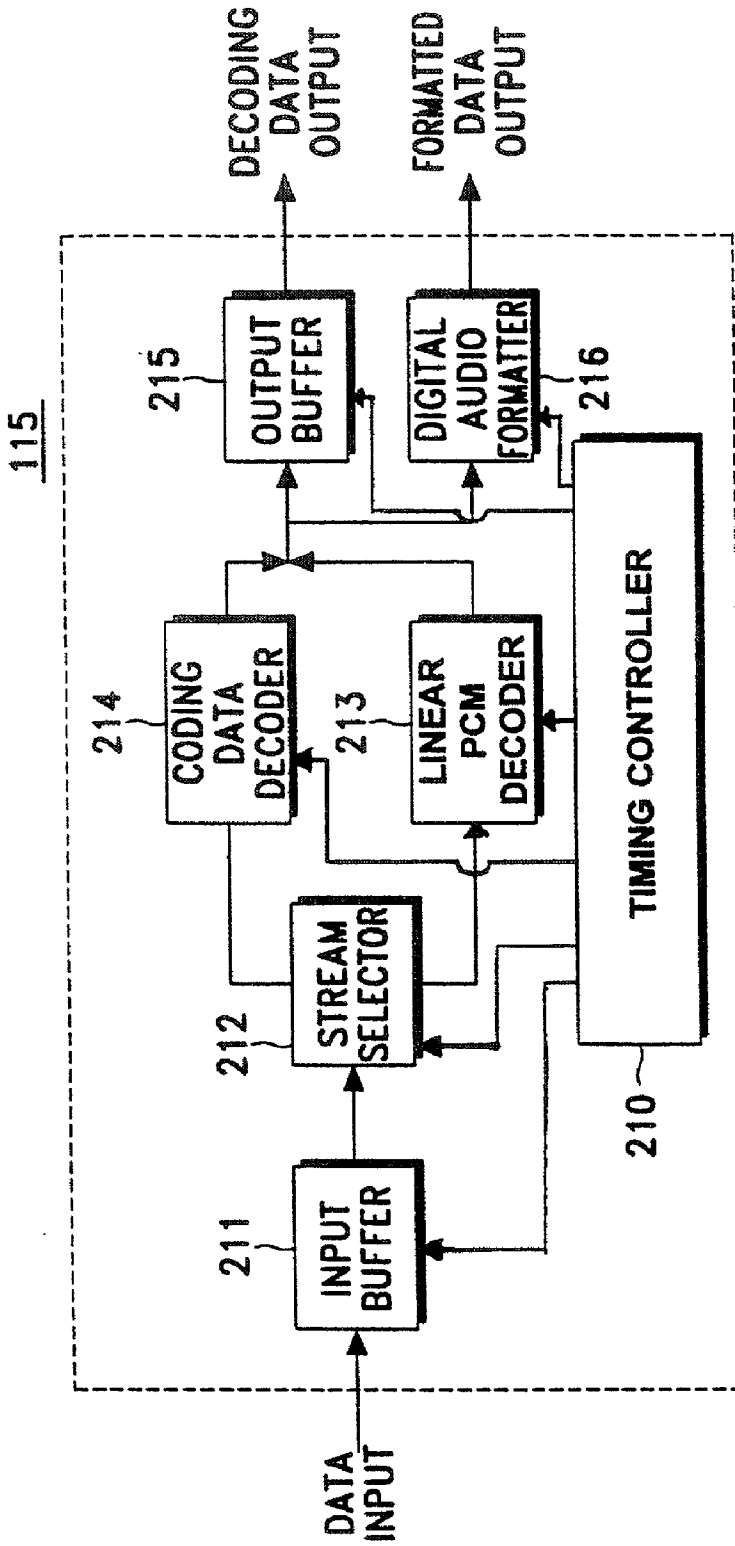

FIG. 28

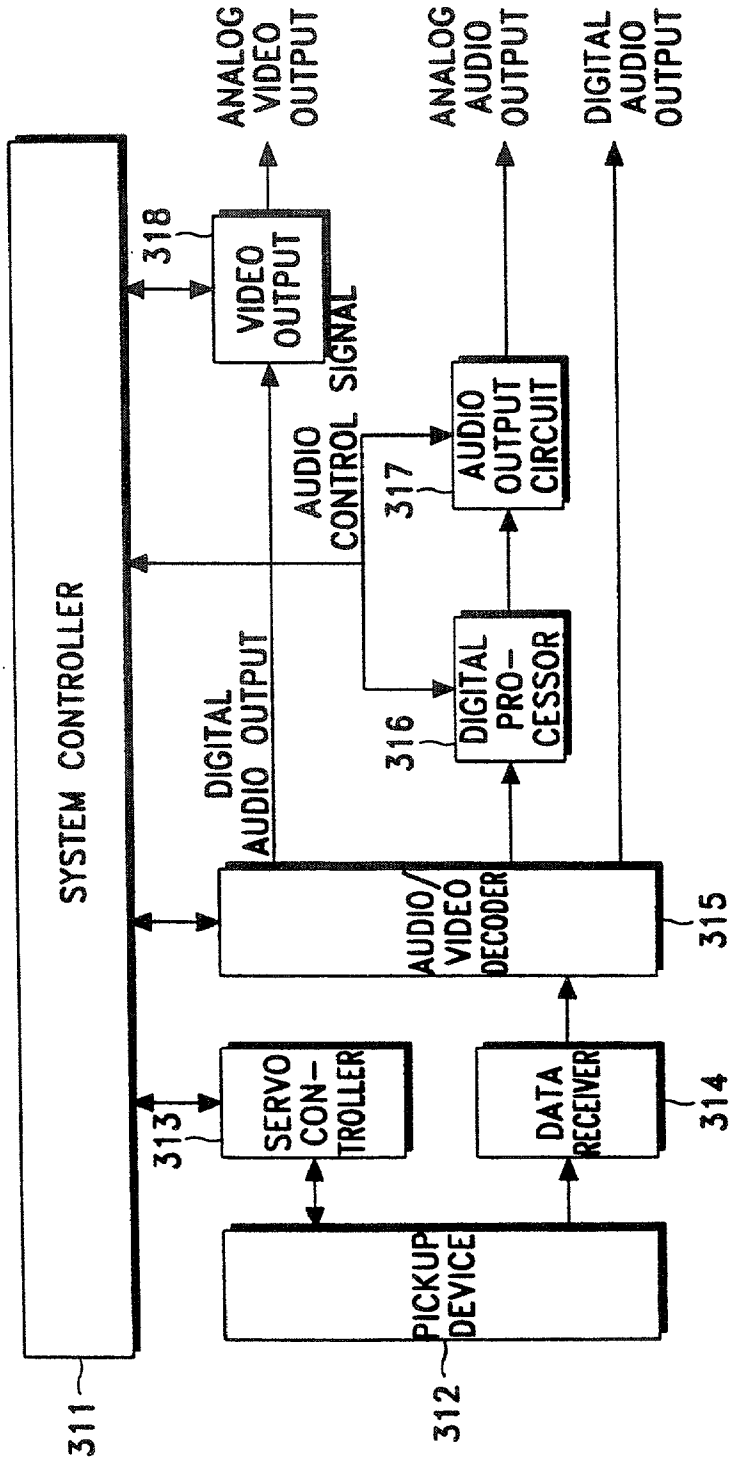

FIG. 29

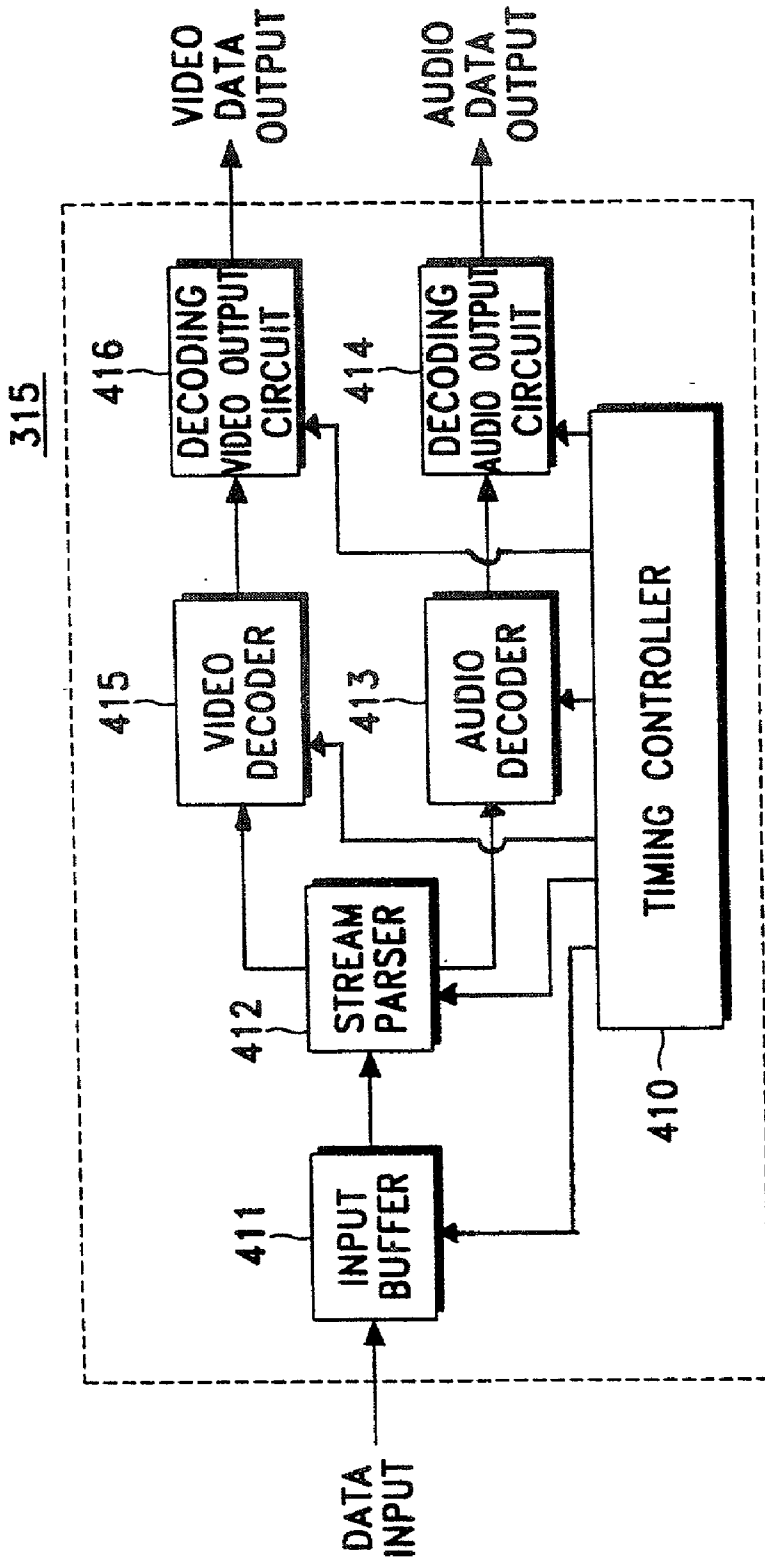

FIG. 30

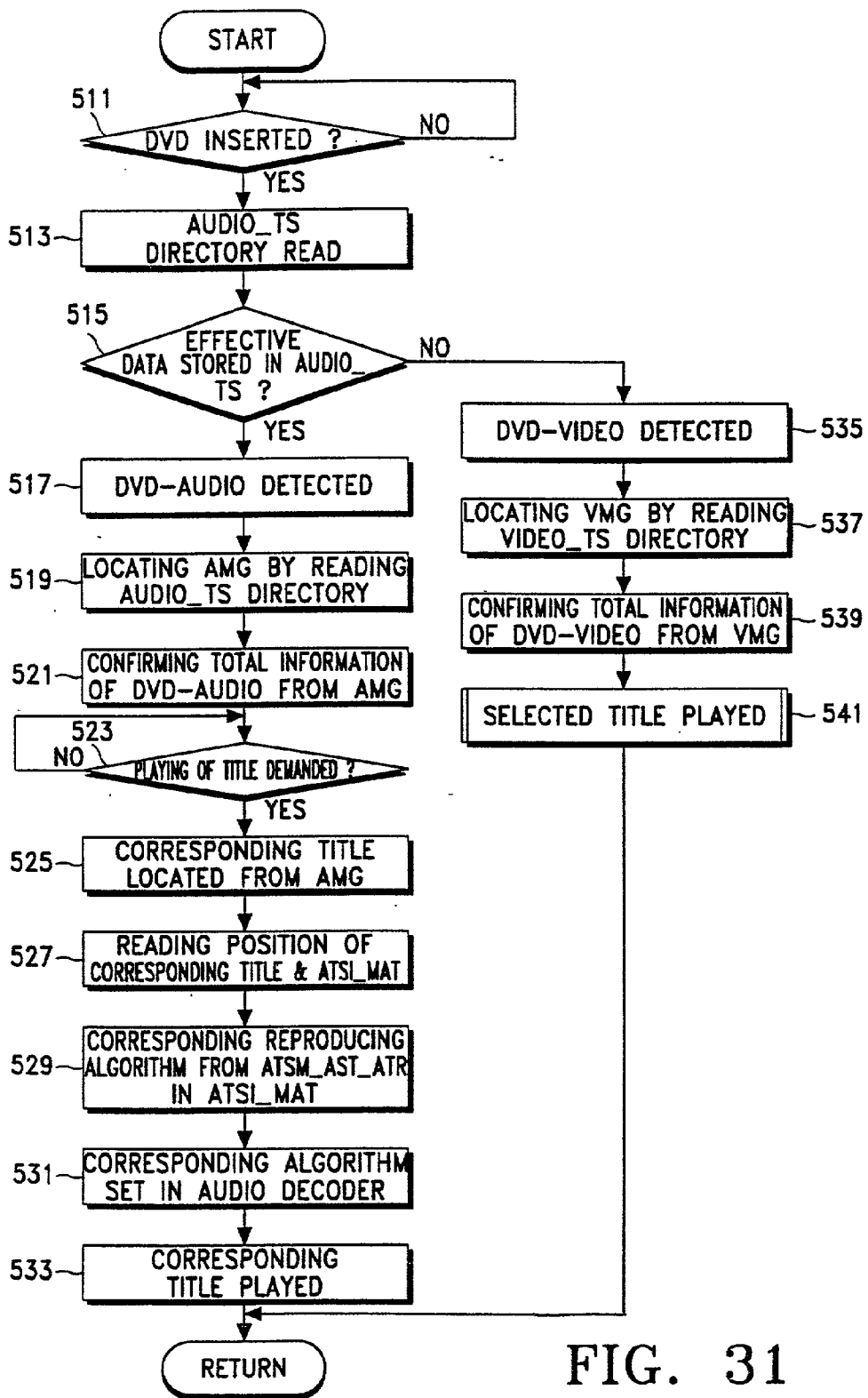

FIG. 31

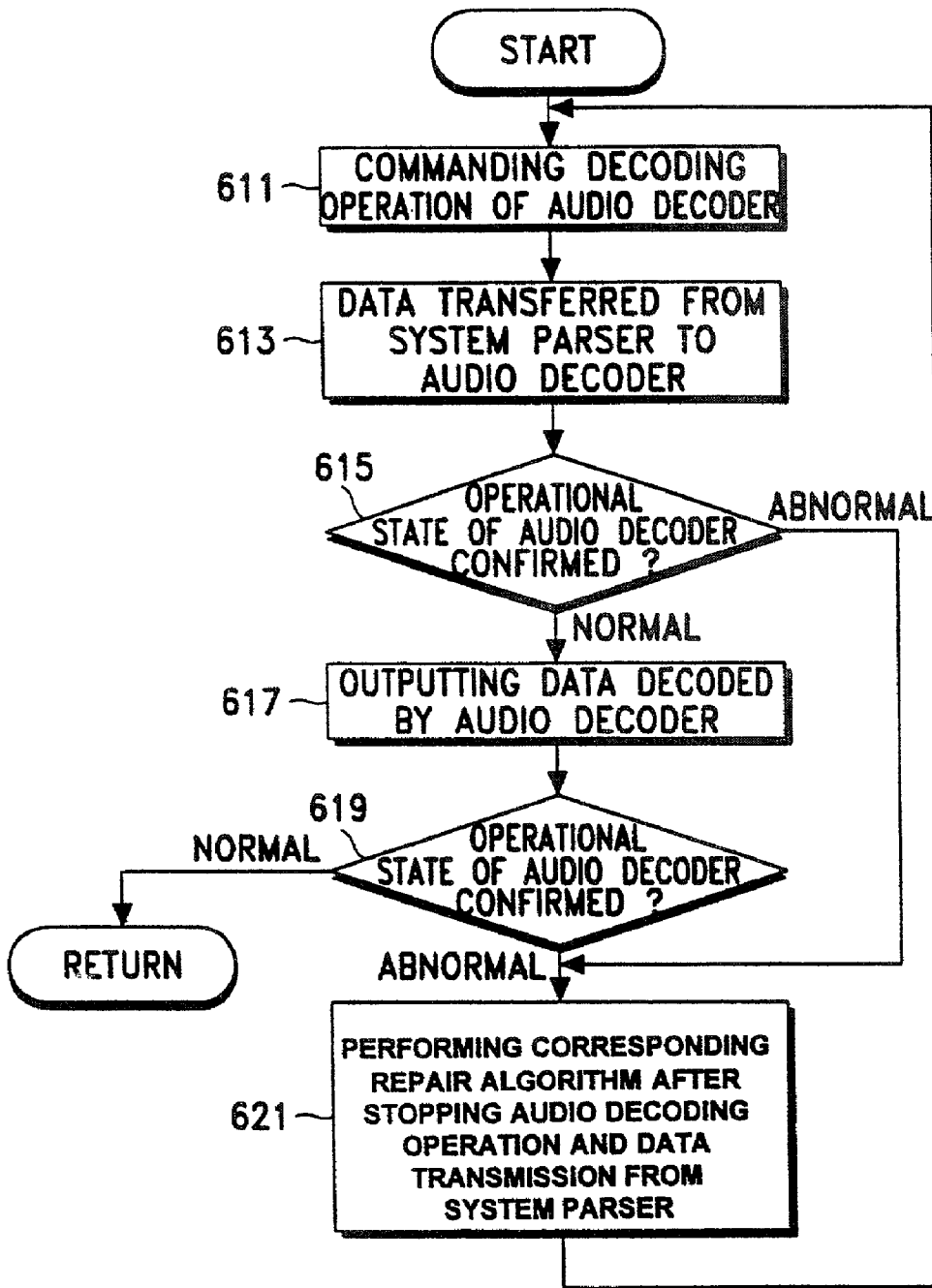

FIG. 32

**DVD-AUDIO DISK, AND APPARATUS AND  
METHOD FOR RECORDING DATA ON AND/OR  
REPRODUCING DATA FROM THE SAME**

CROSS-REFERENCE TO RELATED  
APPLICATIONS

[0001] This application claims the benefit of Korean Application No. 10330/1997, filed Mar. 25, 1997 and Korean Application No. 51861/1997, filed Oct. 9, 1997, in the Korean Patent Office, and U.S. patent application Ser. No. 09/047,363 filed in the U.S. Patent and Trademark Office on Mar. 25, 1998, now pending, which is a continuation-in-part of U.S. patent application Ser. No. 08/921,082, now abandoned, the disclosures of which are incorporated herein by reference.

BACKGROUND OF THE INVENTION

[0002] 1. Field of the Invention

[0003] The present invention relates to a digital versatile disk (DVD), and an apparatus and method for playing the DVD, and more particularly, to an audio DVD (hereinafter referred to as "DVD-Audio") and an apparatus and method for playing the same.

[0004] 2. Description of the Related Art

[0005] Recently, there has been developed a so-called video DVD (hereinafter referred to as "DVD-Video"), which has a considerably higher storage capacity than a laser disk (LD) so as to realize a significantly improved picture and sound quality. If the DVD is employed to store and retrieve only audio data, such DVD is called a DVD-Audio. The DVD-Audio provides means for storing and retrieving a large amount of audio data having a significantly improved quality compared to a compact disk (CD) or a digital audio tape (DAT).

[0006] The conventional CD stores an audio signal as linear pulse code modulated (PCM) audio data quantized into 16 bits by employing a sampling frequency of 44.1 KHz. The digital data stored in the CD is converted into analog signals by means of a CD player. The CD is much more convenient to use as compared to the previous micro-groove phonograph record (LP), but is regarded as having a lower sound quality than the analog LP. This is because the audio signals are sampled at 44.1 KHz and quantized into 16 bits to be stored into a CD. Moreover, the audible frequency range may be over 20 KHz, and the dynamic range must be over 120 dB. In addition, the CD can only store audio signals of at most two channels, and therefore is impossible to store and reproduce the audio data concerned with multi-channel music. In these circumstances, there have been proposed various methods to improve the sound quality of the CD by increasing the numbers of the sampling frequency and the audio channels.

[0007] The DVD provides means to record video and audio data at high density. In this case, the video data is recorded in the MPEG (Moving Picture Expert Group) while the audio data is recorded in the linear PCM format, dolby AC-3 format, MPEG format, etc. Hence, the DVD-Video player is designed to reproduce both video and audio data recorded in a DVD-Video. Such a DVD-Video prepared to necessarily store video data is very uneconomical in view of the storage space when used for storing audio data only.

[0008] The audio data recorded in a DVD-Video has a much higher quality than that in a CD since the audio data of the DVD has a higher sampling frequency and larger numbers of quantization bits and channels than that of the CD. Namely, the DVD player reproduces high quality audio data in multiple channels.

[0009] The DVD is possible to transfer data at 10.08 Mbps at most. This makes it possible to reproduce data sampled at 192 KHz in two channels. This also approaches the maximum sampling frequency proposed as a prerequisite for the next advanced audio system at the Advanced Digital Audio Conference held in Japan in April, 1996. Thus, if audio data are recorded in a DVD-Audio, the DVD player may reproduce sounds of a significantly improved quality over that reproduced from the DVD-Video.

SUMMARY OF THE INVENTION

[0010] It is an object of the present invention to provide a DVD-Audio for storing digital audio signals sampled at the maximum sampling frequency and quantized in the maximum number of bits with the number of channels limited by the data transfer speed in linear PCM.

[0011] It is another object of the present invention to provide a DVD-Audio for compressively coding digital audio signals sampled at the maximum sampling frequency and quantized in the maximum number of bits and storing them with the number of channels limited by the data transfer speed and the coding system in linear PCM.

[0012] It is still another object of the present invention to provide a DVD player for playing a DVD-Audio recorded in linear PCM and a method therefor.

[0013] It is a further object of the present invention to provide a DVD player for playing a DVD-Audio recorded with audio data compressively coded and a method therefor.

[0014] It is further another object of the present invention to provide a DVD player for properly playing a DVD-Video or DVD-Audio by distinguishing them.

[0015] According to a first aspect of the present invention, a DVD-Audio includes a data zone for storing data to be reproduced and an information zone for storing information on the data, the information zone including directories of a video title set (VIDEO\_TS) and an audio title set (AUDIO\_TS), wherein the AUDIO\_TS directory includes information on an audio manager (AMG) having information on audio titles, wherein the data zone includes the audio titles each having audio title set information (ATSI) followed by a plurality of contiguous audio objects (AOBs), the ATSI includes a plurality of audio stream attributes each having an audio coding mode indicator, first to third quantization bit numbers, first to third sampling frequencies and decoding algorithm information relating to the number of audio channels, and each of the AOBs includes a plurality of audio packs recorded with audio data corresponding to the decoding algorithm stored in the audio stream attribute.

[0016] According to a second aspect, an apparatus for playing the inventive DVD-Audio includes a data receiver for receiving the audio data retrieved from the DVD-Audio, a controller for generating an audio control signal containing an audio coding mode indicator, a sampling frequency, a channel number and quantization information by analyzing

information on the audio data or stopping the playing operation according to whether the AUDIO\_TS is detected to have effective data, an audio decoder to decode the received audio data and to multi-channel mix, sampling-frequency convert and requantize the decoded audio signal according to the audio control signal, and an audio output circuit to convert the decoded audio data into an analog audio signal.

[0017] According to a third aspect, a method for playing the inventive DVD-Audio includes the steps of locating the AMG when the AUDIO\_TS directory includes an effective data, checking out all information of the DVD-Audio from the information of the AMG, reading the data of the position of an audio title selected according to the position information of the AMG when receiving a command for reproducing the audio title, and setting the audio decoder to carry out the algorithm for reproducing the audio title by reading the audio stream attribute of the audio title set information management table (ATSI\_AMT).

[0018] The present invention will now be described more specifically with reference to the drawings attached only by way of example.

#### BRIEF DESCRIPTION OF THE DRAWINGS

[0019] FIG. 1 is an example of the directory structure of a DVD;

[0020] FIG. 2 is an example of the logical data structure of a DVD;

[0021] FIG. 3 is a diagram for illustrating the structure of the video manager (VMG) and VTS;

[0022] FIG. 4 is a diagram for illustrating the structure of the VMG of a DVD;

[0023] FIG. 5 is a diagram for illustrating the structure of a title search pointer table (TT\_SRPT) of a DVD;

[0024] FIG. 6 is a diagram for illustrating the structure of a video title set information (VTSI);

[0025] FIG. 7 is a diagram for illustrating the structure of a video title set management table (VTSI\_MAT);

[0026] FIG. 8A is a diagram for illustrating the structure of the video title set audio stream attribute table (VTS\_AST\_ATRT);

[0027] FIG. 8B is a diagram for illustrating the internal structure of VTS\_AST\_ATRT;

[0028] FIG. 9A is a diagram for illustrating the structure of a multi-channel audio stream attribute table of a video title set (VTS\_MU\_AST\_ATRT);

[0029] FIG. 9B is a diagram for illustrating the structure of a multi-channel audio stream attribute (1) of a video title set (VTS\_MU\_AST\_ATR(1));

[0030] FIGS. 9C and 9D are diagrams for illustrating the structure of the VTS\_MU\_AST\_ATR(2);

[0031] FIG. 10 is a diagram for illustrating a logical structure of the DVD-Audio;

[0032] FIG. 11 is a diagram for illustrating the structures of an audio manager (AMG) and audio title set (ATS) of the DVD-Audio;

[0033] FIG. 12 is a diagram for illustrating the structure of an audio manager information (AMGI) of the DVD-Audio;

[0034] FIG. 13 is a diagram for illustrating the structure of a title search pointer table (TT\_SRPT) of the DVD-Audio;

[0035] FIG. 14 is a diagram for illustrating the structure of an audio title set information (ATSI) of the DVD-Audio;

[0036] FIG. 15 is a diagram for illustrating the structure of an audio title set information management table (ATSI\_MAT) of the DVD-Audio;

[0037] FIG. 16 is a diagram for illustrating the internal structure of an audio stream attribute of an audio title set menu (ATSM\_AST\_ATR) of the DVD-Audio;

[0038] FIG. 17A is a diagram for illustrating the structure of an audio stream attribute table of an audio title set (ATS\_AST\_ATRT) of the DVD-Audio;

[0039] FIG. 17B is a diagram for illustrating the structure of an audio stream attribute of an audio title set (ATS\_AST\_ATR) of the DVD-Audio;

[0040] FIG. 18A is a diagram for illustrating the structure of a multi-channel audio stream attribute of an audio title set (ATS\_MU\_AST\_ATR) of the DVD-Audio;

[0041] FIG. 18B is a diagram for illustrating the structure of a first extension of a multi-channel audio stream attribute of an audio title set (ATS\_MU\_AST\_ATR\_EXT(1)) of the DVD-Audio;

[0042] FIG. 18C is a diagram for illustrating the structure of a second extension of a multi-channel audio stream attribute of the audio title set (ATS\_MU\_AST\_ATR\_EXT(2)) of the DVD-Audio;

[0043] FIG. 19 is a diagram for illustrating the structure of an audio object set (AOBS) of the DVD-Audio;

[0044] FIG. 20 is a diagram for illustrating a pack structure of the DVD-Audio;

[0045] FIGS. 21A to 21D are diagrams for illustrating various pack structures of the DVD-Audio;

[0046] FIG. 22 is a diagram for illustrating a linear PCM audio packet in the audio pack as shown in FIG. 21A;

[0047] FIG. 23 is a diagram for illustrating the structure of a linear PCMA audio frame of the DVD-Audio;

[0048] FIGS. 24A to 24C are diagrams for illustrating a sample data arrangement of the linear PCM;

[0049] FIG. 25 is a diagram for illustrating the structure of a linear audio packet of the DVD-Audio;

[0050] FIG. 26 is a diagram for illustrating the structure of a DTS audio packet of the DVD-Audio;

[0051] FIG. 27 is a block diagram for illustrating the functional structure of a DVD-Audio player according to a first embodiment of the present invention;

[0052] FIG. 28 is a block diagram for illustrating the structure of an audio decoder as shown in FIG. 27;

[0053] FIG. 29 is a block diagram for illustrating the functional structure of a DVD-Audio/DVD-Video player according to a second embodiment of the present invention;

[0054] FIG. 30 is a block diagram for illustrating the structure of an audio/video decoder as shown in FIG. 29;

[0055] FIG. 31 is a flow chart for illustrating the process of reproducing audio data from a DVD-Audio in the DVD-Audio player; and

[0056] FIG. 32 is a flow chart for illustrating the operation of an audio decoder in the DVD-Audio player.

#### DETAILED DESCRIPTION OF THE PREFERRED EMBODIMENTS

[0057] In the attached drawings, the same reference numerals are used to represent parts serving the same functions and detailed descriptions are omitted concerning the parts not essential to describe the inventive concept, for convenience's sake.

[0058] The data structure of the DVD-Audio is similar to that of the DVD-Video. Hence, the DVD-Audio includes a data zone to record the audio data and an information zone to record the information on the audio data. The DVD player may be embodied in the form of a DVD-Audio player or a DVD-Audio/Video player. Of course, the DVD player has a mechanism to determine whether an inserted DVD is a DVD-Audio or DVD-Video. The inventive DVD-Audio has almost the same structure as the DVD-Video with some partly changed data structure to achieve the audio data of high quality.

[0059] The fundamental file structure recorded in the information zone of the DVD-Audio is as shown in FIG. 1 for illustrating a directory structure for the DVD-Video and DVD-Audio. The directory structure generally includes a video title set directory (VIDEO\_TS), audio title set directory (AUDIO\_TS) and a user defined directory. Each of the directories contains a plurality of files of which the names shall be assigned. The directory structure is to represent the locations of the files in the disk. The files connected to the VIDEO\_TS are prepared for the DVD-Video and DVD-Video player while those connected to the AUDIO\_TS are prepared for the DVD-Audio and DVD-Audio player.

[0060] Generally, each of the DVD-Video and DVD-Audio contains both VIDEO\_TS and AUDIO\_TS. However, the DVD-Video has the AUDIO\_TS emptied (all of the information on the data stored in the DVD-Video disk being contained in the VIDEO\_TS) while the DVD-Audio has the AUDIO\_TS containing the information on the positions of the audio titles recorded on the disk and the VIDEO\_TS also containing the information on the positions of the titles of reproducible information (spec: e.g., sampling frequency) in the DVD-Video player. Hence, if a DVD has no effective data in the AUDIO\_TS, it is determined as being DVD-Video, or otherwise, i.e., if the DVD player detects effective data in the AUDIO\_TS, it determines the disk as being DVD-Audio. Namely, the DVD player detects the AUDIO\_TS of a DVD to distinguish DVD-Video and DVD-Audio.

[0061] The logical data structure of DVD-Video is illustrated in FIG. 1. The concept of the logical data structure of DVD-Video includes structure of a volume space, structure of a video manager (VMG), structure of a video title set (VTS), and structure of a video object set (VOBS).

[0062] Describing the logical data structure of the volume space with reference to FIG. 2, it includes the volume and

file structure, single DVD-Video zone and DVD others zone. The DVD-Video zone, which shall be assigned for the data structure of the DVD-Video, includes a single VMG and VTSs numbering from at least 1 to a maximum of 99. The VMG is allocated at the leading part of the DVD-Video zone. Each VTS includes between 3 and 12 files.

[0063] Referring to FIG. 3 for illustrating the VMG and VTS structure, all VOBS are recorded in contiguous blocks. Each VOB includes video, audio and sub-picture data. The VMG includes a video manager information file (VMGI) as control data, video manager menu file of the VOBS (VMGM<sub>1,3</sub>VOBS) and VGMI backup file. Each VTS includes VTSI as control data, a video title set menu of VOBS (VTSM\_VOBS), a video title set title of VOBS (VTSTT\_VOBS) and a VTSI backup file. The VTSTT\_VOBS includes a plurality of cells (C\_IDN). In the drawing, C\_IDN# indicates cell ID number within a VOBS, and VOB\_IDN# VOB ID number within a VOBS.

[0064] Referring to FIG. 4, the VMGI describes information on the related VIDEO\_TS directory. The VMGI starts with a video manager information management table (VMGI\_MAT), followed by a title search pointer table (TT\_SRPT), followed by a video manager menu PGCI unit table (VMGM\_PGCI\_UT), followed by a parental management information table (PTL\_MAINT), followed by a video title set attribute table (VTS\_ATTRT), followed by a text data manager (TXIDT\_MG), followed by a video manager menu cell address table (VMGM\_C\_ADT), followed by a video manager menu video object unit address map (VMGM\_VOBU\_ADMAP).

[0065] Referring to FIG. 5 for describing search information of a video title under the VIDEO\_TS directory, the TT\_SRPT starts with TT\_SRPT information (TT\_SRPTI) followed by title search pointers (TT\_SRP) for every title under the VIDEO\_TS directory. The title number # ranges from 1 to 99.

[0066] Referring to FIG. 6, the VTSI provides information for one or more video titles and the video title set menu (VTSM). The VTSI describes the management information of these titles such as the information to search the part-of title (PTT) and the information to play back the video object set (VOBS), and the video title set menu (VTSM), as well as the information on the attribute of the VOBS.

[0067] The VTSI starts with a video title set information management table (VTSI\_MAT), followed by a video title set part of title search pointer table (VTS\_PTT\_SPRT), followed by a video title set program chain information table (VTS\_PGCIT), followed by a video title set menu PGCI unit table (VTSM\_PGCI\_UT), followed by a video title set time map table (VTS\_TMAPT), followed by a video title set menu cell address table (VTSM\_C\_ADT), followed by a video title set menu video object unit address map (VTSM\_VOBU\_ADMAP), followed by a video title set cell address table (VTS\_C\_ADT), followed by a video title set video object unit address map (VTS\_VOBU\_ADMAP) as shown in FIG. 6.

[0068] Referring to FIG. 7, the VTSI\_MAT describes the start address of each piece of information in the VTSI and the attribute of the VOBS in the VTS. In this VTSI\_MAT, the audio stream attribute table of the VTS (VTS\_AST\_ATTRT) of RBP 516 to 579 stores 8 VTS\_AST\_ATTRs #0



to #7 as shown in FIG. 8A. Each VTS\_AST\_ATR includes 8 bytes arranged as shown in FIG. 8B. Each field value represents the internal information of the audio stream of the VTSM\_VOBS. Describing the contents of one VTS AST ATR with reference to FIG. 8B, the audio coding mode of b63 to b61 is as shown in the following Table 1:

TABLE 1

b63-b61	Audio Coding Mode
000b	Dolby AC-3
010b	MPEG-1 or MPEG-2 without extension bit stream
100b	MPEG-2 with extension bitstream
100b	Linear PCM audio
110b	DTS (option)
111b	SDDS (option)
Others	reserved

[0069] The multichannel extension of b60 is to store information on whether the multichannel extension is made or not. Namely, 0b represents the multichannel extension not selected while 1b represents the multichannel extension selected according to the information of the VTS\_MU\_AST\_ATR recorded in RBP 792 to 983 of the VTSI\_MAT shown in FIG. 7.

[0070] The audio type of b59 to b58 is as shown in Table 2.

TABLE 2

b59-b58	audio type
00b	Not specified
01b	Language included
Others	reserved

[0071] The audio application mode of b57 to b56 is as shown in the following Table 3.

TABLE 3

b57-b56	audio application mode
00b	not specified
01b	Karaoke mode
10b	Surround mode
11b	reserved

[0072] For the quantization /DRC of b55 to b54, when the audio coding mode is '000b', '11 b' is recorded. When the audio coding mode is '010 b' or '011 b', the quantization /DRC is defined as:

[0073] 00b: Dynamic range control data do not exist in MPEG audio stream

[0074] 01b: Dynamic range control data exist in MPEG audio stream

[0075] 10b: reserved

[0076] 11b: reserved

[0077] When the audio coding mode '100b', then the quantization /DRC is defined as in the following Table 4.

TABLE 4

b55-b54	Quantization DRC
00b	16 bits
01b	20 bits
10b	24 bits
11b	reserved

[0078] The sampling frequency fs of b53 to b52 is as shown in Table 5.

TABLE 5

B53-b52	fs
00b	48 KHz
01b	96 KHz
10b	reserved
11b	reserved

[0079] The number of audio channels stored in b50 to b48 is as shown in Table 6.

TABLE 6

b50-b48	No. of Audio Channels
000b	1ch (mono)
001b	2ch (stereo)
010b	3ch (multichannel)
011b	4ch (multichannel)
100b	5ch (multichannel)
101b	6ch (multichannel)
110b	7ch (multichannel)
111b	8ch (multichannel)
Others	reserved

[0080] In addition, the multichannel audio stream attribute table of the VTS of RBP 792 to 983 in the VTSI\_MAT of FIG. 7 provides the VTS\_MU\_AST\_ATRs #0 to #7 of 8 audio streams as shown in FIG. 9A. Each VTS\_MU\_AST\_ATR includes a VTS\_MU\_AST\_ATR (1) of 8 bytes as shown in FIG. 9B and a VTS\_MU\_AST\_ATR (2) of 16 bytes as shown in FIGS. 9C and 9D.

[0081] Thus, the information zone VIDEO\_TS of the DVD-Video is constructed as shown in FIGS. 2 to 9D. Such a DVD-Video stores both video and audio data, and therefore can not provide audio data of good quality. Hence, it is impossible to record the audio data on a DVD-Video at the maximum rate 10.08 Mbps of the DVD. Namely, the maximum bit rate to record the audio data on the DVD-Video is 6.75 Mbps, and the maximum sampling frequency 96 KHz. The linear PCM multichannel audio data recorded on the DVD-Video is as shown in Table 7.

TABLE 7

Fs	Qb	Maximum Number of Channels	Maximum Bit Rate
48 KHz	16 bit	8ch	6.144 Mbps
48 KHz	20 bit	6ch	5.760 Mbps
48 KHz	24 bit	5ch	5.760 Mbps
96 KHz	16 bit	4ch	6.144 Mbps
96 KHz	20 bit	3ch	5.760 Mbps
96 KHz	24 bit	2ch	4.608 Mbps

[0082] The present invention is to provide a DVD-Audio for recording only audio data not including video data. Hence, the DVD-Audio can store multichannel audio data in the range of the maximum bit rate 10.08 Mbps of the DVD, which is different from the DVD-Video. Thus, the DVD-Audio may use the sampling frequency of at most 192 KHz, and extend the number of the audio channels to 13.

[0083] The file structure stored in the information zone of the DVD-Audio is essentially the same as shown in FIG. 1. The files included in the AUDIO\_TS directory are to provide for the DVD-Audio and its player. Hence, the DVD-Audio has both AUDIO\_TS and VIDEO\_TS, where the VIDEO\_TS stores the positional information of the VMG and titles which are reproducible in a DVD-Video player. The AUDIO\_TS stores the positional information of the AMG and titles which are reproducible in a DVD-Audio player. The DVD player determines whether an inserted DVD is DVD-Audio or not by checking the contents of the audio title set directory AUDIO\_TS.

[0084] Referring to FIG. 10, the logical data structure of the DVD-Audio includes structure of a volume space, structure of an audio manager (AMG), structure of an audio title set (ATS), and structure of an audio object set (AOBS). The volume space includes the volume and file structure, a single DVD-Audio zone and DVD others zone. The DVD-Audio zone, which is assigned for the data structure of the DVD-Audio, includes a single AMG and VTSS numbering from at least 1 to a maximum of 99. The AMG is allocated at the leading part of the DVD-Audio zone, including 2 or 3 files. Each VTS includes between 3 and 12 files.

[0085] The AMG and ATS are structured similar to the VMG and VTS of the DVD-Video, as shown in FIGS. 11-17C. However, the data structure for the linear PCM and pseudo-lossless psychoacoustic coded data (PLPCD) of the DVD-Audio is not proper for processing the linear PCM, lossless coded data or PLPCD according to the new sampling frequency of the DVD-Audio. Therefore, the data structures of the AMG and ATS are made somewhat different from that of the VMG and VTS. Namely, the part allocated for the sampling frequency and channel number in the part allocated for the audio attribute of the VMG and VTS is extended for the AMG and ATS.

[0086] Referring to FIG. 11 for illustrating the AMG and ATS structures, all AOBs are recorded in contiguous blocks. The AMG includes an audio manager information file (AMGI) as control data, an audio manager menu file of the AOBs (AMGM\_AOBS) and an AGMI backup file. Each ATS includes ATSI as control data, an audio title set menu of AOBs (ATSM\_AOBS), an audio title set title of AOBs (ATSTT\_AOBS) and an ATSI backup file. The ATSTT\_AOBS includes a plurality of cells (C\_IDN). In the drawing, C\_IDN# indicates cell ID number within an AOBs, and AOB\_IDN# AOB ID number within an AOBs.

[0087] Referring to FIG. 12, the AMGI describes information on the related AUDIO\_TS directory. The AMGI starts with an audio manager information management table

(AMGI\_MAT), followed by a title search pointer table (TT\_SRPT), followed by an audio manager menu PGCI unit table (AMGM\_PGCI\_UT), followed by a parental management information table (PTL\_MAII), followed by an audio title set attribute table (ATS\_ATRT), followed by a text data manager (TXTDT\_MG), followed by an audio manager menu cell address table (AMGM\_C\_ADT), followed by an audio manager menu audio object unit address map (AMGM\_AOBU\_ADMAP).

[0088] Referring to FIG. 13 for describing search information of an audio title under the VIDEO\_TS directory, the TT\_SRPT starts with TT\_SRPT information (TT\_SRPTI) followed by title search pointers (TT\_SRP) for every title under the AUDIO\_TS directory. The title number # ranges from 1 to 99.

[0089] Referring to FIG. 14, the ATSI provides information for one or more audio titles and audio title set menu (ATSM). The ATSI describes the management information of these titles such as the information to search the part\_of title (PTT) and the information to play back the audio object set (AOBS), and the audio title set menu (ATSM), as well as the information on the attribute of the AOBS.

[0090] The ATSI starts with audio title set information management table (ATSI\_MAT), followed by an audio title set part\_of\_title search pointer table (ATS\_PTT\_SPRT), followed by an audio title set program chain information table (ATS\_PGCI), followed by an audio title set menu PGCI unit table (ATSM\_PGCI\_UT), followed by an audio title set time map table (ATS\_TMAPT), followed by an audio title set menu cell address table (ATSM\_C\_ADT), followed by an audio title set menu audio object unit address map (ATSM\_AOBU\_ADMAP), followed by an audio title set cell address table (ATS\_C\_ADT), followed by an audio title set audio object unit address map (ATS\_ADMAP) as shown in FIG. 14.

[0091] Referring to FIG. 15, the ATSI\_MAT describes the start address of each information in the ATSI and the attribute of the AOBS in the ATS. The ATSI\_MAT is provided with ATSM\_AST\_ATR of RBP 260 to 267, ATS\_AST\_ATRT of RBP 516 to 579 and ATS\_MU\_AST\_ATR\_EXT of RBP 792 to 1298.

[0092] The audio coding mode of the ATSM\_AST\_ATR and ATS\_AST\_ATRT stores the coding information of the audio data recorded in the DVD-Audio. The present embodiment describes the recording on the DVD-Audio of the audio data of lossless psychoacoustic coding and pseudo-lossless psychoacoustic coding (hereinafter referred to as "psychoacoustic coding"). In addition, it is assumed that the psychoacoustic coding mode is performed with a DTS coding system, which may support the lossless psychoacoustic coding and pseudo-lossless psychoacoustic coding. In this case, the DTS coding mode is optional, and if b63 to b61 is '110b', the DTS audio coding mode is selected.

[0093] For the change of ATSM\_AST\_ATR, the data pattern and definition of b55 to b48 are changed. Namely, the sampling frequency data of b53 to b52 is changed, and

the reserved bit of b51 is included in the audio channels, as shown in **FIG. 16**. Thus, the audio sampling frequency fs is changed as shown in Table 8.

TABLE 8

b53-b52	b51	fs
00b	0	48 KHz
01b	0	96 KHz
10b	0	192 KHz
11b	0	reserved
00b	1	44.1 KHz
01b	1	88.2 KHz
10b	1	176.4 KHz
11b	1	reserved

[0094] In addition, the number of the audio channels is changed as shown in Tables 9a and 9b.

TABLE 9a

b51-b48	Number of Audio Channels
0000b	1ch (mono)
0001b	2ch (stereo)
0010b	3ch (multichannel)
0011b	4ch (multichannel)
0100b	5ch (multichannel)
0101b	6ch (multichannel)
0110b	7ch (multichannel)
0111b	8ch (multichannel)
1000b	9ch (multichannel)
1001b	10ch (multichannel)
1010b	11ch (multichannel)
1011b	12ch (multichannel)
1100b	13ch (multichannel)
1101b	14ch (multichannel)
1110b	15ch (multichannel)
1111b	16ch (multichannel)

[0095]

TABLE 9b

1100b	13ch (multichannel)
1101b	14ch (multichannel)
1110b	15ch (multichannel)
1111b	16ch (multichannel)

[0096] The **ATS\_AST\_ATRT** of RBP 516 to 579 in the **ATSI\_MAT** as shown in **FIG. 15** stores **ATS\_AST\_ATRs** of 8 audio streams #0 to #7 as shown in **FIG. 17A**, each of which includes 8 bytes structured as shown in **FIG. 17B**, and each field value serves as the internal information of the audio stream of the **ATSM\_AOBS**.

[0097] The data pattern and definition of b55 to b48 are changed as shown in **FIG. 17B**. Namely, in b55 to b48 of the **VTS\_AST\_ATRT** as shown in **FIG. 8B**, the reserved bit of b51 is included in the audio channels. Consequently, the audio sampling frequency fs is changed as shown in Table 8 while the number of the audio channels is changed as shown in Tables 9a and 9b.

[0098] In the **ATS\_MU\_AST\_ATRT**, the information as shown in **FIGS. 18B and 18C** are added to the information

of **FIGS. 9B and 9C**. The **ATS\_MU\_AST\_ATR(1)** and **ATS\_MU\_AST\_ATR(2)** provide the information on the audio data and channel mixing coefficients up to 8 channels, and therefore can not provide the information on the linear PCM audio over 8 channels. The present invention may provide up to 13 channels, so that the information from the 9th channel to the 13th channel are recorded in the reserved regions after the **ATS\_MU\_AST\_ATR(1)** and **ATS\_MU\_AST\_ATR(2)**. Referring to **FIG. 18A**, the **ATS\_MU\_AST\_ATRT** provides 13 **ATS\_MU\_AST\_ATRs** #0 to #12 each having 39 bytes to store the information on 13 audio channels and the mixing coefficients.

[0099] Each **ATS\_MU\_AST\_ATR** includes the audio channel information as shown in **FIG. 18B** and the mixing coefficient information as shown in **FIG. 18C**. **FIG. 18B** illustrates only the information of the extended five audio channels **ATS\_MU\_AST\_ATR\_EXT(1)**, while omitting the **ATS\_MU\_AST\_ATR(1)** for storing the data information of the 8 audio channels. Likewise, **FIG. 18C** illustrates only the information of the extended five audio channels **ATS\_MU\_AST\_ATR\_EXT(2)**, while omitting the **ATS\_MU\_AST\_ATR(2)** for storing the data information of the 8 audio channels.

[0100] The **ATSI\_MAT** represents the information on the audio data recorded on the DVD-Audio, forming the first part of each audio title and followed by the **AOBS** of substantial audio data. Of course, the **VTSI\_MAT** as shown in **FIG. 7** represent also the information on the video data, sub-picture data and audio data recorded on the DVD-Video, forming the first part of each video title and followed by the **VOBS** of substantial data. The **AOBS** is structured as shown in **FIG. 19**, providing a plurality of audio packs to store the audio data. Likewise, the **VOBS** is structured similar to **FIG. 19**, providing a plurality of video packs, sub-picture packs and audio packs to respectively store the video data, sub-picture data and audio data.

[0101] The structure of the **AOBS** is similar to that of the **VOBS**, and therefore description of the structure of the **VOBS** will help understand the structure of the **AOBS**. The **VOBS** includes a plurality of video objects **VOB\_IDN1** to **VOB\_IDNi**, each of which in turn includes a plurality of cells **C\_IDN1** to **C\_IDNj**, each of which in turn includes a plurality of video object units **VOBUs**, each of which in turn includes a plurality of video packs.

[0102] The video data recorded in a DVD-Video includes a plurality of packs, whose structure is illustrated in **FIG. 20** without a padding packet. Referring to **FIG. 20**, one pack has a size of 2048 bytes including a pack header of 14 bytes and a plurality of packets for video, audio, sub-picture, **DSI** or **PCI** of 2034 bytes. Further, the packet header includes a pack start code of 4 bytes, **SCR** of 6 bytes, **program\_mux\_rate** of 3 bytes and **stuffing\_length** of 1 byte.

[0103] Referring to **FIG. 21A**, the linear PCM audio pack includes a pack header of 14 bytes and a linear audio packet of 2034 bytes. The audio packet includes a packet header of 1 byte, **sub\_stream\_id** of 1 byte, audio frame information of 3 bytes and linear PCM audio data of 1 to 2013 bytes.

[0104] Referring to FIG. 21B, the dolby AC-3 audio pack includes a pack header of 14 bytes and a dolby AC-3 audio packet of 2034 bytes. The audio packet further includes a packet header of 1 byte, sub\_stream\_id of 1 byte, audio frame information of 3 bytes and AC-3 audio data of 1 to 2016 bytes.

[0105] FIG. 21C illustrates the structure of an MPEG-1 or MPEG-2 audio pack without an extension bit stream, and FIG. 21D the structure of MPEG-2 with an extension stream. The structures of the audio packs as shown in FIGS. 21A to 21D are shown in Table 10, additionally provided with private data areas corresponding to their formats.

data area besides the common data area is as shown in Table 11.

TABLE 11

Field	Bit	Byte	Value	Comment
sub_stream_id	8	1	10100***b	Note 1
number_of_frame_headers	8			Note 2
first_access_unit_pointer	16			Note 3
audio_emphasis_flag	1			Note 4
audio_mute_flag	1			Note 5

TABLE 10

Field	Bit	Byte	Value	Comment
packet_start_code_prefix	24	3	00 0001h	
stream_id	8	1	1011 1101b	private_stream_1
PES_packet_length	16	2		
'10'	2	3		
PES_scrambling_control	2	3	00b	not scrambled
PES_priority	1	3	0	no priority
data_alignment_indicator	1	3	0	not defined by descriptor
copyright	1	3	0	not defined by descriptor
original_or_copy	1	3	1 or 0	original: 1 copy: 0
PTS_DTS_flags	2	3	10 or 00b	
ESCR_flag	1	3	0	no ESCR field
ES_rate_flag	1	3	0	no EST rate field
DSTM_trick_mode_flag	1	3	0	no trick mode field
additional_copy_info_flag	1	3	0	no copy info field
PES_CRC-flag	1	3	0	no CRC field
PES_extension_flag	1	3	0 or 1	
PES_header_data_length	8	3	0 to 15	
'0010'	4	5	provider defined	Note 1
PTS[32 . . . 30]	3	5	provider defined	Note 1
marker_bit	1	5	provider defined	Note 1
PTS[29 . . . 15]	15	5	provider defined	Note 1
marker_bit	1	5	provider defined	Note 1
PTS[14 . . . 0]	15	5	provider defined	Note 1
marker_bit	1	5	provider defined	Note 1
PES_private_data_flag	1	1	0	Note 2
pack_header_field_flag	1	1	0	Note 2
program_packet_sequence_counter_flag	1	1	0	Note 2
P_STD_buffer_flag	1	1	1	Note 2
reserved	3	1	111b	Note 2
PES_extension_flag_2	1	1	0	Note 2
'01'	2	2	01b	Note 2
P_STD_buffer_scale	1	2	1	Note 2
P_STD-buffer_size	13	2	58	Note 2
stuffing_byte	—	0-7		

In Table 10, Notes 1 and 2 are described as follows:

Note 1: "PTS[32 . . . 0]" shall be described in every audio packet in which the first sample of an audio frame is included.

Note 2: These fields occur in the first audio packet of each VOB, and are prohibited in the subsequent audio packets.

[0106] In Table 10, Notes 1 and 2 are described as follows:

[0107] Note 1: "PTS[32 . . . 0]" shall be described in every audio packet in which the first sample of an audio frame is included.

[0108] Note 2: These fields occur in the first audio packet of each VOB, and are prohibited in the subsequent audio packets.

[0109] In the audio packet of the linear PCM data structured as shown in FIG. 21A, the data recorded in the private

TABLE 11-continued

Field	Bit	Byte	Value	Comment
Reserved	1	3	0	
audio_frame_number	5			Note 6
quantization_word_length	2			Note 7
audio sampling frequency	2			Note 8
Reserved	1	3	0	

TABLE 11-continued

Field	Bit	Byte	Value	Comment
number_of_audio_channels	3		Provider Defined	Note 9
dynamic_range_control	8			Note 10
Audio Data Area (Linear PCM)				

In Table 11, Notes 1 to 10 are described as follows:

Note 1: \*\*\*represents decoding an audio data stream number.

Note 2: "number\_of\_frame\_headers" describes the number of audio frames whose first byte is in this audio packet.

Note 3: The access unit is the audio frame. The first access unit is the first audio frame which has the first byte of the audio frame.

Note 4: "audio\_emphasis\_flag" describes the state of emphasis. When "audio\_sampling\_frequency" is 96 KHz, "emphasis off" is described in this field. The emphasis is applied to all audio samples decoded from the first access unit.

0b: emphasis off

1b: emphasis on

Note 5: "audio\_mute\_flag" describes the state of mute while all data in the audio frame is ZERO. The mute is applied to all audio samples decoded from the first access unit.

Note 6: "audio\_frame\_number" describes the frame number of the first access unit in the Group of audio frame (GOF) with the numbers between '0' and '19'.

Note 7: "quantization\_word\_length" describes the word-length which the audio samples are quantized to.

00b: 16 bits

01b: 20 bits

10b: 24 bits

11b: reserved

Note 8: "audio\_sampling\_frequency" describes the sampling frequency of the audio sample.

00b: 48 KHz

01b: 96 KHz

Others: reserved

Note 9: "number\_of\_channels" describes the number of audio channels.

000b: 1ch (mono)

001b: 2ch (stereo)

010b: 3ch

011b: 4ch

100b: 5ch

101b: 6ch

110b: 7ch

111b: 8ch

Note 10: "dynamic\_range\_control" describes the dynamic word control word to compress the dynamic range from the first access unit.

[0110] In Table 11, Notes 1 to 10 are described as follows:

[0111] Note 1: \*\*\* represents decoding an audio data stream number.

[0112] Note 2: "number\_of\_frame\_headers" describes the number of audio frames whose first byte is in this audio packet.

[0113] Note 3: The access unit is the audio frame. The first access unit is the first audio frame which has the first byte of the audio frame.

[0114] Note 4: "audio\_emphasis\_flag" describes the state of emphasis. When "audio\_sampling\_frequency" is 96 KHz, "emphasis off" is described in this field. The emphasis is applied to all audio samples decoded from the first access unit.

[0115] 0b: emphasis off

[0116] 1b: emphasis on

[0117] Note 5: "audio\_mute\_flag" describes the state of mute while all data in the audio frame is ZERO. The mute is applied to all audio samples decoded from the first access unit.

[0118] Note 6: "audio\_frame\_number" describes the frame number of the first access unit in the Group of audio frame (GOF) with the numbers between '0' and '19'.

[0119] Note 7: "quantization\_word\_length" describes the word-length which the audio samples are quantized to.

[0120] 00b: 16 bits

[0121] 01b: 20 bits

[0122] 10b: 24 bits

[0123] 11b: reserved

[0124] Note 8: "audio\_sampling\_frequency" describes the sampling frequency of the audio sample.

[0125] 00b: 48KHz

[0126] 01b: 96KHz

[0127] Others: reserved

[0128] Note 9: "number\_of\_channels" describes the number of audio channels.

[0129] 000b: 1ch (mono)

[0130] 001b: 2ch (stereo)

[0131] 010b: 3ch

[0132] 011b: 4ch

[0133] 100b: 5ch

[0134] 101b: 6ch

[0135] 110b: 7ch

[0136] 111b: 8ch

[0137] Note 10: "dynamic\_range\_control" describes the dynamic word control word to compress the dynamic range from the first access unit.

[0138] In the audio packets as shown in FIGS. 21A to 21D, the stream\_id of the linear PCM audio packet is 1011 1101b (private\_stream\_1), and the sub\_stream\_id 1010 0\*\*\*b. The stream\_id of the AC-3 audio packet is 1011 1101b (private\_stream\_1), and the sub\_stream\_id 1000 0\*\*\*b. The stream\_id of the MPEG audio packet is 1100 0\*\*\*b or 1101 0\*\*\*b, and no sub\_stream\_id. "\*\*\*\*" in the stream\_id or sub\_stream\_id indicates the decoding audio stream number which has a value between "0" and "7", and the decoding audio stream numbers are not assigned the same number regardless of the audio compression mode.

[0139] FIG. 22 illustrates the structure of the audio stream and packs. The audio data used in the DVD-Audio may include linear PCM data, dolby AC-3 data and MPEG audio data. The audio stream further includes a plurality of audio packs. In addition, each audio pack constitutes a unit of 2048 bytes as shown in FIG. 22. In this case, the form of encoding the linear PCM audio is based on Table 12.

TABLE 12

Sampling frequency (fs)	48 KHz	96 KHz
Sampling phase	Shall be simultaneous for all channels in a stream	
Quantization mpbasis	16 bits or more, 2's complementary code Can be applied (zero point: 50 μs, pole: 15 μs)	Can not be applied

[0140] In Table 12, the audio stream data for linear PCM includes contiguous GOFs (Group of Audio Frames), each of which includes 20 audio frames except for the last GOF. The last GOF includes no more than 20 audio frames.

[0141] FIG. 23 illustrates the structure of the audio frame. One audio frame includes sample data which correspond to the presentation time of 1/600 second. One audio frame contains 80 or 160 audio sample data according to a frequency (fs) of 48 KHz or 96 KHz. One GOF corresponds to the presentation time of 1/30 second.

[0142] FIGS. 24A to 24C illustrate a sample data alignment for linear PCM. Sample data is formed by the data from each channel sampled out at the same time. Therefore, the size of sample data varies with the audio stream attribute. The sampled data is continuously arranged. Two sample data for each mode are shown in FIGS. 24A to 24C. FIG. 24A illustrates a 16 bits mode, FIG. 24B illustrates a 20 bits mode and FIG. 24C illustrates a 24 bits mode. The packet data structure of the linear PCM audio is as shown in Table 13.

TABLE 13

Stream mode			Data in a Packet			
Number of channels	fs (KHz)	Quantization	Maximum number of samples in a packet	Data size (byte)	Packet stuffing of first/other PES packet (byte)	Padding packet for first/other PES packet (byte)
					1 mono	48/96
2 stereo	48/96	20	804	2010	0/3	0/0
	48/96	24	670	2010	0/3	0/0
	48/96	16	502	2008	2/5	0/0
3	48/96	20	402	2010	0/3	0/0
	48/96	24	334	2004	6/0	0/9
	48/96	16	334	2004	6/0	0/9
4	48/96	20	268	2010	0/3	0/0
	48	24	222	1988	0/0	12/15
	48/96	16	250	2000	0/0	10/13
5	48	20	200	2000	0/0	10/13
	48	24	166	1992	0/0	18/21
	48	16	200	2000	0/0	10/13
6	48	20	160	2000	0/0	10/13
	48	24	134	2010	0/3	0/0
	48	16	166	1992	0/0	18/21
7	48	20	134	2010	0/3	0/0
	48	16	142	1988	0/0	22/25
8	48	16	124	1984	0/0	26/29

[0143] If the number of samples is less than in Table 13, the length of a padding packet may increase to adjust the pack size. Samples shall be aligned at packet boundary. Namely, the audio sample data of every audio packet for linear PCM audio always start with the first byte of S<sub>2n</sub> described in Table 13. The channel assignment for linear PCM is as follows:

[0144] In the stereo presentation mode, the descriptions of channels, ACH0 and ACH1 correspond to left channel (L-ch) and right channel (R-ch) respectively. Multichannel coding is required to keep compatibility with the stereo mode.

[0145] The structure of the DVD-Audio is as shown in FIG. 19. Since the DVD-Audio is to store audio data, it contains no video pack (V\_PCK) or sub-picture pack (SP\_PCK), or otherwise only small amounts of them. The AOBS includes a plurality of packs of data as the VOBS does. The general structure of the audio pack is as shown in FIGS. 20 and 21A to 21D. It is assumed that the inventive DVD-Audio does not employ MPEG and AC-3 and instead records audio data of linear PCM and compression coding system.

[0146] Tables 10 and 11 illustrate the linear PCM audio packet of the DVD-Video, which may be altered to obtain the linear PCM audio packet of the DVD-Audio. Describing the linear PCM system of the DVD-Audio, the sampling frequencies are 48, 44.1, 96, 188.2, 192 or 176.4 KHz, the number of quantization bits is 16, 20 or 24 bits, and the number of audio channels is from 1 ch to the maximum allowed by the bit rate. The number of the audio channels may be determined by Eq. 1.

$$N = \frac{Mby}{Fs * Qb} \tag{Eq. 1}$$

[0147] Fs: Sampling Frequency(Hz)→48 KHz, 44.1 KHz, 96 KHz, 88.2 KHz, 192 KHz, or 176.4 KHz

[0148] Qb: Number of Quantization Bits→16 bits, 20 bits, or 24 bits

[0149] Mby: Maximum Data Transfer Rate of DVD-(Mbps)→10.08 Mbps

[0150] N: Maximum Number of Possible Channels Determined by Data Transmission Rate, Sampling Frequency and Number of Quantization Bits of DVD.

[0151] The number of channels determined by Eq. 1 is shown in Table 14.

TABLE 14

Sampling Frequency	Number of Quantization Bits	Maximum Number of Channels
48 KHz/44.1 KHz	16 bits	8
48 KHz/44.1 KHz	20	8
48 KHz/44.1 KHz	24	8
96 KHz/88.2 KHz	16	6
96 KHz/88.2 KHz	20	5
96 KHz/88.2 KHz	24	4
192 KHz/176.4 KHz	16	3
192 KHz/176.4 KHz	20	2
192 KHz/176.4 KHz	24	2

[0152] The structure of the linear PCM audio pack of the DVD-Audio is constructed as shown in FIG. 25, which is the same as that of the DVD-Video as shown in FIG. 21A. Namely, one audio pack comprises a pack header of 14 bytes

and one or more linear PCM packets of at maximum 2021 bytes. The pack header is based on an MPEG2 system layer.

[0153] The structure of the linear PCM audio packet is also based on the MPEG2 system layer. The linear PCM audio packet is constructed as shown in Tables 15 and 16. Table 15 has the same structure as Table 10 while Table 16 for representing private data structure has a structure different from that of Table 11.

TABLE 15

Field	Bit	Byte	Value	Comment
packet_start_code_prefix	24	3	00 0001h	
stream_id	8	1	1011 1101b	private_stream_1
PES_packet_length	16	2		
'10'	2	3		
PES_scrambling_control	2	3	00b	not scrambled
PES_priority	1	3	0	no priority
data_alignment_indicator	1	3	0	not defined by descriptor
copyright	1	3	0	not defined by descriptor
original_or_copy	1	3	1 or 0	original: 1 copy: 0
PTS_DTS_flags	2	3	10 or 00b	
ESCR_flag	1	3	0	no ESCR field
ES_rate_flag	1	3	0	no EST rate field
DSTM_trick_mod_flag	1	3	0	no trick mode field
additional_copy_info_flag	1	3	0	no copy info field no CRC field
PES_CRC_flag	1	3	0	field
PES_extension_flag	1	3	0 or 1	
PES_header_data_length	8	3	0 to 15	
'0010'	4	5	provider defined	Note 1
PTS[32 . . . 30]	3	5	provider defined	Note 1
marker_bit	1	5	provider defined	Note 1
PTS[29 . . . 15]	15	5	provider defined	Note 1
marker_bit	1	5	provider defined	Note 1
PTS[14 . . . 0]	15	5	provider defined	Note 1
marker_bit	1	5	provider defined	Note 1
PES_private_data_flag	1	1	0	Note 2
pack_header_field_flag	1	1	0	Note 2
program_packet_sequence_counter_flag	1	1	0	Note 2
P_STD_buffer_flag	1	1	1	Note 2
reserved	3	1	111b	Note 2
PES_extension_flag_2	1	1	0	Note 2
'01'	2	2	01b	Note 2
P_STD_buffer_scale	1	2	1	Note 2
P_STD_buffer_size	13	2	58	Note 2
Stuffing_byte	—	0-7		

[0154]

TABLE 16

Field	Bit	Byte	Value	Comment
sub_stream-id	8	1	10100***b	Note 1
number_of_frame_headers	8		Provider defined	Note 2

TABLE 16-continued

Field	Bit	Byte	Value	Comment
first_access_unit_pointer	16		Provider defined	Note 3
audio_emphasis_flag	1		Provider defined	Note 4
audio_mute_flag	1		Provider defined	Note 5

TABLE 16-continued

Field	Bit	Byte	Value	Comment
reserved	1	3	0	
audio_frame_number	5		Provider defined	Note 6
quantization_word_length	2		Provider defined	Note 7

TABLE 16-continued

Field	Bit	Byte	Value	Comment
audio_sampling_frequency	3		Provider defined	Note 8
number_of_audio_channels	3		Provider defined	Note 9
dynamic_range_control	8		Provider defined	Note 10

Audio data Area (Linear PCM)

In Table 16, Notes 1 to 10 are described as follows:

Note 1: \*\*\*represents decoding the audio data stream number.

Note 2: "number\_of\_frame\_headers" describes the number of audio frames whose first byte in this audio packet.

Note 3: The access unit is the audio frame. The first access unit is the first audio frame which has the first byte of the audio frame.

Note 4: "audio\_emphasis\_flag" describes the state of emphasis. When "audio\_sampling\_frequency" is 96 KHz, "emphasis off" is described in this field. The emphasis is applied to all audio samples decoded from the first access unit.

0b: emphasis off

1b: emphasis on

Note 5: "audio\_mute\_flag" describes the state of mute while all data in the audio frame is ZERO. The mute is applied to all audio samples decoded from the first access unit.

0b: mute off

1b: mute on

Note 6: "audio\_frame\_number" describes the frame number of the first access unit in the Group of audio frame (GOF) with the numbers between '0' and '19'.

Note 7: "quantization\_word\_length" describes the word-length which the audio samples are quantized to.

00b: 16 bits

01b: 20 bits

10b: 24 bits

11b: reserved

Note 8: "audio\_sampling\_frequency" describes the sampling frequency of the audio sample.

00b: 48 KHz

01b: 96 KHz

10b: 192 KHz

11b: reserved

100b: 44.1 KHz

101b: 88.2 KHz

110b: 176.4 KHz

111b: reserved

Note 9: "number\_of\_channels" describes the number of audio channels.

0000b: 1ch (mono)

0001b: 2ch (stereo)

0010b: 3ch

0011b: 4ch

0100b: 5ch

0101b: 6ch

0110b: 7ch

0111b: 8ch

(multichannel)

Note 10: "dynamic\_range\_control" describes the dynamic word control word to compress the dynamic range from the first access unit.

[0155] In Table 16, Notes 1 to 10 are described as follows:

[0156] Note 1: \*\*\* represents decoding the audio data stream number.

[0157] Note 2: "number\_of\_frame\_headers" describes the number of audio frames whose first byte is in this audio packet.

[0158] Note 3: The access unit is the audio frame. The first access unit is the first audio frame which has the first byte of the audio frame.

[0159] Note 4: "audio\_emphasis\_flag" describes the state of emphasis. When "audio\_sampling\_frequency" is 96 KHz, "emphasis off" is described in this field. The emphasis is applied to all audio samples decoded from the first access unit.

[0160] 0b: emphasis off

[0161] 1b: emphasis on

[0162] Note 5: "audio\_mute\_flag" describes the state of mute while all data in the audio frame is ZERO. The mute is applied to all audio samples decoded from the first access unit.

[0163] 0b: mute off

[0164] 1b: mute on

[0165] Note 6: "audio\_frame\_number" describes the frame number of the first access unit in the Group of audio frame (GOF) with the numbers between '0' and '19'.

[0166] Note 7: "quantization\_word\_length" describes the word-length which the audio samples are quantized to.

[0167] 00b: 16 bits

[0168] 01b: 20 bits

[0169] 10b: 24 bits

[0170] 11b: reserved

[0171] Note 8: "audio\_sampling\_frequency" describes the sampling frequency of the audio sample.

[0172] 00b: 48 KHz

[0173] 01b: 96 KHz

[0174] 10b: 192 KHz

[0175] 11b: reserved

[0176] 100b: 44.1 KHz

[0177] 101b: 88.2 KHz

[0178] 110b: 176.4 KHz

[0179] 111b: reserved

[0180] Note 9: "number\_of\_channels" describes the number of audio channels.

[0181] 0000b: 1ch (mono)

[0182] 0001b: 2ch (stereo)

[0183] 0010b: 3ch

[0184] 0011b: 4ch

[0185] 0100b: 5ch

[0186] 0101b: 6ch

[0187] 0110b: 7ch

[0188] 0111b: 8ch

[0189] Note 10: "dynamic\_range\_control" describes the dynamic word control word to compress the dynamic range from the first access unit.

[0190] The packet data structure of the linear PCM audio and corresponding frame size of 48 KHz/192 KHz are as shown in Table 17.



TABLE 17

Stream Mode			Data in a Packet			
Number of Channels	Fs (KHz)	Quantization	Maximum number of samples in a packet	Data size (byte)	Packet Stuffing of first/other PES packet (byte)	Padding packet for first/other PES packet (byte)
1 mono	48/96/192	16	1004	2008	2/5	0/0
	48/96/192	20	804	2010	0/3	0/0
2 stereo	48/96/192	24	670	2010	0/3	0/0
	48/96/192	16	502	2008	2/5	0/0
	48/96/192	20	402	2010	0/5	0/0
3	48/96/192	24	334	2004	6/0	0/9
	48/96/192	16	334	2004	6/0	0/9
	48/96	20	268	2010	0/3	0/0
4	48/96	24	222	1988	0/0	12/15
	48/96	16	250	2000	0/0	10/13
	48/96	20	200	2000	0/0	10/13
5	48/96	24	166	1992	0/0	18/21
	48/96	16	200	2000	0/0	10/13
	48/96	20	160	2000	0/0	10/13
6	48	24	134	2010	0/3	0/0
	48/96	16	166	1992	0/0	18/21
	48	20	134	2010	0/3	0/0
7	48	24	110	1980	0/0	30/33
	48	16	142	1988	0/0	22/25
	48	20	114	1995	0/0	15/18
8	48	24	94	1974	0/0	36/39
	48	16	124	1984	0/0	26/29
	48	20	100	2000	0/0	10/13
9	48	24	82	1968	0/0	42/45
	48	16	110	1980	0/0	30/33
	48	20	88	1980	0/0	30/33
10	48	16	100	2000	0/0	10/13
	48	20	80	2000	0/0	10/13
	48	16	90	1980	0/0	30/33
11	48	16	82	1968	0/0	42/45
12	48	16	76	1976	0/0	34/37
13	48	16	76	1976	0/0	34/37

[0191] If the number of samples is less than in Table 17, the length of padding packet may increase to adjust the pack size. Samples shall be aligned at the packet boundary. Namely, the audio sample data of every audio packet starts with the first byte of  $S_{2n}$ . The number of the audio samples in a packet always becomes even.

[0192] Thus, in DVD-Audio format, the linear PCM data is processed in frames and GOF. The DVD-Audio may use the sampling frequency of 192 KHz, whereby the basic rule of linear PCM coding may be set as shown in Table 18.

TABLE 18

Sampling frequency (fs)	48 KHz/44.1 KHz	96 KHz/88.2 KHz	192 KHz/176.4 KHz
Sampling Phase	Shall be simultaneous for all channels in all streams		
Quantization	16 bits or more, 2's complementary code		
Emphasis	Can be applied		cannot be applied
	(zero point: 50 $\mu$ s, pole: 15 $\mu$ s)		

[0193] One audio frame contains 320 audio sample data when fs is 192 KHz. One GOF corresponds to the presentation time of  $1/30$  second as in the DVD-Video. The sampling frequency of 96 KHz is used to achieve multichannel to store quality audio data.

[0194] When recording the linear PCM audio data using the sampling frequency of 48 KHz and quantization of 16 bits, 13 channels are available so as to record the audio data

of 10 channels required by the present multichannel music. However, when using the sampling frequency of 192 KHz and quantization of 24 bits, only 2 channels are available to record audio data, which can not meet the requirement of the multichannel music. Namely, it is impossible to achieve multichannel audio function with high sampling frequency and a great number of data bits. However, such limitation may be resolved by lossless coding or pseudo-lossless coding. The compression ratio of lossless coding is about 2:1 while that of pseudo-lossless psychoacoustic coding is about 4:1.

[0195] It is assumed that the inventive DVD-Audio employs DTS (Digital Theater System) coding which is pseudo-lossless psychoacoustic coding with the compression ratio of about 4:1. Further, the DTS makes it possible to perform lossless coding. The DTS can provide a sufficient number of channels without significant degradation of sound quality. For the DTS may carry out coding for a high specification with the sampling frequency of 192 KHz and 24 bit quantization compared to different compression coding algorithms presently proposed, and has been developed to minimize degradation of sound quality instead of reducing the bit rate. The DTS has the sampling frequencies of 48 KHz, 44.1 KHz, 96 KHz, 88.2 KHz, 192 KHz or 176.4 KHz, the quantization bit number of 16, 20 and 24, and the number of channels from 1ch coding to the maximum allowed by the bit rate. The number of audio channels may be determined by Eq. 2.

$$N = \frac{Mby * Ccy}{Fs * Qb}$$

Eq. 2

[0196] Fs: Sampling Frequency(Hz)→48 KHz, 44.1 KHz, 96 KHz, 88.2 KHz, 192 KHz, or 176.4 KHz

[0197] Qb: Number of Quantization Bits→16, 20, or 24

[0198] Mby: Maximum Data Transfer Rate of DVD-(Mbps)→10.08 Mbps

[0199] Ccy: Compression ratio of Pseudo-Lossless Psychoacoustic Coding

[0200] N: Maximum Number of Audio Channels Determined by Data Transfer Rate, Sampling Frequency and Number of Quantization Bits of DVD

[0201] Assuming the DTS coding with the compression ratio of 4:1 is used for compression coding, the number of channels determined by Eq. 2 is as shown in Table 19. Therefore, in accordance with Eq. 2, each sampling frequency can support 8 or more channels.

TABLE 19

Sampling Frequency	Number of Quantization Bits	Maximum Number of Channels
48 KHz/44.1 KHz	16 bits	52
48 KHz/44.1 KHz	20	42
48 KHz/44.1 KHz	24	35
96 KHz/88.2 KHz	16	26
96 KHz/88.2 KHz	20	21
96 KHz/88.2 KHz	24	17
192 KHz/176.4 KHz	16	13
192 KHz/176.4 KHz	20	10
192 KHz/176.4 KHz	24	8

[0202] Thus, the inventive DVD-Audio is constructed based on the structure of the MPEG2 system layer, and therefore, the compression coded audio pack structure comprises a pack header of 14 bytes and compression coded audio packets each having at maximum 2021 bytes, as shown in FIG. 26. The pack header meets the specification of MPEG2 system layer.

[0203] The structure of the compression coded audio packet is also based on the specification of MPEG2 system layer. The compression coded audio packet is constructed as shown in Tables 20 and 21. The Table 20 has the same structure as Table 10 presenting the structure of linear PCM audio packet of the DVD-Video.

TABLE 20

Field	Bit	Byte	Value	Comment
packet_start_code_prefix	3	3	00 0001h	
stream_id	8	1	1011 1101b	private_stream_1
PES_packet_length	16	2		
'10'	2	3		
PES_scrambling_control	2	3	00b	not scrambled
PES_priority	1	3	0	no priority
data_alignment_indicator	1	3	0	not defined by descriptor
copyright	1	3	0	not defined by descriptor
original_or_copy	1	3	1 or 0	original: 1 copy:0
PTS_DTS_flags	2	3	10 or 00b	
ESCR_flag	1	3	0	no ESCR field
ES_rate_flag	1	3	0	no EST rate field
DSTM_trick_mode_flag	1	3	0	no trick mode field
additional_copy_info_flag	1	3	0	no copy info field
PES_CRC_flag	1	3	0	no CRC field
PES_extension_flag	1	3	0 or 1	
PES_header_data_length	8	3	0 to 15	
'0010'	4	5	provider defined	Note 1
PTS [32. . .30]	3	5	provider defined	Note 1
marker_bit	1	5	provider defined	Note 1
PTS [29. . .15]	15	5	provider defined	Note 1
marker_bit	1	5	provider defined	Note 1
PTS [14. . .0]	15	5	provider defined	Note 1
marker_bit	1	5	0	Note 1
PES_private_data_flag	1	1	0	Note 2
pack_header_field_flag	1	1	0	Note 2
program_packet_sequence_counter_flag	1	1	0	Note 2

TABLE 20-continued

Field	Bit	Byte	Value	Comment
P_STD_buffer_flag	1	1	1	Note 2
reserved	3	1	111b	Note 2
PES_extension_flag_2	1	1	0	Note 2
'01'	2	2	01b	Note 2
P_STD_buffer_scale	1	2	1	Note 2
P_STD_buffer_size	13	2	58	Note 2
stuffing_byte	—		0-7	

[0204]

TABLE 21

Field	Bit	Byte	Value	Comment
sub_stream_id	8	1	&&&& &***b	Note 1
number_of_frame_headers	8	1	Provider Defined	Note 2
first_access_unit_pointer	16	2	Provider Defined	Note 3

DTS Audio data area

[0205] In Table 21, Notes 1 to 3 are described as follows:

[0206] Note 1: "sub\_stream\_id" varies with the compression coding system, and so becomes "1000 1\*\*\*b" with the DTS. "\*\*\*\*" represents decoding the audio data stream number.

[0207] Note 2: "number\_of\_frame\_headers" describes the number of audio frames whose first byte is in this audio packet.

[0208] Note 3: The access unit is the audio frame. The first\_access\_unit is the first audio frame which has the first byte of the audio frame.

[0209] Thus, the DVD-Audio is provided with more than 8 channels to perform the compression coding, available sampling frequencies of 48 KHz, 44.1 KHz, 96 KHz, 88.2 KHz, 192 KHz or 176.4 KHz, quantization bit number of 16, 20 or 24, compression ratio from 1:1 to over 5:1, down mixing, dynamic range control and time stamp.

[0210] The DTS compression algorithm used in the present embodiment has a compression ratio low enough to provide significantly improved sound quality, and may optionally be employed in DVD-Video. The DVD-Video has the structures of DTS pack and packet and restricted items for DTS. For the restricted items, the bit rate after compression is limited up to 1.5 Mbps and the sampling frequency for compressible data is only 48 KHz. However, in the inventive DVD-Audio employing the DTS algorithm, the sampling frequency is extended to 192 KHz, quantization bit number to 24 bits, multichannel data compressed to about 4:1, thereby providing desirable sound quality. Namely, the compression coding used in the inventive DVD-Audio employs sampling frequencies of 48 KHz/44.1 KHz/96 KHz/88.2 KHz/192 KHz/176.4 KHz and quantization bit number of 16 bits/20 bits/24 bits so as to compress multichannel linear PCM data by about 4:1 without degrading sound quality.

[0211] The DVD-Audio may additionally include VIDEO\_TS and VMG for the information region in a

structure which is the same as in the DVD-Video in order to have compatibility with a DVD-Video player. However, the DVD-Video restricts the data transfer rate of an audio stream within 6.144 Mbps, as shown in Table 11.

TABLE 22

	Transfer Rate		
	Total Streams	One Stream	Note
VOB	10.08 Mbps	—	
Video Streams	9.80 Mbps	9.80 Mbps	Number of Streams=1
Audio Streams	9.80 Mbps	6.144 Mbps	Number of Streams=8(max)
Sub-picture Streams	9.80 Mbps	3.36 Mbps	Number of Streams=32(max)

[0212] Hence, the DVD-Video player may reproduce only the data satisfying the DVD-Video specification among the audio data of the DVD-Audio. The linear PCM data reproduced by the DVD-Video player is as shown in Table 7. Of course, compression coded DTS data is played by the DVD-Video player to reproduce only DTS streams specified by the DVD-Video. For example, it is assumed that the titles to be stored into a DVD are as shown in Table 23.

TABLE 23

Sampling Frequency	Number of Quantization Bits	Number of Channels	Remark
48 KHz	16	8ch	Title 1
96 KHz	16	4ch	Title 2
96 KHz	24	2ch	Title 3
96 KHz	24	4ch	Title 4
192 KHz	24	2ch	Title 5

[0213] Then, the VIDEO\_TS and VMG are recorded with the attribute and position information of Titles 1 to 3 but not with the information of Titles 4 and 5. On the contrary, the AUDIO\_TS and AMG of the DVD-Audio are recorded with the information of all the Titles 1 to 5 because the Titles 1 to 3 meet the specifications of both DVD-Video and DVD-Audio but the Titles 4 and 5 only meet the specification of the DVD-Audio. Hence, the Titles 4 and 5 may be played only by the DVD-Audio player. If there is an available space in the data zone, the Titles 4 and 5 may be separately recorded in the available data space with the sampling frequency, quantization bit number and channel number reduced, and the information on the Titles 4 and 5 are stored into the VIDEO\_TS and VMG. Then, the Titles 4 and 5 may be reproduced by a DVD-Video player.

[0214] If the compression coding DTS does not meet the specification of the DVD-Video concerning data transfer rate, number of channels, sampling frequency of original data, quantization bit number, etc., the information is recorded only in the AUDIO\_TS and AMG but not in the VIDEO\_TS and VMG. Namely, only the DTS streams satisfying the specification of the DVD-Video may be recorded in the VIDEO\_TS and VMG. In order to reproduce the DTS streams not conforming to the specification of the DVD-Video, they must be coded to meet the transfer rate, number of channels, sampling frequency and quantization bit number specified for the DVD-Video, stored to be recorded in the VIDEO\_TS and VMG.

[0215] The AMG and ATSI\_MAT of the DVD-Audio has the same structure as the VMG and VTSI of the DVD-Video. However, the audio data exceeding the specification of the DVD-Video such as sampling frequency of 192 KHz and 8 or more channels must be changed to be reproduced by the DVD-Video player. Hence, the disk is made as follows:

[0216] When the content of a title to be recorded on the disk is within the specification of the DVD-Video, any one of the VMG and the AMG is kept to make the VIDEO\_TS and AUDIO\_TS direct the file through the VMG or AMG. Then, the DVD-Audio player regards the file as AMG to play while the DVD-Video player regards the file as VMG to play.

[0217] Meanwhile, if any of the titles to be recorded in the disk has an audio stream which does not meet the specification of the DVD-Video, both the VMG and the AMG are kept together, and the VMG is not recorded with the information on the titles which do not conform to the specifications of the DVD-Video. Of course, the AMG has not recorded with the information on the titles which have the sampling frequency, number of quantization bits and number of channels altered to be compatible with the DVD-Video player.

[0218] However, when the AMG and ATSI\_MAT of the DVD-Audio are structured entirely different from the VMG and VTSI\_MAT of the DVD-Video, both VMG and AMG must be prepared, and thus both VTSI\_MAT and ATSI\_MAT. Of course, the VMG and VTSI\_MAT are provided with the information on the audio titles conforming to the specification of the DVD-Video.

[0219] The apparatus for playing the DVD-Audio may be designed independently from the DVD-Video player, but the inventive DVD-Audio player may be combined with the DVD-Video player.

[0220] Referring to FIG. 27 for illustrating the structure of a DVD-Audio player, a system controller 111 controls the whole operation of the DVD-Audio player, serving the user interface. The system controller 111 determines whether the inserted disk is a DVD-Video or DVD-Audio by checking effective data included in the VIDEO\_TS and AUDIO\_TS directory. When it is checked that effective data exists from the AUDIO\_TS directory, the system controller 111 determines the inserted disk to be a DVD-Audio and thus, controls its playing operation. But if it is determined that no effective data exists from the AUDIO\_TS, the system controller 111 determines the inserted disk to be a DVD-Video, and thus, stops the playing operation.

[0221] A pickup device 112 is provided to read the data stored in the DVD-Audio. A servo controller 113 controls

the pickup device 112 to perform various servo functions under the control of the system controller 111. A data receiver 114 analyzes and corrects an error occurring in the data output from the pickup device 112, and includes an error correction circuit. An audio decoder 115 transfers the audio information from the data receiver 114 to the system controller 111, decoding received audio data under the control of the system controller 111.

[0222] The audio decoder 115 is designed to decode the linear PCM audio data and compression coded audio data according to the present invention, as shown in FIG. 28. Referring to FIG. 28, an input data buffer 211 stores the audio data output from the data receiver 114. A stream selector 212 selectively outputs the audio data stream from the input buffer 211 under the control of the system controller 111. A linear PCM decoder 213 decodes linear PCM audio data received from the stream selector 212 to the original audio data. A coding data decoder (Pseudo-Lossless Psychoacoustic Decoding Circuit) 214 decodes compression coded data from the stream selector 212 to the original audio data. An output buffer 215 stores the audio data delivered by the decoding parts 213 and 214. A digital audio formatter 216 converts the audio data from the decoding parts 213 and 214 into a format specified by the system controller 111. The timing controller 210 generates timing control signals to control the operations of the parts of the audio decoder 115 under the control of the system controller 111.

[0223] A digital processor (High-bit High-sampling Digital Filter) 116 filters audio data from the audio decoder 115 under the control of the system controller 111. An audio output circuit (High Performance Digital to Analog Converters and Analog Audio Circuitry) 117 converts the audio data from the digital processor 116 into an analog signal.

[0224] Referring to FIGS. 27 and 28, the data receiver 114 transfers the audio data reproduced from a DVD-Audio through the pickup device 112 to the audio decoder 115. The reproduced audio data are sequentially stored into the input buffer 211 of the audio decoder 115. The audio data stored in the input buffer 211 are selected by the stream selector 212 and transferred to the decoding parts 213 and 214. Namely, when the system controller 111 demands decoding of the linear PCM audio data, the stream selector 212 transfers the audio data stored in the input buffer 211 to the linear PCM decoder. In addition, when the system controller 111 demands decoding of the compression coded data, the stream selector 212 transfers the audio data stored in the input buffer to the coding data decoder 214.

[0225] Describing the decoding operation of the linear PCM audio data, the linear PCM decoder 213 generally performs multichannel downmixing, sampling frequency conversion and requantization of the input signal. For example, when 8-channel data produced from the stream selector 212 is required to be converted into 2-channel data, the linear PCM decoder 213 performs multichannel downmixing to produce an output of the required channel number. Further, when the input data sampled at 192 KHz is required by the system controller 111 to be converted into data sampled at 96 KHz, the linear PCM decoder 213 performs the sampling frequency conversion to produce audio data of the required sampling frequency. In addition, when the input audio data of 24 bit quantization is required by the system controller 111 to be converted into data of 16 bit quantiza-

tion, the linear PCM decoder 213 performs the requantization process to produce audio data of the required number of bits.

[0226] Describing the decoding operation of the compression coded audio data, the coding data decoder 214 decodes the compression coded audio data by carrying out the corresponding algorithm under the control of the system controller 111. In this case, the form of the audio data produced from the coding data decoder 214 is specified by the system controller 111. In the present embodiment, the coding data decoder 214 may be a DTS decoder. In addition, the coding data decoder 214 also carries out the multichannel downmixing, sampling frequency conversion and requantization of the input signal together with the algorithm decoding.

[0227] The audio data decoded by the decoding parts 213 and 214 is transferred to the output buffer 215 and digital audio formatter 216. The output buffer 215 stores the decoding audio data to synchronize with a control signal supplied by the timing controller 210. The digital audio formatter 216 adjusts the decoded audio data to the transmission format between the digital devices, synchronizing it with a control signal from the timing controller 210. In this case, the output audio data may be delivered to an audio/video system or a computer having the same transmission format.

[0228] The decoded audio data from the audio decoder 115 is processed through the digital processor 116 and converted by the audio output circuit 117 into an analog signal. The digital processor 116 comprises a plurality of digital filters to eliminate noises outside the audio signal band. The digital processor 116 requires a filter coefficient having a much higher resolution and number of taps than the digital filters used in the conventional DVD or CD to process the audio data sampled at 192 KHz and quantized by 24 bits. Of course, when a D/A converter of 96 KHz and 192 KHz becomes commonly available, the digital processor 116 may be included in the D/A converter. The audio output circuit 117 includes a plurality of D/A converters to convert the audio data deprived of noises into an analog audio signal.

[0229] Referring to FIG. 29 for illustrating an apparatus for playing both DVD-Video and DVD-Audio, the system controller 311 controls the whole operation of the DVD-Audio/Video player, serving the user interface. The system controller 311 determines whether the inserted disk is a DVD-Video or DVD-Audio by checking effective data included in the VIDEO\_TS and AUDIO\_TS directory. When there is effective data from the AUDIO\_TS directory, the system controller 311 determines the inserted disk to be a DVD-Audio and thus, controls its playing operation. But if there is no effective data from the AUDIO\_TS, the system controller 311 determines the inserted disk to be a DVD-Video, stops the present DVD-Audio playback mode, and changes to the playback mode of the DVD-Video.

[0230] A pickup device 312 is provided to read the data stored in the DVD-Audio. A servo controller 313 controls the pickup device 312 to perform various servo functions under the control of the system controller 311. A data receiver 314 analyzes and corrects an error occurring in the data output from the pickup device 312, and includes an error correction circuit. An audio/video decoder 315 transfers the audio information from the data receiver 314 to the

system controller 311, decoding received audio data under the control of the system controller 311.

[0231] The audio/video decoder 315 is designed to decode video data and audio data, as shown in FIG. 30. Referring to FIG. 30, an input data buffer 411 stores the audio and video data output from the data receiver 314. A stream parser 412 selectively outputs the audio and video data stream from the input buffer 411 under the control of the system controller 311. An audio decoding circuit 413 decodes the audio data selected by the stream parser 412 in response to a control data from the system controller 311. A decoding audio output circuit 414 outputs the decoded audio data from the audio decoding circuit 413. A video decoding circuit 415 decodes the video data selected by the stream parser 412 in response to a control signal of the system controller 311. A decoding video output circuit 416 outputs the decoded video data from the video decoding circuit 415. A timing controller 410 generates timing control signals to control the operations of the parts of the audio/video decoder 315 under the control of the system controller 311.

[0232] The audio decoding circuit 413 must be provided with decoding elements corresponding to a linear PCM system, an MPEG system, an AC-3 system and a compression coding system. The linear PCM system and compression coding system require additional elements to reproduce the audio data recorded in the inventive DVD-Audio. Namely, the decoding elements are provided to reproduce the audio data formed by sampling frequency, quantization bits and audio channels according to the present invention. Also provided is a stream selector to distribute the audio data corresponding to the decoding elements.

[0233] A digital processor (High-bit High-sampling Digital Filter) 316 filters audio data from the audio/video decoder 315 under the control of the system controller 311. An audio output circuit (High Performance Digital to Analog Converters and Analog Audio Circuitry) 117 converts the audio data from the digital processor 316 into an analog signal. A video output circuit (NTSC Encoder Video Digital to Analog Converter's Analog Video Circuitry) 318 encodes video data from the audio/video decoder 315 in NTSC, converting the video data into an analog video signal.

[0234] Referring to FIGS. 29 and 30, the data reproduced from the disk through the pickup device 312 is transferred to the data receiver 314 to analyze it and correct an error in it, and is applied to the audio/video decoder 315. The data produced from the data receiver 314 is applied to the input buffer 411 of the audio/video decoder 315. The stream parser 412 selects a required stream according to a control data of the system controller 311, and analyzes the stream to deliver the video data to the video decoding circuit 415 and the audio data to the audio decoding circuit 413.

[0235] The audio decoding circuit 413 transforms the audio data from the stream parser 412 according to the requirements of the system controller 311. The audio decoding circuit 413 must include the decoding functions to decode audio data of both DVD-Video and DVD-Audio. The video decoding circuit 415 decodes and transforms the input video data. The video data transformation means sub\_title process, pan\_scan, etc.

[0236] The decoded audio and video data are respectively transferred to the decoding audio and video output circuits

414 and 416, and are finally transmitted outside in synchronism with timing control signals of the timing controller 410. The decoding audio output circuit 414 adjusts the decoded audio data to the transmission format between the digital devices. The audio data generated from the decoding audio output circuit 414 is transferred to a different audio/video system or computer.

[0237] As shown in FIG. 29, the audio/video decoder 315 follows the specification of the DVD-Video when processing video signals, and carries out both the inventive algorithm and the audio decoding algorithm according to the specification of the DVD-Video. Thus, the audio decoding circuit 413 contains the linear PCM and DTS algorithms of the audio specification of the DVD-Video, and therefore both DVD-Video and DVD-Audio may be reproduced.

[0238] In this case, the algorithm required for the audio decoding of the DVD-Video indicates linear PCM decoding(1)+AC-3 decoding+MPEG decoding while the algorithm required for the audio decoding of the DVD-Audio indicates linear PCM decoding(2)+coding data decoding (Pseudo-Lossless Psychoacoustic Decoding). Hence, the linear PCM algorithm in the DVD-Video is included in the linear PCM algorithm according to the present invention. The decoding algorithm employed in the DVD-Video and DVD-Audio includes the functions as expressed by Eq. 3, carried out by the audio decoding circuit

$$\text{Audio Decoder} = \text{Linear PCM Decoder(2)} + \text{Pseudo-Lossless Psychoacoustic Decoder} + \text{AC-3 Decoder} + \text{MPEG Decoder.} \quad \text{Eq. 3}$$

[0239] Thus, such an apparatus for playing both DVD-Video and DVD-Audio detects the VIDEO\_TS and AUDIO\_TS of the inserted DVD to set the audio decoding mode. The audio data of the DVD-Audio with the video data eliminated is shown in Table 24.

TABLE 24

Sampling Frequency	Number of Quantization Bits	Bit Rate per Channel	Number of Channels	Required Data Capacity
48 KHz	16 bits	768 Kbps	8ch	5.99 Gbyte
	20 bits	960 Kbps	8ch	5.76 Gbyte
	24 bits	1.152 Mbps	8ch	5.53 Gbyte
96 KHz	16 bits	1.536 Mbps	6ch	5.53 Gbyte
	20 bits	1.920 Mbps	5ch	5.76 Gbyte
	24 bits	2.304 Mbps	4ch	5.53 Gbyte

[0240] The compression coding system specified in the DVD-Video may compress data at a maximum of 448 Kbps. The sampling frequency to allow compression is 48 KHz, and the number of quantization bits to allow compression is 16 bits. Hence, the amount of data to be handled is limited, and the compression ratio is about 10:1. Therefore, it is unsuitable for audio data, especially in view of sound quality. If the compression algorithm is a dolby AC-3 algorithm, the quantization system is 16 bit linear PCM, the sampling frequency is 48 KHz, the maximum number of channels to record at is a maximum of 6ch (one of the audio channels having a subwoofer channel containing audio data below 200 Hz and using 0.1 of that channel), and possible bit rate is 192 Kbps-448 Kbps. The dolby AC-3 algorithm is very limited in the number of quantization bits, the sampling frequency, and the high compression ratio, resulting in

serious degradation of sound quality and is thus unsuitable for audio use exclusively. In addition, when the compression algorithm is MPEG2 algorithm, the quantization system is 16 bits-24 bits linear PCM, the sampling frequency is 48 KHz, the maximum number of channels to record is 8ch (one of the audio channels having a subwoofer channel containing audio data below 200 Hz and using 0.1 of that channel), and the possible bit rate is 64 Kbps-912 Kbps. This algorithm has a high quantization bit number for possible coding and a high channel number to record, but the sampling frequency is limited and the compression ratio high, thereby causing degradation of sound quality.

[0241] However, assuming that the transfer rate is 10.08 Mbps and the time for reproducing is 80 minutes for the DVD-Audio, the linear PCM audio is achieved as shown in Table 25. Furthermore, even in the case that the sampling frequency is 44.1 KHz, 88.2 KHz and 176.4 KHz, the PCM audio may have similar values as those shown in Table 25.

TABLE 25

Sampling Frequency	Number of Quantization Bits	Bit Rate per Channel	Number of Channels	Required Data Capacity
48 KHz	16 bits	768 Kbps	13ch	5.99 Gbyte
	20 bits	960 Kbps	10ch	5.76 Gbyte
	24 bits	1.152 Mbps	8ch	5.53 Gbyte
96 KHz	16 bits	1.536 Mbps	6ch	5.53 Gbyte
	20 bits	1.920 Mbps	5ch	5.76 Gbyte
	24 bits	2.304 Mbps	4ch	5.53 Gbyte
192 KHz	16 bits	3.072 Mbps	3ch	5.53 Gbyte
	20 bits	3.840 Mbps	2ch	4.61 Gbyte
	24 bits	4.608 Mbps	2ch	5.53 Gbyte

[0242] Employing DTS in the compression coding system, the quantization uses 16 bit, 20 bit or 24 bit linear PCM, a sampling frequency of 48 KHz, 44.1 KHz, 96 KHz, 88.2 KHz, 192 KHz or 176.4 KHz, the maximum number of channels to record is 13ch, and the compression ratio is about 4:1. The DTS compression coding has a high quantization bit number and sampling frequency with a reduced compression ratio, keeping high sound quality.

[0243] As described above with reference to FIGS. 27 and 29, the audio or audio/video player determines the kind of DVD by checking if effective data is stored in the AUDIO\_TS directory. Namely, the DVD-Audio player performs the reproducing function or not according to whether is effective data stored in the AUDIO\_TS directory. The audio/video player as shown in FIG. 29 performs the audio or video playing function according to whether effective data stored in the AUDIO\_TS directory.

[0244] FIG. 31 describes the operation of the inventive concept with reference to the audio/video player as shown in FIG. 29. An inserted DVD is checked by the system controller 311 in steps 511, and the content of the AUDIO\_TS directory is read in step 513. In step 515, it is checked whether there is effective data stored in the AUDIO\_TS directory. If the inserted DVD is a DVD-Video, there is no effective data in the AUDIO\_TS directory. Namely, the DVD-Video has the AUDIO\_TS directory, but it is empty. However, if the inserted DVD is a DVD-Audio, the AUDIO\_TS directory contains the information on the positions of the audio data as shown in FIGS. 10 to 18C.

[0245] Detecting effective data in the AUDIO\_TS directory in step 515, the system controller 311 determines the inserted disk as being a DVD-Audio in step 517. In step 519, the position of the AMG as shown in FIGS. 10 and 11 is located by reading the AUDIO\_TS directory. Then, the pickup device 312 is moved to the position of the AMG in the DVD in step 521, where the AMG is read to confirm the information on the places storing the entire audio data. As shown in FIGS. 10 and 11, the AMG contains the information on all audio titles stored in the DVD-Audio as well as the attribute and position information of each title.

[0246] In step 523, the system controller 311 checks whether there is a demand for reproducing a specific audio title. The demand is made by the user or a command stored in the DVD-Audio. Detecting the demand to reproduce a title, the system controller 311 locates the position of the title in the disk according to the position information obtained from the AMG in step 525, and in step 527, moves the pickup device 312 to the position of the ATSI\_MAT of the title to read it. In step 529, the information of the ATSI\_MAT as shown in FIGS. 15 to 18C is analyzed to determine the reproducing algorithm by discovering the kind and attribute of the audio title to play. In step 531, the audio decoding circuit 413 of the audio/video decoder 315 is set to the selected audio data from the DVD-Audio according to the reproducing algorithm. The information required to set the audio decoding circuit 413 are the audio coding mode, the sampling frequency, the quantization bit number and the channel number. Finally, the selected title is decoded by the audio decoding circuit 413 played in step 533.

[0247] On the other hand, if there is no effective data in the AUDIO\_TS directory in step 515, the system controller 311 determines the inserted disk as being a DVD-Video, and in step 537, the position of the VMG is located by reading the VIDEO\_TS directory. Then, the pickup device 312 is moved to the position of the VMG in the DVD in step 539, where the VMG is read to confirm the information on the places storing the entire video data. Thereafter, if there is a demand to reproduce a title, the video, sub-picture and audio data of the selected title are played according to the information stored in the VTSI\_MAT.

[0248] Likewise, a DVD-Audio player, which only reproduces data from a DVD-Audio, also performs the steps 511 to 533 for the DVD-Audio, but stops the playing operation for a DVD-Video.

[0249] After setting the audio decoding circuit 413 according to the information stored in the ATSI\_MAT, the system controller 311 analyzes the audio pack stored in the data area of a DVD-Audio from step 533 going through the steps as shown in FIG. 32.

[0250] In step 611, the system controller 311 commands a decoding operation of the audio decoding circuit 413, and in step 613, controls the stream parser 412 to transfer the received audio data to the audio decoding circuit 413 provided with the corresponding audio algorithm. Then, the audio decoding circuit 413 decodes the received audio data according to the algorithm set by the system controller 311. Here, the system controller 311 checks the operational state of the audio decoding circuit 413 in step 615. Detecting an abnormal state of the audio decoding circuit, the process proceeds to step 621 to control the decoding circuit 413 to stop the decoding operation, and the stream parser 412 is

controlled to stop transferring data. Then, after performing the repair algorithm according to the abnormal state, the process is returned to step 611.

[0251] However, if the audio decoding circuit 413 performs the decoding operation normally in step 615, the decoded audio data is output through the decoding audio output circuit 414 in step 617. Thereafter, the operational state of the audio decoding circuit 413 is checked again in step 619. Detecting the abnormal state, the process proceeds to the step 621, or otherwise the process is returned to decode the next audio data. When the audio stream is fully decoded by the audio decoding circuit 413, the system controller 311 controls the digital processor 316 and audio output circuit 317 to convert the decoded audio data into an analog signal.

[0252] Thus, the inventive DVD includes a VIDEO\_TS and AUDIO\_TS directory to make it possible to distinguish a DVD-Audio from a DVD-Video by checking effective data stored in the AUDIO\_TS directory. The DVD-Audio may be recorded with the audio data sampled at a maximum of 192 KHz and quantized by 24 bits. Further, audio channels may be extended greatly. Therefore, by reproducing the audio data in the DVD audio, it is possible to reproduce an audio signal of high quality which is suitable for multi-channel music. The number of channels limited by the data transfer speed, the sampling frequency and the quantization bit number is extended by using a coding algorithm.

[0253] In the case where the linear PCM data sampled at the sampling frequency of 192 KHz is divided into the linear PCM data of 96 KHz and the data of 192 KHz so that the data of 96 KHz is recorded by the lossless psychoacoustic coding, the DVD of the present invention records the audio titles at the sampling frequency of 192 KHz in the AUDIO\_TS directory by linear PCM lossless coding, and records the video titles at the sampling frequency of 96 KHz in the VIDEO\_TS directory by linear PCM coding. The DVD-audio player reads the AUDIO\_TS to demodulate the data by the lossless psychoacoustic coding, and mixes it with the data of 96 KHz to reproduce it into the data of 192 KHz. The DVD-video player reads the VIDEO\_TS directory to reproduce the data of 96 KHz. That is, by recording one title into the AUDIO\_TS and VIDEO\_TS separately, the DVD-audio player may reproduce the data at 192 KHz and the DVD-video player may reproduce the data at 96 KHz.

[0254] Furthermore, in the case where the music data sampled at the 44.1 KHz for an existing CD is provided to the DVD, the music data of 44.1 KHz should be converted into the music data of 48 KHz in order to provide it by using the conventional DVD-video format. Undesirably, however, the audio data may be degraded during the conversion. The DVD according to the present invention can support the audio frequency sampled at 44.1 KHz in DVD-audio format. Thus, it is possible to record the audio data as it is without conversion of the sampling frequency and provide it together with the video data, thereby providing the audio sound of high quality.

[0255] Preferably, a general DVD-video player should be connected to the DVD-audio player which can reproduce the 24-bit data of 192 KHz, since the general DVD-video has a specification inferior to that of the DVD-audio.

What is claimed is:

1. A DVD-Audio disk having a data area comprising a DVD-Audio zone, the DVD-Audio zone comprising:

an audio title (ATS) comprises audio title set information (ATSI) followed by contiguous audio objects (AOBs); and

an audio manager (AMG) comprising information on said ATS, wherein

the ATSI includes audio stream attributes, each audio stream attribute indicates an audio coding mode,

a first, second, or third quantization bit number corresponding to the data to be reproduced,

a first, second, third, fourth, fifth, or sixth sampling frequency corresponding to the data to be reproduced, and

decoding algorithm information relating to a number of audio channels of the data to be reproduced, and

each of said AOBs includes audio packs recorded with audio data corresponding to the decoding algorithm stored in the audio stream attribute.

2. The DVD-Audio disk as claimed in claim 1, wherein the audio coding mode is linear pulse code modulated (PCM) audio, the first through third quantization bit numbers are respectively 16 bits, 20 bits and 24 bits, and the first through sixth sampling frequencies are respectively 48 KHz, 96 KHz, 192 KHz, 44.1 KHz, 88.2 KHz, and 176.4 KHz.

3. The DVD-Audio disk as claimed in claim 1, wherein the audio coding mode is a compression coding system, the first through third quantization bit numbers of the audio data before compression are respectively 16 bits, 20 bits and 24 bits, and the first through sixth sampling frequencies are respectively 48 KHz, 96 KHz, 192 KHz, 44.1 KHz, 88.2 KHz, and 176.4 KHz.

4. The DVD-Audio disk as claimed in claim 1, wherein the first through sixth sampling frequencies comprise at least two sampling frequencies above 100 KHz.

5. The DVD-Audio disk as claimed in claim 1, wherein two of the first through sixth sampling frequencies comprise 192 KHz and 176.4 KHz.

6. The DVD-Audio disk as claimed in claim 1, wherein said AMG comprises

audio manager information (AMGI) having control data for said ATS, and

an audio manager menu file for the AOBs of said ATS.

7. The DVD-Audio disk as claimed in claim 6, wherein said AMG further comprises a backup file of the AMGI.

8. The DVD-Audio disk as claimed in claim 1, wherein said ATS further comprises:

an audio title set menu of the AOBs, and

an audio title set title of the AOBs comprising cells of data, pluralities of the cells comprising the AOBs.

9. The DVD-Audio disk as claimed in claim 8, wherein said ATS further comprises a backup file of the ATSI.

10. The DVD-Audio disk as claimed in claim 1, wherein the ATSI further comprises value fields, wherein the first through sixth sampling frequencies are indicated by corresponding states of two of the value fields.

11. The DVD-Audio disk as claimed in claim 10, wherein one of the two value fields indicates whether the sampling frequency is above 100 KHz.

12. The DVD-Audio disk as claimed in claim 10, wherein one of the two value fields indicates whether the sampling frequency is one of 176.4 KHz and 192 KHz.

13. The DVD-Audio disk as claimed in claim 11, wherein the other of the two value fields has a state that indicates the sampling frequency is 176.4 KHz or 192 KHz.

14. The DVD-Audio disk as claimed in claim 1, wherein if the audio coding mode is linear pulse code modulated (PCM) audio, a maximum number of the audio channels is determined by the following equation:

$$N = \frac{Mby}{Fs * Qb},$$

where  $F_s$  is the sampling frequency(Hz),  $Q_b$  is the quantization bit number,  $Mby$  is a maximum data transfer rate (Mbps) of the DVD-Audio disk, and  $N$  is the maximum number of the audio channels determined by the data transfer rate, the sampling frequency, and the quantization bit number of the DVD-Audio disk.

15. The DVD-Audio disk as claimed in claim 1, wherein if the audio coding mode is a compression coding system, a maximum number of the audio channels is determined by the following equation:

$$N = \frac{Mby * Ccy}{Fs * Qb},$$

where  $F_s$  is the sampling frequency (Hz),  $Q_b$  is the quantization bit number,  $Mby$  is a maximum data transfer rate (Mbps) of the DVD-Audio disk,  $Ccy$  is a compression ratio according to a DTS compression coding system, and  $N$  is the maximum number of the audio channels determined by the data transfer rate, the sampling frequency, and the quantization bit number of the DVD-Audio disk.

16. The DVD-Audio disk as claimed in claim 1, wherein if the audio coding mode is linear pulse code modulated (PCM) audio, the first through third quantization bit numbers are respectively 16 bits, 20 bits and 24 bits, the fourth to sixth sampling frequencies are respectively 44.1 KHz, 88.2 KHz and 176.4 KHz, a maximum number of the audio channels is 8, and the number of the audio channels is determined by the following equation:

$$N = \frac{Mbr}{Fs * Qb},$$

where  $F_s$  is the sampling frequency (Hz) of the data to be reproduced,  $Q_b$  is the quantization bit number (bits) of the data to be reproduced,  $Mbr$  is a maximum data transfer rate (Mbps) of the DVD-Audio disk,  $N$  is a maximum number of recording channels as determined by the maximum data transfer rate, the sampling frequency and the quantization bit number of the DVD-Audio disk.



17. The DVD-Audio disk as claimed in claim 1, wherein if the audio coding mode is pseudo lossless compression coding, the first through third quantization bit numbers of the data to be reproduced before compression are respectively 16 bits, 20 bits and 24 bits, the fourth to sixth sampling frequencies are respectively 44.1 KHz, 88.2 KHz and 176.4 KHz, a maximum number of the audio channels 8, and the number of the audio channels is determined by the following equation:

$$N = \frac{Mbr * Ccr}{Fs * Qb},$$

where Fs is the sampling frequency (Hz) of the data to be reproduced, Qb is the quantization bit number (bits) of the data to be reproduced, Mbr is a maximum data transfer rate (Mbps) of the DVD-Audio disk, Ccr is a compression ratio according to a DTS compression coding system, and N is a maximum number of recording channels determined by the maximum data transfer rate, the sampling frequency and the quantization bit number of the DVD-Audio disk.

18. The DVD-Audio disk as claimed in claim 1, wherein if the audio coding mode is linear pulse code modulated (PCM) audio, the first through third quantization bit numbers are respectively 16 bits, 20 bits and 24 bits, the first through sixth sampling frequencies are respectively 48 KHz, 44.1 KHz, 96 KHz, 88.2 KHz, 192 KHz and 176.4 KHz, and a maximum number of the audio channels is 8, and a number of recording channels is determined by the following equation:

$$N = \frac{Mbr}{Fs * Qb},$$

where Fs is the sampling frequency (Hz), Qb is the quantization bit number (bits), Mbr is a maximum data transfer rate (Mbps) of the DVD-Audio disk, and N is a maximum number of the recording channels determined by the maximum data transfer rate, the sampling frequency and the quantization bit number of the DVD-Audio disk.

19. A DVD-Audio disk having a data area comprising a DVD-Audio zone to be reproduced by a decoder, the DVD-Audio zone comprising

an audio title (ATS); and

an audio manager (AMG) comprising information on said ATS,

wherein said ATS comprises control information followed by contiguous audio objects (AOBs) including audio data, the control information including decoding information corresponding to the data to be reproduced, indicates to the decoder both a quantization bit number, and a sampling frequency, which is differentiated from two sampling frequencies above 100 KHz.

20. The DVD-Audio disk as claimed in claim 19, wherein the sampling frequency information is contained in first and second value fields, where

a first state of the first value field indicates whether the sampling frequency is one of 48 khz, 96 khz, or 192 khz, and

a second state of the first value field indicates whether the sampling frequency is one of 44.1 Khz, 88.2 Khz, and 176.4 Khz.

21. The DVD-Audio disk as claimed in claim 19, wherein a state of the second value field indicates, with the first state of the first value field, that the sampling frequency is 192 khz, and with the second state of the first value field, that the sampling frequency is 176.4 Khz.

\* \* \* \* \*