

(19) World Intellectual Property Organization
International Bureau



(43) International Publication Date
8 March 2001 (08.03.2001)

PCT

(10) International Publication Number
WO 01/15989 A1

- (51) International Patent Classification⁷: **B65D 41/16**
- (21) International Application Number: PCT/US00/40796
- (22) International Filing Date: 31 August 2000 (31.08.2000)
- (25) Filing Language: English
- (26) Publication Language: English
- (30) Priority Data:
09/386,702 31 August 1999 (31.08.1999) US
- (71) Applicant: **CAPITOL SPECIALTY PLASTICS, INC.**
[US/US]; 2039 McMillan Street, Auburn, AL 36832 (US).
- (72) Inventor: **BUCHOLTZ, Michael**; 8314 Bliestein Road,
Colden, NY 14033 (US).
- (74) Agent: **SCHINDLER, Barry, J.**; Dreier & Bartiz LLP,
499 Park Avenue, New York, NY 10022 (US).
- (81) Designated States (*national*): AU, BR, CA, JP, MX, NO,
NZ.
- (84) Designated States (*regional*): European patent (AT, BE,
CH, CY, DE, DK, ES, FI, FR, GB, GR, IE, IT, LU, MC,
NL, PT, SE).
- Published:**
— With international search report.
— Before the expiration of the time limit for amending the
claims and to be republished in the event of receipt of
amendments.
- For two-letter codes and other abbreviations, refer to the "Guidance Notes on Codes and Abbreviations" appearing at the beginning of each regular issue of the PCT Gazette.*

(54) Title: A LEAK PROOF, RESEALABLE CONTAINER AND CAP ASSEMBLY

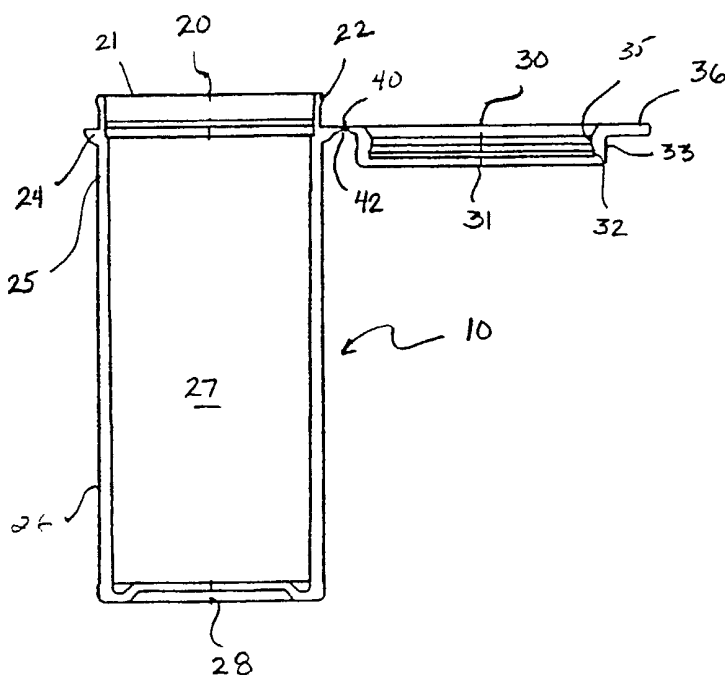

(57) Abstract: A leakproof, resealable container and cap assembly (10), consisting essentially of a container (20) having a rim (22) at its upper portion and a cap (30) having a circular base (31) with an outer periphery, a cylindrical tubular skirt (33) having an inner wall with at least one recess (32), a thumb tab (36) for facilitating the opening and closing of the container (20), and a hinge (40) connecting the cap (30) to the container; and in a closed position, the skirt (33) of the cap (30) overlies the container (20) and the rim (22) of the container (30) is situated within the recess (32) of the inner wall of the skirt (33) of the cap (30).



WO 01/15989 A1

1 A LEAK PROOF, RESEALABLE CONTAINER AND CAP ASSEMBLY

2 **BACKGROUND OF THE INVENTION:**

3 It is desirable to provide a container that can be opened, sealed, or resealed using
4 a frontal, singular motion and that can still produce a leakproof seal. For example, during
5 laboratory applications such as drug testing, users of the containers desire the accessibility and
6 resealability of the specimen by simply using frontal thumb pressure upon the thumb tab of the
7 container to result in a leakproof container. In addition to ease to use, the integrity of the
8 specimens in the containers is significant in ensuring proper chain of custody requirements of the
9 container contents.

10 **SUMMARY OF THE INVENTION:**

11 The present invention relates to a leakproof and resealable container and cap
12 assembly. In one embodiment of the present invention, the assembly comprises a cap and container
13 attached by a hinge. The container has an upper portion and an outer surface, and at the upper
14 portion, the container has a rim. The cap has a circular base with an outer periphery and a
15 cylindrical tubular skirt extending perpendicularly and outwardly around said outer periphery of
16 the base; the skirt has an inner wall which includes at least one recess. In another embodiment, the
17 cap has opposing ends; the cap has a thumb tab for facilitating the opening and closing of the
18 container and the hinge attached to the container. The thumb tab and hinge are positioned on
19 opposing ends of the cap and extend perpendicularly and outwardly from the skirt of the cap. In
20 a further embodiment, the skirt of the cap overlies the container and the rim of the container is
21 situated within the recess of the inner wall of the skirt of the cap during a closed position.

22 In yet another embodiment, the container further comprises a flange (i.e. an anti-
23 decapping ring that serves to prevent the cap from being unintentionally opened and also serves
24 as a visual scale to assure uniform cap position around the flange) projecting radially outwardly
25 from the outer surface of the container. In still another embodiment, the hinge is attached to the
26 container flange and the skirt of the cap is designed to overlie the rim of the container and be in
27 uniform close proximity to the container flange during the closed position.

28 In a further embodiment, the cap and container assembly, in a closed position, forms
29 an air tight seal.

30 In another embodiment, the cap and container are molded of plastic. In yet another
31 embodiment, the cap and container are integrally molded of the plastic to form a hinge
32 therebetween. In still another embodiment, the cap is fit to the container during the closed position
33 to form a leakproof, air tight seal.

34 In a further embodiment, the hinge of the assembly has a recess. The recess forms
35 two elements, the first element being attached to the skirt of the cap and the second element being
36 attached to the container. In still a further embodiment, the recess functions as a bending point
37 during the opening and closing of the container.

1 The present invention also relates to a method of manufacturing a leakproof
2 resealable container and cap assembly, comprising: providing a container and cap connected by a
3 hinge, the container has an upper portion and an outer surface, the container includes a rim at the
4 upper portion; the cap has a circular base with an outer periphery and a cylindrical tubular skirt
5 extending perpendicularly and outwardly around the outer periphery of the base, the skirt has an
6 inner wall having at least one recess; the cap has opposing ends, the cap including a thumb tab; the
7 tab and hinge is positioned on opposing ends of the cap and extend perpendicularly and outwardly
8 from the skirt of the cap; and closing the container by applying, in a singular motion, a frontal,
9 downward pressure upon the thumb tab to allow the skirt to overlie the container and the rim of
10 the container to be situated within the recess of the inner wall of the skirt of the cap.

11 **BRIEF DESCRIPTION OF THE DRAWINGS:**

12 A more complete appreciation of the present invention and many of the attendant
13 advantages thereof will be readily understood by reference to the following description when
14 considered in connection with the accompanying drawings in which:

15 FIGURE 1 is a longitudinal sectional view of one embodiment through the
16 leakproof, resealable container and cap assembly in accordance with the present invention;

17 FIGURE 2 is an overhead plan view of one embodiment of the container and the
18 cap connected by the hinge in an opened position;

19 FIGURE 3 is a side elevation view of one embodiment of the container and cap
20 assembly of the present invention in a closed position;

21 FIGURE 4 is a cross-sectional side view of one embodiment of the assembly in a
22 closed position; and

23 FIGURE 5 is a detailed blow-up showing a portion of the cap and container of one
24 embodiment of the container and cap assembly of the present invention with measurements and
25 angles.

26 Among those benefits and improvements that have been disclosed, other objects and
27 advantages of this invention will become apparent from the following description taken in
28 conjunction with the accompanying drawings. The drawings constitute a part of this specification
29 and include exemplary embodiments of the present invention and illustrate various objects and
30 features thereof.

1 **DETAILED DESCRIPTION OF THE PRESENT INVENTION:**

2 The present invention relates to a leakproof and resealable container and cap
3 assembly. The term "resealable" means that the container can be opened/reopened and
4 closed/reclosed a numerous amount of times. The term "leakproof" means that the container
5 passes the blue crystal dye test. The blue crystal dye test is a visual test to detect leaks within a
6 container seal. A container "passes" the blue crystal dye test if the white paper, in which the
7 container is placed on, does not visually change color (i.e. The white paper does not become
8 contaminated with the blue crystal dye liquid from the container). The blue crystal dye test
9 procedure consists of the following : (a) the blue crystal dye liquid is prepared by adding one
10 teaspoon of blue crystal dye powder to one gallon of alcohol and the thoroughly mixing the solution;
11 (b) the blue crystal dye liquid is poured into the container (i.e. a sufficient amount of the dye liquid
12 must be added so, when the container is placed upside down, the entire seal area must be covered);
13 (c) the container is closed by applying, in a singular motion, a frontal downward pressure upon the
14 thumb tab (e.g. a user places his/her thumb parallel or on top of the thumb tab and applies a
15 singular downward pressure) until the rim portion, adjacent to the thumb tab, contacts the inside
16 flat part of the cap; (d) the container is placed upside down (i.e. inverted) on the white paper at
17 room temperature; and (e) after 30 minutes, the white paper is inspected to determine if the white
18 paper is contaminated with the blue crystal dye liquid.

19 In another embodiment, the cap and container assembly, in a closed position, forms
20 an air tight seal. The term "air tight" means the moisture ingress of the container (after three days)
21 was less than about 750 micrograms of water, preferably, about 250 micrograms of water, more
22 preferably, about 150 micrograms of water determined by the following test method: (a) place one
23 gram plus or minus 0.25 grams of molecular sieve in the container and record the weight; (b) the
24 container is closed by applying, in a singular motion, a frontal downward pressure upon the thumb
25 tab until the rim portion, adjacent to the thumb tab, contacts the inside flat part of the cap also
26 adjacent to the thumb tab; (c) place the closed container in an environmental chamber at conditions
27 of 80% relative humidity and 72 °F; (c) after one day, weigh the container containing the molecular
28 sieve; (d) after four days, weigh the container containing the molecular sieve; and (e) subtract the
29 first day sample from the fourth day sample to calculate the moisture ingress of the container in
30 units of micrograms of water.

31 Referring now to the drawings wherein like reference numerals designate identical
32 or corresponding parts throughout the several views, and more particularly to FIG. 1 wherein one
33 embodiment of the leakproof, resealable cap and container assembly 10 of the present invention
34 is illustrated. The assembly 10 consist essentially of a container 20 having a base 28, an internal
35 cavity 27, an outer surface 25, an upper 21 and lower 26 portion. The container 20 has a rim 22
36 at the upper portion 21. The assembly 10 also has a cap 30 which has a circular base 31 and a
37 cylindrical tubular skirt 33 extending perpendicularly and outwardly around the outer periphery of
38 the base 31. The cap 30 has opposing ends, at one end the cap 30 has a thumb tab 36 for
39 facilitating the opening and closing of the container, and a hinge 40 attached to the container 20.

1 The tab 36 and hinge 40 are positioned on opposing ends of the cap and extend perpendicularly and
2 outwardly from the skirt 33 of the cap 30.

3 The container may also have a flange 24 projecting radially outwardly from the
4 outer surface 25 of the container 20. The hinge 40 may also be attached to the container flange 24.
5 The hinge 40 also has a recess 42 that functions as a bending point during the opening and closing
6 of the container.

7 Suitable material for assembly 10 includes plastic (e.g. thermoplastics such as
8 polypropylene and polyethylene). In one embodiment, the cap 30 and container 20 may be
9 integrally molded of the plastic to form a hinge 40 therebetween. In one embodiment, the cap 30
10 and container 20 may be produced in a molding process and, in another embodiment, may be
11 molded in accordance with the mold similar to that disclosed in U.S. Patent Nos. 4,783,056 and
12 4,812,116, respectively. In a further embodiment, with such a process and mold, the assembly,
13 including the cap, container and hinge may be produced in accordance with the operation disclosed
14 in U.S. Patent Nos. 4,783,056 and 4,812,116 or, in another embodiment, may be produced in
15 accordance with U.S. Patent No. 5,723,085. The disclosure of these patents are incorporated by
16 reference herein.

17 In another embodiment, two step (i.e. thickened sections of the hinge) bridge the
18 recess 42 on opposing ends of the recess. In yet a further embodiment, the first element of the
19 hinge 40 is from about 0.03 inches to about 0.125 inches, preferably 0.06 inches, measured from
20 the center-line of the recess and the outside perimeter of the cap. In still yet another embodiment,
21 the second element of the hinge 40 is from about 0.1 inches to about 0.195 inches, preferably 0.125
22 inches, measured from the center-line of the recess to the outside perimeter of container.

23 In another embodiment, the thumb tab 36 (which is located in the frontal portion
24 of the cap) is from about 0.125 inches to about 0.325 inches, preferably 0.235 inches, measured
25 from the outside perimeter of the cap to the end of the tab. In still another embodiment, the
26 assembly 10 can be sealed and/or resealed by applying, in a singular motion, a frontal, downward
27 pressure upon the thumb tab to obtain a leakproof seal. As an example, a user places his/her thumb
28 parallel or on top of the thumb tab (i.e. the frontal portion of the container) and applies a singular
29 downward pressure until an audible snap is heard and then verified by visual inspection of uniform
30 cap position around the flange.

31 FIG. 2 refers to an overhead plan view of the assembly 10 to the present invention
32 in an opened position. The assembly 10 includes the container 20 and the cap 30 connected by the
33 hinge 40. The container 20 has the cavity 27, the rim 22, and the flange 24. The cap includes the
34 circular base 31, the inner wall 35 with the recess 32, and the thumb tab 36. The hinge 40 has two
35 elements, 41 and 43, respectively, formed by the recess. One element 41 is attached to the flange
36 24 of the container 20 and the second element 43 is attached to the cap 30.

37 FIG. 3 depicts a side elevation view of the present invention in a closed position.
38 The cap and container assembly 10 comprises the cap 30 and the container 20 connected by the
39 hinge 40. The container 20 has a flange 24 extending from the outer surface 25 and a base 28. The

1 cap 30 has a cylindrical skirt 33 and the thumb tab 36 extending perpendicularly outwardly from
2 the skirt 33. In a closed position, the skirt 33 of the cap 30 overlies the container 20 and lies upon
3 the flange 24 of the container 20.

4 FIG. 4 illustrates a cross-section view of the assembly 10 in a closed position. The
5 skirt 33 of the cap 30 overlies the container 20 and lies upon the flange 24 of the container 30 while
6 the rim 22 of the container 20 is situated within the recess 32 of the inner wall 35 of the skirt 33
7 of the cap 30. The container 20 can be sealed and/or resealed by applying, in a singular motion,
8 frontal, downward pressure upon the thumb tab 36 to obtain a leak proof seal and/or an air tight
9 seal.

10 FIG. 5 illustrates a cross-section view of one embodiment of the cap and container
11 assembly of the present invention made of polypropylene with measurements and angles detailed
12 in Figure 5. In this embodiment, the rim 22 has one engagement surface, which has about a 20
13 degree vertical inclination for locking engagement against the corresponding surface of the cap.
14 The rim 22 also has a rounded edge, which has about a 5 degree vertical inclination, for ease of
15 closing. The inner wall of the skirt 33 of the cap 30 has a recess 32 having a first angular plane
16 surface of about 5 degrees from the reference vertical, a second angular plane surface of about 21
17 degrees from a reference vertical, and a third angular plane surface of about 31 degrees from a
18 reference vertical. In another embodiment, the recess 32 has two angular plane surfaces -- (i.e. the
19 5 degree angular plane surface of Figure 5 is eliminated).

20 Numerous modifications and variations of the present invention are possible in light
21 of the above teachings. It is therefore to be understood that within the scope of the attendant claims
22 attached hereto, this invention may be practiced otherwise than are specifically disclosed herein.

1 **CLAIMS**

2 **What Is Claimed Is:**

- 3 1. A resealable container and cap assembly, consisting essentially of:
4 a container having an upper portion and an outer surface, said container having a
5 rim at said upper portion;
6 a cap having a circular base with an outer periphery and a cylindrical tubular skirt
7 extending perpendicularly and outwardly around said outer periphery of said base, said skirt having
8 an inner wall, said inner wall having at least one recess, said cap having opposing ends, said cap
9 including a thumb tab for facilitating the opening and closing of said container and a hinge attached
10 to said container, said thumb tab and said hinge being positioned on opposing ends of said cap and
11 extending perpendicularly and outwardly from said skirt of said cap; and
12 in a closed position, said skirt of said cap overlies said container and said rim of said
13 container being situated within said recess of said inner wall of said skirt of said cap that results
14 in a leakproof container.
- 15 2. The assembly of claim 1 wherein said container further comprises a flange
16 projecting radially outwardly from said outer surface of said container.
- 17 3. The assembly of claim 2 wherein said hinge is attached to said container
18 flange.
- 19 4. The assembly of claim 2 wherein said skirt of said cap is designed to overlie
20 and sit upon said container flange during said closed position.
- 21 5. The assembly of claim 1 wherein said cap and container assembly, in the
22 closed position, forms an airtight seal.
- 23 6. The assembly of claim 5 wherein the moisture ingress is less than about 150
24 micrograms of water after three days.
- 25 7. The assembly of claim 1 wherein said cap and container are molded of
26 plastic.
- 27 8. The assembly of claim 7 wherein said cap and container are integrally
28 molded of said plastic to form a hinge therebetween.
- 29 9. The assembly of claim 1 wherein said cap is press-fit to said rim of said
30 container during said closed position.
- 31 10. The assembly of claim 1 wherein said hinge has a recess, said recess forms
32 two elements, one element being attached to said skirt of said cap and said second element being
33 attached to said container; said recess functions as a bending point during the opening and closing
34 of the container.
- 35 11. The assembly of claim 10 wherein said first element of said hinge is from
36 about 0.03 inches to about 0.125 inches measured from a center line of the recess and an outside
37 perimeter of said cap.

- 1 12. The assembly of claim 10 wherein said second element of said hinge is from
2 about 0.1 inches to about 0.195 inches measured from a center line of the recess to an outside
3 perimeter of said container.
- 4 13. The assembly of claim 1 wherein said thumb tab is from about 0.125 inches
5 to about 0.325 inches measured from an outside perimeter of said cap to an end of said thumb tab.
- 6 14. The assembly of claim 1 wherein said container can be sealed and resealed
7 by applying, in a singular motion, a frontal, downward pressure upon said thumb tab to obtain a
8 leakproof seal.
- 9 15. The assembly of claim 14 wherein said sealing produces an air tight seal.
- 10 16. A method of manufacturing a resealable container and cap assembly,
11 consisting essentially of the steps of:
12 providing a container and cap connected by a hinge, said container having an upper
13 portion and an outer surface, said container having a rim at said upper portion; said cap having a
14 circular base with an outer periphery and a cylindrical tubular skirt extending perpendicularly and
15 outwardly around said outer periphery of said base, said skirt having an inner wall having at least
16 one recess, said cap having opposing ends, said cap including a thumb tab, said tab and said hinge
17 being positioned on opposing ends of said cap and extending perpendicularly and outwardly from
18 said skirt of said cap; and
19 closing said container by applying, in a singular motion, a frontal, downward
20 pressure upon said thumb tab to allow said skirt to overlie said container and said rim of said
21 container to be situated within said recess of said inner wall of said skirt of said cap that results in
22 a leakproof container.
- 23 17. The method of claim 6 wherein said container further comprises a flange
24 projecting radially outwardly from said outer surface of said container.
- 25 18. The method of claim 6 wherein said closing step forms an air tight seal.
- 26 19. The method of claim 6 wherein said cap and container are molded of plastic.
- 27 20. A resealable container and cap assembly, consisting essentially of:
28 a container having an upper portion and an outer surface, and said container having
29 a rim at said upper portion, said rim having one engagement surface;
30 a cap having a circular base with an outer periphery and a cylindrical tubular skirt
31 extending perpendicular and outwardly around said base, said skirt having an inner wall, said inner
32 wall having a recess having at least two angular plane surfaces, said cap including a thumb tab for
33 facilitating the opening and closing of said container and a hinge attached to said container and said
34 hinge has a recess that functions as a bending point during opening and closing of the container,
35 said thumb tab and said hinge being positioned on opposing ends of said cap and extending
36 perpendicularly and outwardly from said skirt of said cap; and
37 in a closed position, said skirt of said cap overlies said container and said rim of said
38 container within said recess of said inner wall of said skirt of said cap that results in a leakproof,
39 air tight container.

- 1 21. The assembly of claim 20, wherein said recess of said hinge forms two
2 elements, one element being attached to said skirt and said second element being attached to said
3 container, said first element of said hinge is from about 0.03 inches to about 0.125 inches,
4 measured from a center line of said recess and an outside perimeter of said cap; and
5 wherein said recess of said inner wall of said cap has angular plane surfaces of about
6 15 to about 35 degrees from a reference vertical.
- 7 22. The assembly of claim 20 wherein the assembly in a closed position is less
8 than about 150 micrograms of water after three days.
9

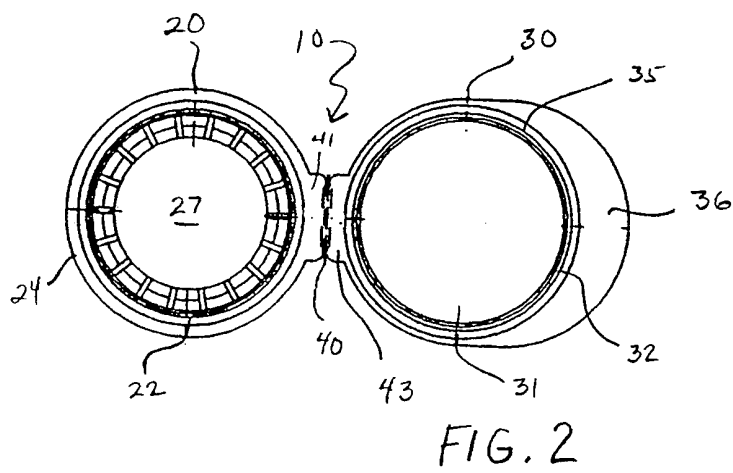
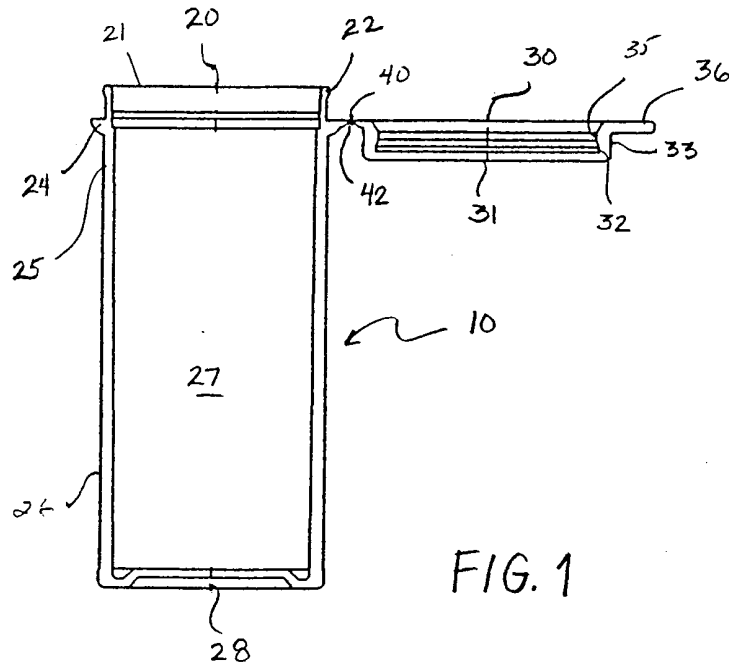

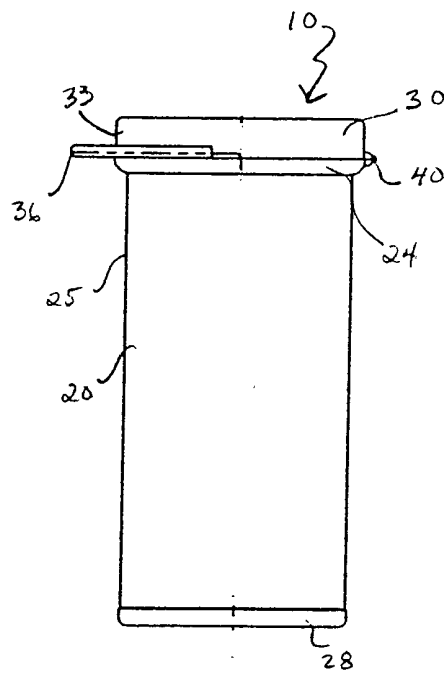

FIG. 3

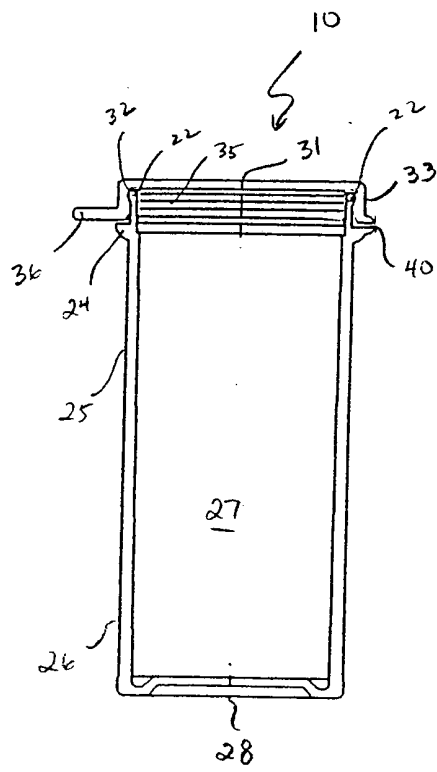

FIG. 4

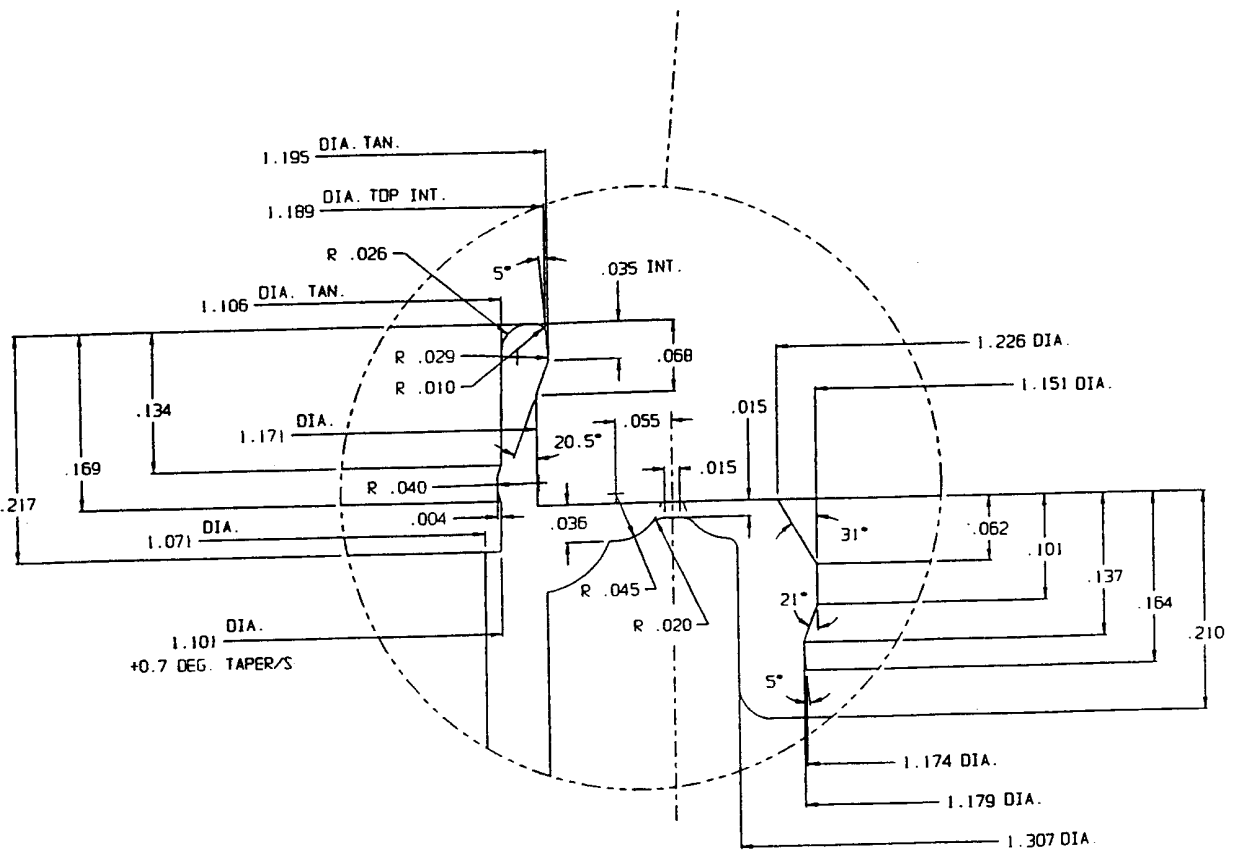

FIG. 5

INTERNATIONAL SEARCH REPORT

International application No.

PCT/US00/40796

A. CLASSIFICATION OF SUBJECT MATTER

IPC(7) : B65D 41/16
 US CL : 215/235

According to International Patent Classification (IPC) or to both national classification and IPC

B. FIELDS SEARCHED

Minimum documentation searched (classification system followed by classification symbols)
 U.S. : 215/235, 43, 45, 210, 321; 220/210, 836, 837, 839

Documentation searched other than minimum documentation to the extent that such documents are included in the fields searched

Electronic data base consulted during the international search (name of data base and, where practicable, search terms used)

C. DOCUMENTS CONSIDERED TO BE RELEVANT

Category *	Citation of document, with indication, where appropriate, of the relevant passages	Relevant to claim No.
X ---	US 5,474,177 A (ABRAMS et al.) 12 December 1995, column 5, line 2.	1-5, 9-18
Y		6-8, 19, 22
X ---	US 5,723,085 A (ABRAMS et al.) 03 March 1998, column 2, lines 33-35 and 45-46.	1-4, 7-10, 14, 16, 17, 19-21
Y		7, 8, 19
Y, P	US 6,050,400 A (TASKIS et al.) 18 April 2000, column 4, lines 61-64.	6, 22

Further documents are listed in the continuation of Box C.

See patent family annex.

* Special categories of cited documents:	"T"
"A" document defining the general state of the art which is not considered to be of particular relevance	later document published after the international filing date or priority date and not in conflict with the application but cited to understand the principle or theory underlying the invention
"E" earlier application or patent published on or after the international filing date	"X" document of particular relevance; the claimed invention cannot be considered novel or cannot be considered to involve an inventive step when the document is taken alone
"L" document which may throw doubts on priority claim(s) or which is cited to establish the publication date of another citation or other special reason (as specified)	"Y" document of particular relevance; the claimed invention cannot be considered to involve an inventive step when the document is combined with one or more other such documents, such combination being obvious to a person skilled in the art
"O" document referring to an oral disclosure, use, exhibition or other means	"&" document member of the same patent family
"P" document published prior to the international filing date but later than the priority date claimed	

Date of the actual completion of the international search
 06 December 2000 (06.12.2000)

Date of mailing of the international search report
05 JAN 2001

Name and mailing address of the ISA/US
 Commissioner of Patents and Trademarks
 Box PCT
 Washington, D.C. 20231
 Facsimile No. (703)305-3230

Authorized officer
Allan Shoap
Stephen Marcus
 Special Program Examiner
 Telephone No. (703)308-1148 Group 3710 & 3720