

(19) World Intellectual Property Organization
International Bureau



(43) International Publication Date
24 April 2008 (24.04.2008)

PCT

(10) International Publication Number
WO 2008/048477 A2

(51) International Patent Classification:

B60K 6/445 (2007.10) *B60K 5/08* (2006.01)
B60K 17/356 (2006.01) *B62D 11/14* (2006.01)
B60K 6/52 (2007.10)

(21) International Application Number:

PCT/US2007/021776

(22) International Filing Date: 12 October 2007 (12.10.2007)

(25) Filing Language: English

(26) Publication Language: English

(30) Priority Data:

60/851,537 13 October 2006 (13.10.2006) US

(71) Applicant (for all designated States except US): **THE OHIO STATE UNIVERSITY RESEARCH FOUNDATION** [US/US]; 1960 Kenny Road, Columbus, OH 4321-1063 (US).

(72) Inventors; and

(75) Inventors/Applicants (for US only): **CANTEMIR, Co-drin-Gruie** [RO/US]; 3941 Easton Way, Columbus, OH 43219 (US). **URSESCU, Gabriel, G.** [RO/RO]; Str. Codrescu, Nr. 7c, Bl.b3, Sc.a, Ap.4, Lasi, R-700480 Lasi (RO). **RIZZONI, Giorgio** [IT/US]; 1938 Concord Road, Upper Arlington, OH 43212 (US). **BECHTEL, James. UDVARE, Thomas** [—/US]. **LEATHERWOOD, Michael** [—/US].

(74) Agents: **MINNICH, Richard, J.** et al.; Fay Sharpe LLP, 1100 Superior Avenue, 7th Floor, Cleveland, OH 44114 (US).

(81) Designated States (unless otherwise indicated, for every kind of national protection available): AE, AG, AL, AM, AT, AU, AZ, BA, BB, BG, BH, BR, BW, BY, BZ, CA, CH, CN, CO, CR, CU, CZ, DE, DK, DM, DO, DZ, EC, EE, EG, ES, FI, GB, GD, GE, GH, GM, GT, HN, HR, HU, ID, IL, IN, IS, JP, KE, KG, KM, KN, KP, KR, KZ, LA, LC, LK, LR, LS, LT, LU, LY, MA, MD, ME, MG, MK, MN, MW, MX, MY, MZ, NA, NG, NI, NO, NZ, OM, PG, PH, PL, PT, RO, RS, RU, SC, SD, SE, SG, SK, SL, SM, SV, SY, TJ, TM, TN, TR, TT, TZ, UA, UG, US, UZ, VC, VN, ZA, ZM, ZW.

(84) Designated States (unless otherwise indicated, for every kind of regional protection available): ARIPO (BW, GH, GM, KE, LS, MW, MZ, NA, SD, SL, SZ, TZ, UG, ZM, ZW), Eurasian (AM, AZ, BY, KG, KZ, MD, RU, TJ, TM), European (AT, BE, BG, CH, CY, CZ, DE, DK, EE, ES, FI, FR, GB, GR, HU, IE, IS, IT, LT, LU, LV, MC, MT, NL, PL, PT, RO, SE, SI, SK, TR), OAPI (BF, BJ, CF, CG, CI, CM, GA, GN, GQ, GW, ML, MR, NE, SN, TD, TG).

Published:

— without international search report and to be republished upon receipt of that report

(54) Title: POWERTRAIN, VEHICLE AND METHODS

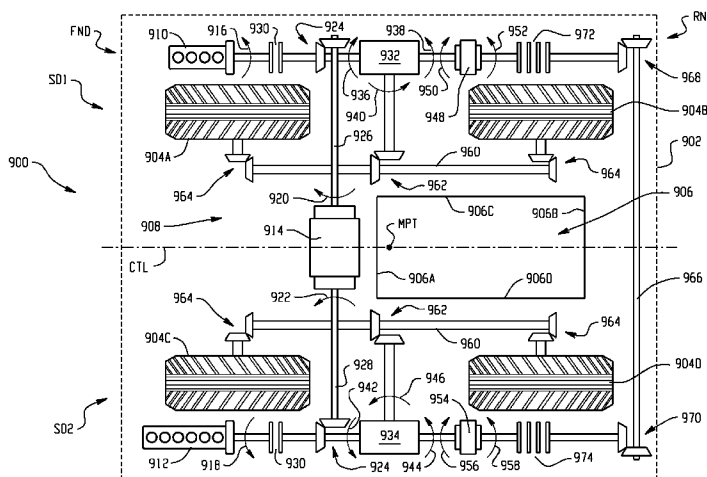

(57) Abstract: A powertrain is adapted to drive ground-engaging elements disposed along longitudinally-opposing sides of a vehicle. The powertrain includes at least one engine, a first electric machine, a second electric machine, a third electric machine, a first differential mechanism and a second differential mechanism. The engine and first electric machine are operatively connected to the first and second differential mechanisms. The second electric machine is operatively connected to the first differential mechanism and the third electric machine is operatively connected to the second differential mechanism. The first and second differential mechanisms are each operatively connected to drivably engage one or more ground-engaging elements disposed on a different one of the longitudinally-opposing sides of the associated vehicle. A vehicle including such a powertrain as well as methods of using the same are also included.

WO 2008/048477 A2

POWERTRAIN, VEHICLE AND METHODS

[0001] This application claims priority from U.S. Provisional Patent Application No. 60/851,537 filed on October 13, 2006, which is hereby incorporated herein by reference in its entirety.

BACKGROUND

[0002] The subject matter of the present disclosure broadly relates to the art of vehicle powertrains and, more particularly, to an electrically-variable powertrain for an all-wheel drive vehicle. The subject matter finds particular application and use in conjunction with high-performance, all-terrain personnel transport vehicles, and will be described herein with particular reference thereto. However, it is to be appreciated that the subject matter of the present disclosure is also amenable to use in other applications and environments, such as in passenger vehicles, light-duty trucks, sport-utility vehicles and other transport vehicles, for example. Thus, it will be appreciated that any specific reference herein to use in association with high-performance, all-terrain personnel transport vehicles is merely exemplary.

[0003] It will be appreciated that the present disclosure includes numerous rotating components (e.g., rotors, crankshafts, axles, gears) that can rotate at different speeds, rotate in different directions, transmit or carry different torsional loads, and/or transmit or carry different horsepower loads, as either inputs or outputs. For ease of reading and understanding, terms such as rotational connection, rotational output, rotational power source, and the like, have been used to broadly refer to any such rotational, torsional or power condition. Additionally, as used herein with reference to certain elements, features, components, structures and/or actions (e.g., "first electric machine," "second electric machine," "first rotational connection" and "second rotational connection"), numerical ordinals merely denote different singles of a plurality and do not imply any order or sequence unless specifically defined by the claim language.

[0004] Personnel transport vehicles of a variety of types and kinds are known and commonly used. In many of such known vehicles, the powertrain and other mechanical components are centrally located on the vehicle typically toward the bottom side thereof. It is well recognized that components of greater size and/or mass are often less significantly damaged by projectiles and the discharge from

explosive ordinance than are components of lesser size and/or mass. Though known arrangements provide some additional shielding against discharges from ordinance positioned underneath the vehicle, known arrangements do not utilize the mass of the powertrain components as supplemental shielding of the personnel compartment of the vehicle.

[0005] Additionally, known hybrid powertrains typically control the supply of motive power to the vehicle under an axle-by-axle type of operation. This is believed to be the case even when such a hybrid powertrain is used on an all-wheel drive vehicle. As such, as a vehicle is traveling on a succession of dry and icy surfaces, there is often only a small interval during which the axles are operating under different conditions from one another. As a vehicle is traveling along a partially snow-covered road, one side of the vehicle may be operating on dry pavement while the other side of the vehicle may be operating on snow and ice. Under such conditions, known hybrid powertrains are believed to provide less than optimal control of the vehicle.

[0006] Furthermore, known hybrid vehicles commonly operate in a manner that results in asymmetrical cornering of the vehicle. That is, these vehicles are believed to operate such that the front and rear wheels of the vehicle track along slightly different paths as the vehicle negotiates a turn or corner. In some circumstances, such operation may be undesirable because it could be possible for one wheel on one side of the vehicle to avoid hitting an object laying on the ground while the second wheel on that side of the vehicle might contact the object, such as during a cornering maneuver, for example.

[0007] Accordingly, it is believed desirable to develop an electrically-variable powertrain for an all-wheel drive vehicle as well as methods of operation that may overcome one or more of the foregoing and other disadvantages.

BRIEF DESCRIPTION

[0008] A vehicle in accordance with the present novel concept is provided that includes a vehicle structural assembly having a longitudinally-extending centerline with first and second vehicle structure portions extending along opposing sides of the centerline. A first plurality of ground-engaging elements is operatively disposed along the first vehicle structure portion on one of the opposing sides of the centerline. A second plurality of ground-engaging elements is operatively disposed

along the second vehicle structure portion on the other of the opposing sides of the centerline. A vehicle powertrain drivably engages one or more ground-engaging elements of each of the first and second pluralities of ground-engaging elements. The vehicle powertrain includes at least one engine that includes an engine rotational connection. The vehicle powertrain also includes a first electric machine. The first electric machine includes a first EM rotational connection that is operatively connected to the engine rotational connection. The vehicle powertrain also includes second and third electric machines. The second electric machine includes a second EM rotational connection and the third electric machine includes a third EM rotational connection. The vehicle powertrain further includes first and second differentials. The first differential includes first, second and third DF rotational connections. The first DF rotational connection is operatively connected to the engine rotational connection and the first EM rotational connection. The second DF rotational connection is operatively connected to the second EM rotational connection. The third DF rotational connection is operatively connected to drivably engage the first plurality of ground-engaging elements on one opposing side of the centerline. The second differential includes fourth, fifth and sixth DF rotational connections. The fourth DF rotational connection is operatively connected to the engine rotational connection and the first EM rotational connection. The fifth DF rotational connection is operatively connected to the third EM rotational connection. The sixth DF rotational connection is operatively connected to drivably engage the second plurality of ground engaging elements on the other opposing side of the centerline.

[0009] A powertrain in accordance with the present novel concept that is adapted to drive associated ground-engaging elements disposed along longitudinally-opposing sides of an associated vehicle is provided that includes at least one engine having an engine rotational connection. A first electric machine includes a first EM rotational connection that is operatively connected to the engine rotational connection. A second electric machine includes a second EM rotational connection and a third electric machine includes a third EM rotational connection. A first differential mechanism includes first, second and third DF rotational connections. The first DF rotational connection is operatively connected to the engine rotational connection and the first EM rotational connection. The second DF rotational connection is operatively connected to the second EM rotational connection. The third DF rotational connection is operatively connected to drivably engage one or

more of the associated ground-engaging elements disposed on one longitudinally-opposing side of the associated vehicle. A second differential mechanism includes fourth, fifth and sixth DF rotational connections. The fourth DF rotational connection is operatively connected to the engine rotational connection and the first EM rotational connection. The fifth DF rotational connection is operatively connected to the third EM rotational connection. The sixth DF rotational connection is operatively connected to drivably engage one or more associated ground-engaging elements disposed on the other longitudinally-opposing side of the associated vehicle.

[0010] A method of powering of vehicle in accordance with the present novel concept is provided that includes providing a vehicle structural assembly including a longitudinally-extending centerline and opposing vehicle structure sides. The method also includes providing first and second pluralities of ground-engaging elements with the first plurality of ground-engaging elements disposed along one opposing vehicle structure side and the second plurality of ground-engaging elements disposed along the other opposing vehicle structure side. The method also includes providing a vehicle powertrain including a first engine, a first electric machine, a second electric machine, a third electric machine, and first and second differentials. The method further includes transmitting rotational output from at least the first engine to the first and second differentials. The method also includes transmitting rotational output from at least one of the first electric machine and the second electric machine to the first differential and transmitting rotational output from at least one of the first electric machine and the third electric machine to be second differential. The method further includes transmitting rotational output from the first differential to the first plurality of ground-engaging elements to operatively drive one of the opposing vehicle structure sides and transmitting rotational output from the second differential to the second plurality of ground-engaging elements to operatively drive the other of the opposing vehicle structure sides.

[0011] A method of generating electrical power from a vehicle is provided that includes providing a vehicle structural assembly including a longitudinally-extending centerline and opposing vehicle structure sides. The method also includes providing first and second pluralities of ground-engaging elements with the first plurality of ground-engaging elements disposed along one of the opposing vehicle structure sides and the second plurality of ground-engaging elements disposed along the other of the opposing vehicle structure sides. The method further includes providing

a vehicle powertrain that includes a first engine, a first electric machine, a second electric machine, a third electric machine, and first and second differentials. The method also includes rotationally affixing the first and second pluralities of ground-engaging members such that rotational output from the first and second differentials can be respectively transmitted to the second and third electric machines. The method further includes transmitting rotational output from at least the first engine to at least one of the first electric machine, the first differential and the second differential. The method also includes generating electrical power at at least one of the first, second and third electric machines in response to the rotational output from the first engine.

BRIEF DESCRIPTION OF THE DRAWINGS

[0012] FIG. 1 is a schematic representation of one exemplary embodiment of a powertrain in accordance with the present novel concept shown operatively disposed on a vehicle.

[0013] FIG. 2 illustrates one exemplary method of powering a vehicle in accordance with the present novel concept.

[0014] FIG. 2A illustrates another exemplary method of powering a vehicle in accordance with the present novel concept.

[0015] FIG. 3 is a schematic representation of another exemplary embodiment of a powertrain in accordance with the present novel concept shown operatively disposed on a vehicle.

[0016] FIG. 4 illustrates still another exemplary method of powering a vehicle in accordance with the present novel concept.

[0017] FIG. 5 is a schematic representation of still another exemplary embodiment of a powertrain in accordance with the present novel concept shown operatively disposed on a vehicle.

[0018] FIG. 6 illustrates yet another exemplary method of powering a vehicle in accordance with the present novel concept.

[0019] FIG. 6A illustrates a further exemplary method of powering a vehicle in accordance with the present novel concept.

[0020] FIG. 6B illustrates still a further exemplary method of powering a vehicle in accordance with the present novel concept

[0021] FIG. 7 is a schematic representation of a further exemplary embodiment of a powertrain in accordance with the present novel concept shown operatively disposed on a vehicle.

[0022] FIG. 8 illustrates yet a further exemplary method of powering a vehicle in accordance with the present novel concept.

[0023] FIG. 8A illustrates a method of generating electrical power using a vehicle that includes a powertrain in accordance with the present novel concept.

DETAILED DESCRIPTION

[0024] Turning now to the drawings wherein the showings are for the purpose of illustrating exemplary embodiments of the present novel concept and which are not intended as a limitation of the same, FIGS. 1, 3, 5 and 7 each illustrate a vehicle that includes a vehicle structural assembly, such as a vehicle body, frame or chassis, for example. The vehicles include longitudinally-spaced first or forward ends **FND** and second or rearward ends **RND** and are also shown as including a longitudinally-extending centerline **CTL** that generally defines opposing first and second sides **SD1** and **SD2** of the vehicle.

[0025] The vehicle structural assemblies can be supported on an unsprung mass that can include a plurality of ground-engaging elements, such as wheels or linked tracks, for example, that are supported along each of opposing sides **SD1** and **SD2** of the vehicle. The unsprung mass can also include one or more structural members or other components, such as support arms (not shown), for example, operatively connecting the plurality of ground-engaging elements to the vehicle structural assembly. It will be appreciated that the pluralities of ground-engaging elements (e.g., wheels or linked tracks) as well as the structural members or other components operatively connecting the pluralities of ground-engaging elements to the sprung mass of the vehicle (e.g., a vehicle structural assembly) can be of any suitable type, kind and/or configuration.

[0026] Furthermore, the plurality of ground-engaging elements of the vehicles in each of FIGS. 1, 3, 5 and 7 is shown as including four ground-engaging elements with two of the ground-engaging elements disposed along each of the two opposing sides **SD1** and **SD2**. However, it will be appreciated that any suitable number of ground-engaging elements could alternately be used. In the exemplary embodiments shown, the four ground-engaging elements are spaced from one

another such that one ground-engaging element is disposed toward the forward and rearward corners of each of the opposing sides of the vehicle. Thus, the vehicle in FIG. 1 is also shown with a midpoint **MPT** disposed along centerline **CTL** approximately midway between the forward and rearward ground-engaging elements. It will be appreciated that the vehicles in FIGS. 3, 5 and 7 will have similar midpoints, though the same are not shown in the drawing figures.

[0027] With more specific reference to FIG. 1, a vehicle **100** includes a vehicle structural assembly **102** with a first plurality of ground-engaging elements, such as wheels **104A** and **104B**, for example, disposed along first side **SD1** and a second plurality of ground-engaging elements, such as wheels **104C** and **104D**, for example, disposed along second side **SD2**. Vehicle **100** also includes a powertrain **106** that is supported on vehicle structural assembly **102** and is operatively connected to drivably engage the plurality of ground-engaging elements (e.g., wheels **104A-D**).

[0028] Powertrain **106** includes an engine **108** that is supported on or along structural assembly **102**, and can be of any suitable type, kind and/or configuration. For example, engine **108** could be an internal combustion engine having one or more reciprocating pistons or, alternately, could be a rotary internal combustion engine. Additionally, engine **108** can be operable on any type or kind of fuel, such as gasoline, diesel, hydrogen, ethanol, biodiesel, for example, or any other suitable fuels or combination of fuels. Furthermore, an engine operating on a different thermodynamic cycle could alternately be used, such as a sterling cycle engine, for example. In one embodiment, engine **108** is a multi-cylinder internal combustion engine having an output power within a range of from about 50 hp to about 1000 hp. Additionally, normally aspirated engines or, alternately, engines utilizing forced air induction (e.g., turbo-charging, super-charging) can be used.

[0029] Powertrain **106** also includes a first, second and third electric machines, which are indicated in FIG. 1 by reference numbers **110**, **112** and **114**, respectively. The first, second and third electric machines are supported on or along structural assembly **102** in a suitable manner. Additionally, the first, second and third electric machines can be of any suitable type, kind or construction, and can include any suitable performance characteristics or specifications. Furthermore, the first, second and third electric machines can be of the same or different size, speed and/or power output relative to one another. In one exemplary embodiment, the second and third electric machines are substantially similar to one another and have a nominal power

output that is approximately half the nominal power output of the first electric machine. In another exemplary embodiment, the second and third electric machines can have a nominal power output that is approximately one-quarter of the nominal power output of the first electric machine.

[0030] Engine **108** includes an engine rotational connection **116** and can optionally include a clutch (not shown) for selectively disengaging the engine from rotational connection **116**. First electric machine **110** includes a first EM rotational connection **118**. In the exemplary embodiment shown, the engine and the first electric machine are supported on or along vehicle structural assembly **102** in approximately parallel relation such that engine rotational connection **116** and first EM rotational connection **118** are disposed adjacent one another. A first transmission **120** is operatively connected between engine rotational connection **116** and first EM rotational connection **118**. In the exemplary embodiment shown, first transmission **120** is a fixed ratio transmission that is operable to maintain a ratio of angular velocities between the engine and the first electric machine. It will be appreciated that the ratio of the first transmission can be selected based upon the desired output and other performance characteristics of a given application and/or use of powertrain **106**. Alternately, a variable ratio transmission could optionally be used. In either case, first transmission **120** includes a rotational connection **122** that transmits the resulting or combined rotational output from the engine and first electric machine.

[0031] Powertrain **106** also includes first and second differentials or differential mechanisms **124** and **126**. First differential **124** includes three rotational connections, which are respectively referred to herein as first, second and third rotational connections **128**, **130** and **132**. Similarly, second differential includes three rotational connections, which are respectively referred to as fourth, fifth and sixth rotational connections **134**, **136** and **138**. In the embodiment shown in FIG. 1, the resulting output from the engine and the first electric machine is delivered from rotational connection **122** to first and second differentials **124** and **126**. It will be appreciated that the transmission of the resulting rotational output to the first and second differentials can be achieved in any suitable manner. For example, a second transmission **140** that includes suitably sized transmission elements (e.g., gears) can be operatively connected between rotational connection **122** and the first and fourth rotational connections of the first and second differentials, respectively. In one

exemplary embodiment, it may be desirable to transfer the resulting rotational output from the engine and the first electric machine equally between the first and second differentials. In such case, second transmission **140** can include two substantially identical gears that are operatively interconnected between rotational connection **122** and rotational connections **128** and **134**. In practice first transmission **120** and second transmission **140** can be located or otherwise disposed in a common housing (not shown).

[0032] Second electric machine **112** includes a rotational connection **142** and third electric machine **114** also includes a rotational connection **144**. In the exemplary embodiment shown in FIG. 1, rotational connection **142** is operatively connected to rotational connection **132** of first differential **124** and rotational connection **144** is operatively connected to rotational connection **138** of second differential **126**. As such, rotational output can be transferred between the first differential and the second electric motor as well as between the second differential and third electric motor.

[0033] In the exemplary embodiment shown in FIG. 1, powertrain **106** also includes third and fourth differentials or differential mechanisms **146** and **148**, which are operatively connected for drivably engaging one or more of the plurality of ground-engaging elements of the vehicle. Third differential **146** includes three rotational connections, which are respectively indicated herein by reference numbers **150**, **152** and **154**. Similarly, fourth differential **148** includes three rotational connections, which are respectively indicated herein by reference numbers **156**, **158** and **160**. Rotational connection **130** of first differential **124** is operatively connected to rotational connection **150** of third differential **146**. Additionally, rotational connection **136** of second differential **126** is operatively connected to rotational connection **156** of fourth differential **148**.

[0034] Rotational output from third and fourth differentials **146** and **148** can be transferred to and/or from the ground-engaging elements (e.g., wheels **104A-D**) in any suitable manner. For example, as shown in FIG. 1, the ground-engaging elements can include final transmissions **162** that are drivably connected to rotational connections **152**, **154**, **158** and **160** for transferring rotational output therefrom. It will be appreciated, however, that any other suitable configuration and/or arrangement could ultimately be used.

[0035] One advantage of using a powertrain such as that shown in FIG. 1 is that the powertrain provides the capability to substantially independently control the motive power delivered to each of the two different sides of the vehicle. One exemplary method **200** of powering a vehicle using a powertrain in accordance with the present novel concept, such as powertrain **106**, for example, is shown in FIG. 2. Method **200** includes generating rotational output using engine **ENG**, as indicated by arrow **202**. Method **200** also includes transmitting a first portion of the rotational output to first electric machine **EM1**, as indicated by arrow **204**. The method also includes transmitting a second portion of the rotational output to differential mechanisms **DF1** and **DF2**, as is respectively indicated by arrows **206** and **208**. Method **200** further includes transmitting rotational output from first differential mechanism **DF1** to third differential mechanism **DF3**, as is indicated by arrow **210**. Method **200** also includes transmitting rotational output from second differential mechanism **DF2** to fourth differential mechanism **DF4**, as indicated by arrow **212**. Method **200** also includes transmitting rotational output from third and fourth differential mechanisms **DF3** and **DF4** to the respective ground-engaging elements, as indicated by arrows **214**.

[0036] Method **200** further includes generating electrical power using the rotational output transmitted from along arrow **204** to first electric machine **EM1** and transmitting the electrical power to suitable power electronics **PE**, as indicated by dashed arrow **216**. Method **200** also includes selectively transmitting electrical power from power electronics **PE** to second and/or third electric machines **EM2** and/or **EM3**, as indicated by dashed arrows **218** and **220**, respectively. Method **200** further includes transmitting rotational output from second and third electric machines **EM2** and **EM3** respectively to first and second differential mechanisms **DF1** and **DF2**, as indicated by arrows **222** and **224**. This additional rotational output is transmitted to third and fourth differential mechanisms **DF3** and **DF4** for respective transfer to sides **SD1** and **SD2** of the vehicle. Due at least in part to the characteristics of this additional rotational output, this method of operation is well suited for higher speed operation of the vehicle. Method **200** can further include selectively transferring electrical energy to and/or from storage device **STD**, as indicated by dashed arrow **226**.

[0037] As indicated by directional arrows **AR1** in FIG. 2, it will be appreciated that both sides **SD1** and **SD2** of the vehicle are being driven in the same direction during

operation according to method **200**. Another benefit of using a powertrain in accordance with the present novel concept, such as powertrain **106**, for example, is that under certain operating conditions it is possible to cause the vehicle to swing around a vertical axis thereof (e.g., an axis through midpoint **MPT**) to thereby change (e.g., reverse) the direction of the vehicle. More specifically, by reversing the rotational direction of one of the second and third electric machines, the rotational direction of the rotational output from the corresponding differential mechanisms is likewise reversed. This results in the associated ground-engaging elements rotating in the opposite direction.

[0038] One exemplary method of powering a vehicle in such a manner is illustrated in FIG. 2A as method **200'**. It will be appreciated that method **200'** is substantially similar to method **200** discussed above with regard to FIG. 2. Method **200'** differs from method **200** in that the rotational transmissions represented by arrows **212'**, **214'** and **224'** are in the opposing rotational direction. Thus, directional arrows **AR1** that were associated with third electric machine **EM3**, second differential mechanism **DF2** and ground-engaging elements **GE3** and **GE4** have been replaced by directional arrows **AR2**, indicating operation of these components in the opposing direction. As a result of ground-engaging elements **GE1** and **GE2** rotating in a first direction and ground-engaging elements **GE3** and **GE4** rotating in an opposing direction, the vehicle can pivot or otherwise swing about a vertical axis, such as an axis extending through midpoint **MPT** in FIG. 1, for example.

[0039] Turning now to FIG. 3, another exemplary embodiment of a vehicle **300** in accordance with the present novel concept is shown therein that includes a vehicle structural assembly **302** with a first plurality of ground-engaging elements, such as wheels **304A** and **304B**, for example, disposed along first side **SD1** and a second plurality of ground-engaging elements, such as wheels **304C** and **304D**, for example, disposed along second side **SD2**. Vehicle **300** also includes a powertrain **306** that is supported on vehicle structural assembly **302** and is operatively connected to drivably engage the first and second pluralities of ground-engaging elements (e.g., wheels **304A-D**).

[0040] Powertrain **306** is shown in FIG. 3 as including an engine **308**, a first electric machine **310**, a second electric machine **312**, a third electric machine **314** as well as first and second differentials **316** and **318**, respectively. It will be appreciated that powertrain **306** is substantially similar to powertrain **106** shown in and discussed

with regard to FIG. 1. As such, the features and elements relating to the rotational interconnections thereof are not repeated here.

[0041] Vehicle **300** differs from vehicle **100** in that vehicle **300** is equipped with an all-wheel steering system (not shown) that permits ground-engaging elements on the same side of the vehicle to be steered at the same angle. A central tire inflation system (not shown) or other similar arrangement can optionally be included to assist in maintaining a common rolling radius, if pneumatic wheels are used as ground-engaging elements. Accordingly, the speed of both of the wheels or other ground-engaging elements on a given side of the vehicle will be the approximately equal. Thus, third and fourth differentials **146** and **148**, which were utilized in FIG. 1 to permit ground-engaging elements on a given side of the vehicle to have different speeds, have been eliminated from powertrain **306**. As such, first and second differentials **316** and **318** are operatively connected to drivably engage the plurality of ground-engaging elements on respective sides of the vehicle.

[0042] First and second differentials **316** and **318** respectively include three rotational connections, as discussed above with regard to differentials **124** and **126**. For purposes of the present discussion, only one rotational connection of each of first and second differentials **316** and **318** is identified in FIG. 3, which rotational connections are identified by reference numbers **320** and **322**. It will be appreciated that first and second differentials **316** and **318** can drivably engage the plurality of ground-engaging elements in any suitable manner. For example, drive shafts **324** and **326** can be disposed along opposing sides of the vehicle with intermediate transmissions **328** and **330**, respectively, operatively engaging rotational connections **320** and **322** of the first and second differentials. The drive shafts can then be operatively connected to the ground-engaging elements and any suitable manner, such as by using final transmissions **332**, for example.

[0043] Another exemplary method **400** of powering a vehicle using a powertrain in accordance with the present novel concept, such as powertrain **306**, for example, is shown in FIG. 4. Method **400** includes generating rotational output using engine **ENG**, as indicated by arrow **402**. Method **400** also includes transmitting a first portion of the rotational output to first electric machine **EM1**, as indicated by arrow **404**. The method also includes transmitting a second portion of the rotational output to differential mechanisms **DF1** and **DF2**, as is respectively indicated by arrows **406** and **408**. Method **400** further includes transmitting rotational output from first

differential mechanism **DF1** to ground-engaging elements **GE1** and **GE2** on or along side **SD1**, as is indicated by arrows **410**. Method **400** also includes transmitting rotational output from second differential mechanism **DF2** to ground-engaging elements **GE3** and **GE4** on or along side **SD2**, as indicated by arrow **412**.

[0044] Method **400** further includes generating electrical power using the rotational output transmitted from along arrow **404** to first electric machine **EM1** and transmitting the electrical power to suitable power electronics **PE**, as indicated by dashed arrow **414**. Method **400** also includes selectively transmitting electrical power from power electronics **PE** to second and/or third electric machines **EM2** and/or **EM3**, as indicated by dashed arrows **416** and **418**, respectively. Method **400** further includes transmitting rotational output from second and third electric machines **EM2** and **EM3** respectively to first and second differential mechanisms **DF1** and **DF2**, as indicated by arrows **420** and **422**. This additional rotational output is transmitted from the differential mechanisms to the ground-engaging elements along respective sides **SD1** and **SD2** of the vehicle. Furthermore, method **400** can optionally include selectively transferring electrical energy to and/or from storage device **STD**, as indicated by dashed arrow **424**.

[0045] In use on a vehicle that includes an all-wheel steering function, such as vehicle **300**, for example, method **400** can operate to selectively vary the rotational output from one of the second and third electric machines. This, in turn, varies the rotational output at the corresponding ground-engaging elements associated with that side of the vehicle, which permits the more effective use of the all-wheel steering function without the use of additional differentials mechanisms, such as third and fourth differentials **146** and **148** in FIG. 1, for example. As shown in FIG. 4, second electric machine **EM2** is operating at a greater speed than third electric machine **EM3**. Accordingly, directional arrows **AR1** associated with the second electric machine and side **SD1** are shown as being of greater length than directional arrows **AR3**, which are associated with third electric machine and side **SD2**.

[0046] Turning, now, to FIG. 5, a further exemplary embodiment of a vehicle **500** in accordance with the present novel concept is shown that includes a vehicle structural assembly **502** with a first plurality of ground-engaging elements, such as wheels **504A** and **504B**, for example, disposed along first side **SD1** and a second plurality of ground-engaging elements, such as wheels **504C** and **504D**, for example, disposed along second side **SD2**. Vehicle **500** also includes a powertrain **506** that is

supported on vehicle structural assembly **502** and is operatively connected to drivably engage the first and second pluralities of ground-engaging elements (e.g., wheels **504A-D**).

[0047] Powertrain **506** is shown in FIG. 5 as including an engine **508**, a first electric machine **510**, a second electric machine **512**, a third electric machine **514**, a first differential **516** and a second differential **518** as well as driveshafts **520** and **522**, intermediate transmissions **524** and **526**, and final transmissions **528**. As such, it will be appreciated that powertrain **506** is substantially similar to powertrain **306** shown in and discussed with regard to FIG. 3. Accordingly, the features and elements related to the operation and rotational interconnections thereof are not repeated here.

[0048] Powertrain **506** differs from powertrains **106** and **306** discussed above in that second and third electric machines **512** and **514** are capable of being mechanically interconnected to provide additional modes of operation and/or performance characteristics. It will be appreciated that the second and third electric machines can be selectively mechanically interconnected in any suitable manner.

[0049] In the exemplary embodiment shown in FIG. 5, second electric machine **512** includes a first rotational connection (not numbered) operatively connected to first differential **516** and a second rotational connection **530** generally opposite the first rotational connection. Similarly, third electric machine **514** includes a second rotational connection **532** disposed generally opposite the first rotational connection (not numbered), which first rotational connection is operatively connected to second differential **518**. Powertrain **506** also includes a differential shaft **534** that operatively interconnects second rotational connections **530** and **532**. Again, it will be appreciated that such interconnections can be of any suitable type, kind and/or configuration. For example, fixed ratio transmissions **536** and **538** can be included between the differential shaft and the second rotational connections of the second and third electric machines, respectively. Additionally, one or more clutches **540** (or other suitable devices) can be provided along differential shaft **534** or otherwise operatively connected between the second rotational connections of the second and third electric machines.

[0050] Clutch **540** provides the capability for the second rotational connections to be selectively rotatable relative to one another, which permits the powertrain to employ several different modes of operation. As one example, permitting relative

rotation of the second rotational connections of the second and third electric machines provides side-to-side mechanical differential action for accommodating different speeds of the two different sides of a vehicle, such as might be experienced when the vehicle is turning or cornering, for example. As another example, the second and third electric machines can be used to add rotational power to or subtract rotational power from one or both of the sides of the vehicle to provide increased directional control of the vehicle (i.e., increased steering capability). As a further example, utilizing the differential shaft and clutch to interconnect the second rotational connections of the second and third electric machines can result in a reaction torque being generated between the second and third electric machines that permits the engine to provide motive force to the vehicle without the use of any of the first, second or third electric machines. As still another example, the second and third electric machines can be coupled together by way of the differential shaft such that reaction torque from one differential can be transmitted to both of the second and third electric machines, which can permit additional electrical power to be generated thereby.

[0051] A further exemplary method **600** of powering a vehicle using a powertrain in accordance with the present novel concept, such as powertrain **506**, for example, is shown in FIG. 6. Method **600** includes generating rotational output using engine **ENG**, as indicated by arrow **602**. Method **600** also includes generating rotational output using first electric machine **EM1**, as indicated by arrow **604**. The method also includes transmitting the rotational output from engine **ENG** and first electric machine **EM1** to differential mechanisms **DF1** and **DF2**, as is respectively indicated by arrows **606** and **608**. Method **600** further includes delivering a first portion of the rotational output from first differential mechanism **DF1** to ground-engaging elements **GE1** and **GE2** on or along side **SD1**, as is indicated by arrows **610**. Method **600** also includes delivering a first portion of the rotational output from second differential mechanism **DF2** to ground-engaging elements **GE3** and **GE4** on or along side **SD2**, as indicated by arrow **612**.

[0052] Method **600** further includes delivering a second portion of the rotational output from first differential mechanism **DF1** to second electric machine **EM2** and delivering a second portion of the rotational output from second differential mechanism **DF2** to third electric machine **EM3**, as is respectively indicated by arrows **614** and **616**. Method **600** also includes generating electrical power using electric

machines **EM2** and **EM3** from the rotational output delivered thereto from along arrows **614** and **616**, respectively, and transmitting the electrical power to suitable power electronics **PE**, as indicated by dashed arrows **618** and **620**. Method **600** includes selectively transmitting electrical power from power electronics **PE** to first electric machine **EM1**, as indicated by dashed arrow **622**, which electrical power can be used to generate the rotational output indicated by arrow **604**. Furthermore, method **600** can optionally include selectively transferring electrical energy to and/or from storage device **STD**, as indicated by dashed arrow **624**.

[0053] Method **600** in FIG. 6 illustrates operation of a vehicle in a mode that is well suited for relatively low vehicle speeds. At such relatively low speeds, the torque output capacity of first electric motor **EM1** can be utilized, such as to accelerate the vehicle or for use over rough terrain, for example. During such operation, the second and third electric machines are operatively disconnected from one another, as indicated by arrows **626A** and **626B**, such that first and second electric machines **EM2** and **EM3** can rotate independently of one another, as indicated by directional arrows **AR4**. Accordingly, sides **SD1** and **SD2** of the vehicle can operate at different speeds, as indicated by directional arrows **AR1** and **AR3**.

[0054] Still a further exemplary method **700** of powering a vehicle using a powertrain in accordance with the present novel concept, such as powertrain **506**, for example, is shown in FIG. 6A. Method **700** includes generating rotational output using engine **ENG**, as indicated by arrow **702**. Method **700** differs from method **600**, however, in that method **700** permits motive power to be provided to the vehicle without the use of the first, second or third electric machines. Method **700** also include delivering substantially all of the rotational output from engine **ENG** to at least one of differential mechanisms **DF1** and **DF2**, as is respectively indicated by arrows **704** and **706**. Method **700** can further include delivering substantially all of the rotational output from first differential mechanism **DF1** to at least one of ground-engaging elements **GE1** and **GE2** on or along side **SD1**, as is indicated by arrows **708**. Method **700** can also optionally include delivering substantially all of the rotational output from second differential mechanism **DF2** to one or more of ground-engaging elements **GE3** and **GE4** on or along side **SD2**, as indicated by arrow **710**.

[0055] In FIG. 6A, method **700** indicates that second and third electric machines are operatively connected to one another, as indicated by arrow **712**. As such, rotational output (i.e., reaction torque) from first and second differentials **DF1** and

DF2 is respectively reacted to the second and third electric machines, as indicated by arrows **714** and **716**. However, because second and third electric machines **EM2** and **EM3** are operatively coupled together, no substantial rotational motion occurs between the second and third electric machines, as indicated by counter-rotating directional arrows **AR5**. Even without the operation of the first, second and third electric machines, however, the vehicle is capable of operation under engine power, as indicated by directional arrows **AR1**.

[0056] Another exemplary method **800** of powering a vehicle using a powertrain in accordance with the present novel concept, such as powertrain **506**, for example, is shown in FIG. 6B. Method **800** includes generating rotational output using engine **ENG**, as indicated by arrow **802** and generating rotational output using first electric machine **EM1**, as indicated by arrow **804**. The method also includes delivering substantially all of the rotational output from engine **ENG** and first electric machine **EM1** to differential mechanism **DF1**, as is indicated by arrow **806**. Method **800** further includes delivering a first portion of the rotational output from first differential mechanism **DF1** to ground-engaging elements **GE1** and **GE2** on or along side **SD1**, as is indicated by arrows **808**.

[0057] FIG. 6B represents a method of powering the ground-engaging elements on or along only one side of a vehicle, such as side **SD1**, for example. Such a mode of operation may be useful when the vehicle is primarily supported by only two wheels, such as when the vehicle is stranded on a rock or other ground feature, for example. As such, no rotational output is shown being delivered to second differential **DF2** or ground-engaging elements **GE3** and **GE4** corresponding thereto. As such, no rotational output is being delivered to third electric motor **EM3** from the second differential.

[0058] Method **800** also includes, however, delivering a portion of the rotational output from first differential mechanism **DF1** to second electric machine **EM2**, as indicated by arrow **810**. Method **800** also includes generating electrical energy using second electric machine **EM2** from at least a portion of the rotational output delivered thereto and transmitting the electrical energy to suitable power electronics **PE**, as indicated by dashed arrow **812**. Method **800** also includes selectively delivering electrical power to first electric machine **EM1** from power electronics **PE**, as indicated by arrow **814**.

[0059] Method **800** can also optionally include operatively interconnecting second and third electric machines **EM2** and **EM3**, such as by engaging clutch **540** of differential shaft **534**, for example. As a result of this interconnection, rotational motion can be transmitted from second electric machine **EM2** to third electric machine as indicated by directional arrows **AR6**. Accordingly, additional rotational output from first differential mechanism **DF1** can be reacted or otherwise transmitted to third electric machine **EM3** via second electric machine **EM2**, as indicated by arrow **816**. As such, method **800** can also optionally include generating electrical power using third electric machine **EM3** and transmitting the electrical power to power electronics **PE**, as indicated by arrow **818**. This additional electrical power can also be transmitted to first electric machine **EM1**, as indicated by arrow **814**, such as for increasing the rotational output being generated thereby, for example.

[0060] With reference to FIG. 7, a vehicle **900** includes a vehicle structural assembly **902** with a first plurality of ground-engaging elements, such as wheels **904A** and **904B**, for example, disposed along first side **SD1** and a second plurality of ground-engaging elements, such as wheels **904C** and **904D**, for example, disposed along second side **SD2**. Vehicle **900** also includes a powertrain **906** that is supported on vehicle structural assembly **902** and is operatively connected to drivably engage the first and second pluralities of ground-engaging elements (e.g., wheels **904A-D**). As shown in FIG. 7, vehicle structural assembly **902** includes a personnel or operator compartment **906** that is disposed within or at least partially enclosed by the vehicle structural assembly. It will be appreciated that personnel compartment **906** can be of any suitable shape, size and/or configuration as may be useful for receiving a vehicle operator and, optionally, one or more additional personnel and/or cargo. As shown in the present exemplary embodiment, compartment **906** can include opposing front and rear walls **906A** and **906B**, respectively, as well as opposing side walls **906C** and **906D**.

[0061] Powertrain **908** includes a first engine **910** that is supported on structural assembly **902** along side **SD1** thereof, and can be of any suitable type, kind, size and/or configuration. Powertrain **908** also includes a second engine **912** that is supported on structural assembly **902** along side **SD2** thereof, and can also be of any suitable type, kind, size and/or configuration. It will be appreciated that first and second engines **910** and **912** can be of the same or different sizes and/or configurations, without limitation. For example, first engine **910** is shown in FIG. 9 as

being a four cylinder engine whereas second engine **912** is shown as being a six cylinder engine.

[0062] Powertrain **908** also includes a first electric machine **914** that is operatively connected between first and second engines **910** and **912**. It will be appreciated that the first electric machine can be operatively connected between the first and second engines in any suitable manner. For example, in the embodiment shown in FIG. 7, first and second engines **910** and **912** respectively include rotational connections **916** and **918**. Additionally, first electric machine includes opposing rotational connections **920** and **922**. A transmission **924** is operatively connected along each of rotational connections **916** and **918**, and transmission shafts **926** and **928** are operatively connected between the transmissions and respective ones of rotational connections **920** and **922**. Furthermore, powertrain **908** can also include one or more clutches **930** disposed between the first and second engines and the first electric machine. Such clutches can be provided in any suitable manner to operatively disconnect the first engine from the first electric machine and the second engine from the first electric machine.

[0063] Powertrain **908** also includes a first differential **932** that is supported along side **SD1** of the vehicle and a second differential **934** that is supported along side **SD2** of the vehicle. First and second differentials **932** and **934** are each shown as being operatively connected to first engine **908**, second engine **910** and first electric machine **912** by way of transmissions **924**. As such, a portion of the total combined rotational output from the engines and first electric machine can be transmitted to one or both of the differentials.

[0064] First differential **932** includes three rotational connections, which are indicated in FIG. 7 by reference characters **936**, **938** and **940**. Similarly, second differential **934** includes three rotational connections, which are indicated in FIG. 7 by reference characters **942**, **944** and **946**. Rotational connections **936** and **942** are operatively connected to the engines and the first electric machine, as discussed above. Powertrain **908** also includes a second electric machine **948** that has two rotational connections, which are indicated by reference numbers **950** and **952**. Powertrain **908** also includes a third electric machine **954** that also has two rotational connections, which are indicated by reference numbers **956** and **958**. Rotational connections **938** and **952** respectively of first differential **932** and second electric machine **948** are operatively connected to one another. Additionally, rotational

connections **944** and **956** respectively of second differential **934** and third electric machine **954** are operatively connected to one another. Rotational connections **940** and **946** respectively of first and second differentials **932** and **934** are operatively connected to drivably engage one or more of the plurality of ground-engaging elements on each of the respective sides of the vehicle, as discussed above with regard to other embodiments. In one exemplary arrangement, transmission shafts **960**, intermediate transmissions **962** and final transmissions **964** can be used, such as has been discussed above in detail.

[0065] As discussed above with regard to powertrain **506** in FIG. 5, for example, second and third electric machines **948** and **954** are capable of being mechanically interconnected to provide different modes of operation and/or performance characteristics. It will be appreciated that the second and third electric machines can be selectively mechanically interconnected in any suitable manner. In the exemplary embodiment shown in FIG. 7, powertrain **908** includes a differential shaft **966** that operatively interconnects rotational connections **952** and **958** of second and third electric machines **948** and **954**, respectively. Again, it will be appreciated that such interconnections can be of any suitable type, kind and/or configuration. For example, transmissions **968** and **970** can be included between the differential shaft and the second rotational connections of the second and third electric machines, respectively. Additionally, clutches **972** and **974** (or other suitable devices) can be provided between the respective transmissions and rotational connections of the second and third electric machines.

[0066] It will be appreciated that powertrain **908** is similar to powertrain **506** discussed in detail above and can operate substantially similar thereto. One difference between powertrain **908** and powertrain **506** is that the components of powertrain **908** are disposed outwardly around personnel compartment **906**. Thus, the components of the powertrain are thereby capable of providing additional protection and/or shielding along two or more of walls **906A-D** of the personnel compartment. Another difference is that a second engine is provided in powertrain **908**. As such, the vehicle has improved capability to withstand damage to one side of the vehicle and still remain drivable, such as while using only about half of the powertrain components (e.g., those components disposed along the undamaged side of the vehicle). Still a further difference is that clutch **540** in powertrain **506** can experience differential shaft portions rotating at full speed in different directions,

whereas clutches **972** and **974** may experience about half of the speed due to the position thereof along the operative connection.

[0067] Still another exemplary method **1000** of powering a vehicle using a powertrain in accordance with the present novel concept, such as powertrain **908**, for example, is shown in FIG. 8. Method **1000** includes generating rotational output using at least one of first engine **ENG1**, as indicated by arrow **1002**, and second engine **ENG2**, as indicated by arrow **1004**. Method **1000** also includes transmitting a first portion of the rotational output to first electric machine **EM1**, as indicated by arrow **1006**. The method also includes transmitting a second portion of the rotational output to differential mechanisms **DF1** and **DF2**, as is respectively indicated by arrows **1008** and **1010**. Method **1000** further includes transmitting rotational output from first differential mechanism **DF1** and second differential mechanism **DF2** to the respective ground-engaging elements, as indicated by arrows **1012**.

[0068] Method **1000** further includes generating electrical power using the rotational output transmitted from along arrow **1006** to first electric machine **EM1** and transmitting the electrical power to suitable power electronics **PE**, as indicated by dashed arrow **1014**. Method **1000** also includes selectively transmitting electrical power from power electronics **PE** to second and/or third electric machines **EM2** and/or **EM3**, as indicated by dashed arrows **1016** and **1018**, respectively. Method **1000** further includes transmitting rotational output from second and third electric machines **EM2** and **EM3** respectively to first and second differential mechanisms **DF1** and **DF2**, as indicated by arrows **1020** and **1022**. This additional rotational output is transmitted to the ground-engaging elements disposed along sides **SD1** and **SD2** of the vehicle. Furthermore, method **1000** can optionally include selectively transferring electrical energy to and/or from storage device **STD**, as indicated by dashed arrow **1024**.

[0069] Method **1000** in FIG. 8 illustrates operation of a vehicle in a mode that is well suited for relatively high speed travel. At such relatively high speeds, the rotational output of the second and third electric motors is utilized, such as to maintain higher angular velocities of the powertrain components, for example. During such operation, the second and third electric machines are operatively disconnected from one another, as indicated by arrows **1026A** and **1026B**, such that first and second electric machines **EM2** and **EM3** can rotate independently of one another, as indicated by directional arrows **AR4**. This provides a mechanical

differential action such that sides **SD1** and **SD2** of the vehicle can operate at different speeds, as indicated by directional arrows **AR1** and **AR3**.

[0070] With reference to FIG. 8A, one exemplary method **1100** of generating electrical power using a vehicle that includes a powertrain in accordance with the present novel concept, such as powertrain **908**, for example, includes generating rotational output using at least one of first and second engines **ENG1** and **ENG2**, as is respectively indicated by arrows **1102** and **1104**. Method **1100** also includes transmitting a first portion of the rotational output to first electric machine **EM1**, as indicated by arrow **1106**. The method also includes transmitting a second portion of the rotational output to differential mechanisms **DF1** and **DF2**, as is respectively indicated by arrows **1108** and **1110**. Method **1100** differs from other previously discussed methods in that rather than delivering rotational output to the ground-engaging elements, method **1100** includes transmitting rotational output from first differential mechanism **DF1** and second differential mechanism **DF2** to second and third electric machines **EM2** and **EM3**, respectively, as indicated by arrows **1112** and **1114**. In this case, the ground-engaging elements are in a locked or otherwise non-rotatable condition, which causes substantially all of the rotational output from the differential mechanisms to be delivered to the second and third electric machines, as indicated by directional arrows **AR8**.

[0071] As indicated by arrows **1116A** and **1116B**, second and third electric machines **EM2** and **EM3** are operatively disconnected from one another. As such, the second and third electric machines can rotate independently from one another, as indicated by directional arrows **AR9**. Method **1100** further includes generating electrical power using the rotational output transmitted from along arrow **1106** to first electric machine **EM1** and transmitting the electrical power to suitable power electronics **PE**, as indicated by dashed arrow **1118**. Additionally, method **1100** includes generating electrical power using the rotational output transmitted from along arrows **1112** and **1114** to second and third electric machines **EM2** and **EM3**, and transmitting the electrical power to suitable power electronics **PE**, as indicated by dashed arrows **1120** and **1122**, respectively. Method **1100** further includes delivering electrical power from power electronics **PE** to an external power connection for supplying electrical power thereto, as indicated by arrow **1124**.

[0072] While the subject novel concept has been described with reference to the foregoing embodiments and considerable emphasis has been placed herein on the

structures and structural interrelationships between the component parts of the embodiments disclosed, it will be appreciated that other embodiments can be made and that many changes can be made in the embodiments illustrated and described without departing from the principles of the subject disclosure. Obviously, modifications and alterations will occur to others upon reading and understanding the preceding detailed description. Accordingly, it is to be distinctly understood that the foregoing descriptive matter is to be interpreted merely as illustrative of the present novel concepts and not as a limitation. As such, it is intended that the subject novel concepts be construed as including all such modifications and alterations insofar as they come within the scope of the appended claims and any equivalents thereof.

1. A vehicle comprising:

a vehicle structural assembly having a longitudinally-extending centerline with first and second vehicle structure portions extending along opposing sides of said centerline;

a first plurality of ground-engaging elements operatively disposed along said first vehicle structure portion on one of said opposing sides of said centerline;

a second plurality of ground-engaging elements operatively disposed along said second vehicle structure portion on the other of said opposing sides of said centerline; and,

a vehicle powertrain drivably engaging one or more ground-engaging elements of each of said first and second pluralities of ground-engaging elements, said vehicle powertrain including:

at least one engine including an engine rotational connection;

a first electric machine including a first EM rotational connection operatively connected to said engine rotational connection;

a second electric machine including a second EM rotational connection;

a third electric machine including a third EM rotational connection;

a first differential including first, second and third DF rotational connections, said first DF rotational connection being operatively connected to said engine rotational connection and said first EM rotational connection, said second DF rotational connection being operatively connected to said second EM rotational connection, and said third DF rotational connection being operatively connected to drivably engage said first plurality of ground-engaging elements on said one opposing side of said centerline; and,

a second differential having fourth, fifth and sixth DF rotational connections, said fourth DF rotational connection being operatively connected to said engine rotational connection and said first EM rotational connection, said fifth DF rotational connection being operatively connected to said third EM rotational connection, and said sixth DF rotational connection being operatively connected to drivably engage said second plurality of ground-engaging elements on said other opposing side of said centerline.

2. A vehicle according to claim 1, wherein said vehicle structural assembly includes an personnel compartment disposed along said centerline, and one or more of said engine, said first electric machine, said second electric machine, said third electric machine, said first differential and said second differential is disposed along said vehicle structural assembly outwardly of said operator compartment and thereby provides supplemental shielding of said personnel compartment.
3. A vehicle according to claim 1, wherein said rotational power output of said at least one engine is approximately equal to a combined total rotational power output of said first, second and third electric machines such that said at least one engine can drive said first, second and third electric machines and thereby generate electrical power.
4. A vehicle according to claim 1, wherein said ground-engaging elements are wheels, and said vehicle structural assembly includes one of a symmetric all-wheel steering system and a non-symmetric all-wheel steering system.
5. A vehicle according to claim 1, wherein said second and third electric machines respectively include fourth and fifth EM rotational connections, and said powertrain includes a differential shaft is operatively connected between said fourth and fifth EM connections.
6. A vehicle according to claim 5, wherein said at least one engine is a first engine and said rotational connection thereof is a first engine rotational connection, said powertrain includes a second engine that includes a second engine rotational connection, and said first electric machine includes a sixth EM rotational connection operatively connected to said second engine rotational connection of said second engine.
7. A vehicle according to claim 1 further comprising an electrical control system in communication with at least said first electric machine, said second electric machine and said third electric machine.

8. A vehicle according to claim 7 further comprising an electrical storage device in communication said electrical control system and adapted to transfer electrical power to and from at least one of said first electric machine, said second electric machine and said third electric machine.

9. A powertrain adapted to drive associated ground-engaging elements disposed along longitudinally-opposing sides of an associated vehicle, said powertrain comprising:

at least one engine including an engine rotational connection;

a first electric machine including a first EM rotational connection operatively connected to said engine rotational connection;

a second electric machine including a second EM rotational connection;

a third electric machine including a third EM rotational connection;

a first differential mechanism including first, second and third DF rotational connections, said first DF rotational connection being operatively connected to said engine rotational connection and said first EM rotational connection, said second DF rotational connection being operatively connected to said second EM rotational connection, and said third DF rotational connection operatively connected to drivably engage one or more associated ground-engaging elements disposed on one longitudinally-opposing side of the associated vehicle; and,

a second differential mechanism including fourth, fifth and sixth DF rotational connections, said fourth DF rotational connection being operatively connected to said engine rotational connection and said first EM rotational connection, said fifth DF rotational connection being operatively connected to said third EM rotational connection, and said sixth DF rotational connection operatively connected to drivably engage one or more associated ground-engaging elements disposed on the other longitudinally-opposing side of the associated vehicle.

10. A powertrain according to claim 9, wherein said second and third electric machines respectively include fourth and fifth EM rotational connections, and said powertrain includes a differential shaft is operatively interconnecting said fourth and fifth EM connections.

11. A powertrain according to claim 10 further comprising a clutch operatively disposed between said fourth and fifth EM rotational connections, said clutch being operative to selectively interconnect said fourth and fifth EM rotational connections.
12. A powertrain according to claim 11, wherein said differential shaft includes first and second shaft portions and said clutch is operatively interconnected between said first and second shaft portions.
13. A powertrain according to claim 11, wherein said clutch is a first clutch connected between said second EM rotational connection and said differential shaft, and said powertrain further comprises a second clutch connected between said third EM rotational connection and said differential shaft.
14. A powertrain according to claim 9, wherein said at least one engine is a first engine and said rotational connection thereof is a first engine rotational connection, said powertrain further comprising a second engine that includes a second engine rotational connection, and wherein said first electric machine includes a sixth EM rotational connection operatively connected to said second engine rotational connection of said second engine.
15. A powertrain according to claim 14 further comprising first and second clutches, said first clutch operatively disposed between said first engine rotational connection and said first EM rotational connection for selectively disconnecting said first engine and said first electric machine, and said second clutch operatively disposed between said second engine rotational connection and said sixth EM rotational connection for selectively disconnecting said second engine and said first electric machine.
16. A powertrain according to claim 9 further comprising third and fourth differential mechanisms, said third differential mechanism operatively connected between said third DF rotational connection of said first differential mechanism and said one or more associated ground-engaging elements disposed on said one longitudinally-opposing side of the associated vehicle, and said fourth differential mechanism operatively connected between said sixth DF rotational

connection of said second differential mechanism and said one or more associated ground-engaging elements disposed on said other longitudinally-opposing side of the associated vehicle.

17. A powertrain according to claim 9 further comprising a clutch operatively disposed between said engine rotational connection and said first EM rotational connection, said clutch being operative to selectively disconnect said engine and first EM rotational connections.

18. A method of powering a vehicle, said method comprising:

- a) providing a vehicle structural assembly including a longitudinally-extending centerline and opposing vehicle structure sides;
- b) providing first and second pluralities of ground-engaging elements with said first plurality of ground-engaging elements disposed along one of said opposing vehicle structure sides and said second plurality of ground-engaging elements disposed along the other of said opposing vehicle structure sides;
- c) providing a vehicle powertrain including a first engine, a first electric machine, a second electric machine, a third electric machine, a first differential and a second differential;
- d) transmitting rotational output from at least said first engine to said first and second differentials;
- e) transmitting rotational output from at least one of said first electric machine and said second electric machine to said first differential and transmitting rotational output from at least one of said first electric machine and said third electric machine to said second differential; and,
- f) transmitting rotational output from said first differential to said first plurality of ground-engaging elements to operatively drive said one of said opposing vehicle structure sides and transmitting rotational output from said second differential to said second plurality of ground-engaging elements to operatively drive said other of said opposing vehicle structure sides.

19. A method according to claim 18, wherein providing said vehicle structural assembly in a) includes providing a vehicle structural assembly that includes a personnel compartment, and providing said vehicle powertrain in c) includes positioning one or more of said first engine, said first electric machine, said

second electric machine, said third electric machine, said first differential and said second differential outwardly along said personnel compartment for providing supplemental protection to said personnel compartment.

20. A method according to claim 18, wherein transmitting rotational output in e) includes transmitting rotational output from said engine to said first electric machine and thereby generating electrical power at said first electric machine, transmitting at least a portion of said electrical power from said first electric machine to at least one of said second and third electric machines, and transmitting rotational output from said second electric machine to said first differential and transmitting rotational output from said third electric machine to said second differential.

21. A method according to claim 18, wherein transmitting rotational output in e) includes transmitting rotational output from said first differential to said second electric machine and from said second differential to said third electric machine and thereby generating electrical power at said second and third electric machines, transmitting at least a portion of said electrical power from at least one of said second and third electric machines to said first electric machine, and transmitting rotational output from said engine and said first electric machine to said first and second differentials.

22. A method according to claim 19 further comprising rotationally affixing said second and third electric machines relative to one another, disengaging said first electric machine from said first engine and transmitting rotational output from said engine to said first and second pluralities of ground-engaging elements through said first and second differentials to operatively drive the vehicle without electrically powering at least one of said first, second and third electric machines.

23. A method according to claim 19, wherein providing said vehicle powertrain in c) includes providing a second engine and transmitting rotational output in d) includes selectively transmitting rotational output from at least one of said first and second engines to said first and second differentials.

24. A method of generating electrical power from a vehicle, said method comprising:

- a) providing a vehicle structural assembly including a longitudinally-extending centerline and opposing vehicle structure sides;
- b) providing first and second pluralities of ground-engaging elements with said first plurality of ground-engaging elements disposed along one of said opposing vehicle structure sides and said second plurality of ground-engaging elements disposed along the other of said opposing vehicle structure sides;
- c) providing a vehicle powertrain including a first engine, a first electric machine, a second electric machine, a third electric machine, a first differential and a second differential;
- d) rotationally affixing said first and second pluralities of ground-engaging members such that rotational output from said first and second differentials can be respectively transmitted to said second and third electric machines;
- e) transmitting rotational output from at least said first engine to at least one of said first electric machine, said first differential and said second differential; and,
- f) generating electrical power at said at least one of said first, second and third electric machines in response to said rotational output from said first engine.

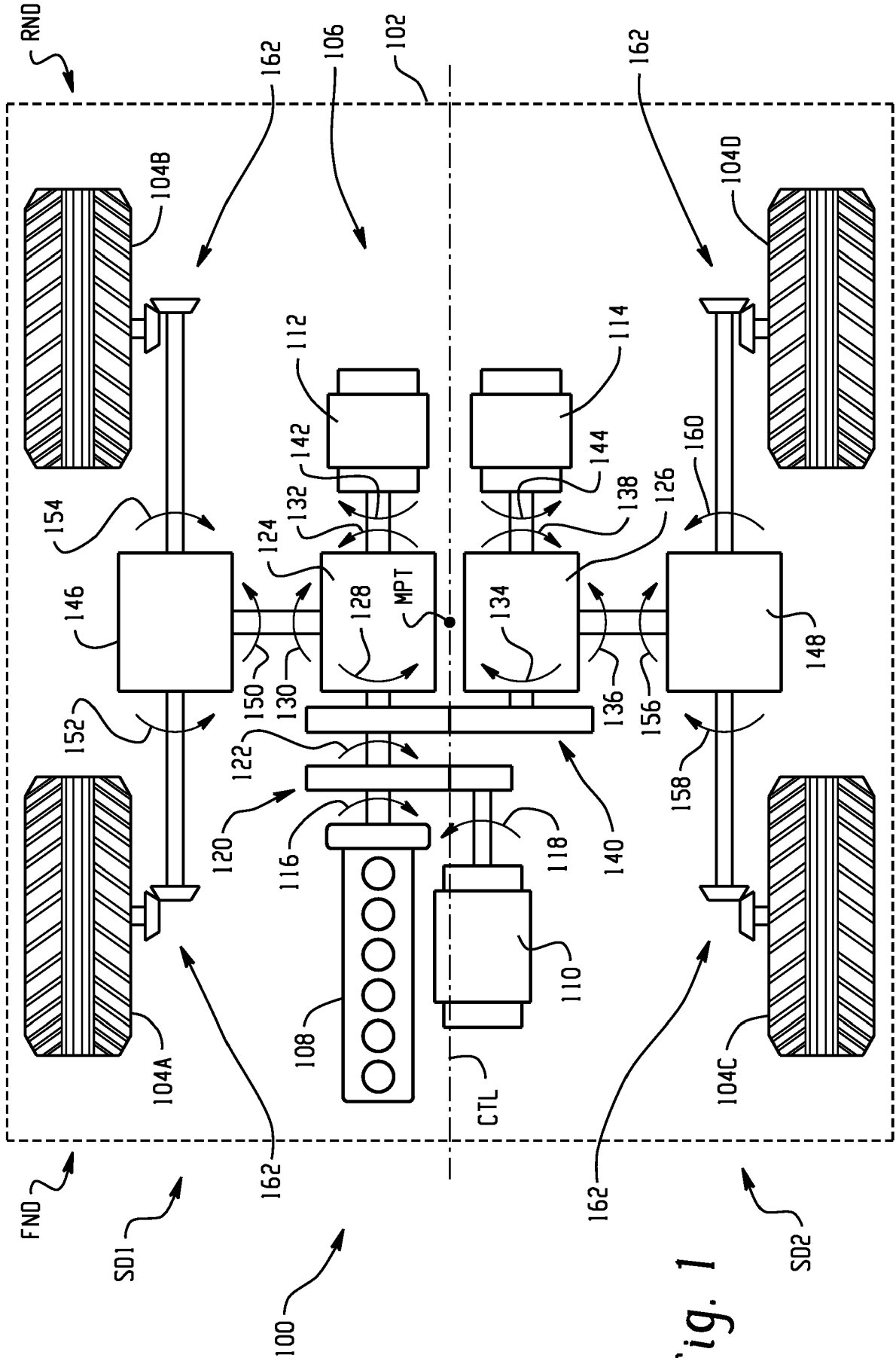

Fig. 1

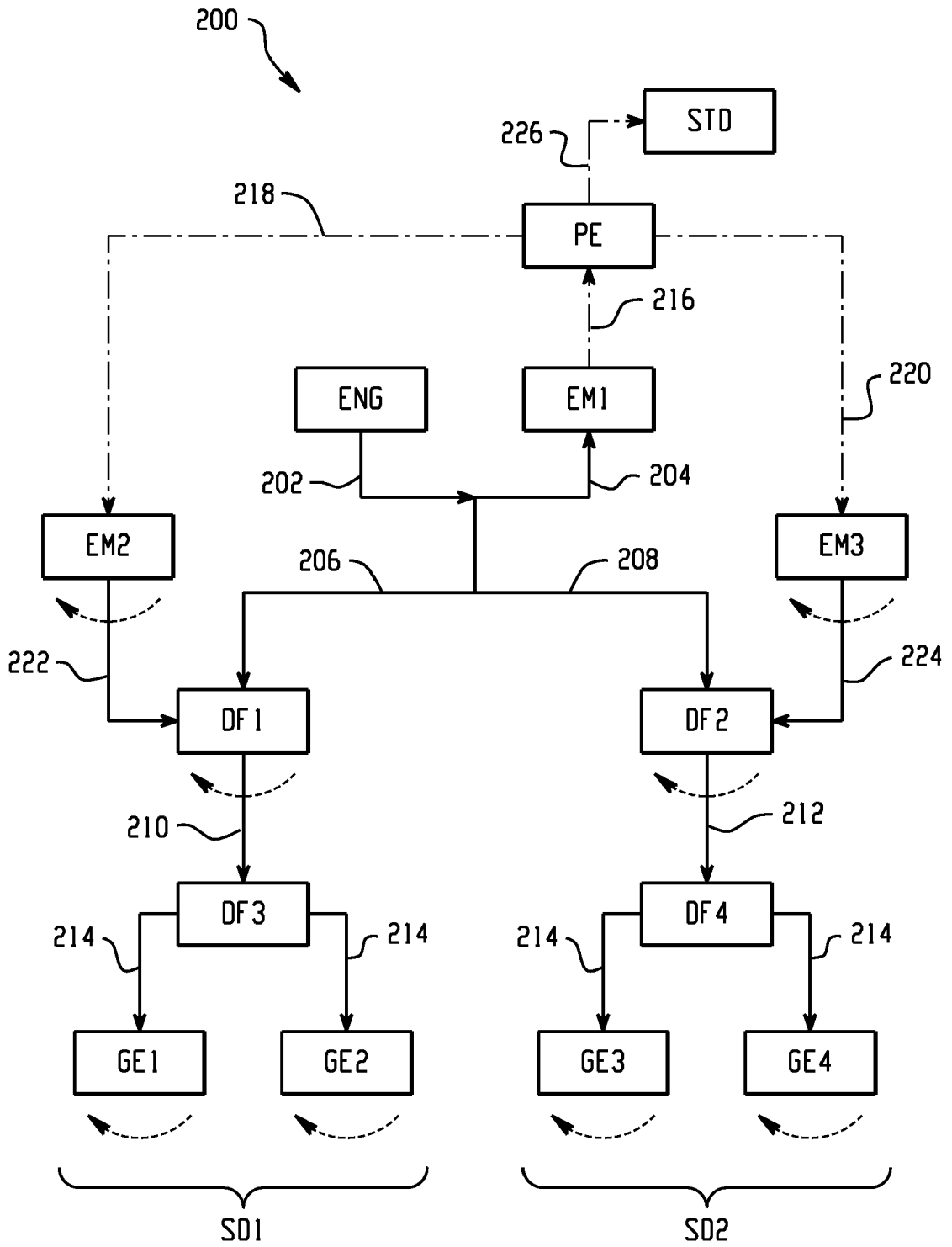

Fig. 2

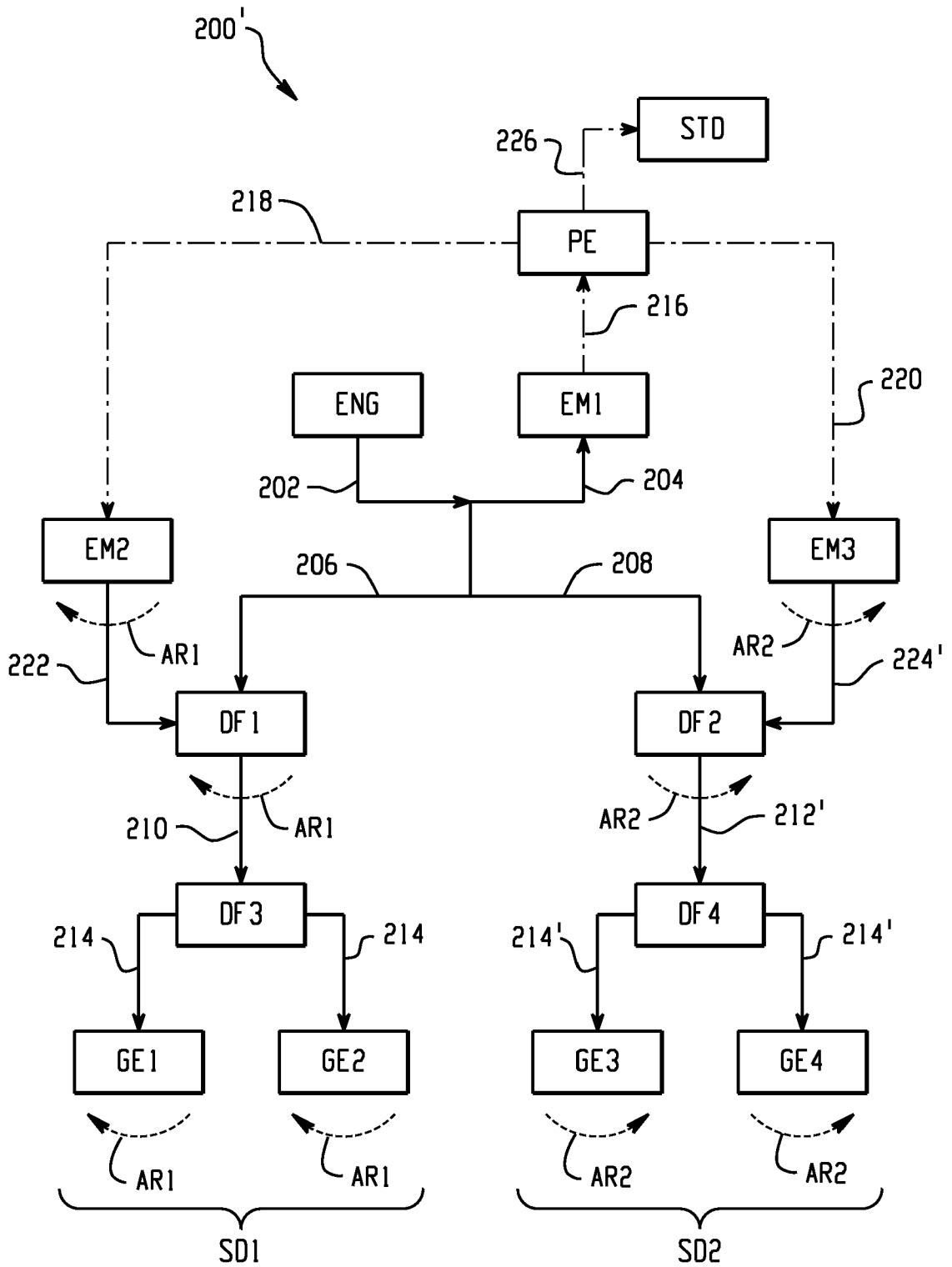

Fig. 2A

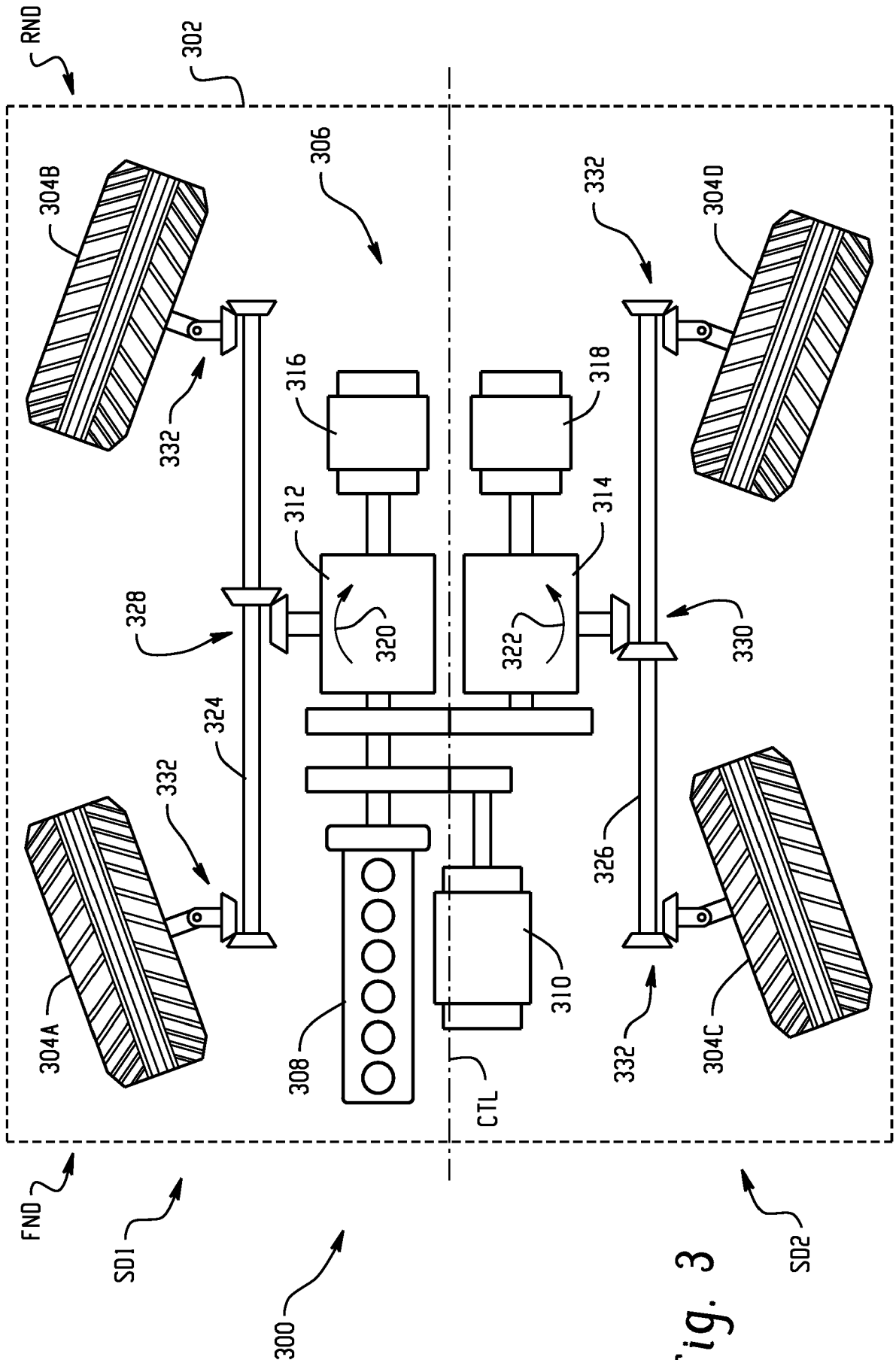

Fig. 3

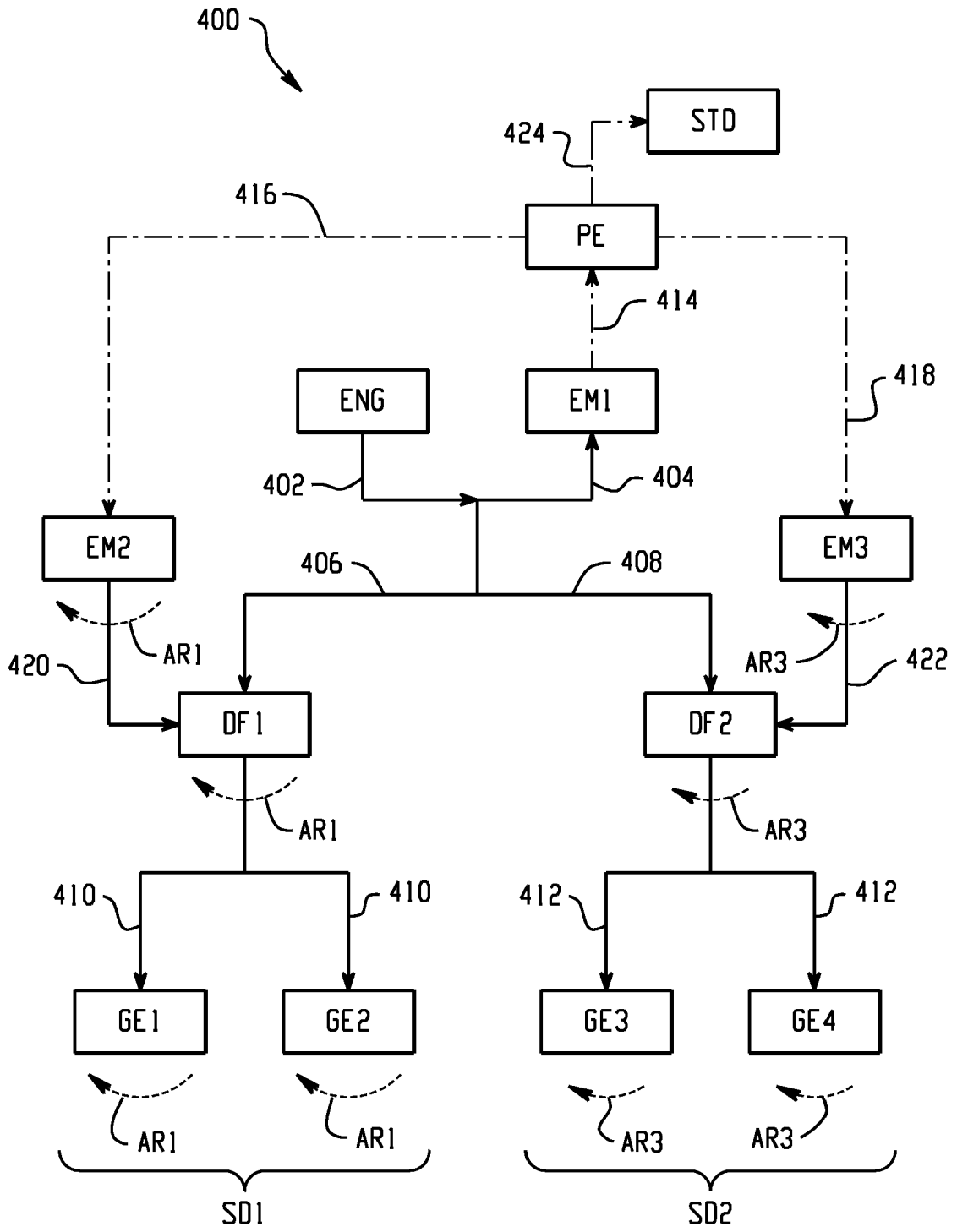

Fig. 4

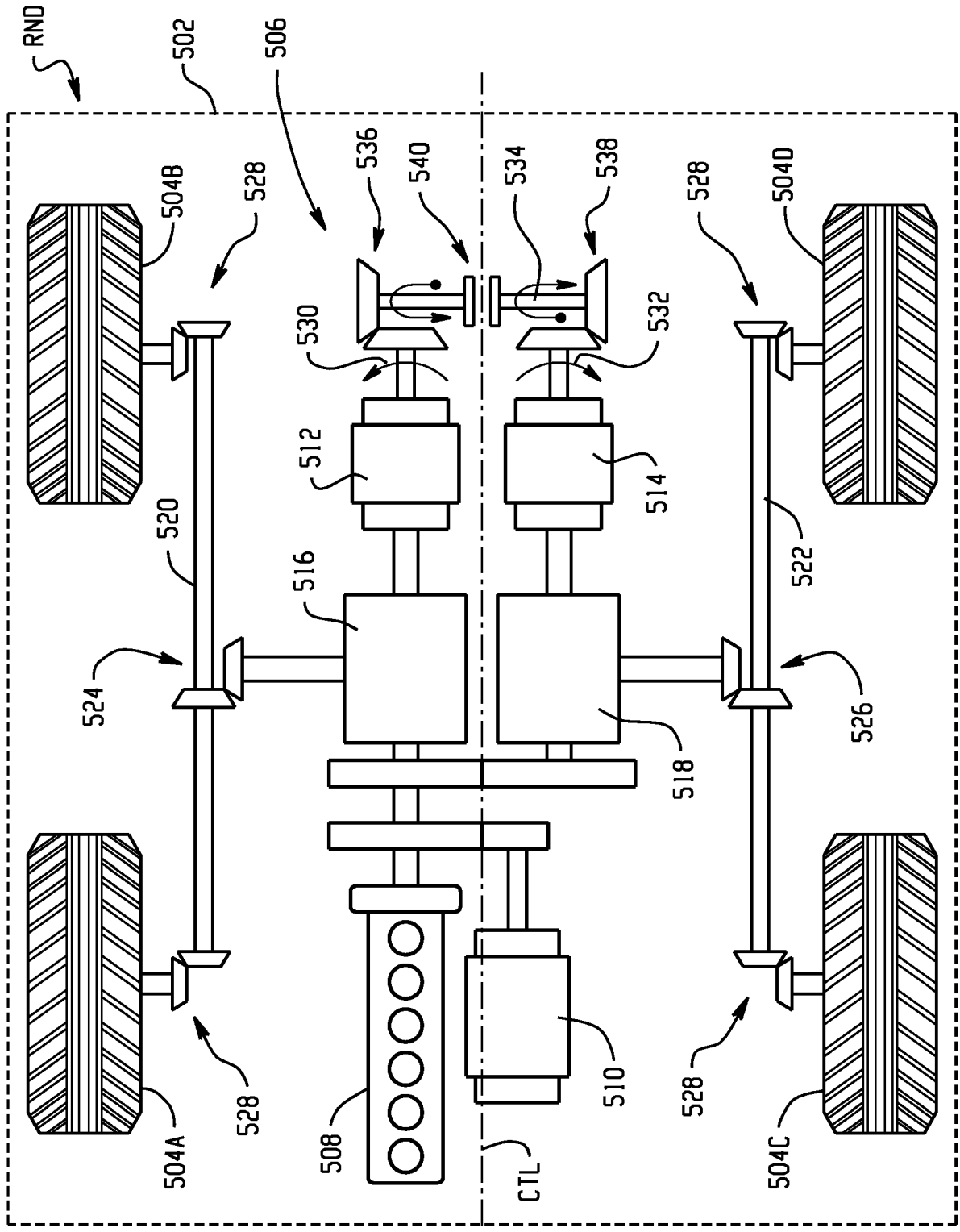

Fig. 5

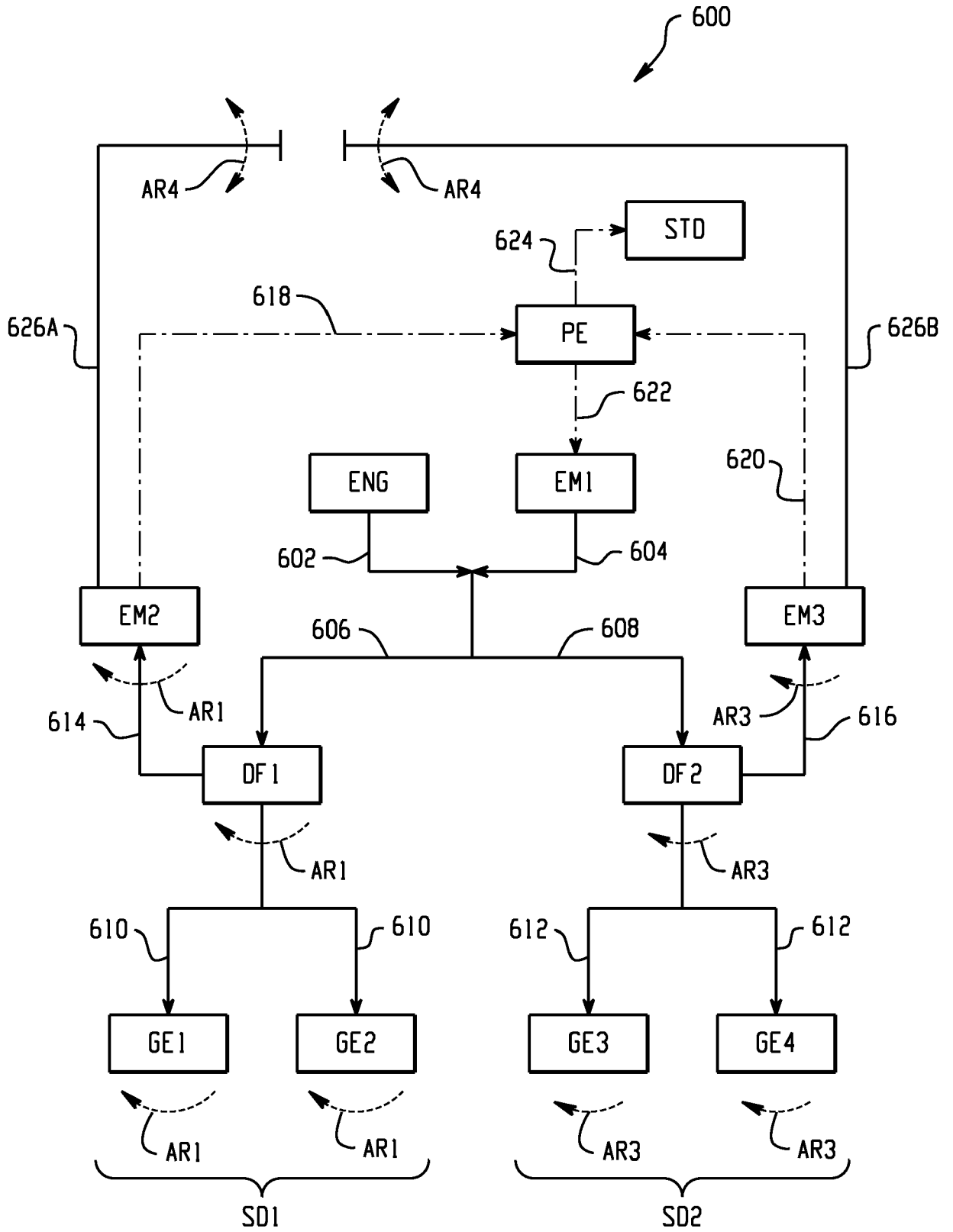

Fig. 6

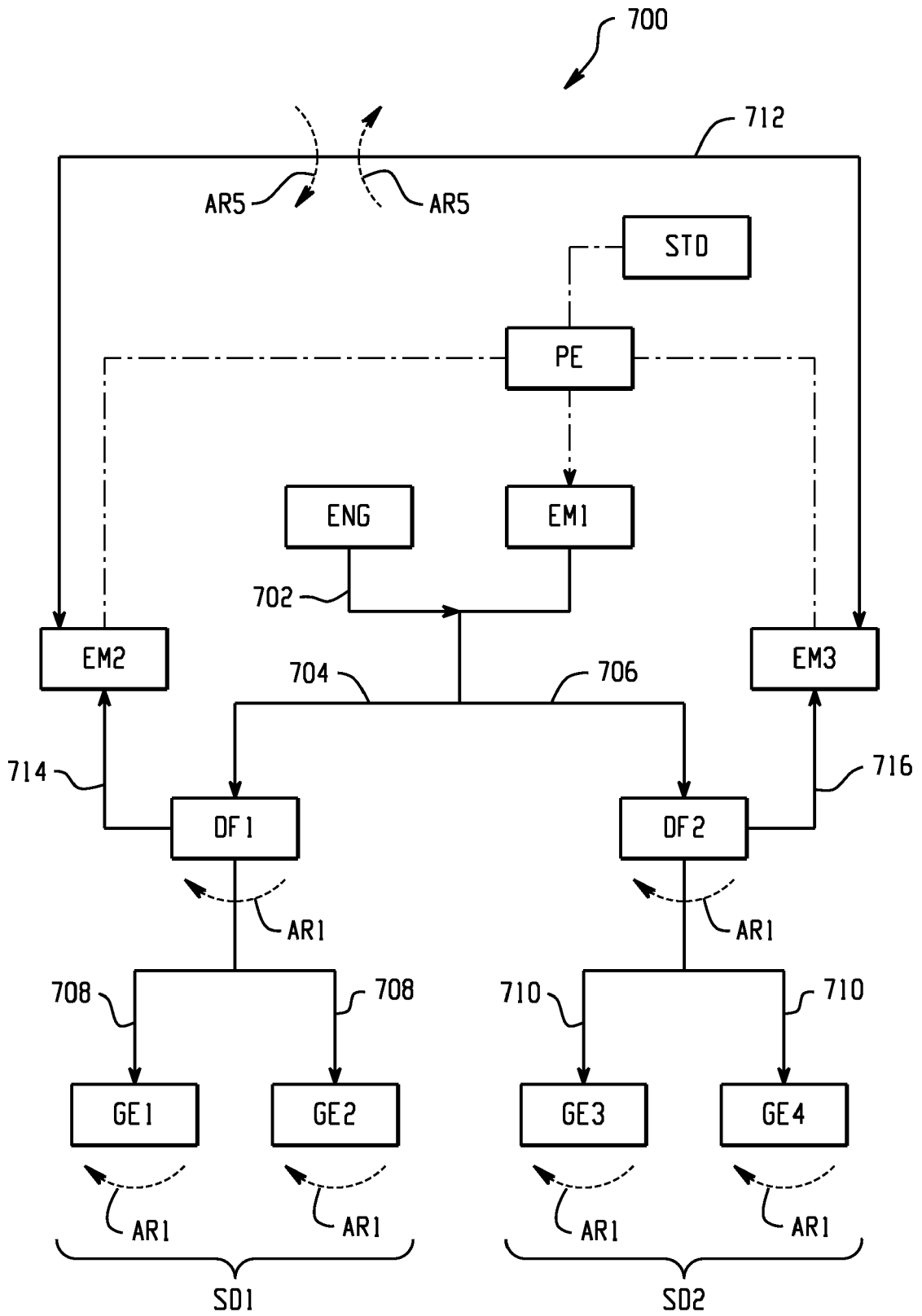

Fig. 6A

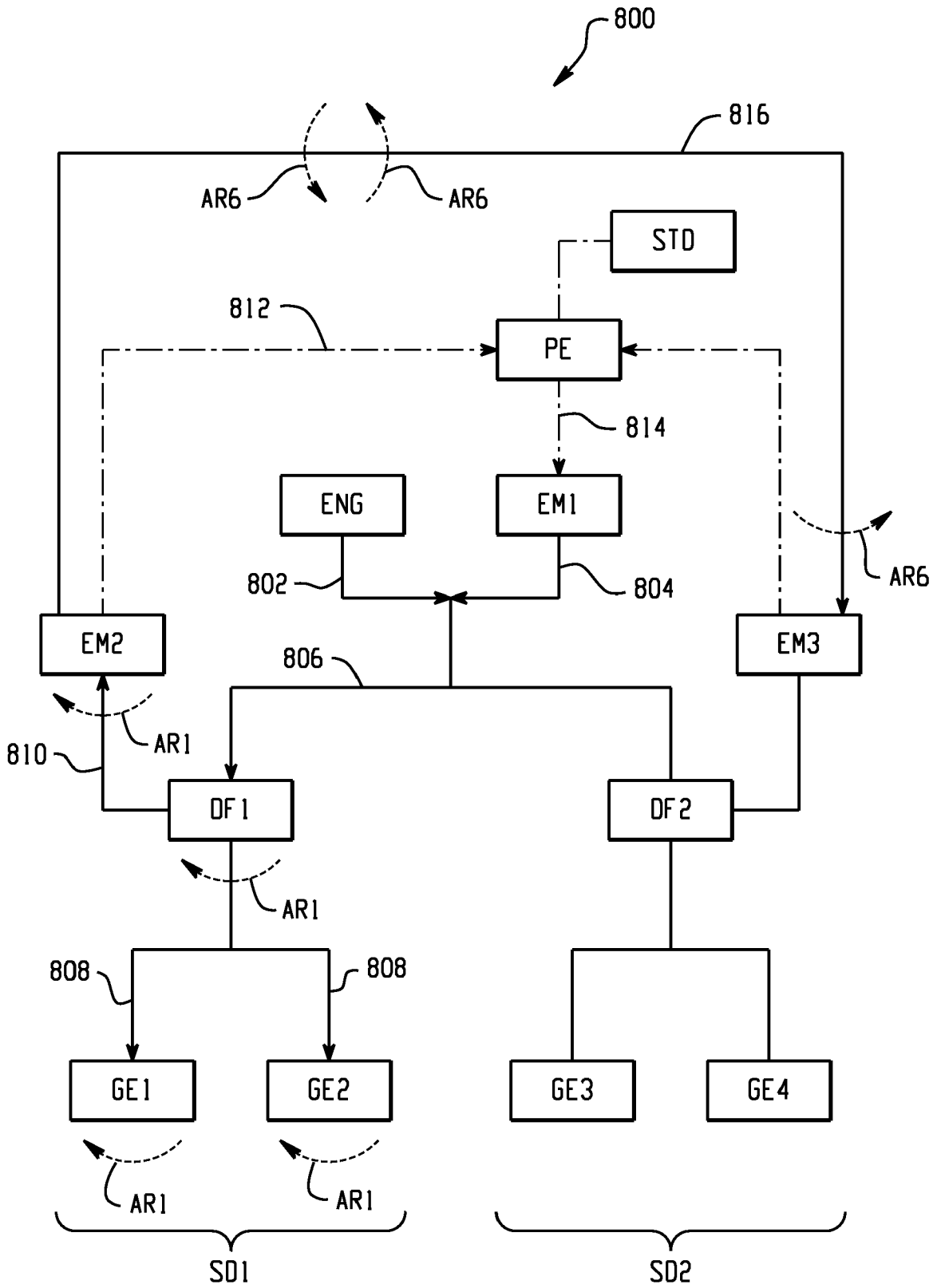
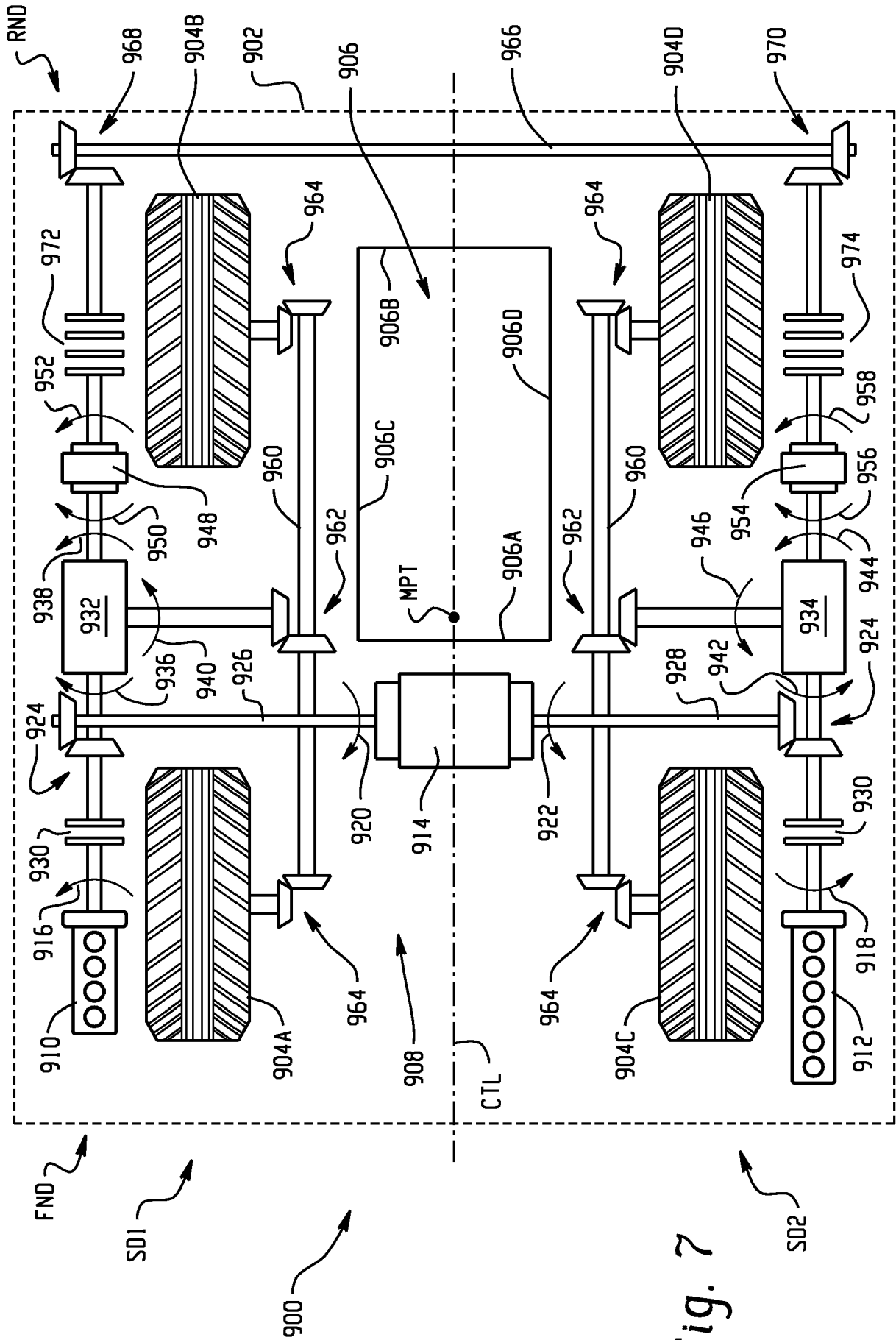

Fig. 6B



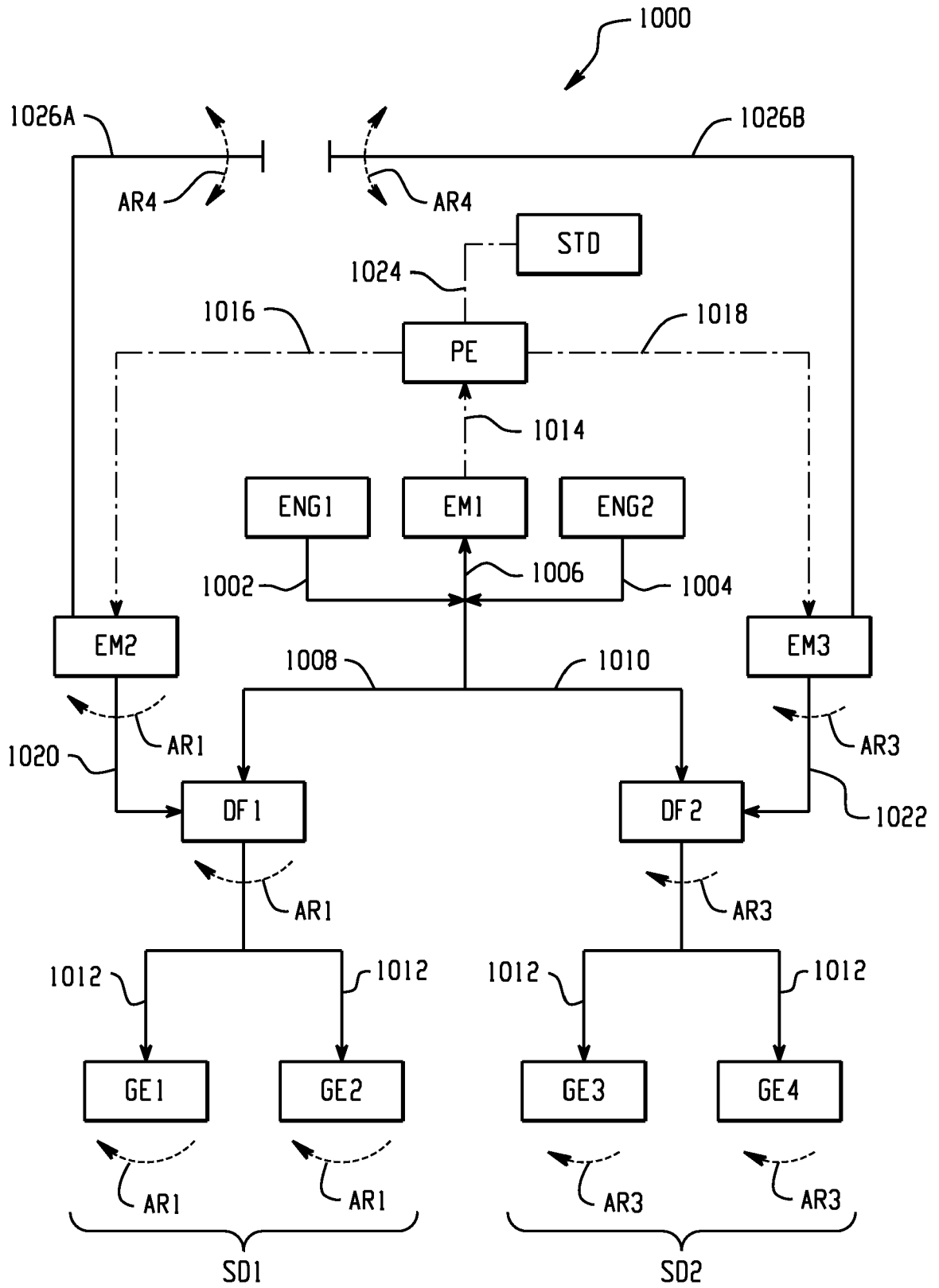

Fig. 8

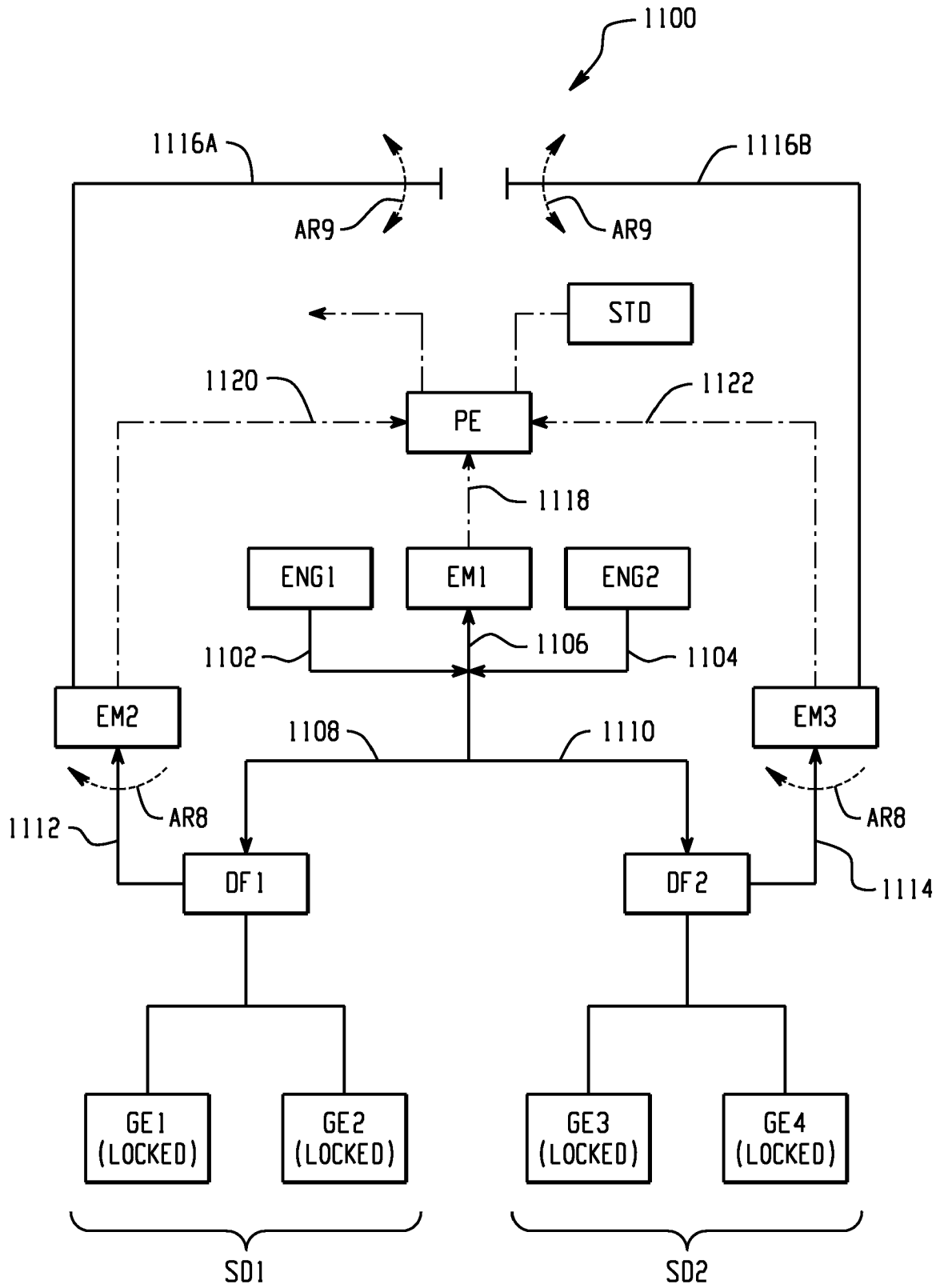

Fig. 8A