

L. W. Rosecrans,

Miter Box.

No. 108,296.

Patented Oct. 11, 1870.

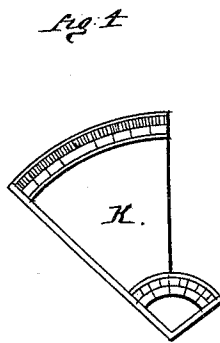
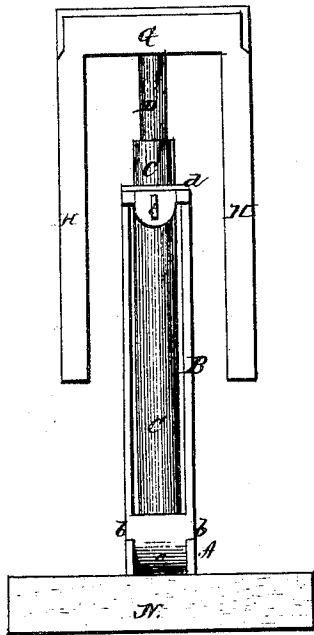
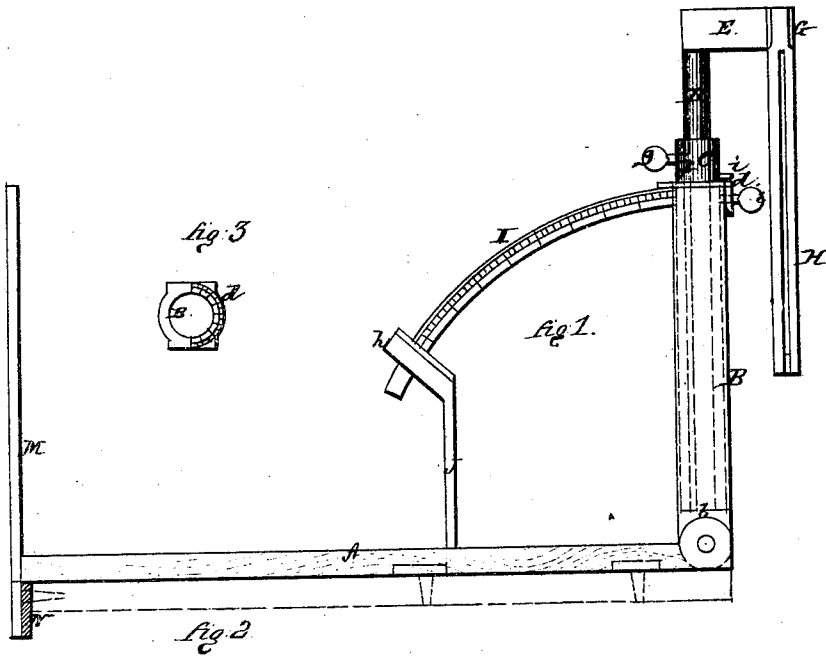

Inventor.
L. W. Rosecrans.
per
Alexander Murray

Attys

Witness
C. L. Cress
W. B. Mart

United States Patent Office.

LEANDER W. ROSECRANS, OF MARSHALLTOWN, IOWA.

Letters Patent No. 108,296, dated October 11, 1870.

IMPROVEMENT IN MITER-MACHINES.

The Schedule referred to in these Letters Patent and making part of the same

To all whom it may concern:

Be it known that I, LEANDER W. ROSECRANS, of Marshalltown, in the county of Marshall and in the State of Iowa, have invented certain new and useful Improvements in Guide for Hand-Saws; and do hereby declare that the following is a full, clear, and exact description thereof, reference being had to the accompanying drawing and to the letters of reference marked thereon, making a part of this specification.

The nature of my invention consists in the construction and arrangement of a "hand-saw guide," intended to guide the saw while cutting a board or plank at any one or two angles at the same time, the saw-guide being so arranged that it can be turned either to the right or left, raised up and down, and placed at any angle with the bed desired.

In order to enable others skilled in the art to which my invention appertains to make and use the same, I will now proceed to describe its construction and operation, referring to the annexed drawing, in which—

Figure 1 is a side view, and

Figure 2 is an end view of my machine.

Figure 3 is a plan view of a cylinder-frame used in the machine, and

Figure 4 is a side view of a degree-scale; also used with my machine.

A represents the bed-frame of my machine, at one end of which is hinged a cylinder-frame, B. This cylinder is, at its lower end, provided with a tenon, *a*, and a circular shoulder or bearing on either side. At the top it is provided with an indicator-plate, *d*, which is plainly shown in fig. 3.

A cylinder, C, passes through the frame B, its lower end being fastened to the tenon *a* by means of a pivot-screw, *f*, and its upper end extending a suitable distance above the indicator-plate *d*. This cylinder may be rotated on its pivot either to the right or left, and held at any point desired by means of a thumb-screw, E, passing through the cylinder-frame.

Through the cylinder C to the bottom thereof runs a rod, D, which is provided with a longitudinal groove, *f*, whose sides converge toward its center, and receives the frustum of the thumb-screw *g*, which passes through the cylinder, and keeps it from turning in the cylinder C, and allows it to be raised and lowered at will.

At the upper end of the rod D is an arm, E, provided at its outer end with a cross-head, G, having two bars, H H, extending downward parallel with the rod D, said bars being slotted longitudinally, as shown in fig. 1.

The cylinder C is, immediately above the indicator-plate *d*, provided with a needle-point or finger, *i*.

On the side of the cylinder-frame B, at its upper end, is attached a graduated or scale-brace, I, which passes through an inclined projection, *h*, on a post or standard, J, and is there secured by a thumb-screw.

At the other end of the frame A is another post or standard, M, and under the frame at this end is placed a board, N, crosswise, as shown in fig. 2.

The cylinder-frame B and posts J and M are so arranged that a board or plank placed alongside of the frame will touch the side of all three.

K is a degree-scale, the use of which will be presently explained.

The frame A is screwed to a plank, as shown by dotted lines in fig. 1, the board N bearing against its edge. Then set the bevel-tool to the required angle, apply the haft or handle against the base of the degree-scale K, with its blade across the face. Loosen the thumb-screw E, turn the cylinder C, with the needle-point *i*, at the corresponding point indicated by the bevel-tool on the degree-scale, then tighten the screw E again. Proceed in the same manner with the scale-brace I if a diagonal cut is wanted; that is, loosen the thumb-screw in the projection *h*, move the brace with the cylinder down to the left to the required point, and then tighten the screw.

Then take the timber; place its edge on the plank to which the frame A is secured, with the edges of the timber against the posts J M and the cylinder-frame B; then loosen the thumb-screw *g*, and raise the rod D until the lower ends of the guide-bars H H will be about one-half or three-fourths of an inch above the timber; then tighten the screw, insert the back of the saw in the slots in the guide-bars H H, and saw it down.

Having thus fully described my invention,

What I claim as new, and desire to secure by Letters Patent, is—

1. The cylinder-frame B, provided with the tenon *a* and circular shoulders or bearings *b b*, said frame being hinged to the bed or frame A, and braced by the scale-brace I, substantially as and for the purposes herein set forth.

2. The combination of the hinged cylinder-frame B with indicator-plate *d*, pivoted cylinder C, with needle-point *i*, longitudinally-grooved rod D, having the slotted guide-bars H H attached to its upper end, all substantially as and for the purposes herein set forth.

3. The frame or bed A, provided with posts J M

and board N, substantially as and for the purposes herein set forth.

4. The combination of the bed A, cylinder-frame B, cylinder C, rod D, guide-bars H H, scale-brace I, posts J M, and board N, all constructed and arranged to operate substantially in the manner and for the purposes herein set forth.

In testimony that I claim the foregoing, I have hereunto set my hand this 8th day of March, 1870.

LEANDER W. ROSECRANS.

Witnesses:

WM. H. SUMMERS,
T. W. HART.