

(19)



(11)

EP 3 530 873 B1

(12)

EUROPEAN PATENT SPECIFICATION

(45) Date of publication and mention of the grant of the patent:
11.10.2023 Bulletin 2023/41

(51) International Patent Classification (IPC):
E21B 33/128^(2006.01) E21B 34/06^(2006.01)
E21B 34/14^(2006.01)

(21) Application number: **18157788.3**

(52) Cooperative Patent Classification (CPC):
E21B 34/14; E21B 33/128; E21B 34/063;
E21B 2200/06

(22) Date of filing: **21.02.2018**

(54) **DEVICE ADAPTED TO BE RUN ON A TUBING STRING INTO A WELLBORE**

ZUR AUSFÜHRUNG AUF EINEM ROHRSTRANG IN EIN BOHRLOCH BESTIMMTE VORRICHTUNG
 DISPOSITIF ADAPTÉ POUR ÊTRE EXÉCUTÉ SUR UNE COLONNE DE TUBAGE DANS UN Puits DE FORAGE

(84) Designated Contracting States:
AL AT BE BG CH CY CZ DE DK EE ES FI FR GB GR HR HU IE IS IT LI LT LU LV MC MK MT NL NO PL PT RO RS SE SI SK SM TR

• **Busengdal, Paul David**
4032 Stavanger (NO)

(43) Date of publication of application:
28.08.2019 Bulletin 2019/35

(74) Representative: **Håmsø Patentbyrå AS**
P.O. Box 9
4068 Stavanger (NO)

(73) Proprietor: **Grant Prideco, Inc.**
Houston, TX 77036 (US)

(56) References cited:
WO-A1-2015/073001 GB-A- 2 125 470
US-A- 2 695 066 US-A- 5 181 569
US-A- 5 775 428 US-A- 5 810 084
US-A1- 2004 000 406 US-A1- 2010 032 167

(72) Inventors:
 • **Sørheim, Tore**
4072 Randaberg (NO)

Note: Within nine months of the publication of the mention of the grant of the European patent in the European Patent Bulletin, any person may give notice to the European Patent Office of opposition to that patent, in accordance with the Implementing Regulations. Notice of opposition shall not be deemed to have been filed until the opposition fee has been paid. (Art. 99(1) European Patent Convention).

EP 3 530 873 B1

Description

[0001] The present invention relates to a system comprising an actuating body and a device adapted to be run on a tubing string into a wellbore. The present invention also relates to a tubing string comprising said system. Also, the present invention relates to a method of running a tubing string to an intended depth in a wellbore having wellbore fluid inside.

[0002] In petroleum production, a usual task in the completion of a well is running a closed tubing string until a certain depth in the bore of the well. This task may be useful for various purposes, such as the installation of a production component.

[0003] Carrying out this task can be complex. On the one hand, since the operation costs are proportional to the duration of the trip, it is normally desired that the tubing string reaches the intended depth as quickly as possible. On the other hand, a high velocity of insertion can result in damage being caused to the tubing string. This scenario is strongly undesired, as it represents an additional cost for the completion of the well, which typically is a significant cost. Thus, it is wished that the tubing string runs as quickly as possible into the wellbore, but at the same time that the tubing string does not get damaged because of the trip to the intended depth.

[0004] During the trip, there is a phenomenon in particular that can cause problems to the closed tubing string: the creation of a surge of fluid towards the head of the well. Normally, the wellbore contains fluid inside during the completion phase. The submersion of the closed tubing string in that fluid displaces an amount of the second that is equal to the submerged volume. Consequently, the displaced fluid flows towards the head of the well through the available spaces, such as the annular space formed around the tubing string. This motion of the surging fluid can reach high velocities and be a cause of damage to the components that are on the tubing string. For example, it is possible that, due to the swabbing caused by the surging fluid, a packer element detaches from its respective packer device.

[0005] Thus, it can be challenging to run a tubing string into a wellbore without that motion resulting in a surging fluid capable of damaging the tubing string.

[0006] A known approach involves running the tubing string into the wellbore at a speed low enough that the surging fluid does not cause harm to the components on the tubing string.

[0007] This approach significantly increases the cost of the operation, as it requires more time in order to perform the trip.

[0008] Another known approach is to equip the components on the tubing string with stronger parts that can withstand the high velocities of the surging fluid. Some solutions in this respect include parts with different physical properties based on their glass transition temperature. For example, a production packer may include a packer element formed by such a material. In this case,

at temperatures above the glass transition temperature the material shows rubber-like characteristics, and at temperatures below the glass transition temperature it presents rigid characteristics. The material can exhibit a rigid form in zones of the wellbore, typically upper regions, in which the temperature is below the glass transition temperature, and the tubing string may thus be moved more quickly to its destination. And in zones of the wellbore in which the temperature is above the glass transition temperature, the material is more flexible and thus allows a sealing operation to occur. This approach can allow the expandable device to be moved in certain parts of a well, and it does not put in jeopardy the steps required for the installation task to the same extent. However, it can be technically challenging to provide an expandable device with a suitable temperature-based material. For example, since the flexibility of the material of the expandable device may depend on the temperature in the wellbore, the temperature may need to be monitored when moving the expandable device along the well.

[0009] Another known approach involves running only open tubing strings. It is expected that the fluid inside the wellbore can flow to the interior of the tubing string during the trip, such as through a free end of the tubing string. However, this approach requires carrying out additional tasks in order to remove the well fluids from the inside of the tubing string. For example, when installing a production packer it is often necessary to increase the pressure inside the tubing string so that the production packer expands and forms a seal against a surrounding surface. In order to install the production packer while having well fluids inside the tubing string, the following tasks can be carried out: pump the well fluids out of the tubing string into the wellbore and upwards through the annular space surrounding the tubing string; close the tubing string using a cement plug, which involves waiting for the cement to solidify; increase the pressure inside the tubing string until the production packer is set in place; and remove the cement plug. In sum, a lengthy procedure is required for this approach in order to compensate for the string having been run open into the wellbore.

[0010] Document US 5 181 569 A discloses a pressure operated valve in which there is a sleeve valve controlling flow between outside and inside the valve. Pressure on a ball sealingly engaging the sleeve operates the sleeve valve from open to latched closed to disconnect position and expands the sleeve valve from the housing. This solution is focused on dealing with time consumption and operation expenses drawbacks related to running tubing from surface into a well to install or expend a sealing plug from a packer, especially if long lengths of tubing must be run to reach a packer set deep in a well.

[0011] Document GB 2 125 470 A discloses a tool for use downhole in a borehole for carrying out a backsurging method. Backsurging has the purpose of more thoroughly cleaning out some of the perforations and unplug some perforations which may be clogged with debris. This solution is focused on backsurging a well with the control

valve being located as close as possible to the perforations.

[0012] Document US 2 695 066 A discloses a hydraulically actuated well tool, more particularly a well packer adapted to be anchored in a well bore as a result of subjecting the tool to fluid pressure. This solution is focused on allowing upward flow of fluid through a tool, during lowering of the tool in the well bore, by initially preventing the back pressure valve from seating.

[0013] The present invention will now be disclosed. The invention is set out in the appended set of claims.

[0014] The terms "downhole" and "uphole" are used herein to refer to the sense of placement or movement along a wellbore trajectory with respect to an entrance of the wellbore, "downhole" signifying away from and "uphole" signifying toward the entrance to the wellbore. Hence in the case of a deviating horizontal or inverted section of a wellbore, the term "downhole" can refer to a part of a string which due to the wellbore trajectory may travel upward or at the same elevation, or which due to the wellbore trajectory has the same elevation or a higher elevation than another part of the string. Conversely, the term "uphole" can refer to a part of the string which due to the wellbore trajectory may travel downward or at the same elevation, or which due to the wellbore trajectory has the same elevation or a lower elevation than another part of the string.

[0015] The invention will now be described, by way of example only, with reference to the accompanying drawings, in which:

Figure 1 is a schematic representation of an expandable device during deployment, according to the prior art;

Figure 2 is a part-sectional representation of an apparatus according to an embodiment of the present invention, where an expandable device is being installed;

Figures 3A to 3C are part-sectional representations of an apparatus according to another embodiment of the invention, at different stages of a process through which a valve is closed; and

Figures 4A to 4C are part-sectional representations of an apparatus at different stages of use to install an expandable device in a wellbore, according to another embodiment of the invention.

[0016] Turning first to look at Figure 2, apparatus 1 includes an expandable device in the form of a production packer 10, mounted on a production string 5. The production string 5 is being run into a wellbore 2 to install the production packer 10 in a desired location in the well-

bore 2. The string 5 is being immersed or moved downwards as indicated by arrow A in a vertical section of a wellbore 2 so that it may be installed at a location further downhole. The production packer 10 is moved progressively further into the wellbore 2 as the string 5 is extended from topsides, e.g. from a rig or platform, for instance by adding sections to the string 5 using topsides equipment on a rig or platform.

[0017] The production packer 10 is provided on a tubular body 11 which is incorporated into the string 5. The packer 10 has annular sealing elements 12 mounted on the tubular body 11, the sealing elements 12 extend circumferentially around the body 11. The sealing elements 12 are arranged so that they are expandable from a collapsed condition to an expanded condition in which the sealing elements 12 are urged radially into contact with a surrounding wall 3 of the wellbore 2 and form a fluid-tight, annular seal in the annulus 6 between the wall 3 and the tubing string 5.

[0018] In Figure 2, the packer 10 is in the collapsed condition, to facilitate run-in, and a small gap 8 is present between an outer surface of the packer 10 and the wall 3 of the wellbore 2. Once the intended location for installation of the packer 10 is reached, the packer 10 can then be expanded by appropriate activation, achieved for example by hydraulic pressure applied from the surface.

[0019] On a downhole side of the packer 10, the string 5 has an inlet 22 providing fluid communication into an interior 51 of the string 5. As the string 5 is immersed/moved into the wellbore 2, wellbore fluid downhole of the leading end 9 of the string 5 is displaced. The wellbore fluid will then typically travel along the wellbore 2 toward the surface, since the wellbore fluid will seek to escape on a pathway of least resistance toward a region of low pressure. Wellbore fluid downhole of the packer 10 is received in the interior 51 of the string 5 through the inlet 22 and has a fluid communication path, indicated by arrows C, from an outside of the string 5, through the inlet 22, and along the inside of the string 5 toward the surface or other topsides receiver. A further fluid communication path, indicated by arrows B, is provided for wellbore fluid along the string 5 through the annulus 6 and the gap 8, toward the surface (or other topsides receiver).

[0020] Thus, it can be appreciated that the provision of the inlet 22 provides a path for wellbore fluid to flow along the inside of the string 5 by entering through the inlet 22, as well as on the outside, where the fluid can flow along the outside of the string 5 and pass around the outside of packer 10 through the gap 8.

[0021] By way of the apparatus 1 in Figure 2, the need to allow displaced fluid to escape during the immersion is shared between the internal and external paths. Advantageously, this may facilitate reducing the impact of displacement fluids on the packer 10 during immersion and/or allow the packer 10 to be immersed at higher speeds than in typical prior art solutions. More specifically, the velocity of the fluid allowed to pass on the out-

side of the packer may be reduced, which may in turn also decrease the drag forces on the packer. The reduction of the drag forces may have an advantage that the packer may be moved at higher speeds in the wellbore without swabbing the surrounding surface of the wellbore wall.

[0022] Referring now to the Figure 2 example in further detail, it can be seen that the string 5 includes a flow sub 20 connected on the downhole side of the packer 10. The flow sub 20 also has a tubular body 23. The inlet 22 is provided on the flow sub 20 and comprises an aperture penetrating through the wall 21 of the tubular body 23.

[0023] The flow sub 20 includes a close mechanism 40 for closing the inlet 22. An example of the close mechanism is described further below with reference to Figures 3A to 3C. When the inlet is open, fluid communication through the aperture is obtained, and the internal pathway (arrows B) is obtained. When the inlet 22 is closed, a sleeve 42 is arranged to cover the aperture to prevent fluid communication therethrough. The flow sub 20 is run-in/immersed as seen in Figure 2 with the inlet open to provide the desired fluid communication through an internal pathway.

[0024] In the configuration exemplified in Figure 2, the flow sub 20 also has a destructible barrier 60, e.g. rupture body such as a glass burst disc, in a main bore of the tubular body 23. The destructible barrier 60 is mounted to the tubular body 23 toward a downhole end. At an appropriate stage during the completion of the well, the destructible barrier 60 can be destroyed by applying pressure in the fluid contained inside the tubing string 5 such that the disc yields and breaks. Destroying the barrier 60 opens up the main bore 23 for allowing production to take place and reservoir hydrocarbon fluid to travel through the inside of the string 5, through the bore of the tubular body 23 and tubular body 11 and toward the surface.

[0025] Although Figure 2 shows a vertical section of a wellbore where relative positions along the string can be described by terms "above" and "below", it will be appreciated that a wellbore can in general have sections which may be horizontal, vertical, or inclined, and even show a curvature. In all cases, the inlet 22 provides fluid communication with the interior of the tubing string so that the fluid in the wellbore in front of the packer 10 can enter the interior of the tubing string 5 when the packer 10 is moving towards a bottom of the wellbore. By way of the inlet 22 being disposed in front of the packer 10, the inlet 22 is capable of letting fluid into the tubing string 5 that would otherwise flow through the gap 8 in the annular space surrounding the packer 10 and thus increase the drag forces created thereupon.

[0026] The string 5 is run in with the inlet 22 in open configuration as shown in Figure 2 until the desired location for installation is reached. Once in location, the inlet 22 is closed, for allowing the packer 10 then to be expanded.

[0027] Before closing the inlet, the fluid inside the tubing string 5 is typically driven out through the inlet back

to the wellbore due to practical reasons.

[0028] With reference additionally to Figures 3A to 3C, the close mechanism 40 and process of closing the inlet 22 will be described further.

5 **[0029]** In Figure 3A, the flow sub 20 is in an open configuration where the inlet 22 is open and provides fluid communication through the aperture 24 in the wall of the tubular body 23, during run-in as described above in relation to Figure 2.

10 **[0030]** The flow sub 20 has first and second end portions 25a, 25b connected at either end to the tubular body 23. The first and second end portions 25a, 25c are adapted to allow connection to adjacent sections in the string 5. The sleeve 42 is housed on an inside of the tubular body 23, and can be activated to slide relative to the tubular body 23, along the longitudinal axis L toward a downhole end 31. The sleeve 42 has a seat 35 for receiving a ball dropped into the tubing string 5 from top-sides for activating the sleeve 42.

20 **[0031]** A spring 46 is arranged on an inside of the tubular body in an annular slot 47 formed between an inner wall 48 of the tubular body 23 and spring retainer 49. The spring 46 acts between abutment surfaces 26, 27 on the end portion 25a and the sleeve 42 respectively, so as to be arranged to exert an axial force on the sleeve 42 in the longitudinal direction. The spring 46 is in compression in Figure 3A so as to exert a push force against the sleeve 42 toward the downhole end 31.

25 **[0032]** The spring 46 is provided so that the sleeve closes spontaneously.

30 **[0033]** In Figure 3A, the sleeve 42 is held in fixed position relative to the body 23, against the force of the spring 46, by way of shear pins 61. The shear pins 61 are provided to fasten the sleeve 42 in the open position, as shown in Figure 3A. Each shear pin 61 protrudes radially inward from the wall of the tubular body 23 and has an end which is received in a formation in an outer surface of the sleeve 42, so that the pin 61 locks the sleeve 42 with respect to the tubular body 23. The shear pins 61 can therefore prevent the sleeve 42 from closing the inlet 22 during run in.

35 **[0034]** Since the spring 46 is in a compressed state, this arrangement stores potential energy in the spring 46 that may be released for the purpose of closing the sleeve when the shear pins are broken off.

40 **[0035]** In order to close the inlet 22, the sleeve 42 is activated by dropping a ball 55 from a top end of the tubing string 5 such that it passes downhole through an inside of the tubing string 5. The ball 55 may be driven by applied fluid pressure behind the ball 55 to urge it along the tubing string 5 toward the location of the seat 35. Fluid in the tubing string 5 ahead of the ball 55 may exit through the aperture 24 to prevent "hydraulic lock". The ball 55 passes down the internal bore 52 and lands on the seat 35 where it comes to rest and forms a fluid tight seal against the seat 35. The activation of the sleeve is initiated when the object lands on the seat in the tubing string.

[0036] Pressure inside the tubing string 5 in the region 57 is applied and exerts a force against the ball 55 such that shear pins 61 are sheared off and break. This frees the sleeve 42 and the sleeve 42 moves along the tubular body 23 to a closed position in which the sleeve 42 blocks the inlet 22 and prevents fluid communication through the inlet 22 into the interior of the tubing string 5. The sleeve 42 is urged along the tubular body 23 by the applied force and the force of the spring 46.

[0037] Figures 3B and 3C show the progressive movement of the sleeve 42 into the fully closed configuration as shown in Figure 3C, after the shear pins 61 are broken. In Figure 3C, the inlet 22 is totally obstructed by the sleeve 42, and no fluid communication is possible between the inside and the outside of the tubing string 5. It can be noted that the spring 46 increases in extension from Figure 3A to 3C.

[0038] In this example, the ball 55 is made of material that is fluid-dissolvable. The ball 55 is used initially to close the inlet 22 as described above, but after a time it dissolves in the presence of the fluid inside the tubing string 5 such that it is removed. Removal of the ball is useful because the bore 57 can then be opened up for allowing hydrocarbon production or other operations to be performed. When the ball 55 has dissolved and is no longer seated on the seat 35, the spring 46 alone urges the sleeve 42 to remain in position and keeps the inlet 22 closed, e.g. while production takes place.

[0039] In other embodiments, other objects, e.g. other drop objects such as darts or the like, may be delivered through the inside of the tubing string and utilised to activate the sleeve 42. Such objects may or may not be dissolvable.

[0040] It can also be appreciated that different close mechanisms may be employed in other embodiments to close the inlet 22. In sleeve-based mechanisms, the sleeve may be closed in many ways, and using a spring and shear pins as described above is only way of doing it. For example, electronic means may be provided to activate the sleeve in reaction to the landing of the object on the seat; the compressed spring may be replaced by any other solution that would push the sleeve to the closed position, such as a compressed fluid; instead of the spring, the space in the tubing string that is closed by the object on the seat may be used as a pressure chamber to push the sleeve to the closed position; or the shear pins may be replaced by a locking mechanism activated electronically. An advantage of the approach described with reference to Figures 3A to 3C, using a spring and shear pins, is that it can be simple to implement.

[0041] Turning then to Figures 4A to 4C, further stages of use are depicted through which the production packer 10 is expanded and tested, and the tubing string 5 is prepared for production.

[0042] Figure 4A firstly illustrates the inlet 22 in closed configuration as a result of closing the sleeve as explained in relation to Figures 3A-3C. The ball 55 is deployed in the tubing string 5, which in turn activates the

sleeve 42 and closes the inlet 22. The tubing string 5 is now extended so that the packer 10 is at the position in the wellbore at which it will be expanded to form a seal against the surrounding surface of the wellbore wall.

[0043] Figure 4B illustrates the production packer being expanded and tested. The pressure of fluid contained inside the tubing string in the region 57 is increased to hydraulically operate packer so that the sealing elements 12 expand and are brought into contact with the wall of the wellbore. In this example, the ball 55 remains on the seat 35 while the pressure in the region 57 is increased as required. However, in an alternative variant, the ball 55 may be removed before activating the packer 10, e.g. by letting it dissolve, and the region 57 may be pressurised up to activate the packer directly against a rupture body 60

[0044] Various tests are performed for checking the integrity of the seal provided by the packer 10. One test may be carried out by filling the tubing string with a dense fluid, such as heavy mud, and checking if the seal of the packer 10 holds the tubing string 5 in place against the wellbore wall. Another test may be carried out by filling or pressurising the annulus 6 above the packer 10 and checking if there any leakage across the seal.

[0045] When these tests are completed, the ball 55 is dissolved and the rupture body 60 is broken by pressurising the fluid in the region 57 as necessary, and the bore 52 for production of oil and gas is opened up as indicated in Figure 4C.

[0046] It can be appreciated that the region 57 of the interior of the tubing string 5 (uphole of the ball 55 or rupture body 60 and up to the top end of the string), provides in effect a chamber for containing fluid that can be pressurised from topsides equipment, e.g. by pumping a fluid into the tubing at the top of the wellbore. The chamber can facilitate both expanding the packer 10 by increasing the pressure inside the tubing string 5, and carrying out at least one test for making sure that the seal of the packer 10 is well formed, for example in accordance with a standard for the certification of well barriers.

[0047] If the ball 55 is composed of dissolvable material, at some point in time the object will disintegrate. Such disintegration may take place before the expandable device is expanded, after the expansion, or after the tests. In the end, the tubing string needs to be made ready for production. For this purpose, the rupture body 60 needs to be removed using a suitable method, such as by pressurising the fluid in the region 57 beyond the pre-designed rupture limits.

[0048] Figure 4C illustrates a final state, in which the ball 55 is not present because it has been dissolved, and the rupture body 60 is not present because it has been removed.

[0049] The invention may have some or all of the following advantages:

- reduction of the time and cost necessary for installing a packer or other expandable device in a wellbore;

- reduced drag forces created on packer elements when it is translated along a wellbore;
- ability to move the packer into position along a wellbore at higher speed;
- simple solution with relatively few components; and
- improvements in moving a packer along a wellbore without jeopardising the ability to expand the packer, test the seal formed, and preparing the tubing string for production.

Claims

1. A system (1) comprising:

- a device (20) adapted to be run on a tubing string (5) into a wellbore (2); and
- an actuating body (55),

wherein the device (20) comprises:

- a tubular body (11, 23) adapted to form a portion of the tubing string,
 - at least one inlet (22) for enabling the entry of a fluid into the tubing string (5), wherein the at least one inlet is at least one aperture (24) in a wall of the tubular body (11, 23);
 - a close mechanism (40) for closing the at least one inlet (22), wherein the close mechanism (40) comprises a movable member (42) that is movable from a first position, whereby fluid can be received from an outside of the tubing string (5) into the tubing string (5) through the at least one inlet (22), to a second position for closing the at least one inlet (22); and
 - a catcher (35) coupled to the movable member (42),
- wherein, in a configuration for immersing the tubing string (5) in a fluid inside the wellbore (2), the movable member (42) is in the first position and the at least one inlet (22) is open for letting the fluid enter the tubing string (5), wherein the close mechanism (40) is operable to close by means of the actuating body (55), wherein the movable member (42) is movable from the first position to the second position by a force exerted by the actuating body (55), the actuating body (55) being received in the catcher (35),
- wherein the catcher (35) receives the actuating body (55) in an internal bore of the device (20) and
- wherein the actuating body is an object (55) inserted into a top end of the tubing string (5), wherein the object (55) is fluid-dissolvable, such that, when the device has been run on a tubing string into a wellbore in the configuration for immersing the tubing string (5), and when the ob-

ject has been received in the catcher and the movable member (42) has been moved from the first position to the second position, the object dissolves after a time in the presence of the fluid that has entered into the tubing string (5) through the at least one inlet (22),

characterized in that the device comprises a destructible barrier positioned downhole in relation to the at least one inlet, wherein the destructible barrier isolates the interior of the tubing string for allowing fluid in the isolated interior of the tubing string to be pressurised when the at least one inlet is closed.

2. A system according to claim 1, wherein the destructible barrier is arranged to be destroyed by applying pressure in the isolated interior of the tubing string, so that a bore opens inside the tubing string.

3. A system according to any of the claims 1 to 2, wherein the movable member is a sliding sleeve.

4. A system according to any of the claims 1 to 3, wherein the object is a ball, and the catcher is a seat for receiving the ball.

5. A system according to any of the claims 1 to 4, wherein the device comprises at least one retaining device for retaining the movable member in an open position in the immersing configuration.

6. A system according to claim 5, wherein the close mechanism comprises at least one biasing means for closing the movable member spontaneously when the at least one retaining device is sheared so as to free the movable member.

7. A tubing string comprising a system as described in any of the preceding claims.

8. A tubing string according to claim 7, comprising at least one expandable device, wherein the device of the system is mounted downhole in relation to the at least one expandable device.

9. A method of running a tubing string (5) to an intended depth in a wellbore (2) having wellbore fluid inside, **characterised in that** the tubing string (5) is in accordance with any of the claims 7 or 8, and wherein the method comprises the following steps:

- providing the device (20) on the tubing string (5), the device (20) being in the immersing configuration;
- extending the tubing string (5) until it reaches the intended depth; and
- deploying the object (55) into the interior of the tubing string (5), by inserting the object (55) into

the top end of the tubing string (5), so that the close mechanism (40) of the device (20) is operated to close the at least one inlet (22) of the device (20).

10. A method according to claim 9, the method comprising applying pressure to fluid in the interior of the string to perform:

when the tubing string (5) is in accordance with claim 8:

- expanding an expandable device provided on the tubing string so as to form a seal against a surrounding surface; and
- performing at least one test for testing the seal formed by the expandable device, and/or

when the tubing string (5) of claim 7 or 8 comprises a system as described in claim 2:

- destroying the destructible barrier member so that the bore opens in the interior of the string.

Patentansprüche

1. Ein System (1), umfassend:

- eine Vorrichtung (20) zur Ausführung auf einem Rohrstrang (5) in ein Bohrloch (2); und
- einen Stellkörper (55),

wobei die Vorrichtung (20) umfasst:

- einen Rohrkörper (11, 23), der so ausgelegt ist, dass er einen Teil des Rohrstrangs bilden kann,
- mindestens einen Einlass (22), um den Eintritt eines Fluids in den Rohrstrang (5) zu ermöglichen, wobei der mindestens eine Einlass mindestens eine Öffnung (24) in einer Wand des Rohrkörpers (11, 23) ist;
- einen Verschlussmechanismus (40) zum Verschießen des mindestens einen Einlasses (22), wobei der Verschlussmechanismus (40) ein bewegliches Element (42) umfasst, das von einer ersten Position, in der Fluid von außerhalb des Rohrstrangs (5) durch den mindestens einen Einlass (22) in den Rohrstrang (5) aufgenommen werden kann, in eine zweite Position zum Verschießen des mindestens einen Einlasses (22) bewegbar ist; und
- einen Fänger (35), der mit dem beweglichen Element (42) verbunden ist, wobei in einer Konfiguration zum Eintauchen

des Rohrstrangs (5) in ein Fluid innerhalb des Bohrlochs (2) das bewegliche Element (42) in der ersten Position ist und der mindestens eine Einlass (22) offen ist, um das Fluid in den Rohrstrang (5) eintreten zu lassen,

wobei der Verschlussmechanismus (40) über den Stellkörper (55) geschlossen werden kann, wobei das bewegliche Element (42) durch eine von dem Stellkörper (55) ausgeübte Kraft von der ersten Position in die zweite Position bewegbar ist, wobei der Stellkörper (55) in dem Fänger (35) aufgenommen wird,

wobei der Fänger (35) den Stellkörper (55) in einer Innenbohrung der Vorrichtung (20) aufnimmt und

wobei der Stellkörper ein Objekt (55) ist, das in ein oberes Ende des Rohrstrangs (5) eingesetzt wird,

wobei das Objekt (55) durch ein Fluid auflösbar ist, so dass, wenn die Vorrichtung auf einem Rohrstrang in ein Bohrloch in der Konfiguration zum Eintauchen des Rohrstrangs (5) ausgeführt wurde, und wenn das Objekt in dem Fänger aufgenommen wurde und das bewegliche Element (42) von der ersten Position in die zweite Position bewegt wurde, sich das Objekt nach einer Zeit in Gegenwart des Fluids auflöst, das durch den mindestens einen Einlass (22) in den Rohrstrang (5) eingetreten ist,

dadurch gekennzeichnet, dass die Vorrichtung ein zerstörbares Hindernis umfasst, das in Bezug auf den mindestens einen Einlass weiter unten im Bohrloch angeordnet ist, wobei das zerstörbare Hindernis das Innere des Rohrstrangs trennt, damit das Fluid im getrennten Inneren des Rohrstrangs unter Druck gesetzt werden kann, wenn der mindestens eine Einlass geschlossen ist.

2. Ein System nach Anspruch 1, wobei das zerstörbare Hindernis so angeordnet ist, dass es durch Anlegen von Druck in dem getrennten Inneren des Rohrstrangs zerstört wird, so dass sich eine Bohrung im Inneren des Rohrstrangs öffnet.

3. Ein System nach einem der Ansprüche 1 bis 2, wobei das bewegliche Element ein Gleithülse ist.

4. Ein System nach einem der Ansprüche 1 bis 3, wobei das Objekt eine Kugel ist und der Fänger ein Sitz zur Aufnahme der Kugel ist.

5. Ein System nach einem der Ansprüche 1 bis 4, wobei die Vorrichtung mindestens eine Haltevorrichtung zum Halten des beweglichen Elements in einer geöffneten Position in der eingetauchten Konfiguration umfasst.

6. Ein System nach Anspruch 5, wobei der Verschlussmechanismus mindestens ein Vorspannmittel zum spontanen Verschließen des beweglichen Elements umfasst, wenn die mindestens eine Rückhaltevorrückung abgesichert wird, um das bewegliche Element freizugeben.

7. Ein Rohrstrang, umfassend ein System wie in einem der vorangehenden Ansprüche beschrieben.

8. Ein Rohrstrang nach Anspruch 7, der mindestens eine dehnbare Vorrichtung umfasst, wobei die Vorrichtung des Systems im Verhältnis zu der mindestens einen dehnbaren Vorrichtung weiter unten im Bohrloch angebracht ist.

9. Ein Verfahren zum Einfahren eines Rohrstrangs (5) bis zu einer beabsichtigten Tiefe in einem Bohrloch (2), in dem sich Bohrlochflüssigkeit befindet, **dadurch gekennzeichnet, dass** der Rohrstrang (5) einem der Ansprüche 7 oder 8 entspricht, und wobei das Verfahren die folgenden Schritte umfasst:

- Anbringen der Vorrichtung (20) an dem Rohrstrang (5), wobei sich die Vorrichtung (20) in der Eintauchkonfiguration befindet;
- Verlängern des Rohrstrangs (5), bis er die vorgesehene Tiefe erreicht; und
- Anwenden des Objekts (55) in dem Innere des Rohrstrangs (5) durch Einführen des Objekts (55) in das obere Ende des Rohrstrangs (5), so dass der Verschlussmechanismus (40) der Vorrichtung (20) betätigt wird, um den mindestens einen Einlass (22) der Vorrichtung (20) zu verschließen.

10. Ein Verfahren nach Anspruch 9, wobei das Verfahren das Ausüben von Druck auf ein Fluid im Inneren des Strangs umfasst, um Folgendes auszuführen:

wenn der Rohrstrang (5) dem Anspruch 8 entspricht:

- Dehnen einer dehnbaren Vorrichtung, die an dem Rohrstrang angebracht ist, um eine Abdichtung gegen eine umgebende Oberfläche zu bilden; und
- Durchführen von mindestens einem Test, um die von der dehnbaren Vorrichtung gebildeten Abdichtung zu überprüfen, und/oder

wenn der Rohrstrang (5) nach Anspruch 7 oder 8 ein System wie in Anspruch 2 beschrieben umfasst:

- Zerstören des zerstörbaren Hindernisses, so dass sich die Bohrung im Inneren des

Strangs öffnet.

Revendications

1. Un système (1) comprenant :

- un dispositif (20) adapté pour être exécuté sur une colonne de tubage (5) dans un puits de forage (2) ; et
- un corps de réglage (55),

dans lequel le dispositif (20) comprend :

- un corps tubulaire (11, 23) adapté pour former une portion de la colonne de tubage ,
- au moins une entrée (22) pour permettre l'entrée d'un fluide dans la colonne de tubage (5), dans lequel la au moins une entrée est au moins une ouverture (24) dans une paroi du corps tubulaire (11, 23) ;
- un mécanisme de fermeture (40) pour fermer la au moins une entrée (22), dans lequel le mécanisme de fermeture (40) comprend un membre mobile (42) qui peut être mu d'une première position, où un fluide peut être reçu à partir de l'extérieur de la colonne de tubage (5) vers l'intérieur de la colonne de tubage (5) à travers la au moins une entrée (22), vers une seconde position pour fermer la au moins une entrée (22) ; et
- un élément attrapeur (35) accouplé au membre mobile (42), dans lequel, dans une configuration pour l'immersion de la colonne de tubage (5) dans un fluide à l'intérieur du puits de forage (2), le membre mobile (42) est en première position et la au moins une entrée (22) est ouverte pour laisser le fluide entrer dans la colonne de tubage (5), dans lequel le mécanisme de fermeture (40) peut être exécuté pour fermer à travers le corps de réglage (55), dans lequel le membre mobile (42) peut être mu de la première position vers la seconde position par une force exercée par le corps de réglage (55), le corps de réglage (55) étant reçu dans l'élément attrapeur (35), dans lequel l'élément attrapeur (35) reçoit le corps de réglage (55) dans un alésage interne du dispositif (20) et dans lequel le corps de réglage est un objet (55) inséré dans une extrémité supérieure de la colonne de tubage (5), dans lequel l'objet (55) peut être dissous dans un fluide, tel que, lorsque le dispositif a été exécuté sur une colonne de tubage dans un puits de forage dans la configuration pour l'immersion de la colonne de tubage (5), et lorsque l'objet a

- été reçu dans l'élément attrapeur et le membre mobile (42) a été mu de la première position vers la seconde position, l'objet se dissout après un certain temps en présence du fluide qui est entré dans la colonne de tubage (5) à travers la au moins une entrée (22),
- caractérisé en ce que** le dispositif comprend une barrière destructible positionnée au fond du puits par rapport à la au moins une entrée, dans lequel la barrière destructible isole l'intérieur de la colonne de tubage pour permettre au fluide dans l'intérieur isolé de la colonne de tubage d'être mis sous pression lorsque la au moins une entrée est fermée.
2. Un système selon la revendication 1, dans lequel la barrière destructible est arrangée pour être détruite en faisant pression dans l'intérieur isolé de la colonne de tubage, tel qu'un alésage s'ouvre à l'intérieur de la colonne de tubage.
 3. Un système selon l'une quelconque des revendications 1 à 2, dans lequel le membre mobile est un manchon coulissant.
 4. Un système selon l'une quelconque des revendications 1 à 3, dans lequel l'objet est une boule, et l'élément attrapeur est un siège pour recevoir la boule.
 5. Un système selon l'une quelconque des revendications 1 à 4, dans lequel le dispositif comprend au moins un dispositif de retenue pour maintenir le membre mobile en position ouverte dans la configuration d'immersion.
 6. Un système selon la revendication 5, dans lequel le mécanisme de fermeture comprend au moins un moyen de polarisation pour fermer le membre mobile spontanément lorsque le au moins un dispositif de retenue est cisailé de manière à libérer le membre mobile.
 7. Une colonne de tubage comprenant un système tel que décrit dans l'une quelconque des revendications précédentes.
 8. Une colonne de tubage selon la revendication 7, comprenant au moins un dispositif expansible, dans lequel le dispositif du système est monté au fond du puits par rapport au au moins un dispositif expansible.
 9. Un procédé d'exécution d'une colonne de tubage (5) à une profondeur souhaitée dans un puits de forage (2) ayant du fluide de puits de forage à l'intérieur, **caractérisé en ce que** la colonne de tubage (5) est conforme à l'une quelconque des revendications 7 ou 8, et dans lequel le procédé comprend les étapes suivantes :
 - fournir le dispositif (20) sur la colonne de tubage (5), le dispositif (20) étant dans la configuration d'immersion ;
 - étendre la colonne de tubage (5) jusqu'à ce qu'elle atteigne la profondeur souhaitée ; et
 - déployer l'objet (55) dans l'intérieur de la colonne de tubage (5), en insérant l'objet (55) dans l'extrémité supérieure de la colonne de tubage (5), tel que le mécanisme de fermeture (40) du dispositif (20) soit exécuté pour fermer la au moins une entrée (22) du dispositif (20).
 10. Un procédé selon la revendication 9, le procédé comprenant mettre le fluide à l'intérieur de la colonne sous pression pour exécuter les étapes suivantes :
 - lorsque la colonne de tubage (5) est conforme à la revendication 8 :
 - étendre un dispositif expansible fourni sur la colonne de tubage de manière à former un joint contre une surface environnante ; et
 - exécuter au moins un test pour tester le joint formé par le dispositif expansible, et/ou
 - lorsque la colonne de tubage (5) de la revendication 7 ou 8 comprend un système tel que décrit dans la revendication 2 :
 - détruire le membre de la barrière destructible tel que l'alésage s'ouvre à l'intérieur de la colonne.

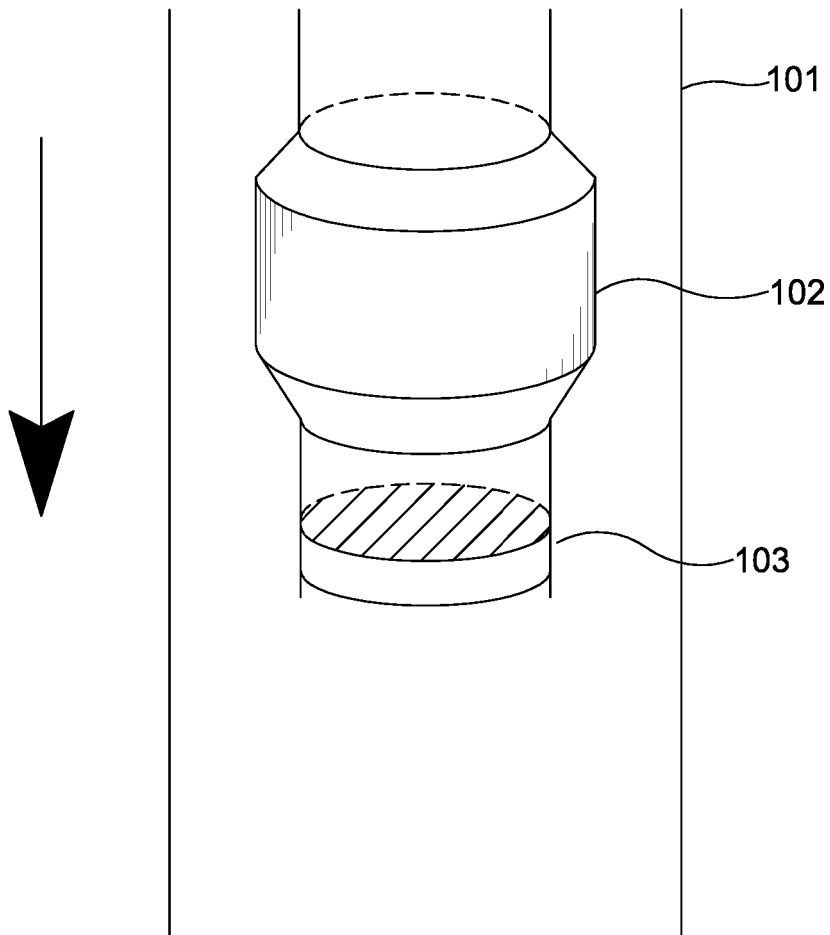

Fig. 1

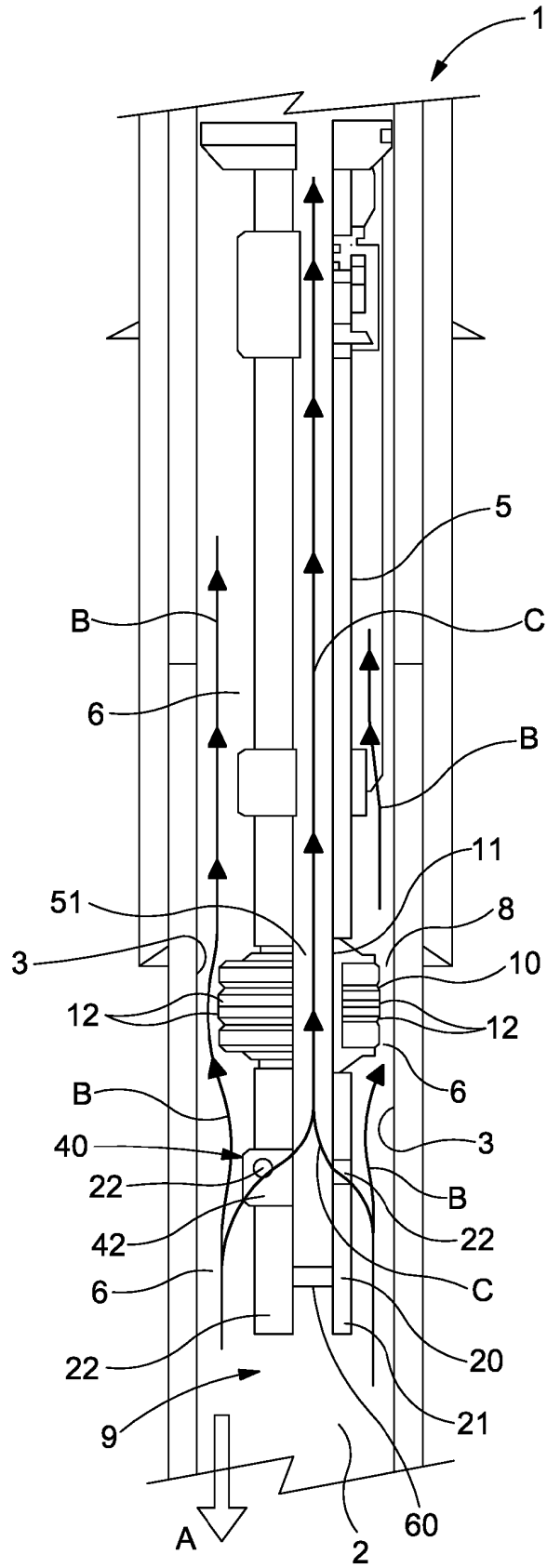

Fig. 2

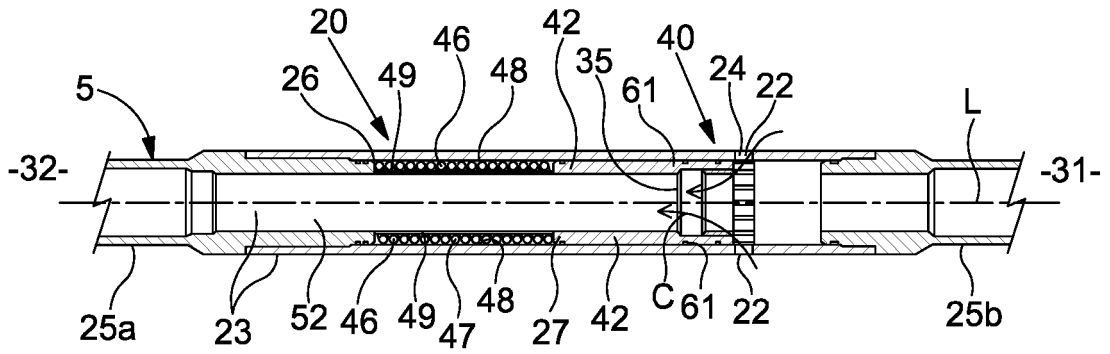

Fig. 3A

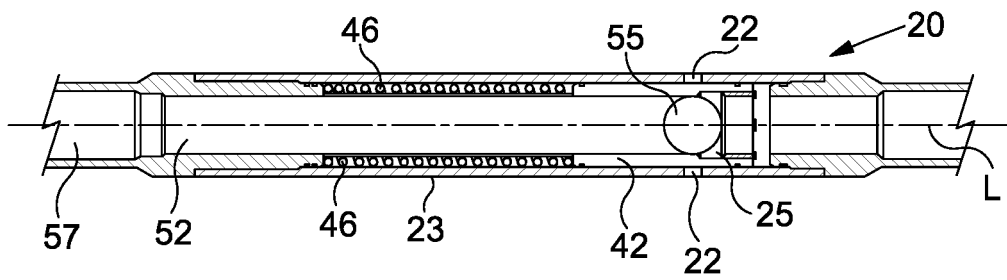

Fig. 3B

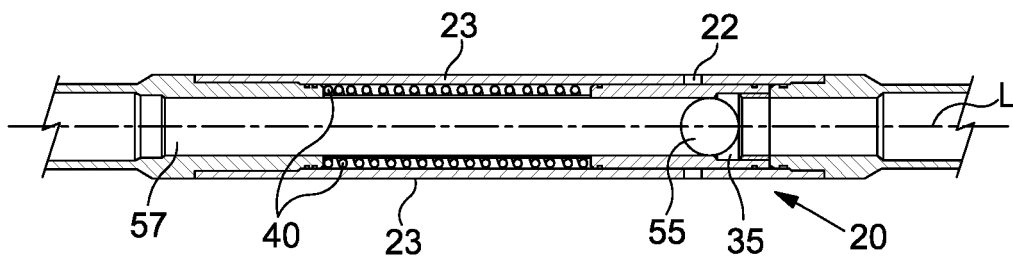

Fig. 3C

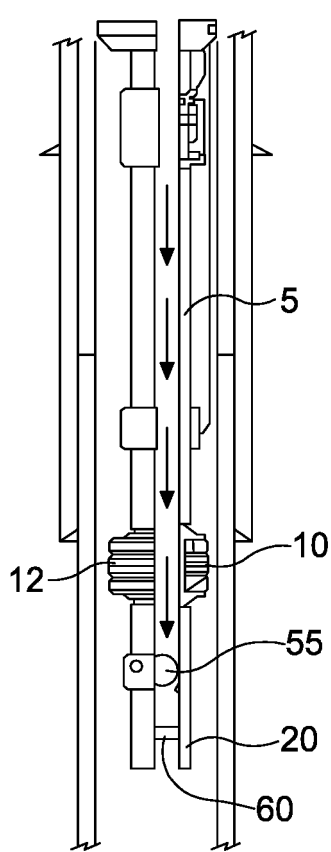

Fig. 4A

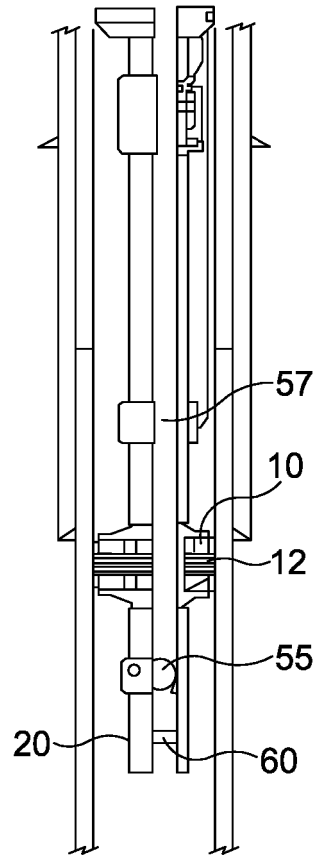

Fig. 4B

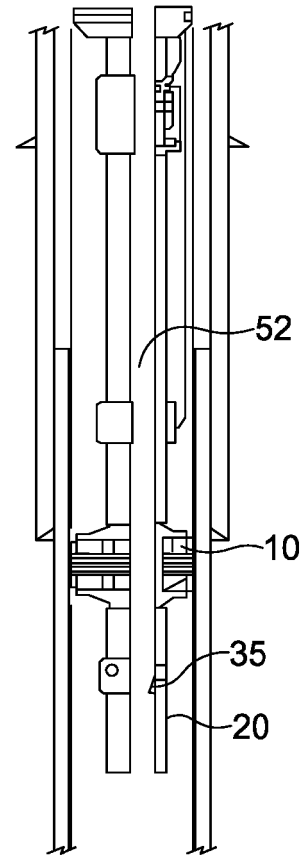

Fig. 4C

REFERENCES CITED IN THE DESCRIPTION

This list of references cited by the applicant is for the reader's convenience only. It does not form part of the European patent document. Even though great care has been taken in compiling the references, errors or omissions cannot be excluded and the EPO disclaims all liability in this regard.

Patent documents cited in the description

- US 5181569 A [0010]
- GB 2125470 A [0011]
- US 2695066 A [0012]