

J. C. GEPHART.

Bag Filler.

No. 104,297.

Patented June 14, 1870.

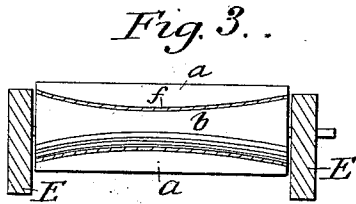
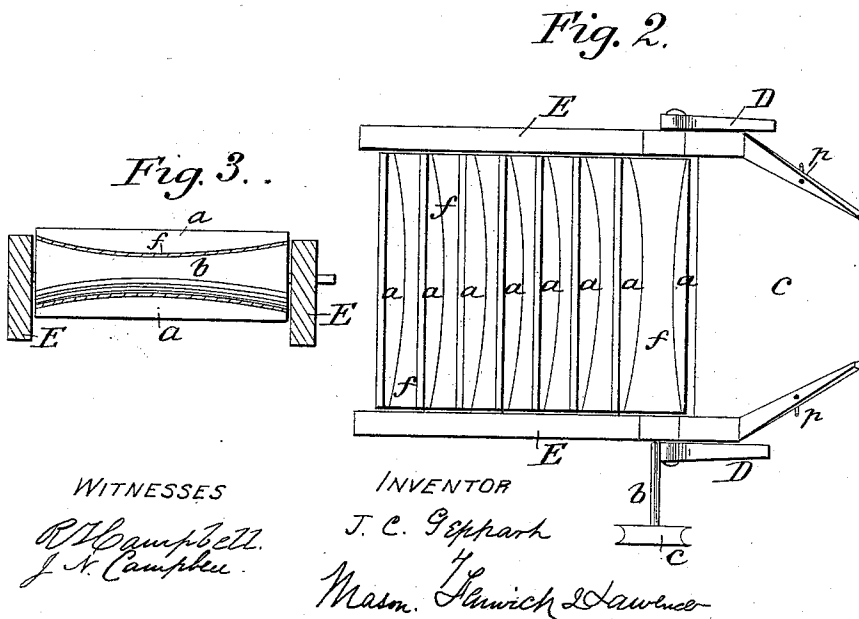
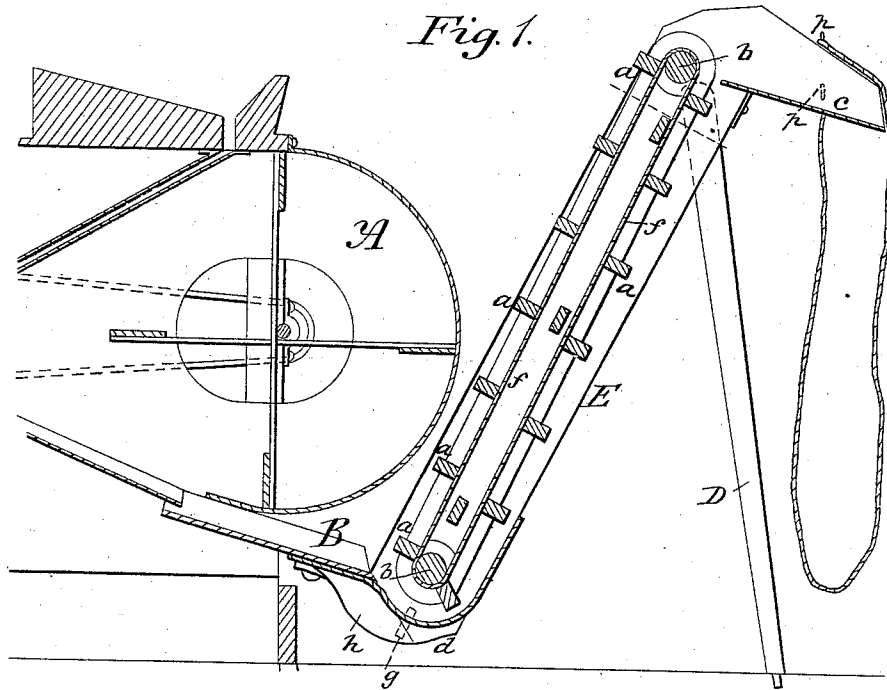

WITNESSES

*R. H. Campbell.*  
*J. N. Campbell.*

INVENTOR

*J. C. Gephart*  
*Wm. Smith Lawrence*

# United States Patent Office.

JACOB C. GEPHART, OF DOWAGIAC, MICHIGAN.

Letters Patent No. 104,297, dated June 14, 1870.

## IMPROVED BAG-FILLER FOR FANNING-MILLS.

The Schedule referred to in these Letters Patent and making part of the same.

To all whom it may concern:

Be it known that I, JACOB C. GEPHART, of Dowagiac, in the county of Cass and State of Michigan, have invented a new and improved Bag-Filler for Fanning-Mills; and I do hereby declare that the following is a full, clear, and exact description thereof, reference being had to the accompanying drawing making part of this specification, in which—

Figure 1 is a vertical sectional view of my improved bag-filler and a portion of a fanning-mill.

Figure 2 is a top view of the elevator and filler.

Figure 3 is a section taken transversely through the same.

Similar letters of reference indicate corresponding parts in the several figures.

The object of this invention is to afford great facility for filling bags with cleaned grain passing off from a fanning-mill.

It consists in constructing the endless apron, its slats, and the rollers around which said parts move, that the great mass of grain, while being elevated, will fall to the center of the apron, so as to be delivered in a narrow stream, instead of in a broad sheet as wide as the apron, as will be hereinafter explained.

To enable others skilled in the art to understand my invention I will explain its construction and operation.

In the accompanying drawing—

A represents a fanning-mill, for cleaning grain, which may be constructed in any of the well-known or improved ways, provided there is a discharge-shoe or spout, B, or equivalent, whereby the grain, as it escapes from such spout, can be received into and elevated to a proper height for delivering it into bags, as will be hereinafter explained.

The elevator and bag-holder consists of two side-boards, E E, of proper width and length, connected together by means of transverse bars, and provided, at its extremities, with rollers, *b b*, around which an endless slatted belt is applied.

The lower end of this frame is provided with holding-pins, *g*, and otherwise adapted for being attached to and supported by some part of the frame of a fan-

ning-mill, in such relation to the discharge end of the shoe of this mill that the grain, as it falls from this shoe, will be received upon the slatted belt or apron of the elevator and elevated.

The upper end of the said elevator-frame is provided with a spout, *c*, which may be constructed, more or less, at its discharge end, to adapt it for receiving the open ends of bags, and which is provided with hooks, buttons, or other equivalent devices, *s s*, by which bags can be readily secured to it, and held open while being filled with grain.

The props D are pivoted to the sides of the elevator-frame, and adapted for sustaining this frame at any desired angle.

The endless belt or apron, *f*, is fitted to run upon the concave rollers *b b*, so as to form a channel, toward the center of which all the grain which is received upon the apron will fall.

The transverse slats, brackets, or elevators, *a*, are similarly curved, so as to be adapted to the concave apron and rollers, as shown in figs. 2 and 3.

One end of the shaft, *b'*, of the upper roller *b*, is extended out and provided with a pulley, *c*, around which a belt is passed that is carried around a similar pulley on the fan-shaft of the mill. By this means motion is transmitted to the elevator-apron, and, by properly adjusting the size of the pulleys, with respect to the cleaning capacity of the mill, the grain will be carried off and bagged as rapidly as it is cleaned.

Having described my invention,

What I claim as new, and desire to secure by Letters Patent, is—

1. The combined bag-holder and elevator herein shown, consisting of spout *c*, in combination with concave rollers *b b*, apron *f*, and plano-convex slats *a*, substantially as and for the purpose herein set forth.

2. The plano-convex slats *a*, in combination with the apron *f*, substantially as and for the purpose set forth.

JACOB C. GEPHART.

Witnesses:

C. E. BAILEY,  
MYRON L. CULLOM.