



US00D857183S

(12) **United States Design Patent**
Sakae

(10) **Patent No.:** **US D857,183 S**

(45) **Date of Patent:** **** Aug. 20, 2019**

(54) HEAT EXCHANGER TUBE	2009/0195062 A1*	8/2009	Uchida	B62D 55/12 305/169
(71) Applicant: Kobe Steel, Ltd. , Kobe-shi (JP)	2010/0264799 A1*	10/2010	Liu	F21V 29/006 313/46
(72) Inventor: Akira Sakae , Kobe (JP)	2013/0048257 A1*	2/2013	Perry	F28D 1/04 165/154
(73) Assignee: Kobe Steel, Ltd. , Kobe-shi (JP)	2013/0062041 A1	3/2013	Sakae et al.	
(**) Term: 15 Years	2013/0292094 A1*	11/2013	Omori	F28D 15/025 165/104.21
(21) Appl. No.: 29/545,723	2014/0034278 A1*	2/2014	Lin	B23P 15/26 165/185

(Continued)

(22) Filed: **Nov. 16, 2015**

FOREIGN PATENT DOCUMENTS

(30) **Foreign Application Priority Data**

May 21, 2015 (JP) 2015-011156

(51) **LOC (12) Cl.** **23-03**

(52) **U.S. Cl.** **D23/323; D23/341**

(58) **Field of Classification Search**

USPC D23/314, 318, 322, 323, 332, 341;
D15/4, 6

CPC F28F 1/16; F28F 1/18; F28F 1/12; F28F
1/105; F28F 1/10; F28F 2255/16; F28F
1/20; B23P 15/26; B29C 47/908; F28D
1/00; Y10T 29/4938; Y10T 29/49378;
Y10T 29/49382; Y10T 29/49385

See application file for complete search history.

(56) **References Cited**

U.S. PATENT DOCUMENTS

1,821,434 A *	9/1931	Hamilton	F02F 1/06 123/41.68
2,826,672 A *	3/1958	Brown, Jr.	B21D 53/08 219/81
4,036,286 A *	7/1977	Anderson	E02D 3/115 165/45
9,448,012 B2 *	9/2016	Chen	F28F 1/40
9,906,001 B2 *	2/2018	Karandikar	H02B 1/56
2004/0190245 A1 *	9/2004	Tirumala	H01L 23/3672 361/690

JP	05-164496	6/1993	
JP	2005077035 A *	3/2005	C23C 28/00
WO	WO-2017016647 A1 *	2/2017	B23P 15/26 F16F 9/18

Primary Examiner — T Chase Nelson

Assistant Examiner — Ania Aman

(74) *Attorney, Agent, or Firm* — Oblon, McClelland,
Maier & Neustadt, L.L.P.

(57) **CLAIM**

The ornamental design for a heat exchanger tube, as shown and described.

DESCRIPTION

FIG. 1 is a perspective view of a heat exchanger tube;
FIG. 2 is a front view thereof;
FIG. 3 is a rear view thereof;
FIG. 4 is a left side view thereof, the opposite side being a mirror image of the side shown herein;
FIG. 5 is a top view thereof, the opposite side being an identical image of the side shown herein; and,
FIG. 6 is a cross-sectional view taken along line 6-6 in Fig. 2 thereof.

In the drawings, the broken lines depict unclaimed portions of the design only and form no part of the claimed design.

1 Claim, 6 Drawing Sheets

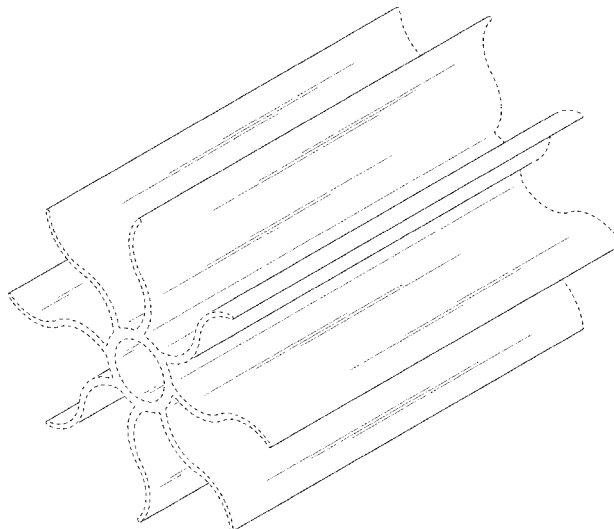

(56)

References Cited

U.S. PATENT DOCUMENTS

2015/0360332 A1* 12/2015 Singh F28D 7/10
29/890.046
2016/0010601 A1* 1/2016 Kinsey, Jr. F02M 35/02433
55/484
2017/0001943 A1* 1/2017 Gautam F28F 1/40
2017/0336073 A1* 11/2017 Weir F23J 15/06

* cited by examiner

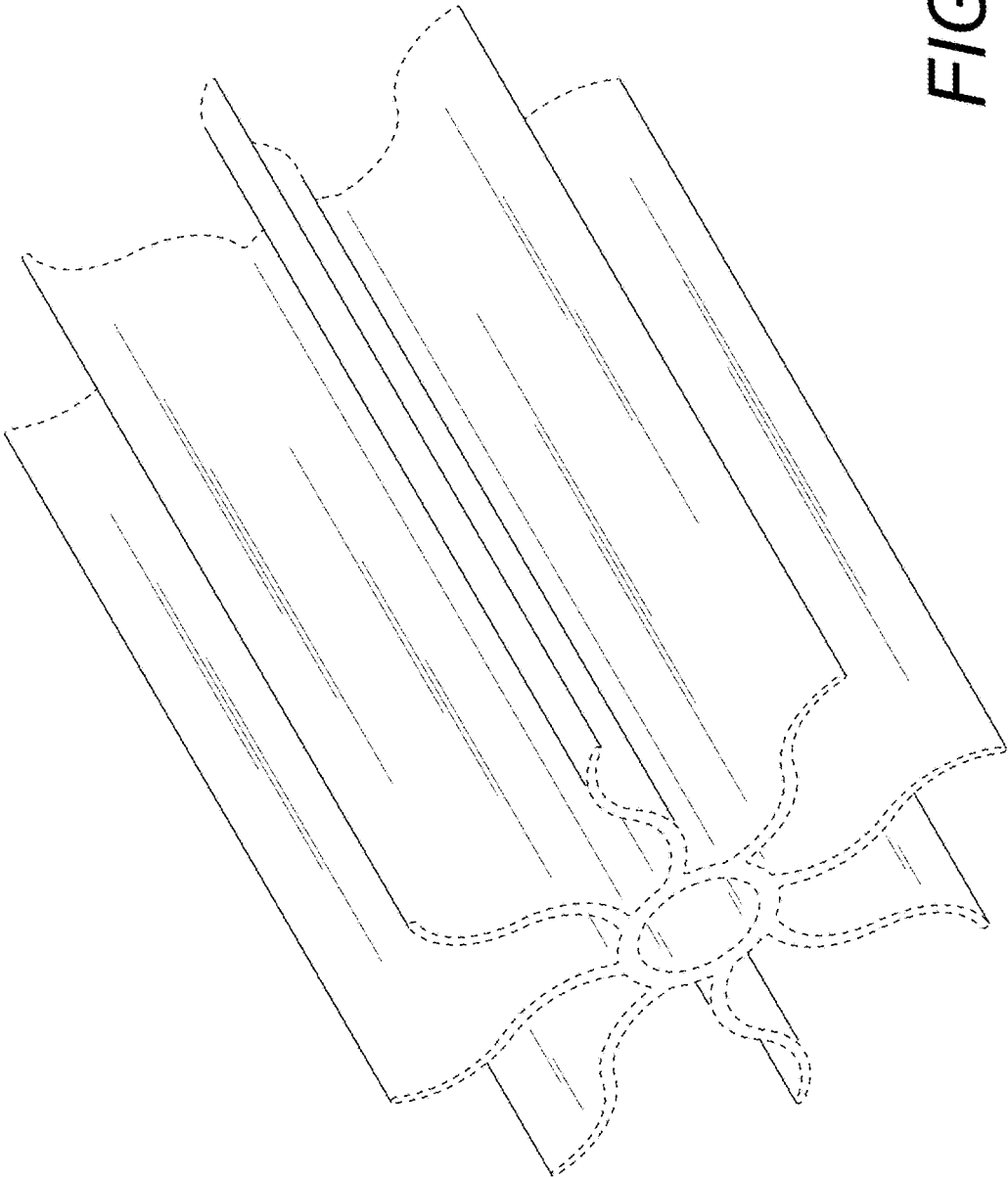
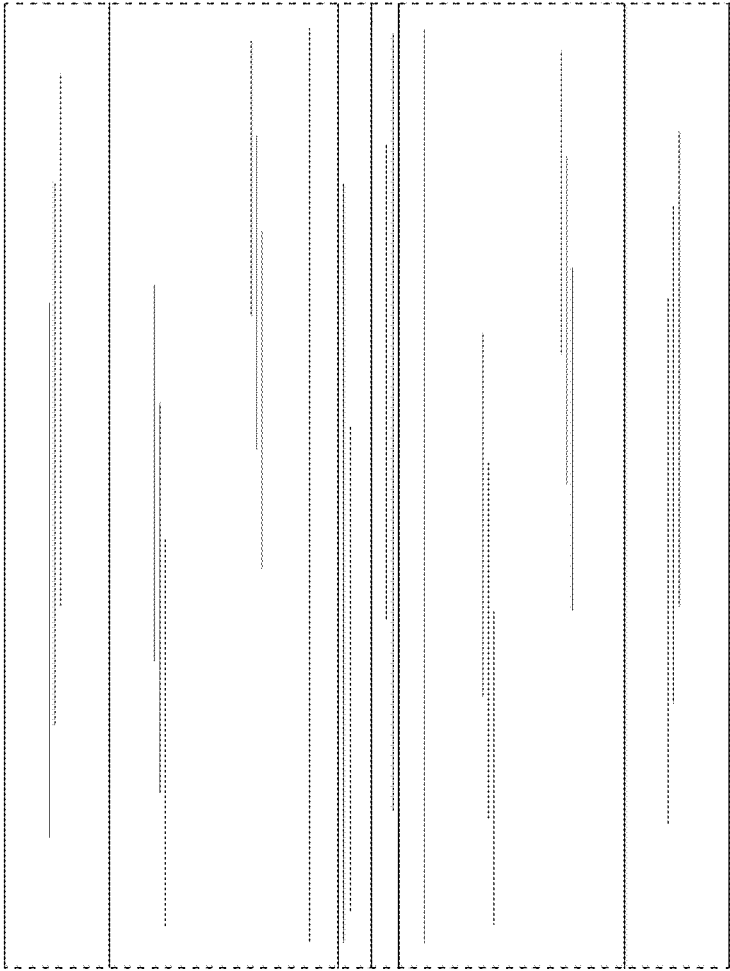

FIG. 1

6



6

FIG. 2

FIG. 4

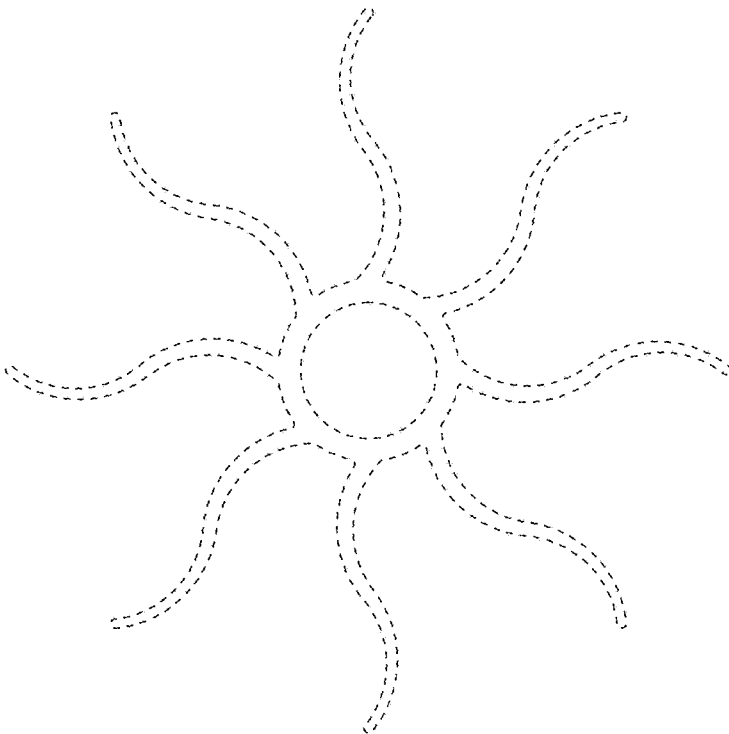

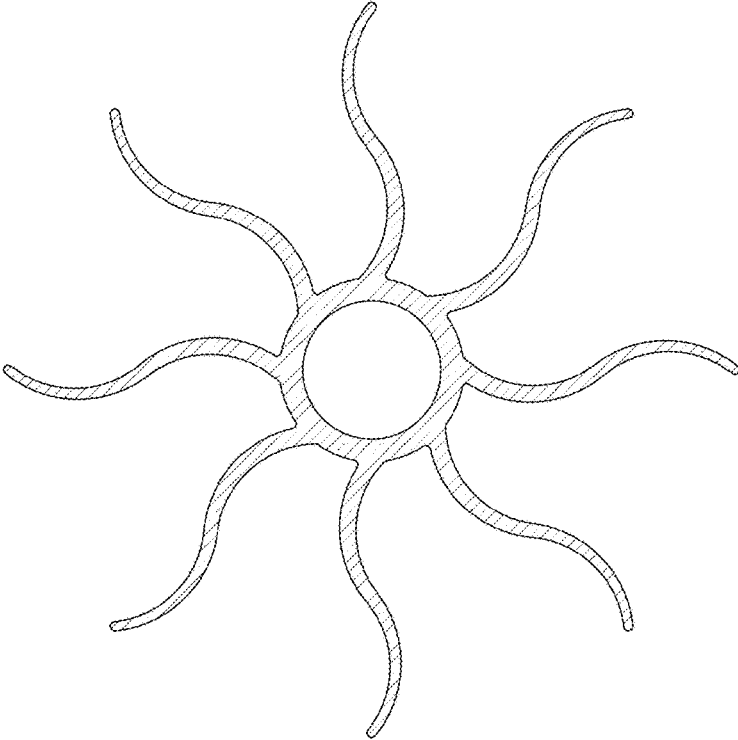

FIG. 6