



- (51) International Patent Classification:
H01Q 19/09 (2006.01) H01Q 19/13 (2006.01)
H01Q 19/10 (2006.01)
- (21) International Application Number:
PCT/US2014/020880
- (22) International Filing Date:
5 March 2014 (05.03.2014)
- (25) Filing Language: English
- (26) Publication Language: English
- (30) Priority Data:
61/773,757 6 March 2013 (06.03.2013) US
- (71) Applicant: MIMOSA NETWORKS, INC. [US/US]; 300 Orchard City Drive, Suite 100, Campbell, California 95008 (US).
- (72) Inventors: HINMAN, Brian L.; 300 Orchard City Drive, Suite 100, Campbell, California 95008 (US). MILLER, Wayne; 300 Orchard City Drive, Suite 100, Campbell, California 95008 (US). RAMOS, Carlos; 300 Orchard City Drive, Suite 100, Campbell, California 95008 (US).

- (74) Agents: SCHELLING, Myrna et al.; Carr & Ferrell LLP, 120 Constitution Drive, Menlo Park, California 94025 (US).
- (81) Designated States (unless otherwise indicated, for every kind of national protection available): AE, AG, AL, AM, AO, AT, AU, AZ, BA, BB, BG, BH, BN, BR, BW, BY, BZ, CA, CH, CL, CN, CO, CR, CU, CZ, DE, DK, DM, DO, DZ, EC, EE, EG, ES, FI, GB, GD, GE, GH, GM, GT, HN, HR, HU, ID, IL, IN, IR, IS, JP, KE, KG, KN, KP, KR, KZ, LA, LC, LK, LR, LS, LT, LU, LY, MA, MD, ME, MG, MK, MN, MW, MX, MY, MZ, NA, NG, NI, NO, NZ, OM, PA, PE, PG, PH, PL, PT, QA, RO, RS, RU, RW, SA, SC, SD, SE, SG, SK, SL, SM, ST, SV, SY, TH, TJ, TM, TN, TR, TT, TZ, UA, UG, US, UZ, VC, VN, ZA, ZM, ZW.
- (84) Designated States (unless otherwise indicated, for every kind of regional protection available): ARIPO (BW, GH, GM, KE, LR, LS, MW, MZ, NA, RW, SD, SL, SZ, TZ, UG, ZM, ZW), Eurasian (AM, AZ, BY, KG, KZ, RU, TJ, TM), European (AL, AT, BE, BG, CH, CY, CZ, DE, DK, EE, ES, FI, FR, GB, GR, HR, HU, IE, IS, IT, LT, LU, LV, MC, MK, MT, NL, NO, PL, PT, RO, RS, SE, SI, SK, SM,

[Continued on next page]

(54) Title: ENCLOSURE FOR RADIO, PARABOLIC DISH ANTENNA, AND SIDE LOBE SHIELDS

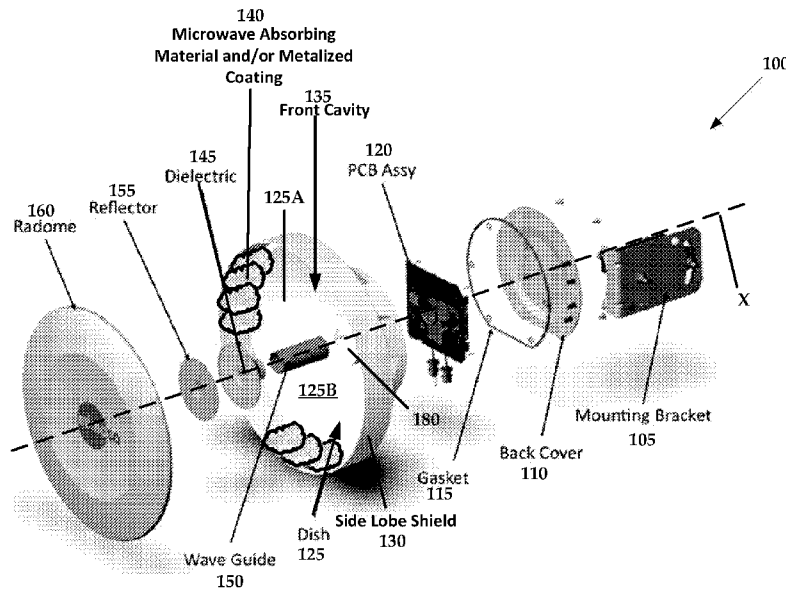

(57) Abstract: Enclosures for radios, parabolic dish antennas, and side lobe shields are provided herein. A dish antenna includes a parabolic circular reflector bounded by a side lobe shield that extends along a longitudinal axis of the dish antenna in a forward direction forming a front cavity, and a sidewall that extends along the longitudinal axis of the dish antenna in a rearward direction forming a rear cavity.

FIG. 1B

WO 2014/138292 A1

TR), OAPI (BF, BJ, CF, CG, CI, CM, GA, GN, GQ, GW, —
KM, ML, MR, NE, SN, TD, TG).

*before the expiration of the time limit for amending the
claims and to be republished in the event of receipt of
amendments (Rule 48.2(h))*

Published:

— *with international search report (Art. 21(3))*

ENCLOSURE FOR RADIO, PARABOLIC DISH ANTENNA, AND SIDE LOBE SHIELDS

CROSS REFERENCE TO RELATED APPLICATIONS

[0001] This non-provisional US application claims the priority benefit of provisional US application serial number 61/773,757, filed on March 6, 2013, titled "ENCLOSURE FOR RADIO, PARABOLIC DISH ANTENNA, AND SIDE LOBE SHIELDS", which is hereby incorporated by reference herein in its entirety including all reference cited therein.

FIELD OF THE INVENTION

[0002] The present technology is generally described as providing enclosures for a radio, parabolic dish antenna, and side lobe shields.

BACKGROUND

[0003] MIMO systems in general utilize multiple antennas at both the transmitter and receiver to improve communication performance. While not necessarily scaling linearly with antenna count, MIMO systems allow for the communication of different information on each of a plurality of antennas, generally using the same frequency, allowing a new dimension of scalability in high throughput communication. These MIMO systems exploit the use of spatial, polarization, time and/or frequency diversity to achieve orthogonality between multiple data streams transmitted simultaneously. Advanced downlink multi-user MIMO (MU-MIMO) systems takes advantage of the potential orthogonality between distinct receivers, allowing a single transmitter node to

communicate with multiple receiver nodes simultaneously, sending unique data streams per receiver. Uplink MU-MIMO systems are also possible, whereby multiple nodes can simultaneously send unique streams to one or more other nodes. Exemplary systems that utilize MIMO technology include, but are not limited to, Wi-Fi networks, wireless Internet service providers (ISP), worldwide interoperability for microwave access (WiMAX) systems, and 4G long-term evolution (LTE) data transmission systems.

SUMMARY

In some embodiments, the present technology is directed to devices that comprise a parabolic circular reflector bounded by a side lobe shield that extends along a longitudinal axis of the dish antenna in a forward direction forming a front cavity, and a sidewall that extends along the longitudinal axis of the dish antenna in a rearward direction forming a rear cavity. In some instances, the dish antenna is combined with a radio that transmits and/or receives signals.

[0004] In other embodiments the present technology is directed to dish antenna consisting of: a parabolic circular reflector bounded by a side lobe shield that extends along a longitudinal axis of the dish antenna in a forward direction forming a front cavity, and a sidewall that extends along the longitudinal axis of the dish antenna in a rearward direction forming a rear cavity, all manufactured as a monolithic structure.

BRIEF DESCRIPTION OF THE DRAWINGS

[0005] Certain embodiments of the present technology are illustrated by the accompanying figures. It will be understood that the figures are not necessarily to scale and that details not necessary for an understanding of the technology or that render other details difficult to perceive is omitted. It will be understood that the technology is not necessarily limited to the particular embodiments illustrated herein.

[0006] FIG. 1A are front and rear perspective views of an exemplary enclosure;

[0007] FIG. 1B is an exploded perspective view of the exemplary enclosure of FIG. 1A;

[0008] FIG. 1C is an exploded perspective view of the exemplary enclosure of FIGS. 1A-B, shown from the rear;

[0009] FIG. 2 illustrates an exemplary computing device that is used to implement embodiments according to the present technology.

DESCRIPTION OF EXEMPLARY EMBODIMENTS

[0010] While this technology is susceptible of embodiment in many different forms, there is shown in the drawings and will herein be described in detail several specific embodiments with the understanding that the present disclosure is to be considered as an exemplification of the principles of the technology and is not intended to limit the technology to the embodiments illustrated.

[0011] The terminology used herein is for the purpose of describing particular embodiments only and is not intended to be limiting of the invention. As used herein, the singular forms "a", "an" and "the" are intended to include the plural forms as well, unless the context clearly indicates otherwise. It will be further understood that the terms "comprises" and/or "comprising," when used in this specification, specify the presence of stated features, integers, steps, operations, elements, and/or components, but do not preclude the presence or addition of one or more other features, integers, steps, operations, elements, components, and/or groups thereof.

[0012] It will be understood that like or analogous elements and/or components, referred to herein, is identified throughout the drawings with like reference characters. It will be further understood that several of the figures are merely schematic representations of the present technology. As such, some of the components may have been distorted from their actual scale for pictorial clarity.

[0013] According to some embodiments, the present technology comprises a single piece of molded plastic which can house electronics for a radio, serve as a parabolic antenna when metalized, and provide rejection of radiation from adjacent antennas by forming a cylindrical metalized surface beyond the parabolic dish (e.g., side lobe shield). Devices of the present technology can be utilized in noisy environments, for example, a tower having multiple transmitters and receivers that are disposed proximately to one another. Devices of the present technology can be utilized to

effectively transmit and/or receive signals in these noisy environments in such a way that interference is reduced. These devices are be configured to reduce deleterious transmission and receipt of side lobe radiation from adjacent radiation generating devices, and enhance signal pickup. These and other advantages of the present technology will be described in greater detail herein.

[0014] FIGS. 1A-C collectively illustrate an exemplary device 100. FIG. 1A includes front and rear perspective views of a device 100 in an assembled configuration. The device 100 is provided with a dedicated that extends from a back cover 110 of the device 100.

[0015] FIG. 1B is an exploded perspective view of the device 100. Generally, the device 100 comprises a mounting bracket 105, a back cover 110, a gasket 115, a PCB (printed circuit board) assembly 120, a dish 125, a dielectric 145, a reflector 155, and a radome 160.

[0016] It will be understood that advantageously, the dish of the present technology is manufactured monolithically as one piece. That is, the dish 125 includes a parabolic circular reflector 125A that is bounded by the side lobe shield 130 to form the front cavity 135, and rear cavity 175. All these components are manufactured as a single device, as opposed to technologies where dishes are formed from separate components that are assembled in the field. Further, many dishes are an amalgamation of parts from a plurality of manufacturers, which can lead to physical incompatibility and on the fly modification in the field.

[0017] Advantageously, the monolithic dish provides advantages such as reduced manufacturing cost, since the dish can be manufactured in a single process. For example, the dish can be manufactured using injection molding, or any other similar process that is capable of producing a dish with the physical features as those illustrated in the drawings of the disclosure.

[0018] Another advantage of the monolithic structure is that it allows for storage and incorporation of necessary electronics for the antenna within the dish. For example, the PCB assembly 120 can be housed within the rear cavity 175. This places the PCB assembly 120 and waveguide 155 (discussed in greater detail below) in very close proximity to the parabolic circular reflector 125A, which reduces or eliminates signal attenuation of signals produced by the PCB assembly 120 that are directed through the waveguide 155 that would be present if the PCB assembly 120 and/or waveguide are not located proximate the parabolic circular reflector 125A.

[0019] The mounting bracket 105 that allows the device 100 to be pivotally coupled to a mounting surface, such as a tower (not shown). The ability of the device 100 to be pivotally connected to a mounting surface allows for an azimuth angle to be established, as would be known to one of ordinary skill in the art with the present disclosure before them. While the mounting bracket 105 has been described, the device 100 couples with a structure using any one or more of a number of mechanisms that would be apparent to one of ordinary skill in the art with the present disclosure before them. The mounting bracket 105 couples with a back cover via a plurality of fasteners. The mounting bracket 105 couples to the back cover 110 using fasteners.

[0020] In some embodiments, the mounting bracket 105 couples with a set of pole clamps that allow the device 100 to be clamped to a pole or other similar structure.

[0021] The device 100 also comprises a dish antenna 125 that is formed so as to include a rear cavity 175 (see FIG. 1C) and a front cavity 135. A PCB assembly 120 is disposed at least partially within the rear cavity of the dish. The PCB assembly 120 includes any circuits needed to operate the device 100. In some embodiments, the dish antenna 125 is a parabolic circular reflector 125A that is bounded by the side lobe shield 130 to form the front cavity 135. The front cavity extends forwardly from the dish.

[0022] The shape of the parabolic reflector depends upon the desired radiation pattern for the device 100. Thus, the exact shape and size of the parabolic circular reflector varies according to design and implementational requirements.

[0023] A seal, such as a gasket 115, is disposed between the outer peripheral edge of the rear cavity 175 and the back cover 110 to sealingly protect the PCB assembly 120 from contamination. The PCB assembly 120 also includes a PCB heat spreader 185 or other means for transferring heat generated by the PCB assembly 120 to the ambient environment such as fans and so forth.

[0024] In some instances, the dish 125 includes a side lobe shield 130 that extends beyond the outer peripheral edge of the dish 125. In some instances the side lobe shield 130 is a shroud having a sidewall that forms a ring around the outer peripheral edge of an upper surface of the dish 125. The side lobe shield 130 extends from the dish 125 axially along a longitudinal axis X of the device 100.

[0025] The dish 125, in some embodiments, is manufactured as a monolithic or one piece device. The dish 125 is manufactured from any one or combination of materials that are suitable for use as with an antenna.

[0026] Advantageously, the inner surface of the side lobe shield 130 is provided with a metalized coating. The upper surface 125B of the parabolic reflector 125A also includes a metalized coating. In some instances at least a portion of the inner surface of the side lobe shield is augmented with a metallic coating and/or a microwave absorbing material 140, such as a foam or other electrically insulating material that is coated along the inner surface of the front cavity 135 of the dish 125. For example, the material 140 lines the inner portion of the side lobe shield 130.

[0027] The upper surface 125B is generally circular and parabolic in shape, which aids in directing radiation along the longitudinal axis X. Again, the shape of the dish 125 functions to reduce emissions of side lobe radiation. In some embodiments, the

dish 125 has an annular shaped mounting ring 180 that is configured to receive the wave guide 150.

[0028] The microwave absorbing material 140 is shown as being disposed within the front cavity 135 in FIG. 1B, but can also be applied or sprayed to the inner surface of the side lobe shield 130. In other instances, the microwave absorbing material 140 is integrated into the side lobe shield 130 itself. That is, the side lobe shield 130 is manufactured as a layered or composite. For example, the side lobe shield 130 comprises a substrate of a metallic material that has a layer of microwave absorbing material applied thereto. Specifically, the absorbing material would be applied to a surface of the side lobe shield that is proximate the wave guide 150 of the device.

[0029] In other embodiments, a metalized coating is applied to the entire upper surface of the dish 125 and the inner sidewall of the side lobe shield 130.

[0030] Because the side lobe shield 130 extends beyond the outer peripheral edge of the dish 125, the side lobe shield 130 functions to direct the signals reflected by the dish surface in a more uniform and directed pattern. For example, the side lobe shield 130 reduces side lobe radiation which is transmitted from and/or received by the device 100. Thus, the device 100 reduces an amount of signals (e.g., radiation) which are received by the device 100 such as those transmitted by adjacent transmitters. Also, the side lobe shield 130 of the device 100 also reduces an amount of microwave signals transmitted via side lobe projection by the device 100. Thus, the device 100 reduces both the transmission and reception of deleterious side lobe signals.

[0031] The device 100 also comprises a wave guide 150 that is communicatively coupled with the PCB assembly 120. A cylindrical dielectric 145 plate couples with the wave guide 150. Also, a reflector 155 is associated with the dielectric plate 145. The combination of the PCB assembly 120, wave guide 150, dielectric plate 145, and reflector 155 are collectively referred to as a "radio." A radome cover 160 attaches to the side

lobe shield 130 to sealingly cover the reflector 155, dielectric 145, and wave guide 150 that are housed within the front cavity 135.

[0032] It will be understood that the radome 160, side lobe shield 130, dish 125, and back cover 110 of the device 100 is constructed from any suitable material such as a plastic, a polymeric material, a resin, a composite material, a natural material, or any other material that would be known to one of ordinary skill in the art.

[0033] According to some embodiments, the dish 125 and the side lobe shield 130 is manufactured as an integral unit. Moreover, the rear cavity 175 of the dish 125 is formed to provide a mounting surface for receiving the PCB assembly 120. The rear cavity 175 is formed by a sidewall 195 that extends rearwardly from the dish antenna 125 along the longitudinal axis X. The sidewall 195 extends in an opposing direction from the side lobe shield 130.

[0034] The dish 125, as an integral unit, is manufactured from a plastic material, a polymeric material, a resin, a composite material, or other suitable material that would be known to one of ordinary skill in the art with the present disclosure before them. As mentioned before, the inner sidewall of the side lobe shield 130 and the upper surface 125A of the dish 125 is metalized while the rear cavity 175 is not metalized.

Additionally, the side lobe shield 130 is provided with a microwave insulating material.

[0035] According to some embodiments, the dish antenna 125 comprises a series of fins 190. These fins 190 may extend from the rear cavity 175 upwardly to the edge of the side lobe shield 130. More specifically, the series of fins extends upwardly from the sidewall of the rear cavity along an underside of the parabolic circular reflector or dish 125.

[0036] FIG. 2 illustrates an exemplary computing device 200 that is used to implement an embodiment of the present technology. The computing device 200 of FIG. 2 includes one or more processors 210 and memory 220. The computing device 200 is utilized to control one or more functions via the PCB assembly of device 100 of FIG. 1.

In some instances, the processor 210 and memory 220 is integrated into the PCB assembly 120. Exemplary functions executed by the processor 210 and stored in memory 220 includes, but are not limited to transmission and/or receipt of signals, as well as signal processing commonly utilized with 2X2 (or greater) multiple input, multiple output (MIMO) transceivers.

[0037] The Main memory 220 stores, in part, instructions and data for execution by processor 210. Main memory 220 can store the executable code when the system 200 is in operation. The system 200 of FIG. 2 further includes a mass storage device 230, portable storage medium drive(s) 240, output devices 250, user input devices 260, a graphics display 270, and other peripheral devices 280.

[0038] The components shown in FIG. 2 are depicted as being connected via a single bus 290. The components are connected through one or more data transport means. Processor unit 210 and main memory 220 is connected via a local microprocessor bus, and the mass storage device 230, peripheral device(s) 280, portable storage device 240, and graphics display 270 is connected via one or more input/output (I/O) buses.

[0039] Mass storage device 230, which is implemented with a magnetic disk drive, an optical disk drive, and/or a solid-state drive is a non-volatile storage device for storing data and instructions for use by processor unit 210. Mass storage device 230 can store the system software for implementing embodiments of the present technology for purposes of loading that software into main memory 220.

[0040] Portable storage device 240 operates in conjunction with a portable non-volatile storage medium, such as a floppy disk, compact disk or digital video disc, to input and output data and code to and from the computing device 200 of FIG. 2. The system software for implementing embodiments of the present technology is stored on such a portable medium and input to the computing device 200 via the portable storage device 240.

[0041] Input devices 260 provide a portion of a user interface. Input devices 260 includes an alphanumeric keypad, such as a keyboard, for inputting alphanumeric and other information, or a pointing device, such as a mouse, a trackball, stylus, or cursor direction keys. Additionally, the system 200 as shown in FIG. 2 includes output devices 250. Suitable output devices include speakers, printers, network interfaces, and monitors.

[0042] Graphics display 270 includes a liquid crystal display (LCD) or other suitable display device. Graphics display 270 receives textual and graphical information, and processes the information for output to the display device.

[0043] Peripheral 280 includes any type of computer support device to add additional functionality to the computing device. Peripheral device(s) 280 includes a modem or a router.

[0044] The components contained in the computing device 200 of FIG. 2 are those typically found in computing devices that is suitable for use with embodiments of the present technology and are intended to represent a broad category of such computer components that are well known in the art. Thus, the computing device 200 of FIG. 2 can be a personal computer, hand held computing device, telephone, mobile computing device, workstation, server, minicomputer, mainframe computer, or any other computing device. The computer can also include different bus configurations, networked platforms, multi-processor platforms, etc. Various operating systems can be used including UNIX, Linux, Windows, Macintosh OS, Palm OS, and other suitable operating systems.

[0045] Some of the above-described functions is composed of instructions that are stored on storage media (e.g., computer-readable medium). The instructions is retrieved and executed by the processor. Some examples of storage media are memory devices, tapes, disks, and the like. The instructions are operational when executed by

the processor to direct the processor to operate in accord with the technology. Those skilled in the art are familiar with instructions, processor(s), and storage media.

[0046] It is noteworthy that any hardware platform suitable for performing the processing described herein is suitable for use with the systems and methods provided herein. Computer-readable storage media refer to any medium or media that participate in providing instructions to a central processing unit (CPU), a processor, a microcontroller, or the like. Such media may take forms including, but not limited to, non-volatile and volatile media such as optical or magnetic disks and dynamic memory, respectively. Common forms of computer-readable storage media include a floppy disk, a flexible disk, a hard disk, magnetic tape, any other magnetic storage medium, a CD-ROM disk, digital video disk (DVD), any other optical storage medium, RAM, PROM, EPROM, a FLASH EPROM, any other memory chip or cartridge.

[0047] Computer program code for carrying out operations for aspects of the present invention is written in any combination of one or more programming languages, including an object oriented programming language such as Java, Smalltalk, C++ or the like and conventional procedural programming languages, such as the "C" programming language or similar programming languages. The program code may execute entirely on the user's computer, partly on the user's computer, as a stand-alone software package, partly on the user's computer and partly on a remote computer or entirely on the remote computer or server. In the latter scenario, the remote computer is coupled with the user's computer through any type of network, including a local area network (LAN) or a wide area network (WAN), or the connection is made to an external computer (for example, through the Internet using an Internet Service Provider).

[0048] The corresponding structures, materials, acts, and equivalents of all means or step plus function elements in the claims below are intended to include any structure, material, or act for performing the function in combination with other claimed elements as specifically claimed. The description of the present invention has been presented for

purposes of illustration and description, but is not intended to be exhaustive or limited to the invention in the form disclosed. Many modifications and variations will be apparent to those of ordinary skill in the art without departing from the scope and spirit of the invention. Exemplary embodiments were chosen and described in order to best explain the principles of the present technology and its practical application, and to enable others of ordinary skill in the art to understand the invention for various embodiments with various modifications as are suited to the particular use contemplated.

[0049] Aspects of the present invention are described above with reference to flowchart illustrations and/or block diagrams of methods, apparatus (systems) and computer program products according to embodiments of the invention. It will be understood that each block of the flowchart illustrations and/or block diagrams, and combinations of blocks in the flowchart illustrations and/or block diagrams, can be implemented by computer program instructions. These computer program instructions is provided to a processor of a general purpose computer, special purpose computer, or other programmable data processing apparatus to produce a machine, such that the instructions, which execute via the processor of the computer or other programmable data processing apparatus, create means for implementing the functions/acts specified in the flowchart and/or block diagram block or blocks.

[0050] These computer program instructions may also be stored in a computer readable medium that can direct a computer, other programmable data processing apparatus, or other devices to function in a particular manner, such that the instructions stored in the computer readable medium produce an article of manufacture including instructions which implement the function/act specified in the flowchart and/or block diagram block or blocks.

[0051] The computer program instructions may also be loaded onto a computer, other programmable data processing apparatus, or other devices to cause a series of

operational steps to be performed on the computer, other programmable apparatus or other devices to produce a computer implemented process such that the instructions which execute on the computer or other programmable apparatus provide processes for implementing the functions/acts specified in the flowchart and/or block diagram block or blocks.

[0052] The flowchart and block diagrams in the Figures illustrate the architecture, functionality, and operation of possible implementations of systems, methods and computer program products according to various embodiments of the present invention. In this regard, each block in the flowchart or block diagrams may represent a module, segment, or portion of code, which comprises one or more executable instructions for implementing the specified logical function(s). It should also be noted that, in some alternative implementations, the functions noted in the block may occur out of the order noted in the figures. For example, two blocks shown in succession may, in fact, be executed substantially concurrently, or the blocks may sometimes be executed in the reverse order, depending upon the functionality involved. It will also be noted that each block of the block diagrams and/or flowchart illustration, and combinations of blocks in the block diagrams and/or flowchart illustration, can be implemented by special purpose hardware-based systems that perform the specified functions or acts, or combinations of special purpose hardware and computer instructions.

[0053] While various embodiments have been described above, it should be understood that they have been presented by way of example only, and not limitation. The descriptions are not intended to limit the scope of the technology to the particular forms set forth herein. Thus, the breadth and scope of a preferred embodiment should not be limited by any of the above-described exemplary embodiments. It should be understood that the above description is illustrative and not restrictive. To the contrary, the present descriptions are intended to cover such alternatives, modifications, and

equivalents as is included within the spirit and scope of the technology as defined by the appended claims and otherwise appreciated by one of ordinary skill in the art. The scope of the technology should, therefore, be determined not with reference to the above description, but instead should be determined with reference to the appended claims along with their full scope of equivalents.

CLAIMS

What is claimed is:

1. A dish antenna, comprising: a parabolic circular reflector bounded by a side lobe shield that extends along a longitudinal axis of the dish antenna in a forward direction forming a front cavity, and a sidewall that extends along the longitudinal axis of the dish antenna in a rearward direction forming a rear cavity.

2. The dish antenna according to claim 1, wherein the dish antenna is manufactured as a monolithic structure.

3. The dish antenna according to claim 1, further comprising a radio associated with the dish.

4. The dish antenna according to claim 1, further comprising a printed circuit board assembly that generates signals that are directed through a wave guide that is disposed in a center of the dish antenna, wherein the printed circuit board assembly is disposed in the rear cavity in such a way that the printed circuit board assembly and the wave guide are placed in close proximity to the parabolic circular reflector.

5. The dish antenna according to claim 4, wherein the parabolic circular reflector includes an annular mounting ring and the wave guide is received within the annular mounting ring.

6. The dish antenna according to claim 5, wherein the wave guide is tubular and extends along the longitudinal axis of the dish.

7. The dish antenna according to claim 6, further comprising a circular dielectric plate configured to mate with the wave guide in such a way that the dielectric plate is spaced apart from the upper surface of the dish antenna.

8. The dish antenna according to claim 7, further comprising a reflector dish that is disposed on top of the dielectric plate.

9. The dish antenna according to claim 8, further comprising a radome cover that encloses the reflector dish, dielectric plate, and wave guide within a front cavity of the dish antenna formed by the upper surface of the dish antenna and the side lobe shield, wherein the radome cover mates with the side lobe shield.

10. The dish antenna according to claim 1, wherein the dish antenna comprises a back cavity that receives a printed circuit board assembly, the printed circuit board assembly comprising the radio.

11. The dish antenna according to claim 10, further comprising a back cover that encloses the printed circuit board assembly within the rear cavity.

12. The dish antenna according to claim 11, further comprising a heat spreader that is coupled to the printed circuit board assembly.

13. The dish antenna according to claim 1, wherein the front cavity is provided with a metallic coating.

14. The dish antenna according to claim 1, further comprising a microwave absorbing material that coats an inner surface of the side lobe shield.

15. The dish antenna according to claim 1, further comprising a series of fins that extend upwardly from the sidewall of the rear cavity along an underside of the parabolic circular reflector.

16. A dish antenna, consisting of: a parabolic circular reflector bounded by a side lobe shield that extends along a longitudinal axis of the dish antenna in a forward direction forming a front cavity, and a sidewall that extends along the longitudinal axis of the dish antenna in a rearward direction forming a rear cavity, all manufactured as a monolithic structure.

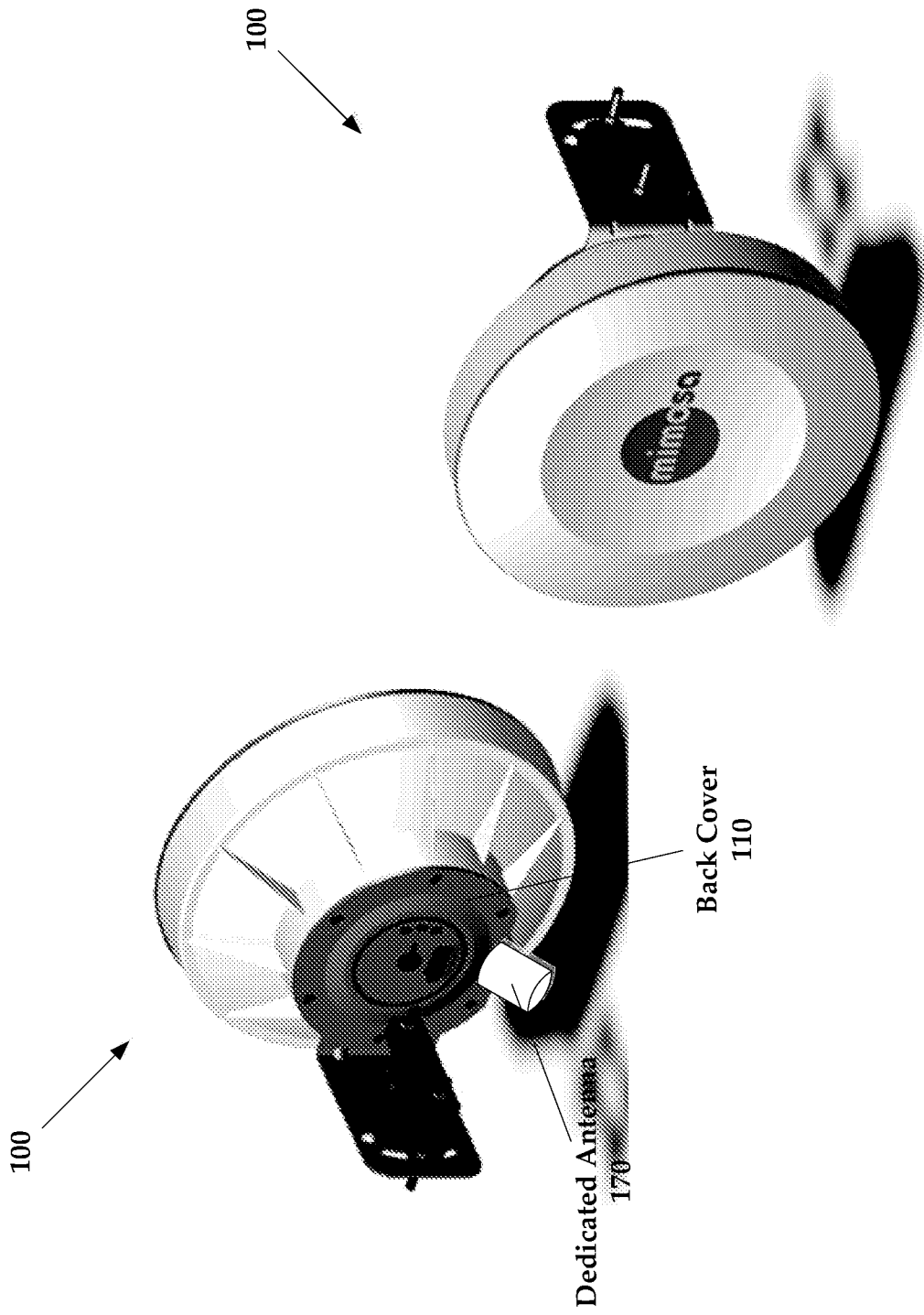

FIG. 1A

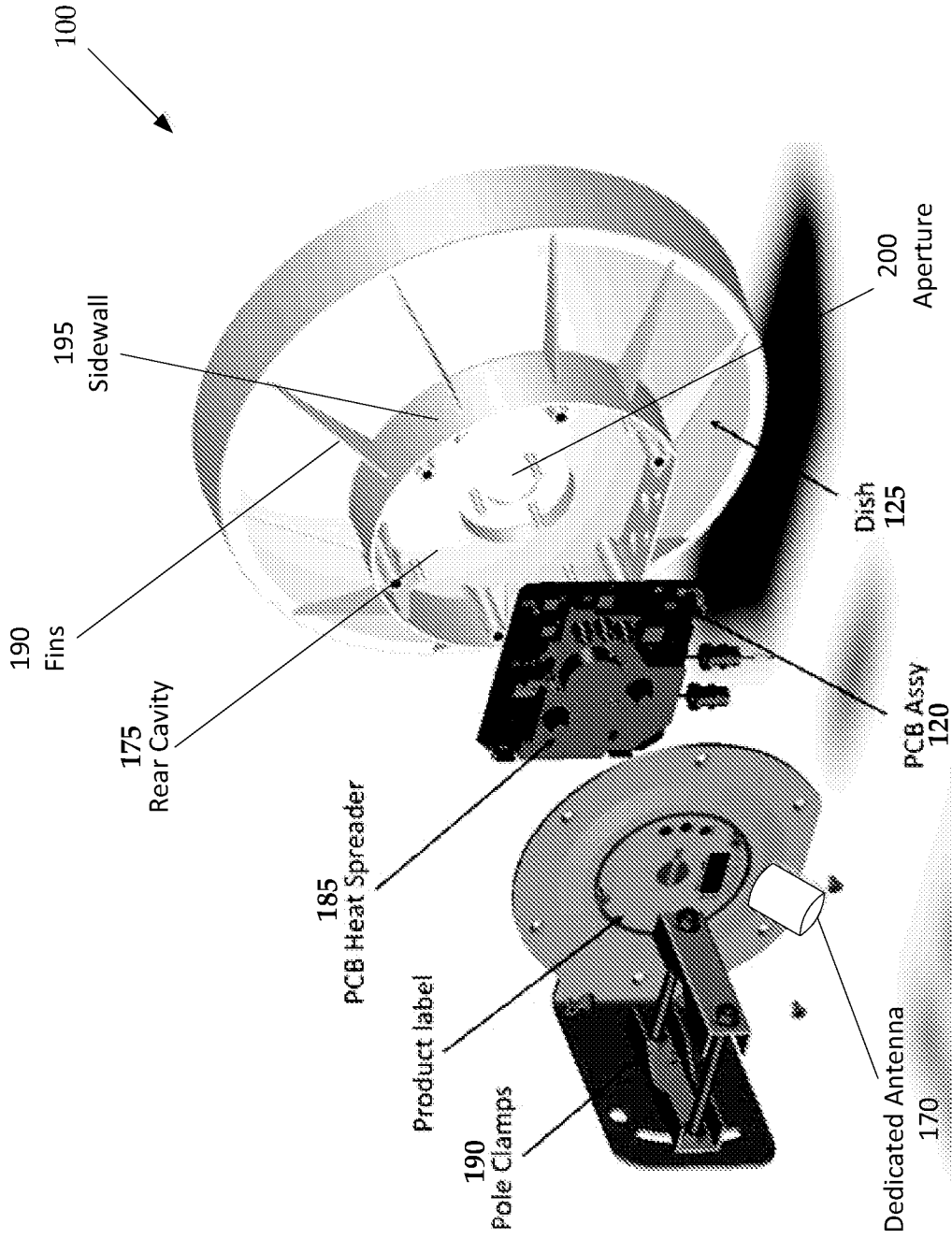

FIG. 1C

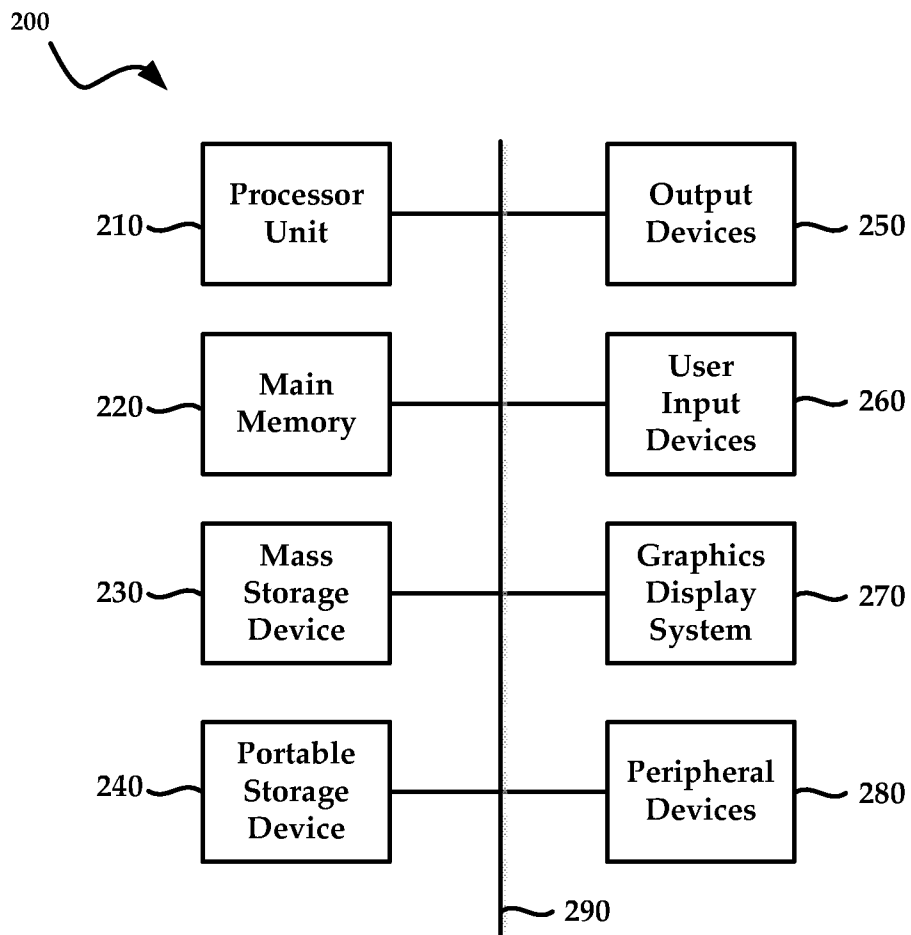

FIG. 2

INTERNATIONAL SEARCH REPORT

International application No.
PCT/US14/20880

A. CLASSIFICATION OF SUBJECT MATTER IPC(8) - H01Q 19/09, 19/10, 19/13 (2014.01) USPC - 343/702, 730, 872 According to International Patent Classification (IPC) or to both national classification and IPC		
B. FIELDS SEARCHED Minimum documentation searched (classification system followed by classification symbols) IPC(8)- H01Q 19/09, 19/10, 19/13 (2014.01) USPC-343/702, 730, 872 Documentation searched other than minimum documentation to the extent that such documents are included in the fields searched Electronic data base consulted during the international search (name of data base and, where practicable, search terms used) MicroPatent (US-G, US-A, EP-A, EP-B, WO, JP-bib, DE-C,B, DE-A, DE-T, DE-U, GB-A, FR-A); Google Patent/Google Scholar; IP.com; IEEE.org; parabolic, side lobe, antenna, dish, reflect*, circuit, PCB, circui*, radome, enclos*, printed circuit, wave guide		
C. DOCUMENTS CONSIDERED TO BE RELEVANT		
Category*	Citation of document, with indication, where appropriate, of the relevant passages	Relevant to claim No.
X — Y	US 7,616,959 B2 (SPENIK, J et al.) November 10, 2009, Figure 1, column 3, lines 37-40, column 4, lines 4-6, column 6, lines 43-46	1-3, 13, 16 <hr/> 4-12, 14-15
Y	US 2008/0242342 A1 (ROFOUGARAN, A) October 02, 2008, paragraphs [0070]-[0080]	4-9
Y	US 2011/0006956 A1 (MCCOWN, J) January 13, 2011, paragraphs [0032], [0040]-[0050]	4-9, 14
Y	US 7324057 B2 (ARGAMAN, G et al.) January 29, 2008, column 6, lines 23-26, lines 42-44	6-9
Y	US 2007/0001910 A1 (YAMANKA, K et al.) January 04, 2007, paragraphs [0165]- [0167])	10-12
Y	US 2010/0315307 A1 (SYED, J et al.) December 16, 2010, paragraphs [0022]-[0023]	15
<input type="checkbox"/> Further documents are listed in the continuation of Box C. <input type="checkbox"/>		
* Special categories of cited documents: "A" document defining the general state of the art which is not considered to be of particular relevance "E" earlier application or patent but published on or after the international filing date "L" document which may throw doubts on priority claim(s) or which is cited to establish the publication date of another citation or other special reason (as specified) "O" document referring to an oral disclosure, use, exhibition or other means "P" document published prior to the international filing date but later than the priority date claimed	"T" later document published after the international filing date or priority date and not in conflict with the application but cited to understand the principle or theory underlying the invention "X" document of particular relevance; the claimed invention cannot be considered novel or cannot be considered to involve an inventive step when the document is taken alone "Y" document of particular relevance; the claimed invention cannot be considered to involve an inventive step when the document is combined with one or more other such documents, such combination being obvious to a person skilled in the art "&" document member of the same patent family	
Date of the actual completion of the international search 16 June 2014 (16.06.2014)	Date of mailing of the international search report <div style="font-size: 2em; font-weight: bold; text-align: center;">01 JUL 2014</div>	
Name and mailing address of the ISA/US Mail Stop PCT, Attn: ISA/US, Commissioner for Patents P.O. Box 1450, Alexandria, Virginia 22313-1450 Facsimile No. 571-273-3201	Authorized officer: Shane Thomas PCT Helpdesk: 571-272-4300 PCT OSP: 571-272-7774	