



- (51) International Patent Classification:
A23G 3/00 (2006.01) A23G 3/02 (2006.01)
A23G 4/04 (2006.01)
- (21) International Application Number:
PCT/US2012/047409
- (22) International Filing Date:
19 July 2012 (19.07.2012)
- (25) Filing Language: English
- (26) Publication Language: English
- (30) Priority Data:
61/510,119 21 July 2011 (21.07.2011) US
- (71) Applicant (for all designated States except US): **KRAFT FOODS GLOBAL BRANDS LLC** [US/US]; Three Lakes Drive, Northfield, Illinois 60093 (US).
- (72) Inventors; and
- (75) Inventors/Applicants (for US only): **JANI, Bharat** [US/US]; 2 Montclair Court, Eask Brunswick, New Jersey 08816 (US). **SCAROLA, Leonard** [US/US]; 1214 Waterford Lake Drive, Cary, North Carolina 27519 (US). **VAN NIEKERK, Miles** [US/US]; 22 Green Avenue, Madison, New Jersey 07940 (US). **ADIVI, Krishna** [IN/US]; 18 Constantine Place, Apt. 28, Summit, New Jersey 07901 (US). **KIEFER, Jesse** [US/US]; 8 Lisa Court, Oxford, New Jersey 07863 (US).
- (74) Agent: **GIBSON, Daniel R.**; Cantor Colburn LLP, 20 Church Street, 22 Floor, Hartford, Connecticut 06103 (US).

(81) Designated States (unless otherwise indicated, for every kind of national protection available): AE, AG, AL, AM, AO, AT, AU, AZ, BA, BB, BG, BH, BR, BW, BY, BZ, CA, CH, CL, CN, CO, CR, CU, CZ, DE, DK, DM, DO, DZ, EC, EE, EG, ES, FI, GB, GD, GE, GH, GM, GT, HN, HR, HU, ID, IL, IN, IS, JP, KE, KG, KM, KN, KP, KR, KZ, LA, LC, LK, LR, LS, LT, LU, LY, MA, MD, ME, MG, MK, MN, MW, MX, MY, MZ, NA, NG, NI, NO, NZ, OM, PE, PG, PH, PL, PT, QA, RO, RS, RU, RW, SC, SD, SE, SG, SK, SL, SM, ST, SV, SY, TH, TJ, TM, TN, TR, TT, TZ, UA, UG, US, UZ, VC, VN, ZA, ZM, ZW.

(84) Designated States (unless otherwise indicated, for every kind of regional protection available): ARIPO (BW, GH, GM, KE, LR, LS, MW, MZ, NA, RW, SD, SL, SZ, TZ, UG, ZM, ZW), Eurasian (AM, AZ, BY, KG, KZ, RU, TJ, TM), European (AL, AT, BE, BG, CH, CY, CZ, DE, DK, EE, ES, FI, FR, GB, GR, HR, HU, IE, IS, IT, LT, LU, LV, MC, MK, MT, NL, NO, PL, PT, RO, RS, SE, SI, SK, SM, TR), OAPI (BF, BJ, CF, CG, CI, CM, GA, GN, GQ, GW, ML, MR, NE, SN, TD, TG).

Declarations under Rule 4.17:

- as to applicant's entitlement to apply for and be granted a patent (Rule 4.17(ii))
- as to the applicant's entitlement to claim the priority of the earlier application (Rule 4.17(iii))

Published:

- without international search report and to be republished upon receipt of that report (Rule 48.2(g))

(54) Title: ADVANCED GUM FORMING

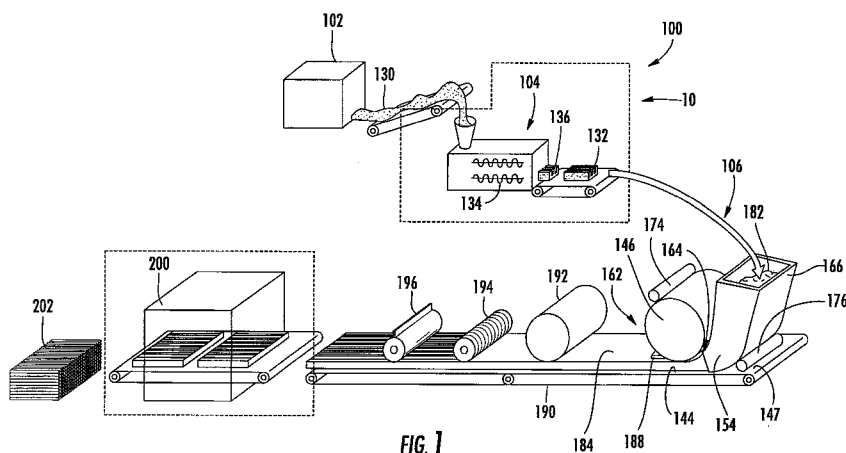

FIG. 1

(57) Abstract: Disclosed is a method of forming gum, the method including providing a pair of moving walls including a first wall and a second wall; and sizing a gum mass into a gum sheet having a substantially uniform thickness between about 0.3 mm to 10 mm using the pair of walls, the gum mass maintaining substantially continuous contact with at least one of the walls before and after the sizing.

WO 2013/013045 A2

ADVANCED GUM FORMING

FIELD OF THE INVENTION

[0001] The present invention relates to gum manufacturing methods and systems and more particularly relates to gum forming systems and methods.

BACKGROUND OF THE INVENTION

[0002] Typically, the process of making and packaging gum products is time-consuming and involves a significant amount of machinery. The process of making and packing gum products can include mixing and producing a finished gum as a non-uniform output, extruding and forming the finished gum into loaves, conditioning the loaves of the finished gum, extruding the loaves into a continuous thin sheet of the finished gum, rolling the continuous sheet through a series of rollers to a uniform reduced thickness, scoring and dividing sheets into individual scored sheets, conditioning the individual sheets in a conditioning room, dividing sheets into gum pieces, and packaging the gum pieces. Such processes of making and packaging gum products are disclosed in U.S. Patent No. 6,254,373 assigned to the predecessor of interest of the present assignee, and U.S. Patent Application No. 12/352,110 assigned to the present assignee; the teachings and disclosures of which are hereby incorporated by reference in their entireties to the extent not inconsistent with the present disclosure.

[0003] Traditional sizing machinery may include a sizing extruder that forces the chewing gum through a small rectangular orifice (e.g. a rectangular orifice having dimensions of about 25 mm by 457 mm). A relatively sizeable amount of force is required as the orifice size gets smaller (e.g. a 30 HP drive may be needed for sufficient output/production volume). Typically, the product exiting the sizing extruder is still much too thick. As a result, many prior systems will typically employ a series of sizing rollers arranged in sequence over a conveyor belt to progressively reduce the thickness of gum from around 25 mm to typically about 2-6 mm. To prevent sticking of gum to the rollers, dusting with a suitable powder agent is typically employed. Thereafter, a scoring roll and dividing roll may be used to generate thin sticks, or somewhat shorter and fatter slabs of gum, or pellets (any of the foregoing sticks, slabs, pellets or other dimension gum maybe referred to as "sized gum.") Such traditional lines also typically will necessitate a fair amount of subsequent cooling and/or conditioning prior to packaging as warm pliable product does not package well.

[0004] The present invention is directed toward improvements and advancements over such prior systems and methods of making and packaging gum products.

BRIEF SUMMARY OF THE INVENTION

[0005] Disclosed is a method of forming gum, the method including providing a pair of moving walls including a first wall and a second wall; and sizing a gum mass into a gum sheet having a substantially uniform thickness between about 0.3 mm to 10 mm using the pair of walls, the gum mass maintaining substantially continuous contact with at least one of the walls before and after the sizing.

[0006] Also disclosed is a method of forming gum, the method including providing a pair of moving walls including a first wall and a second wall, and sizing a gum mass into a gum sheet having a substantially uniform thickness between about 0.3 mm to 10 mm using the pair of walls, at least one of the walls including a substantially planar surface.

[0007] Additionally disclosed is a system of forming gum, the system including a gum inlet configured to provide a gum mass to the system; a pair of moving walls downstream of the inlet, the pair of moving walls including a first wall and a second wall, and a gap between the first and second walls, the gap being configured to size the gum mass into gum sheet including a width of substantially 0.3 mm to 10 mm, at least one of the walls being configured for substantially continuous and transporting contact with the gum sheet upstream and downstream of the gap.

[0008] Further disclosed is a system of forming gum, the system including a gum inlet configured to provide a gum mass to the system; a pair of moving walls downstream of the inlet, the pair of moving walls including a first wall and a second wall, and a gap between the first and second walls, the gap being configured to size the gum mass into a sheet including a width of substantially 0.3 mm to 10 mm, at least one of the walls including a substantially planar surface.

[0009] Still further disclosed is a method of forming gum, the method including providing a pair of moving walls including a first wall and a second wall, and sizing a gum mass into a gum sheet having a substantially uniform thickness between about 0.3 mm to 10 mm using the pair of walls, the gum mass being substantially unshaped immediately prior to the sizing.

[0010] Also disclosed is a system of forming gum, the system including a gum inlet configured to provide a gum mass to the system, a pair of moving walls downstream of the inlet, the pair of moving walls including a first wall and a second wall, and a gap between the

first and second walls, the gap being configured to size the gum mass into a gum sheet including a width of substantially 0.3 mm to 10 mm, the inlet being configured to provide the gum mass in a substantially unshaped form immediately upstream of the gap.

BRIEF DESCRIPTION OF THE DRAWINGS

- [0011] The accompanying drawings incorporated in and forming a part of the specification embodies several aspects of the present invention and, together with the description, serve to explain the principles of the invention. In the drawings:
- [0012] FIG. 1 is a partly schematic and partly perspective illustration of a gum manufacturing system according to a first embodiment;
- [0013] FIG. 2 is a partly schematic and partly perspective illustration of a gum manufacturing system according to a second embodiment;
- [0014] FIG. 3 is a partly schematic and partly perspective illustration of a gum manufacturing system according to a third embodiment;
- [0015] FIG. 4 is a partly schematic and partly perspective illustration of a gum manufacturing system according to a fourth embodiment;
- [0016] FIG. 5 is a schematic illustration of a cross-web view of the gum forming system including a set of rollers secured to structural frames, wherein a generally uniform cross web spacing is provided between the pair of rollers;
- [0017] FIG. 6 is a schematic illustration of a cross-web view of the gum forming system of FIG. 5 showing a deflection between the pair of rollers; and
- [0018] FIG. 7 is a perspective top view of a hopper including a pair of feed rollers according to an exemplary embodiment;
- [0019] FIG. 8 is a cross-sectional view of a pair of rollers including a cooling channel according to an exemplary embodiment;
- [0020] FIG. 9 is a perspective view of a stand-alone cooling roller according to an exemplary embodiment;
- [0021] FIG. 10 is a schematic illustration of a chilled conveyor belt according to an exemplary embodiment;
- [0022] FIG. 11 is a schematic illustration of a gum forming system including multiple heat transfer rollers according to an exemplary embodiment; and
- [0023] FIG. 12 is a schematic illustration of a gum forming walls according to an exemplary embodiment.

[0024] While the invention will be described in connection with certain preferred embodiments, there is no intent to limit it to those embodiments. On the contrary, the intent is to cover all alternatives, modifications and equivalents as included within the spirit and scope of the invention as defined by the appended claims.

DETAILED DESCRIPTION OF THE INVENTION

[0025] The following disclosure will detail particular embodiments according to the present disclosure, which provide improvements for forming a gum sheet and facilitating heat transfer from or to the gum sheet. In one embodiment, a system includes a set of moving walls for forming a gum structure/mass into a continuous web having a desired thickness and a width, while imparting temperature control to the gum at the same time. It should be noted that the term “walls” may be defined as any surface moveable within the system. The system can form the gum mass into a gum sheet including a desired width and thickness with a lower variance than conventional lines. Further, the system can eliminate a need of a sizing-type extruder and a series of rollers in conventional gum lines for progressively reducing a thickness of a gum mass to a desired sheet thickness. By eliminating the use of the sizing-type extruder, the system can operate at a much lower energy than the conventional lines including the sizing-type extruder. Therefore the system may reduce energy consumption and shear force introduced to the gum structure to preserve more shear or temperature sensitive ingredients in the gum.

[0026] Further, the system can produce a much wider width of the sheet of the gum when compared to the sizing-type extruder of conventional lines, and can also eliminate a need of powder dusting material. By eliminating the use of powder dusting material, a clean up time for change over can be reduced to a fraction of the conventional rolling and scoring lines, thereby significantly reducing a production down time. This additionally reduces overall cost of operating the line because there is no need for the additional dusting material. In addition to these advantages over the conventional lines, the moving walls of the system can also be chilled (or heated in some embodiments) to provide cooling during compression of the gum structure or mass into a gum sheet of a desirable thickness and width. Therefore, the system according to some embodiments can form and cool or heat the gum all at one step, thereby proving many advantages over conventional gum lines.

[0027] Further, gum products manufactured according to embodiments of the present disclosure can be structurally distinguishable from gum products produced using conventional gum lines, as the systems may result in different crystallization of gums by

quick cooling of the gum and eliminating a high shear sizing-type extruder, multiple rollers for rolling sizing reduction, and an extended cooling/conditioning of gums. Further, more aesthetically pleasing chewing gum production can occur by eliminating use of powder dusting materials and producing chewing gum products having a desired thickness and width with relatively small thickness and width variances when compared to those produced via conventional gum lines.

[0028] FIG. 1 shows a gum manufacturing system 100 according to an exemplary embodiment. The gum manufacturing system 100 generally includes a gum mixing system 102, a gum forming or sizing system 106, a scoring roller 194, and a dividing roller 196. The gum manufacturing system 100 is also shown here with an optional loafing machine 104, and a cooling tunnel 200. It should be noted that the scoring roller 194 and/or the dividing roller may also be disposed downstream of the cooling tunnel 200.

[0029] The gum mixing system 102 may include a single mixer or multiple mixers equipped with various mixer components and/or mixer feeding systems for processing gum ingredients to make a gum structure or mass. The mixers of mixing system 102 may be, for example, a batch mixer or a continuous mixer such as an extruder. Further, gum mixing system 102 could be, in some embodiments, merely a melting system that melts previously formed gum into a condition in which it can be subsequently formed.

[0030] In accordance with aspects of the system 106, the gum forming system 106 provides for sizing and potentially temperature control (i.e. cooling or heating), and reduces/eliminates downstream progressive rolling operations. This gum forming system 106 also, as will be explained, can be used to eliminate sizing type extruders (e.g. the extruders that form wide thin ribbons of gum), which may reduce a processing force or average strain, and temperature, thereby leading to less attrition of pressure sensitive materials. The system may also increase the amount of shear or temperature sensitive ingredients remaining intact during processing. The gum forming system 106 may be used to form various gum masses (of various compositions), such as a finished gum, a finished gum base, a gum base including candy bits, etc. Although, most of the embodiments discussed herein involve gum, other confectioneries that do not contain an elastomeric compound can also be formed, sized and/or conditioned using the forming station 106. Before turning to greater details of the gum mixing system 102, first some general compositional information about gum will be provided.

[0031] CHEWING GUM GENERALLY

[0032] Chewing gum comprises in large part of components that are usually never swallowed, gum base, which is the rubber-like chewing component. Chewing gum also comprises a consumed portion including sweeteners, flavors and the like, and may also include other candy or food product integrated therewith in layers or as ingredients. The gum base is relatively unique in food processing in that it introduces the material with a resiliency and elasticity and also provides a relatively non-conductive or insulating material that does not transfer heat very well. This provides unique processing difficulties. Relative to processing, the temperature of the processed gum product greatly affects viscosity as well as other processing characteristics such as elasticity and resiliency.

[0033] Further, different types of gum recipes will also alter processing considerations, and there generally is a desire to run different gum recipes on the same equipment or lines. Some of the ingredients handle processing quite well. Other ingredients such as flavors may be subject to flash off due to heat, thereby diminishing the amount of flavor in the final consumable product. Other ingredients such as encapsulated sweeteners, are sensitive to shear forces (e.g. due to substantial pressure, intense mixing, processing force and the like) and thus can be damaged during processing. These factors all provide different challenges relative to sizing the gum to a small bit size portion and conditioning of the gum for packaging in gum packaging. For purpose of understanding, some lexicography and typical gum composition components will be discussed below.

[0034] As used herein, "gum structure," "gum mass," or "gum sheets" may include, but are not limited to, compositions ranging from and inclusive of compounded elastomer to finished gum, which may include compounded elastomer in addition to some compounding aids, master batch gum base, compounded elastomer in addition to some subsequent gum ingredients, compounded elastomer in addition to some gum base ingredients and some subsequent gum ingredients, gum base, gum base in addition to some subsequent gum ingredients, master batch finished gum, and finished gum.

[0035] Before explaining systems and methods according to the present invention, it is helpful to discuss the general composition of several typical gum structures that are or may be included in forming the most complex gum structure, namely finished gum, that can be formed using embodiments of the systems and methods of the present invention.

[0036] A "finished gum", as used herein, will refer to a gum structure that is generally ready for preparation to distribute the product to the consumer. As such, a finished gum may still require temperature conditioning, forming, shaping, packaging and coating. However, the gum composition itself is generally finished. Not all finished gums have the same

ingredients or the same amounts of individual ingredients. By varying the ingredients and amounts of ingredients, textures, flavor and sensations, among other things, can be varied to provide differing characteristics to meet the needs of users.

[0037] As is generally well known, a finished gum generally includes a water soluble bulk portion, a water insoluble gum base portion, and one or more flavoring agents. The water soluble portion dissipates over a period of time during chewing. The gum base portion is retained in the mouth throughout the chewing process. A finished gum is typically ready for user consumption.

[0038] A "finished gum base", as used herein, will refer to a gum structure that includes a sufficient combination of gum base ingredients that need only be combined with subsequent gum ingredients to form a finished gum. A finished gum base is a chewable visco-elastic material that includes at least a viscous component, an elastic component, and a softener component. For example, a typical gum base may include elastomer, at least some of the filler, resin and/or plasticizer, polyvinyl acetate, and a softener (such as an oil, fat or wax). Merely compounded elastomer without the addition of any softener, for example, would not be a finished gum base because it would not be considered useable in a finished gum structure because of its difficulty, if not impossibility, to chew.

[0039] Ingredients

[0040] Gum structures may include a vast number of ingredients in various categories. Gum mixing systems and methods according to various embodiments of the present invention may be used to mix any and all known ingredients including, but not limited to, ingredients in the following ingredient categories: elastomers, bulking agents, elastomer plasticizers (which includes resins), elastomer solvents, plasticizers, fats, waxes, fillers, antioxidants, sweeteners (e.g. bulk sweeteners and high intensity sweeteners), syrups/fluids, flavors, sensates, potentiators, acids, emulsifiers, colors, and functional ingredients.

[0041] The insoluble gum base generally includes ingredients falling under the following categories: elastomers, elastomer plasticizers (resins or solvents), plasticizers, fats, oils, waxes, softeners and fillers. Further discussion of representative ingredients within each category will be provided later on. The gum base may constitute between 5-95% by weight of a finished gum, more typically 10-50% by weight of the finished gum, and most commonly 20-30% by weight of the finished gum.

[0042] The water soluble portion of finished gum may include subsequent gum ingredients falling under the following categories: softeners, bulk sweeteners, high intensity sweeteners, flavoring agents, acids, additional fillers, functional ingredients and combinations

thereof. Softeners are added to the gum in order to optimize the chewability and mouth feel of the gum. The softeners, which are also known as plasticizers, plasticizing agents or emulsifiers, generally constitute between about 0.5-15% by weight of the gum structure. Bulk sweeteners constitute between 5-95% by weight of the gum structure, more typically 20-80% by weight of the gum and most commonly 30-60% by weight of the gum. High intensity sweeteners may also be present and are commonly used with sugarless sweeteners. When used, high intensity sweeteners typically constitute between 0.001-5% by weight of the gum structure, preferably between 0.01-3% by weight of the chewing gum. Typically, high intensity sweeteners are at least 20 times sweeter than sucrose.

[0043] Flavor should generally be present in the gum in an amount within the range of about 0.1-15% by weight of the chewing gum, preferably between about 0.2-5% by weight of the gum, most preferably between about 0.5-3% by weight of the gum. Natural and artificial flavoring agents may be used and combined in any sensorially acceptable fashion.

[0044] When included, acids typically constitute between about 0.001-5% by weight of the gum structure.

[0045] Optional ingredients such as colors, functional ingredients and additional flavoring agents may also be included in gum structures.

[0046] Now that a more general overview has been provided as to general common ingredients, more details about individual categories of ingredients and examples of specific ingredients within various categories will be provided below.

[0047] Elastomers

[0048] The elastomers (rubbers) employed in the gum structure will vary greatly depending upon various factors such as the type of gum structure desired, the consistency of gum structure desired and the other components used in the gum structure. The elastomer may be any water-insoluble polymer known in the art, and includes those polymers utilized for chewing gums and bubble gums. Illustrative examples of suitable polymers in gum structures, and particularly gum bases, include both natural and synthetic elastomers. For example, those polymers which are suitable in gum structures include, without limitation, natural substances (of vegetable origin) such as caspi, chicle, natural rubber, crown gum, nispero, rosidinha, jelutong, guayule, perillo, niger gutta, tunu, balata, guttapercha, lechi capsi, sorva, gutta kay, and the like, and combinations thereof. Examples of synthetic elastomers include, without limitation, styrene-butadiene copolymers (SBR), polyisobutylene, isobutylene-isoprene copolymers, polyethylene, polyvinyl acetate and the

like, and combinations thereof. Elastomers constitute between about 10% to about 60% by weight and more commonly between about 35-40% by weight of the gum structure.

[0049] Additional useful polymers include: crosslinked polyvinyl pyrrolidone, polymethylmethacrylate; copolymers of lactic acid, polyhydroxyalkanoates, plasticized ethylcellulose, polyvinyl acetatephthalate and combinations thereof.

[0050] Elastomer Plasticizers

[0051] The gum structure may contain elastomer solvents, also referred to herein as elastomer plasticizers, to aid in softening the elastomeric materials. Such elastomer solvents may include those elastomer solvents known in the art, for example, terpinene resins such as polymers of alpha-pinene, beta-pinene or d-limonene, methyl, glycerol and pentaerythritol esters of rosins and modified rosins and gums such as hydrogenated, dimerized and polymerized rosins, and mixtures thereof. Examples of elastomer solvents suitable for use herein may include the pentaerythritol ester of partially hydrogenated wood and gum rosin, the pentaerythritol ester of wood and gum rosin, the glycerol ester of wood rosin, the glycerol ester of partially dimerized wood and gum rosin, the glycerol ester of polymerized wood and gum rosin, the glycerol ester of tall oil rosin, the glycerol ester of wood and gum rosin and the partially hydrogenated wood and gum rosin and the partially hydrogenated methyl ester of wood and rosin, and the like, and mixtures thereof. The elastomer solvent may be employed in the gum structure in amounts from about 2% to about 15%, and preferably from about 7% to about 11%, by weight of the gum structure.

[0052] Plasticizers

[0053] The gum structure may also include plasticizers or softeners, which also fall under the Wax category described below, to provide a variety of desirable textures and consistency properties. Because of the low molecular weight of these ingredients, the plasticizers and softeners are able to penetrate the fundamental structure of the gum structure making it plastic and less viscous. Useful plasticizers and softeners include triacetin, medium chain triglycerides of non-hydrogenated, partially hydrogenated cotton seed oil, soybean oil, palm oil, palm kernel oil, coconut oil, safflower oil, tallow oil, cocoa butter, terpenene resins derived from alpha-pinene, lanolin, palmitic acid, oleic acid, stearic acid, sodium stearate, potassium stearate, glyceryl triacetate, glyceryl lecithin, glyceryl monostearate, propylene glycol monostearate, acetylated monoglyceride, glycerine, and the like, and mixtures thereof. Waxes, for example, natural and synthetic waxes, hydrogenated vegetable oils, petroleum waxes such as polyurethane waxes, polyethylene waxes, paraffin waxes, sorbitan monostearate, tallow, propylene glycol, mixtures thereof, and the like, may also be

incorporated into the gum structure. The plasticizers and softeners are generally employed in the gum structure in amounts up to about 20% by weight of the gum structure, and more specifically in amounts from about 9% to about 17%, by weight of the gum structure.

[0054] Plasticizers may also include hydrogenated vegetable oils, soybean oil and cottonseed oil which may be employed alone or in combination. These plasticizers provide the gum structure with good texture and soft chew characteristics. These plasticizers and softeners are generally employed in amounts from about 5% to about 14%, and more specifically in amounts from about 5% to about 13.5%, by weight of the gum structure.

[0055] Fats

[0056] Suitable oils and fats include partially hydrogenated vegetable or animal fats, such as coconut oil, palm kernel oil, beef tallow, and lard, among others. These ingredients when used are generally present in amounts up to about 7%, and preferably up to about 3.5%, by weight of the gum structure.

[0057] Waxes

[0058] In some embodiments, the gum structure may include wax. Waxes that are used may include synthetic waxes such as waxes containing branched alkanes and copolymerized with monomers such as, but not limited to, polypropylene and polyethylene and Fischer-Tropsch type waxes, petroleum waxes such as paraffin, and microcrystalline wax, and natural waxes such as beeswax, candellia, carnauba, and polyethylene wax, rice bran and petroleum.

[0059] It softens the polymeric mixture and improves the elasticity of the gum structure. When present, the waxes employed will have a melting point below about 60°C, and preferably between about 45°C and about 55°C. The low melting wax may be a paraffin wax. The wax may be present in the gum structure in an amount from about 6% to about 10%, and preferably from about 7% to about 9.5%, by weight of the gum structure.

[0060] In addition to the low melting point waxes, waxes having a higher melting point may be used in the gum structure in amounts up to about 5%, by weight of the gum structure. Such high melting waxes include beeswax, vegetable wax, candelilla wax, carnuba wax, most petroleum waxes, and the like, and mixtures thereof.

[0061] Fillers

[0062] In some embodiments, gum structures formed using the systems and methods according to the teachings of the invention may also include effective amounts of bulking agents such as mineral adjuvants which may serve as fillers and textural agents. Useful mineral adjuvants include calcium carbonate, magnesium carbonate, alumina, aluminum hydroxide, aluminum silicate, talc, clay, titanium oxide, ground limestone, monocalcium

phosphate, tricalcium phosphate, dicalcium phosphate, calcium sulfate and the like, and mixtures thereof. These fillers or adjuvants may be used in the gum structure in various amounts. The amount of filler, may be present in an amount from about zero to about 40%, and more specifically from about zero to about 30%, by weight of the gum structure. In some embodiments, the amount of filler will be from about zero to about 15%, more specifically from about 3% to about 11%.

[0063] Antioxidants

[0064] Antioxidants can include materials that scavenge free radicals. In some embodiments, antioxidants can include but are not limited to ascorbic acid, citric acid (citric acid may be encapsulated), rosemary oil, vitamin A, vitamin E, vitamin E phosphate, butylated hydroxytoluene (BHT), butylated hydroxyanisole (BHA), propyl gallate, tocopherols, di-alpha-tocopheryl phosphate, tocotrienols, alpha lipoic acid, dihydrolipoic acid, xanthophylls, beta cryptoxanthin, lycopene, lutein, zeaxanthin, astaxanthin, beta-carotene, carotenes, mixed carotenoids, polyphenols, flavonoids, and combinations thereof.

[0065] Subsequent Ingredients

[0066] The gum structure may also include amounts of conventional additives selected from the group consisting of sweetening agents (bulk and high intensity sweeteners), softeners, emulsifiers, fillers, bulking agents (carriers, extenders, bulk sweeteners), flavoring agents (flavors, flavorings), coloring agents (colorants, colorings), functional ingredients, and the like, and mixtures thereof. Some of these additives may serve more than one purpose. For example, in sugarless gum structure, a sweetener, such as maltitol or other sugar alcohol, may also function as a bulking agent and particularly a water soluble bulking agent.

[0067] Bulk Sweeteners

[0068] Suitable Bulk Sweeteners include monosaccharides, disaccharides and polysaccharides such as xylose, ribulose, glucose (dextrose), lactose, mannose, galactose, fructose (levulose), sucrose (sugar), maltose, invert sugar, partially hydrolyzed starch and corn syrup solids, sugar alcohols, randomly bonded glucose polymers such as those polymers distributed under the tradename Litesse™ which is the brand name for polydextrose and is manufactured by Danisco Sweeteners, Ltd. of 41-51 Brighton Road, Redhill, Surrey, RH1 6YS, United Kingdom; isomalt (a racemic mixture of alpha-D-glucopyranosyl-1,6-mannitol and alpha-D-glucopyranosyl-1,6-sorbitol manufactured under the tradename PALATINIT™ by Palatinit Sussungsmittel GmbH of Gotlieb-Daimler-Strause 12 a, 68165 Mannheim, Germany); maltodextrins; hydrogenated starch hydrolysates; hydrogenated hexoses;

hydrogenated disaccharides; minerals, such as calcium carbonate, talc, titanium dioxide, dicalcium phosphate; celluloses; and mixtures thereof.

[0069] Suitable sugarless bulk sweeteners include sorbitol, xylitol, mannitol, galactitol, lactitol, maltitol, erythritol, isomalt and mixtures thereof. Suitable hydrogenated starch hydrolysates include those disclosed in U.S. Pat. No. 4,279,931 and various hydrogenated glucose syrups and/or powders which contain sorbitol, maltitol, hydrogenated disaccharides, hydrogenated higher polysaccharides, or mixtures thereof. Hydrogenated starch hydrolysates are primarily prepared by the controlled catalytic hydrogenation of corn syrups. The resulting hydrogenated starch hydrolysates are mixtures of monomeric, dimeric, and polymeric saccharides. The ratios of these different saccharides give different hydrogenated starch hydrolysates different properties. Mixtures of hydrogenated starch hydrolysates, such as LYCASIN®, a commercially available product manufactured by Roquette Freres of France, and HYSTAR®, a commercially available product manufactured by SPI Polyols, Inc. of New Castle, Delaware, are also useful.

[0070] In some embodiments, the gum structure may include a specific polyol composition including at least one polyol which is from about 30% to about 80% by weight of said gum structure, and specifically from 50% to about 60%. In some embodiments, such gum structures may have low hygroscopicity. The polyol composition may include any polyol known in the art including, but not limited to maltitol, sorbitol, erythritol, xylitol, mannitol, isomalt, lactitol and combinations thereof. Lycasin™ which is a hydrogenated starch hydrolysate including sorbitol and maltitol, may also be used.

[0071] The amount of the polyol composition or combination of polyols used in the gum structure will depend on many factors including the type of elastomers used in the gum structure and the particular polyols used. For example, wherein the total amount of the polyol composition is in the range of about 40% to about 65% based on the weight of the gum structure, the amount of isomalt may be from about 40% to about 60% in addition to an amount of sorbitol from about 0 up to about 10%, more specifically, an amount of isomalt may be from about 45% to about 55% in combination with sorbitol from about 5% to about 10% based on the weight of the gum structure.

[0072] The polyol composition which may include one or more different polyols which may be derived from a genetically modified organism (“GMO”) or GMO free source. For example, the maltitol may be GMO free maltitol or provided by a hydrogenated starch hydrolysate. For the purposes of this invention, the term “GMO-free” refers to a composition that has been derived from process in which genetically modified organisms are not utilized.

[0073] The sweetening agents which may be included in some gum structures formed using systems and methods according to the teachings of the present invention may be any of a variety of sweeteners known in the art and may be used in many distinct physical forms well-known in the art to provide an initial burst of sweetness and/or a prolonged sensation of sweetness. Without being limited thereto, such physical forms include free forms, such as spray dried, powdered, beaded forms, encapsulated forms, and mixtures thereof.

[0074] High Intensity Sweeteners

[0075] Desirably, the sweetener is a high intensity sweetener such as aspartame, neotame, sucralose, monatin, and acesulfame potassium (Ace-K). The high intensity sweetener can be in an encapsulated form, a free form, or both.

[0076] In general, an effective amount of sweetener may be utilized to provide the level of sweetness desired, and this amount may vary with the sweetener selected. In some embodiments the amount of sweetener may be present in amounts from about 0.001% to about 3%, by weight of the gum, depending upon the sweetener or combination of sweeteners used. The exact range of amounts for each type of sweetener may be selected by those skilled in the art.

[0077] The sweeteners involved may be selected from a wide range of materials including water-soluble sweeteners, water-soluble artificial sweeteners, water-soluble sweeteners derived from naturally occurring water-soluble sweeteners, dipeptide based sweeteners, and protein based sweeteners, including mixtures thereof. Without being limited to particular sweeteners, representative categories and examples include:

[0078] (a) water-soluble sweetening agents such as dihydrochalcones, monellin, steviosides, lo han quo, lo han quo derivatives, glycyrrhizin, dihydroflavenol, and sugar alcohols such as sorbitol, mannitol, maltitol, xylitol, erythritol, and L-aminodicarboxylic acid aminoalkenoic acid ester amides, such as those disclosed in U.S. Pat. No. 4,619,834, which disclosure is incorporated herein by reference, and mixtures thereof;

[0079] (b) water-soluble artificial sweeteners such as soluble saccharin salts, i.e., sodium or calcium saccharin salts, cyclamate salts, the sodium, ammonium or calcium salt of 3,4-dihydro-6-methyl-1,2,3-oxathiazine-4-one-2,2-dioxide, the potassium salt of 3,4-dihydro-6-methyl-1,2,3-oxathiazine-4-one-2,2-dioxide (Acesulfame-K), the free acid form of saccharin, and mixtures thereof;

[0080] (c) dipeptide based sweeteners, such as L-aspartic acid derived sweeteners, such as L-aspartyl-L-phenylalanine methyl ester (Aspartame), N-[N-(3,3-dimethylbutyl)-L- α -aspartyl]-L-phenylalanine 1-methyl ester (Neotame), and materials described in U.S. Pat.

No. 3,492,131, L-alphaaspartyl-N-(2,2,4,4-tetramethyl-3-thietanyl)-D-alaninamide hydrate (Alitame), methyl esters of L-aspartyl-L-phenylglycerine and L-aspartyl-L-2,5-dihydrophenyl-glycine, L-aspartyl-2,5-dihydro-L-phenylalanine; L-aspartyl-L-(1-cyclohexen)-alanine, and mixtures thereof;

[0081] (d) water-soluble sweeteners derived from naturally occurring water-soluble sweeteners, such as chlorinated derivatives of ordinary sugar (sucrose), e.g., chlorodeoxysugar derivatives such as derivatives of chlorodeoxysucrose or chlorodeoxygalactosucrose, known, for example, under the product designation of Sucralose; examples of chlorodeoxysucrose and chlorodeoxygalactosucrose derivatives include but are not limited to: 1-chloro-1'-deoxysucrose; 4-chloro-4-deoxy-alpha-D-galactopyranosyl-alpha-D-fructofuranoside, or 4-chloro-4-deoxygalactosucrose; 4-chloro-4-deoxy-alpha-D-galactopyranosyl-1-chloro-1-deoxy-beta-D-fructofuranoside, or 4,1'-dichloro-4,1'-dideoxygalactosucrose; 1',6'-dichloro-1',6'-dideoxysucrose; 4-chloro-4-deoxy-alpha-D-galactopyranosyl-1,6-dichloro-1,6-dideoxy-beta-D-fructofuranoside, or 4,1',6'-trichloro-4,1',6'-trideoxygalactosucrose; 4,6-dichloro-4,6-dideoxy-alpha-D-galactopyranosyl-6-chloro-6-deoxy-beta-D-fructofuranoside, or 4,6,6'-trichloro-4,6,6'-trideoxygalactosucrose; 6,1',6'-trichloro-6,1',6'-trideoxysucrose; 4,6-dichloro-4,6-dideoxy-alpha-D-galactopyranosyl-1,6-dichloro-1,6-dideoxy-beta-D-fructofuranoside, or 4,6,1',6'-tetrachloro-4,6,1',6'-tetradeoxygalactosucrose; and 4,6,1',6'-tetradeoxy-sucrose, and mixtures thereof;

[0082] (e) protein based sweeteners such as thaumococcus danielli (Thaumatococcus daniellii) (Thaumatococin I and II) and talin; and

[0083] (f) the sweetener monatin (2-hydroxy-2-(indol-3-ylmethyl)-4-aminoglutaric acid) and its derivatives.

[0084] The intense sweetening agents may be used in many distinct physical forms well-known in the art to provide an initial burst of sweetness and/or a prolonged sensation of sweetness. Without being limited thereto, such physical forms include free forms, spray dried forms, powdered forms, beaded forms, encapsulated forms, and mixtures thereof. In one embodiment, the sweetener is a high intensity sweetener such as aspartame, sucralose, and acesulfame potassium (e.g., Ace-K or acesulfame-K). Several representative forms of encapsulated sweeteners and methods of encapsulating sweeteners are illustrated in U.S. Patent Nos. 7,244,454; 7,022,352; 6,759,066; 5,217,735 ;5,192,561; 5,164,210; 4,997,659 and 4,981,698 as well as U.S. Patent Application Publication Nos. 2007/0231424; 2004/0096544; 2005/0112236; and 2005/0220867, the teachings and disclosure of which are hereby incorporated in their entireties by reference thereto.

[0085] The active component (e.g., sweetener), which is part of the delivery system, may be used in amounts necessary to impart the desired effect associated with use of the active component (e.g., sweetness). In general, an effective amount of intense sweetener may be utilized to provide the level of sweetness desired, and this amount may vary with the sweetener selected. The intense sweetener may be present in amounts from about 0.001% to about 3%, by weight of the composition, depending upon the sweetener or combination of sweeteners used. The exact range of amounts for each type of sweetener may be selected by those skilled in the art.

[0086] Syrups

[0087] Anhydrous glycerin may also be employed as a softening agent, such as the commercially available United States Pharmacopeia (USP) grade. Glycerin is a syrupy liquid with a sweet warm taste and has a sweetness of about 60% of that of cane sugar. Because glycerin is hygroscopic, the anhydrous glycerin may be maintained under anhydrous conditions throughout the preparation of the gum structure. Other syrups may include corn syrup and maltitol syrup.

[0088] Flavorants

[0089] In some embodiments, flavorants may include those flavors known to the skilled artisan, such as natural and artificial flavors. These flavorings may be chosen from synthetic flavor oils and flavoring aromatics and/or oils, oleoresins and extracts derived from plants, leaves, flowers, fruits, and so forth, and combinations thereof. Nonlimiting representative flavor oils include spearmint oil, cinnamon oil, oil of wintergreen (methyl salicylate), peppermint oil, Japanese mint oil, clove oil, bay oil, anise oil, eucalyptus oil, thyme oil, cedar leaf oil, oil of nutmeg, allspice, oil of sage, mace, oil of bitter almonds, and cassia oil. Also useful flavorings are artificial, natural and synthetic fruit flavors such as vanilla, and citrus oils including lemon, orange, lime, grapefruit, yuzu, sudachi, and fruit essences including apple, pear, peach, grape, blueberry, strawberry, raspberry, cherry, plum, pineapple, apricot, banana, melon, apricot, ume, cherry, raspberry, blackberry, tropical fruit, mango, mangosteen, pomegranate, papaya and so forth. Other potential flavors whose release profiles can be managed include a milk flavor, a butter flavor, a cheese flavor, a cream flavor, and a yogurt flavor; a vanilla flavor; tea or coffee flavors, such as a green tea flavor, a oolong tea flavor, a tea flavor, a cocoa flavor, a chocolate flavor, and a coffee flavor; mint flavors, such as a peppermint flavor, a spearmint flavor, and a Japanese mint flavor; spicy flavors, such as an asafetida flavor, an ajowan flavor, an anise flavor, an angelica flavor, a fennel flavor, an allspice flavor, a cinnamon flavor, a camomile flavor, a mustard flavor, a

cardamom flavor, a caraway flavor, a cumin flavor, a clove flavor, a pepper flavor, a coriander flavor, a saffron flavor, a savory flavor, a Zanthoxyli Fructus flavor, a perilla flavor, a juniper berry flavor, a ginger flavor, a star anise flavor, a horseradish flavor, a thyme flavor, a tarragon flavor, a dill flavor, a capsicum flavor, a nutmeg flavor, a basil flavor, a marjoram flavor, a rosemary flavor, a bayleaf flavor, and a wasabi (Japanese horseradish) flavor; alcoholic flavors, such as a wine flavor, a whisky flavor, a brandy flavor, a rum flavor, a gin flavor, and a liqueur flavor; floral flavors; and vegetable flavors, such as an onion flavor, a garlic flavor, a cabbage flavor, a carrot flavor, a celery flavor, mushroom flavor, and a tomato flavor. These flavoring agents may be used in liquid or solid form and may be used individually or in admixture. Commonly used flavors include mints such as peppermint, menthol, spearmint, artificial vanilla, cinnamon derivatives, and various fruit flavors, whether employed individually or in admixture. Flavors may also provide breath freshening properties, particularly the mint flavors when used in combination with the cooling agents, described herein below. In some embodiments, flavorants may be chosen from geraniol, linalool, nerol, nerolidol, citronellol, heliotropine, methyl cyclopentelone, ethyl vanillin, maltol, ethyl maltol, furaneol, alliaceous compounds, rose type compounds such as phenethanol, phenylacetic acid, nerol, linalyl esters, jasmine, sandalwood, patchouli, and/or cedarwood.

[0090] In some embodiments, other flavorings include aldehydes and esters such as cinnamyl acetate, cinnamaldehyde, citral diethylacetal, dihydrocarvyl acetate, eugenyl formate, p methylamisol, and so forth may be used. Generally any flavoring or food additive such as those described in *Chemicals Used in Food Processing*, publication 1274, pages 63-258, by the National Academy of Sciences, may be used. This publication is incorporated herein by reference. These may include natural as well as synthetic flavors.

[0091] Further examples of aldehyde flavorings include but are not limited to acetaldehyde (apple), benzaldehyde (cherry, almond), anisic aldehyde (licorice, anise), cinnamic aldehyde (cinnamon), citral, i.e., alpha citral (lemon, lime), nerol, i.e., beta citral (lemon, lime), decanal (orange, lemon), ethyl vanillin (vanilla, cream), heliotrope, i.e., piperonal (vanilla, cream), vanillin (vanilla, cream), alpha amyl cinnamaldehyde (spicy fruity flavors), butyraldehyde (butter, cheese), valeraldehyde (butter, cheese), citronellal (modifies, many types), decanal (citrus fruits), aldehyde C 8 (citrus fruits), aldehyde C 9 (citrus fruits), aldehyde C 12 (citrus fruits), 2 ethyl butyraldehyde (berry fruits), hexenal, i.e., trans 2 (berry fruits), tolyl aldehyde (cherry, almond), veratraldehyde (vanilla), 2,6 dimethyl 5 heptenal, i.e., melonal (melon), 2,6 dimethyloctanal (green fruit), and 2 dodecenal (citrus, mandarin), cherry, grape, blueberry, blackberry, strawberry shortcake, and mixtures thereof.

[0092] In some embodiments, flavoring agents are used at levels that provide a perceptible sensory experience i.e. at or above their threshold levels. In other embodiments, flavoring agents are used at levels below their threshold levels such that they do not provide an independent perceptible sensory experience. At subthreshold levels, the flavoring agents may provide an ancillary benefit such as flavor enhancement or potentiation.

[0093] In some embodiments, a flavoring agent may be employed in either liquid form and/or dried form. When employed in the latter form, suitable drying means such as spray drying the liquid may be used. Alternatively, the flavoring agent may be absorbed onto water soluble materials, such as cellulose, starch, sugar, maltodextrin, gum arabic and so forth or may be encapsulated. In still other embodiments, the flavoring agent may be adsorbed onto silicas, zeolites, and the like.

[0094] In some embodiments, the flavoring agents may be used in many distinct physical forms. Without being limited thereto, such physical forms include free forms, such as spray dried, powdered, beaded forms, encapsulated forms, and mixtures thereof.

[0095] Illustrations of the encapsulation of flavors as well as other additional components can be found in the examples provided herein. Typically, encapsulation of a component will result in a delay in the release of the predominant amount of the component during consumption of a gum structure that includes the encapsulated component (e.g., as part of a delivery system added as an ingredient to the gum structure). In some embodiments, the release profile of the ingredient (e.g., the flavor, sweetener, etc.) can be managed by managing various characteristics of the ingredient, delivery system containing the ingredient, and/or the gum structure containing the delivery system and/or how the delivery system is made. For example, characteristics might include one or more of the following: tensile strength of the delivery system, water solubility of the ingredient, water solubility of the encapsulating material, water solubility of the delivery system, ratio of ingredient to encapsulating material in the delivery system, average or maximum particle size of ingredient, average or maximum particle size of ground delivery system, the amount of the ingredient or the delivery system in the gum structure, ratio of different polymers used to encapsulate one or more ingredients, hydrophobicity of one or more polymers used to encapsulate one or more ingredients, hydrophobicity of the delivery system, the type or amount of coating on the delivery system, the type or amount of coating on an ingredient prior to the ingredient being encapsulated, etc.

[0096] Sensate Ingredients

[0097] Sensate compounds can include cooling agents, warming agents, tingling agents, effervescent agents, and combinations thereof. A variety of well known cooling agents may be employed. For example, among the useful cooling agents are included xylitol, erythritol, dextrose, sorbitol, menthane, menthone, ketals, menthone ketals, menthone glycerol ketals, substituted p menthanes, acyclic carboxamides, mono menthyl glutarate, substituted cyclohexanamides, substituted cyclohexane carboxamides, substituted ureas and sulfonamides, substituted menthanols, hydroxymethyl and hydroxymethyl derivatives of p menthane, 2 mercapto cyclo decanone, hydroxycarboxylic acids with 2 6 carbon atoms, cyclohexanamides, menthyl acetate, menthyl salicylate, N,2,3 trimethyl 2 isopropyl butanamide (WS 23), N ethyl p menthane 3 carboxamide (WS 3), isopulegol, 3-(1-menthoxy)propane-1,2-diol, 3-(1-menthoxy)-2-methylpropane-1,2-diol, p-menthane-2,3-diol, p-menthane-3,8-diol, 6-isopropyl-9-methyl-1,4-dioxaspiro[4,5]decane-2-methanol, menthyl succinate and its alkaline earth metal salts, trimethylcyclohexanol, N-ethyl-2-isopropyl-5-methylcyclohexanecarboxamide, Japanese mint oil, peppermint oil, 3-(1-menthoxy)ethan-1-ol, 3-(1-menthoxy)propan-1-ol, 3-(1-menthoxy)butan-1-ol, 1-menthylacetic acid N-ethylamide, 1-menthyl-4-hydroxypentanoate, 1-menthyl-3-hydroxybutyrate, N,2,3-trimethyl-2-(1-methylethyl)-butanamide, n-ethyl-t-2-c-6 nonadienamamide, N,N-dimethyl menthyl succinamide, substituted p-menthanes, substituted p-menthane-carboxamides, 2-isopropanyl-5-methylcyclohexanol (from Hisamitsu Pharmaceuticals, hereinafter "isopregol"); menthone glycerol ketals (FEMA 3807, tradename FRESCOLAT® type MGA); 3-1-menthoxypropane-1,2-diol (from Takasago, FEMA 3784); and menthyl lactate; (from Haarman & Reimer, FEMA 3748, tradename FRESCOLAT® type ML), WS-30, WS-14, Eucalyptus extract (p-Mehtha-3,8-Diol), Menthol (its natural or synthetic derivatives), Menthol PG carbonate, Menthol EG carbonate, Menthol glyceryl ether, N-tertbutyl-p-menthane-3-carboxamide, P-menthane-3-carboxylic acid glycerol ester, Methyl-2-isopryl-bicyclo (2.2.1), Heptane-2-carboxamide; and Menthol methyl ether, and menthyl pyrrolidone carboxylate among others. These and other suitable cooling agents are further described in the following U.S. patents, all of which are incorporated in their entirety by reference hereto: U.S. 4,230,688; 4,032,661; 4,459,425; 4,136,163; 5,266,592; 6,627,233.

[0098] In some embodiments, warming components may be selected from a wide variety of compounds known to provide the sensory signal of warming to the user. These compounds offer the perceived sensation of warmth, particularly in the oral cavity, and often enhance the perception of flavors, sweeteners and other organoleptic components. In some embodiments, useful warming compounds can include vanillyl alcohol n butylether (TK

1000) supplied by Takasago Perfumary Company Limited, Tokyo, Japan, vanillyl alcohol n propylether, vanillyl alcohol isopropylether, vanillyl alcohol isobutylether, vanillyl alcohol n aminoether, vanillyl alcohol isoamylether, vanillyl alcohol n hexylether, vanillyl alcohol methylether, vanillyl alcohol ethylether, gingerol, shogaol, paradol, zingerone, capsaicin, dihydrocapsaicin, nordihydrocapsaicin, homocapsaicin, homodihydrocapsaicin, ethanol, isopropyl alcohol, iso amylalcohol, benzyl alcohol, glycerine, and combinations thereof.

[0099] In some embodiments, a tingling sensation can be provided. One such tingling sensation is provided by adding jambu, oleoresin, or spilanthol to some examples. In some embodiments, alkylamides extracted from materials such as jambu or sanshool can be included. Additionally, in some embodiments, a sensation is created due to effervescence. Such effervescence is created by combining an alkaline material with an acidic material. In some embodiments, an alkaline material can include alkali metal carbonates, alkali metal bicarbonates, alkaline earth metal carbonates, alkaline earth metal bicarbonates and mixtures thereof. In some embodiments, an acidic material can include acetic acid, adipic acid, ascorbic acid, butyric acid, citric acid, formic acid, fumaric acid, glyconic acid, lactic acid, phosphoric acid, malic acid, oxalic acid, succinic acid, tartaric acid and combinations thereof. Examples of “tingling” type sensates can be found in U.S. Patent No. 6,780,443, the entire contents of which are incorporated herein by reference for all purposes.

[00100] Sensate components may also be referred to as “trigeminal stimulants” such as those disclosed in U.S. Patent Application No. 205/0202118, which is incorporated herein by reference. Trigeminal stimulants are defined as an orally consumed product or agent that stimulates the trigeminal nerve. Examples of cooling agents which are trigeminal stimulants include menthol, WS-3, N-substituted p-menthane carboxamide, acyclic carboxamides including WS-23, methyl succinate, menthone glycerol ketals, bulk sweeteners such as xylitol, erythritol, dextrose, and sorbitol, and combinations thereof. Trigeminal stimulants can also include flavors, tingling agents, Jambu extract, vanillyl alkyl ethers, such as vanillyl n-butyl ether, spilanthol, Echinacea extract, Northern Prickly Ash extract, capsaicin, capsicum oleoresin, red pepper oleoresin, black pepper oleoresin, piperine, ginger oleoresin, gingerol, shoagol, cinnamon oleoresin, cassia oleoresin, cinnamic aldehyde, eugenol, cyclic acetal of vanillin and menthol glycerin ether, unsaturated amides, and combinations thereof.

[00101] In some embodiments, sensate components are used at levels that provide a perceptible sensory experience i.e. at or above their threshold levels. In other embodiments, sensate components are used at levels below their threshold levels such that they do not

provide an independent perceptible sensory experience. At subthreshold levels, the sensates may provide an ancillary benefit such as flavor or sweetness enhancement or potentiation.

[00102] Potentiator Ingredients

[00103] Potentiators can include of materials that may intensify, supplement, modify or enhance the taste and/or aroma perception of an original material without introducing a characteristic taste and/or aroma perception of their own. In some embodiments, potentiators designed to intensify, supplement, modify, or enhance the perception of flavor, sweetness, tartness, umami, kokumi, saltiness and combinations thereof can be included.

[00104] In some embodiments, examples of suitable potentiators, also known as taste potentiators include, but are not limited to, neohesperidin dihydrochalcone, chlorogenic acid, alapyridaine, cynarin, miraculin, glupyridaine, pyridinium-betain compounds, glutamates, such as monosodium glutamate and monopotassium glutamate, neotame, thaumatin, tagatose, trehalose, salts, such as sodium chloride, monoammonium glycyrrhizinate, vanilla extract (in ethyl alcohol), sugar acids, potassium chloride, sodium acid sulfate, hydrolyzed vegetable proteins, hydrolyzed animal proteins, yeast extracts, adenosine monophosphate (AMP), glutathione, nucleotides, such as inosine monophosphate, disodium inosinate, xanthosine monophosphate, guanylate monophosphate, alapyridaine (N-(1-carboxyethyl)-6-(hydroxymethyl)pyridinium-3-ol inner salt, sugar beet extract (alcoholic extract), sugarcane leaf essence (alcoholic extract), curcumin, strogin, mabinlin, gymnemic acid, hydroxybenzoic acids, 3-hydrobenzoic acid, 2,4-dihydrobenzoic acid, citrus aurantium, vanilla oleoresin, sugarcane leaf essence, maltol, ethyl maltol, vanillin, licorice glycyrrhizates, compounds that respond to G-protein coupled receptors (T2Rs and T1Rs) and taste potentiator compositions that impart kokumi, as disclosed in U.S. Patent No. 5,679,397 to Kuroda et al., which is incorporated in its entirety herein by reference. "Kokumi" refers to materials that impart "mouthfulness" and "good body".

[00105] Sweetener potentiators, which are a type of taste potentiator, enhance the taste of sweetness. In some embodiments, exemplary sweetener potentiators include, but are not limited to, monoammonium glycyrrhizinate, licorice glycyrrhizates, citrus aurantium, alapyridaine, alapyridaine (N-(1-carboxyethyl)-6-(hydroxymethyl)pyridinium-3-ol) inner salt, miraculin, curcumin, strogin, mabinlin, gymnemic acid, cynarin, glupyridaine, pyridinium-betain compounds, sugar beet extract, neotame, thaumatin, neohesperidin dihydrochalcone, hydroxybenzoic acids, tagatose, trehalose, maltol, ethyl maltol, vanilla extract, vanilla oleoresin, vanillin, sugar beet extract (alcoholic extract), sugarcane leaf essence (alcoholic

extract), compounds that respond to G-protein coupled receptors (T2Rs and T1Rs) and combinations thereof.

[00106] Additional examples of potentiators for the enhancement of salt taste include acidic peptides, such as those disclosed in U.S. Patent No. 6,974,597, herein incorporated by reference. Acidic peptides include peptides having a larger number of acidic amino acids, such as aspartic acid and glutamic acid, than basic amino acids, such as lysine, arginine and histidine. The acidic peptides are obtained by peptide synthesis or by subjecting proteins to hydrolysis using endopeptidase, and if necessary, to deamidation. Suitable proteins for use in the production of the acidic peptides or the peptides obtained by subjecting a protein to hydrolysis and deamidation include plant proteins, (e.g. wheat gluten, corn protein (e.g., zein and gluten meal), soybean protein isolate), animal proteins (e.g., milk proteins such as milk casein and milk whey protein, muscle proteins such as meat protein and fish meat protein, egg white protein and collagen), and microbial proteins (e.g., microbial cell protein and polypeptides produced by microorganisms).

[00107] The sensation of warming or cooling effects may also be prolonged with the use of a hydrophobic sweetener as described in U.S. Patent Application Publication 2003/0072842 A1 which is incorporated in its entirety herein by reference.

[00108] Food Acid Ingredients

[00109] Acids can include, but are not limited to acetic acid, adipic acid, ascorbic acid, butyric acid, citric acid, formic acid, fumaric acid, glyconic acid, lactic acid, phosphoric acid, malic acid, oxalic acid, succinic acid, tartaric acid, aspartic acid, benzoic acid, caffeotannic acid, iso-citric acid, citramalic acid, galacturonic acid, glucuronic acid, glyceric acid, glycolic acid, ketoglutaric acid, a-ketoglutaric acid, lactoisocitric acid, oxalacetic acid, pyruvic acid, quinic acid, shikimic acid, succinic acid, tannic acid, hydroxyacetic acid, suberic acid, sebacic acid, azelaic acid, pimelic acid, capric acid and combinations thereof.

[00110] Emulsifiers

[00111] The gum structure may also include emulsifiers which aid in dispersing the immiscible components into a single stable system. The emulsifiers useful in this invention include glyceryl monostearate, lecithin, fatty acid monoglycerides, diglycerides, propylene glycol monostearate, methyl cellulose, alginates, carrageenan, xanthan gum, gelatin, carob, tragacanth, locust bean gum, pectin, alginates, galactomannans such as guar gum, carob bean gum, glucomannan, gelatin, starch, starch derivatives, dextrans and cellulose derivatives such as carboxy methyl cellulose, acidulants such as malic acid, adipic acid, citric acid, tartaric acid, fumaric acid, and the like, used alone and mixtures thereof. The emulsifier may be

employed in amounts from about 2% to about 15%, and more specifically, from about 7% to about 11%, by weight of the gum structure.

[00112] Colors

[00113] Coloring agents may be used in amounts effective to produce the desired color. The coloring agents may include pigments which may be incorporated in amounts up to about 6%, by weight of the gum. For example, titanium dioxide may be incorporated in amounts up to about 2%, and preferably less than about 1%, by weight of the gum structure. The colorants may also include natural food colors and dyes suitable for food, drug and cosmetic applications. These colorants are known as F.D.& C. dyes and lakes. The materials acceptable for the foregoing uses are preferably water-soluble. Illustrative nonlimiting examples include the indigoid dye known as F.D.& C. Blue No.2, which is the disodium salt of 5,5-indigotindisulfonic acid. Similarly, the dye known as F.D.& C. Green No.1 comprises a triphenylmethane dye and is the monosodium salt of 4-[4-(N-ethyl-p-sulfoniumbenzylamino) diphenylmethylene]-[1-(N-ethyl -N-p-sulfoniumbenzyl)-delta-2,5-cyclohexadieneimine]. A full recitation of all F.D.& C. colorants and their corresponding chemical structures may be found in the Kirk-Othmer Encyclopedia of Chemical Technology, 3rd Edition, in volume 5 at pages 857-884, which text is incorporated herein by reference.

[00114] As classified by the United States Food, Drug, and Cosmetic Act (21 C.F.R. 73), colors can include exempt from certification colors (sometimes referred to as natural even though they can be synthetically manufactured) and certified colors (sometimes referred to as artificial), or combinations thereof. In some embodiments, exempt from certification or natural colors can include, but are not limited to annatto extract, (E160b), bixin, norbixin, astaxanthin, dehydrated beets (beet powder), beetroot red/betanin (E162), ultramarine blue, canthaxanthin (E161g), cryptoxanthin (E161c), rubixanthin (E161d), violanxanthin (E161e), rhodoxanthin (E161f), caramel (E150(a-d)), β -apo-8'-carotenal (E160e), β -carotene (E160a), alpha carotene, gamma carotene, ethyl ester of beta-apo-8 carotenal (E160f), flavoxanthin (E161a), lutein (E161b), cochineal extract (E120); carmine (E132), carmoisine/azorubine (E122), sodium copper chlorophyllin (E141), chlorophyll (E140), toasted partially defatted cooked cottonseed flour, ferrous gluconate, ferrous lactate, grape color extract, grape skin extract (enocianina), anthocyanins (E163), haematococcus algae meal, synthetic iron oxide, iron oxides and hydroxides (E172), fruit juice, vegetable juice, dried algae meal, tagetes (Aztec marigold) meal and extract, carrot oil, corn endosperm oil, paprika, paprika oleoresin, phaffia yeast, riboflavin (E101), saffron, titanium dioxide, turmeric (E100), turmeric

oleoresin, amaranth (E123), capsanthin/capsorbin (E160c), lycopene (E160d), and combinations thereof.

[00115] In some embodiments, certified colors can include, but are not limited to, FD&C blue #1, FD&C blue #2, FD&C green #3, FD&C red #3, FD&C red #40, FD&C yellow #5 and FD&C yellow #6, tartrazine (E102), quinoline yellow (E104), sunset yellow (E110), ponceau (E124), erythrosine (E127), patent blue V (E131), titanium dioxide (E171), aluminium (E173), silver (E174), gold (E175), pigment rubine/lithol rubine BK (E180), calcium carbonate (E170), carbon black (E153), black PN/brilliant black BN (E151), green S/acid brilliant green BS (E142), and combinations thereof. In some embodiments, certified colors can include FD&C aluminum lakes. These include of the aluminum salts of FD&C dyes extended on an insoluble substrate of alumina hydrate. Additionally, in some embodiments, certified colors can be included as calcium salts.

[00116] Functional Ingredients

[00117] Additional additives including functional ingredients include physiological cooling agents, throat-soothing agents, spices, warming agents, tooth-whitening agents or other dental care ingredients, breath-freshening agents, vitamins, nutraceuticals, phytochemicals, polyphenols, antioxidants, active ingredients, minerals, caffeine, drugs and other actives may also be included in the gum composition. Such components may be used in amounts sufficient to achieve their intended effects and will be more fully discussed below.

[00118] Breath Freshening Ingredients

[00119] Breath fresheners can include essential oils as well as various aldehydes, alcohols, and similar materials. In some embodiments, essential oils can include oils of spearmint, peppermint, wintergreen, sassafras, chlorophyll, citral, geraniol, cardamom, clove, sage, carvacrol, eucalyptus, cardamom, magnolia bark extract, marjoram, cinnamon, lemon, lime, grapefruit, and orange. In some embodiments, aldehydes such as cinnamic aldehyde and salicylaldehyde can be used. Additionally, chemicals such as menthol, carvone, iso-garrigol, and anethole can function as breath fresheners. Of these, the most commonly employed are oils of peppermint, spearmint and chlorophyll.

[00120] In addition to essential oils and chemicals derived from them, in some embodiments breath fresheners can include but are not limited to zinc citrate, zinc acetate, zinc fluoride, zinc ammonium sulfate, zinc bromide, zinc iodide, zinc chloride, zinc nitrate, zinc fluosilicate, zinc gluconate, zinc tartarate, zinc succinate, zinc formate, zinc chromate, zinc phenol sulfonate, zinc dithionate, zinc sulfate, silver nitrate, zinc salicylate, zinc

glycerophosphate, copper nitrate, chlorophyll, copper chlorophyll, chlorophyllin, hydrogenated cottonseed oil, chlorine dioxide, beta cyclodextrin, zeolite, silica-based materials, carbon-based materials, enzymes such as laccase, and combinations thereof.

[00121] In some embodiments, the release profiles of probiotics can be managed for a gum structure including, but not limited to lactic acid producing microorganisms such as *Bacillus coagulans*, *Bacillus subtilis*, *Bacillus laterosporus*, *Bacillus laevolacticus*, *Sporolactobacillus inulinus*, *Lactobacillus acidophilus*, *Lactobacillus curvatus*, *Lactobacillus plantarum*, *Lactobacillus jensenii*, *Lactobacillus casei*, *Lactobacillus fermentum*, *Lactococcus lactis*, *Pediococcus acidilacti*, *Pediococcus pentosaceus*, *Pediococcus urinae*, *Leuconostoc mesenteroides*, *Bacillus coagulans*, *Bacillus subtilis*, *Bacillus laterosporus*, *Bacillus laevolacticus*, *Sporolactobacillus inulinus* and mixtures thereof. Breath fresheners are also known by the following trade names: Retsyn,TM Actizol,TM and Nutrazin.TM Examples of malodor-controlling compositions are also included in U.S. Patent No. 5,300,305 to Stapler et al. and in U.S. Patent Application Publication Nos. 2003/0215417 and 2004/0081713 which are incorporated in their entirety herein by reference for all purposes.

[00122] Dental Care Ingredients

[00123] Dental care ingredients (also known as oral care ingredients) may include but are not limited to tooth whiteners, stain removers, oral cleaning, bleaching agents, desensitizing agents, dental remineralization agents, antibacterial agents, anticaries agents, plaque acid buffering agents, surfactants and anticalculus agents. Non-limiting examples of such ingredients can include, hydrolytic agents including proteolytic enzymes, abrasives such as hydrated silica, calcium carbonate, sodium bicarbonate and alumina, other active stain-removing components such as surface-active agents, including, but not limited to anionic surfactants such as sodium stearate, sodium palmitate, sulfated butyl oleate, sodium oleate, salts of fumaric acid, glycerol, hydroxylated lecithin, sodium lauryl sulfate and chelators such as polyphosphates, which are typically employed as tartar control ingredients. In some embodiments, dental care ingredients can also include tetrasodium pyrophosphate and sodium tri-polyphosphate, sodium bicarbonate, sodium acid pyrophosphate, sodium tripolyphosphate, xylitol, sodium hexametaphosphate.

[00124] In some embodiments, peroxides such as carbamide peroxide, calcium peroxide, magnesium peroxide, sodium peroxide, hydrogen peroxide, and peroxydiphosphate are included. In some embodiments, potassium nitrate and potassium citrate are included. Other examples can include casein glycomacropeptide, calcium casein peptone-calcium phosphate, casein phosphopeptides, casein phosphopeptide-amorphous calcium phosphate (CPP-ACP),

and amorphous calcium phosphate. Still other examples can include papaine, krillase, pepsin, trypsin, lysozyme, dextranase, mutanase, glycoamylase, amylase, glucose oxidase, and combinations thereof.

[00125] Further examples can include surfactants such as sodium stearate, sodium ricinoleate, and sodium lauryl sulfate surfactants for use in some embodiments to achieve increased prophylactic action and to render the dental care ingredients more cosmetically acceptable. Surfactants can preferably be deterative materials which impart to the composition deterative and foaming properties. Suitable examples of surfactants are water-soluble salts of higher fatty acid monoglyceride monosulfates, such as the sodium salt of the monosulfated monoglyceride of hydrogenated coconut oil fatty acids, higher alkyl sulfates such as sodium lauryl sulfate, alkyl aryl sulfonates such as sodium dodecyl benzene sulfonate, higher alkyl sulfoacetates, sodium lauryl sulfoacetate, higher fatty acid esters of 1,2-dihydroxy propane sulfonate, and the substantially saturated higher aliphatic acyl amides of lower aliphatic amino carboxylic acid compounds, such as those having 12 to 16 carbons in the fatty acid, alkyl or acyl radicals, and the like. Examples of the last mentioned amides are N-lauroyl sarcosine, and the sodium, potassium, and ethanolamine salts of N-lauroyl, N-myristoyl, or N-palmitoyl sarcosine.

[00126] In addition to surfactants, dental care ingredients can include antibacterial agents such as, but not limited to, triclosan, chlorhexidine, zinc citrate, silver nitrate, copper, limonene, and cetyl pyridinium chloride. In some embodiments, additional anticaries agents can include fluoride ions or fluorine-providing components such as inorganic fluoride salts. In some embodiments, soluble alkali metal salts, for example, sodium fluoride, potassium fluoride, sodium fluorosilicate, ammonium fluorosilicate, sodium monofluorophosphate, as well as tin fluorides, such as stannous fluoride and stannous chloride can be included. In some embodiments, a fluorine-containing compound having a beneficial effect on the care and hygiene of the oral cavity, e.g., diminution of enamel solubility in acid and protection of the teeth against decay may also be included as an ingredient. Examples thereof include sodium fluoride, stannous fluoride, potassium fluoride, potassium stannous fluoride (SnF₂·2KF), sodium hexafluorostannate, stannous chlorofluoride, sodium fluorozirconate, and sodium monofluorophosphate. In some embodiments, urea is included.

[00127] Further examples are included in the following U.S. patents and U.S. published patent applications, the contents of all of which are incorporated in their entirety herein by reference for all purposes: U.S. Patent Nos. 5,227,154 to Reynolds, 5,378,131 to Greenberg, 6,846,500 to Luo et al., 6,733,818 to Luo et al., 6,696,044 to Luo et al., 6,685,916 to Holme

et al., 6,485,739 to Luo et al., 6,479,071 to Holme et al., 6,471,945 to Luo et al., U.S. Patent Publication Nos. 20050025721 to Holme et al., 2005008732 to Gebreselassie et al., and 20040136928 to Holme et al.

[00128] Active Ingredients

[00129] Actives generally refer to those ingredients that are included in a delivery system and/or gum structure for the desired end benefit they provide to the user. In some embodiments, actives can include medicaments, nutrients, nutraceuticals, herbals, nutritional supplements, pharmaceuticals, drugs, and the like and combinations thereof.

[00130] Examples of useful drugs include ace-inhibitors, antianginal drugs, anti-arrhythmias, anti-asthmatics, anti-cholesterolemics, analgesics, anesthetics, anti-convulsants, anti-depressants, anti-diabetic agents, anti-diarrhea preparations, antidotes, anti-histamines, anti-hypertensive drugs, anti-inflammatory agents, anti-lipid agents, anti-manics, anti-nauseants, anti-stroke agents, anti-thyroid preparations, anti-tumor drugs, anti-viral agents, acne drugs, alkaloids, amino acid preparations, anti-tussives, anti-uricemic drugs, anti-viral drugs, anabolic preparations, systemic and non-systemic anti-infective agents, anti-neoplastics, anti-parkinsonian agents, anti-rheumatic agents, appetite stimulants, biological response modifiers, blood modifiers, bone metabolism regulators, cardiovascular agents, central nervous system stimulates, cholinesterase inhibitors, contraceptives, decongestants, dietary supplements, dopamine receptor agonists, endometriosis management agents, enzymes, erectile dysfunction therapies such as sildenafil citrate, which is currently marketed as Viagra™, fertility agents, gastrointestinal agents, homeopathic remedies, hormones, hypercalcemia and hypocalcemia management agents, immunomodulators, immunosuppressives, migraine preparations, motion sickness treatments, muscle relaxants, obesity management agents, osteoporosis preparations, oxytocics, parasympatholytics, parasympathomimetics, prostaglandins, psychotherapeutic agents, respiratory agents, sedatives, smoking cessation aids such as bromocryptine or nicotine, sympatholytics, tremor preparations, urinary tract agents, vasodilators, laxatives, antacids, ion exchange resins, anti-pyretics, appetite suppressants, expectorants, anti-anxiety agents, anti-ulcer agents, anti-inflammatory substances, coronary dilators, cerebral dilators, peripheral vasodilators, psychotropics, stimulants, anti-hypertensive drugs, vasoconstrictors, migraine treatments, antibiotics, tranquilizers, anti-psychotics, anti-tumor drugs, anti-coagulants, anti-thrombotic drugs, hypnotics, anti-emetics, anti-nauseants, anti-convulsants, neuromuscular drugs, hyper- and hypo-glycemic agents, thyroid and anti-thyroid preparations, diuretics, anti-spasmodics,

terine relaxants, anti-obesity drugs, erythropoietic drugs, anti-asthmatics, cough suppressants, mucolytics, DNA and genetic modifying drugs, and combinations thereof.

[00131] Examples of active ingredients contemplated for use in some embodiments can include antacids, H₂-antagonists, and analgesics. For example, antacid dosages can be prepared using the ingredients calcium carbonate alone or in combination with magnesium hydroxide, and/or aluminum hydroxide. Moreover, antacids can be used in combination with H₂-antagonists.

[00132] Analgesics include opiates and opiate derivatives, such as Oxycontin™, ibuprofen, aspirin, acetaminophen, and combinations thereof that may optionally include caffeine.

[00133] Other drug active ingredients for use in embodiments can include anti-diarrheals such as Immodium™ AD, anti-histamines, anti-tussives, decongestants, vitamins, and breath fresheners. Also contemplated for use herein are anxiolytics such as Xanax™; anti-psychotics such as Clozaril™ and Haldol™; non-steroidal anti-inflammatories (NSAID's) such as ibuprofen, naproxen sodium, Voltaren™ and Lodine™, anti-histamines such as Claritin™, Hismanal™, Relafen™, and Tavist™; anti-emetics such as Kytril™ and Cesamet™; bronchodilators such as Bentolin™, Proventil™; anti-depressants such as Prozac™, Zoloft™, and Paxil™; anti-migraines such as Imigra™, ACE-inhibitors such as Vasotec™, Capoten™ and Zestril™; anti-Alzheimer's agents, such as Nicergoline™; and CaH-antagonists such as Procardia™, Adalat™, and Calan™.

[00134] The popular H₂-antagonists which are contemplated for use in the present invention include cimetidine, ranitidine hydrochloride, famotidine, nizatidien, ebrotidine, mifentidine, roxatidine, pisatidine and aceroxatidine.

[00135] Active antacid ingredients can include, but are not limited to, the following: aluminum hydroxide, dihydroxyaluminum aminoacetate, aminoacetic acid, aluminum phosphate, dihydroxyaluminum sodium carbonate, bicarbonate, bismuth aluminate, bismuth carbonate, bismuth subcarbonate, bismuth subgallate, bismuth subnitrate, bismuth subsilylsilate, calcium carbonate, calcium phosphate, citrate ion (acid or salt), amino acetic acid, hydrate magnesium aluminate sulfate, magaldrate, magnesium aluminosilicate, magnesium carbonate, magnesium glycinate, magnesium hydroxide, magnesium oxide, magnesium trisilicate, milk solids, aluminum mono-ordibasic calcium phosphate, tricalcium phosphate, potassium bicarbonate, sodium tartrate, sodium bicarbonate, magnesium aluminosilicates, tartaric acids and salts.

[00136] A variety of nutritional supplements may also be used as active ingredients including virtually any vitamin or mineral. For example, vitamin A, vitamin C, vitamin D, vitamin E, vitamin K, vitamin B6, vitamin B12, thiamine, riboflavin, biotin, folic acid, niacin, pantothenic acid, sodium, potassium, calcium, magnesium, phosphorus, sulfur, chlorine, iron, copper, iodine, zinc, selenium, manganese, choline, chromium, molybdenum, fluorine, cobalt and combinations thereof, may be used.

[00137] Examples of nutritional supplements that can be used as active ingredients are set forth in U.S. Patent Application Publication Nos. 2003/0157213 A1, 2003/0206993 and 2003/0099741 A1 which are incorporated in their entirety herein by reference for all purposes.

[00138] Various herbals may also be used as active ingredients such as those with various medicinal or dietary supplement properties. Herbals are generally aromatic plants or plant parts and or extracts thereof that can be used medicinally or for flavoring. Suitable herbals can be used singly or in various mixtures. Commonly used herbs include Echinacea, Goldenseal, Calendula, Rosemary, Thyme, Kava Kava, Aloe, Blood Root, Grapefruit Seed Extract, Black Cohosh, Ginseng, Guarana, Cranberry, Ginkgo Biloba, St. John's Wort, Evening Primrose Oil, Yohimbe Bark, Green Tea, Ma Huang, Maca, Bilberry, Lutein, and combinations thereof.

[00139] Effervescing System Ingredients

[00140] An effervescent system may include one or more edible acids and one or more edible alkaline materials. The edible acid(s) and the edible alkaline material(s) may react together to generate effervescence.

[00141] In some embodiments, the alkaline material(s) may be selected from, but is not limited to, alkali metal carbonates, alkali metal bicarbonates, alkaline earth metal carbonates, alkaline earth metal bicarbonates, and combinations thereof. The edible acid(s) may be selected from, but is not limited to, citric acid, phosphoric acid, tartaric acid, malic acid, ascorbic acid, and combinations thereof. In some embodiments, an effervescing system may include one or more other ingredients such as, for example, carbon dioxide, oral care ingredients, flavorants, etc.

[00142] For examples of use of an effervescing system in a gum, refer to U.S. Provisional Patent No. 60/618,222 filed October 13, 2004, and entitled "Effervescent Pressed Confectionery Tablet Compositions," the contents of which are incorporated herein by reference for all purposes. Other examples can be found in U.S. Patent No. 6,235,318, the contents of which are incorporated herein by reference for all purposes.

[00143] Appetite Suppressor Ingredients

[00144] Appetite suppressors can be ingredients such as fiber and protein that function to depress the desire to consume food. Appetite suppressors can also include benzphetamine, diethylpropion, mazindol, phendimetrazine, phentermine, hoodia (P57), Olibra,TM ephedra, caffeine and combinations thereof. Appetite suppressors are also known by the following trade names: Adipex,TM Adipost,TM BontrilTM PDM, BontrilTM Slow Release, Didrex,TM Fastin,TM Ionamin,TM Mazanor,TM Melfiat,TM Obenix,TM Phendiet,TM Phendiet-105,TM Phentercot,TM Phentride,TM Plegine,TM Prelu-2,TM Pro-Fast,TM PT 105,TM Sanorex,TM Tenuate,TM Sanorex,TM Tenuate,TM Tenuate Dospan,TM Tepanil Ten-Tab,TM Teramine,TM and Zantryl.TM These and other suitable appetite suppressors are further described in the following U.S. patents, all of which are incorporated in their entirety by reference hereto: U.S. 6,838,431 to Portman, U.S. 6,716,815 to Portman, U.S. 6,558,690 to Portman, U.S. 6,468,962 to Portman, U.S. 6,436,899 to Portman.

[00145] Micronutrient Ingredients

[00146] Micronutrients can include materials that have an impact on the nutritional well being of an organism even though the quantity required by the organism to have the desired effect is small relative to macronutrients such as protein, carbohydrate, and fat. Micronutrients can include, but are not limited to vitamins, minerals, enzymes, phytochemicals, antioxidants, and combinations thereof.

[00147] In some embodiments, vitamins can include fat soluble vitamins such as vitamin A, vitamin D, vitamin E, and vitamin K and combinations thereof. In some embodiments, vitamins can include water soluble vitamins such as vitamin C (ascorbic acid), the B vitamins (thiamine or B1, riboflavin or B2, niacin or B3, pyridoxine or B6, folic acid or B9, cyanocobalamin or B12, pantothenic acid, biotin), and combinations thereof.

[00148] In some embodiments minerals can include but are not limited to sodium, magnesium, chromium, iodine, iron, manganese, calcium, copper, fluoride, potassium, phosphorous, molybdenum, selenium, zinc, and combinations thereof.

[00149] In some embodiments micronutrients can include but are not limited to L-carnitine, choline, coenzyme Q10, alpha-lipoic acid, omega-3-fatty acids, pepsin, phytase, trypsin, lipases, proteases, cellulases, and combinations thereof.

[00150] In some embodiments phytochemicals can include but are not limited to carotenoids, chlorophyll, chlorophyllin, fiber, flavanoids, anthocyanins, cyaniding, delphinidin, malvidin, pelargonidin, peonidin, petunidin, flavanols, catechin, epicatechin, epigallocatechin, epigallocatechingallate (EGCG), theaflavins, thearubigins, proanthocyanins,

flavonols, quercetin, kaempferol, myricetin, isorhamnetin, flavononeshesperetin, naringenin, eriodictyol, tangeretin, flavones, apigenin, luteolin, lignans, phytoestrogens, resveratrol, isoflavones, daidzein, genistein, glycitein, soy isoflavones, and combinations thereof.

[00151] Mouth Moistening Ingredients

[00152] Mouth moisteners can include, but are not limited to, saliva stimulators such as acids and salts and combinations thereof. In some embodiments, acids can include acetic acid, adipic acid, ascorbic acid, butyric acid, citric acid, formic acid, fumaric acid, glyconic acid, lactic acid, phosphoric acid, malic acid, oxalic acid, succinic acid, tartaric acid and combinations thereof. In some embodiments, salts can include sodium chloride, calcium chloride, potassium chloride, magnesium chloride, sea salt, sodium citrate, and combinations thereof.

[00153] Mouth moisteners can also include hydrocolloid materials that hydrate and may adhere to oral surface to provide a sensation of mouth moistening. Hydrocolloid materials can include naturally occurring materials such as plant exudates, seed confectionerys, and seaweed extracts or they can be chemically modified materials such as cellulose, starch, or natural confectionery derivatives. In some embodiments, hydrocolloid materials can include pectin, gum arabic, acacia gum, alginates, agar, carageenans, guar gum, xanthan gum, locust bean gum, gelatin, gellan gum, galactomannans, tragacanth gum, karaya gum, curdlan, konjac, chitosan, xyloglucan, beta glucan, furcellaran, gum ghatti, tamarin, bacterial gums, and combinations thereof. Additionally, in some embodiments, modified natural gums such as propylene glycol alginate, carboxymethyl locust bean gum, low methoxyl pectin, and their combinations can be included. In some embodiments, modified celluloses can be included such as microcrystalline cellulose, carboxymethylcellulose (CMC), methylcellulose (MC), hydroxypropylmethylcellulose (HPCM), and hydroxypropylcellulose (MPC), and combinations thereof.

[00154] Similarly, humectants which can provide a perception of mouth hydration can be included. Such humectants can include, but are not limited to glycerol, sorbitol, polyethylene glycol, erythritol, and xylitol. Additionally, in some embodiments, fats can provide a perception of mouth moistening. Such fats can include medium chain triglycerides, vegetable oils, fish oils, mineral oils, and combinations thereof.

[00155] Throat Care Ingredients

[00156] Throat soothing ingredients can include analgesics, anesthetics, demulcents, antiseptic, and combinations thereof. In some embodiments, analgesics/anesthetics can include menthol, phenol, hexylresorcinol, benzocaine, dyclonine hydrochloride, benzyl

alcohol, salicyl alcohol, and combinations thereof. In some embodiments, demulcents can include but are not limited to slippery elm bark, pectin, gelatin, and combinations thereof. In some embodiments, antiseptic ingredients can include cetylpyridinium chloride, domiphen bromide, dequalinium chloride, and combinations thereof.

[00157] In some embodiments, antitussive ingredients such as chlorphedianol hydrochloride, codeine, codeine phosphate, codeine sulfate, dextromethorphan, dextromethorphan hydrobromide, diphenhydramine citrate, and diphenhydramine hydrochloride, and combinations thereof can be included.

[00158] In some embodiments, throat soothing agents such as honey, propolis, aloe vera, glycerine, menthol and combinations thereof can be included. In still other embodiments, cough suppressants can be included. Such cough suppressants can fall into two groups: those that alter the consistency or production of phlegm such as mucolytics and expectorants; and those that suppress the coughing reflex such as codeine (narcotic cough suppressants), antihistamines, dextromethorphan and isoproterenol (non-narcotic cough suppressants). In some embodiments, ingredients from either or both groups can be included.

[00159] In still other embodiments, antitussives can include, but are not limited to, the group consisting of codeine, dextromethorphan, dextropropranolol, diphenhydramine, hydrocodone, noscapine, oxycodone, pentoxifylline and combinations thereof. In some embodiments, antihistamines can include, but are not limited to, acrivastine, azatadine, brompheniramine, chlorpheniramine, clemastine, cyproheptadine, dexbrompheniramine, dimenhydrinate, diphenhydramine, doxylamine, hydroxyzine, meclizine, phenindamine, phenyltoloxamine, promethazine, pyrillamine, triprolidine, triprolidine and combinations thereof. In some embodiments, non-sedating antihistamines can include, but are not limited to, astemizole, cetirizine, ebastine, fexofenadine, loratidine, terfenadine, and combinations thereof.

[00160] In some embodiments, expectorants can include, but are not limited to, ammonium chloride, guaifenesin, ipecac fluid extract, potassium iodide and combinations thereof. In some embodiments, mucolytics can include, but are not limited to, acetylcysteine, ambroxol, bromhexine and combinations thereof. In some embodiments, analgesic, antipyretic and anti-inflammatory agents can include, but are not limited to, acetaminophen, aspirin, diclofenac, diflunisal, etodolac, fenoprofen, flurbiprofen, ibuprofen, ketoprofen, ketorolac, nabumetone, naproxen, piroxicam, caffeine and mixtures thereof. In some embodiments, local anesthetics can include, but are not limited to, lidocaine, benzocaine, phenol, dyclonine, benzonotatate and mixtures thereof.

[00161] In some embodiments nasal decongestants and ingredients that provide the perception of nasal clearing can be included. In some embodiments, nasal decongestants can include but are not limited to phenylpropanolamine, pseudoephedrine, ephedrine, phenylephrine, oxymetazoline, and combinations thereof. In some embodiments ingredients that provide a perception of nasal clearing can include but are not limited to menthol, camphor, borneol, ephedrine, eucalyptus oil, peppermint oil, methyl salicylate, bornyl acetate, lavender oil, wasabi extracts, horseradish extracts, and combinations thereof. In some embodiments, a perception of nasal clearing can be provided by odoriferous essential oils, extracts from woods, confectioneries, flowers and other botanicals, resins, animal secretions, and synthetic aromatic materials.

[00162] In some embodiments, optional or functional ingredients can include breath fresheners, dental care components, actives, herbals, effervescing systems, appetite suppressors, vitamins, micronutrients, mouth moistening components, throat care components, energy boosting agents, concentration boosting agents, and combinations thereof.

[00163] In some embodiments, the modified release component includes at least one ingredient selected from the group comprising flavors, sweeteners, sensates, breath fresheners, dental care components, actives, herbals, effervescing systems, appetite suppressors, potentiators, food acids, micronutrients, mouth moistening components, throat care components, and combinations thereof. These ingredients can be in encapsulated form, in free form, or both.

[00164] EXAMPLES OF FINISHED CHEWING GUM COMPOSITIONS

Table 1: Chewing Gum Composition

Component	% by weight							
	Formula 1	Formula 2	Formula 3	Formula 4	Formula 5	Formula 6	Formula 7	Formula 8
Gum base*	28-42	28-42	28-42	28-42	28-42	28-42	28-42	28-42
Lecithin	0.25	0.25	0.05	0.05	0.05	0.05	0.05	0.05
Maltitol	52-55	45-50	0	50-54	52-57	45-55	47-52	0
Sorbitol	0	0-10	0	0-5	0-5	5-10	0-5	0
Lycasin™	0	0	0	0.25	0.25	0.25	0.25	0
Erythritol	0	0	15-30	0	0	0	0	0

Sugar	0	0	20-40	0	0	0	0	30-55
Corn Syrup	0	0	2-15	0	0	0	0	2-15
Flavors	2.50	2.50	2.26	2.26	2.26	2.50	2.50	2.50
Cooling agent	0.08	0.08	0	0	0	0.08	0.08	0.08
Acidulants	1.2	1.2	0	0	0	1.2	1.2	1.2
Intense sweetener	3.40	3.40	1.70	3.40	3.40	3.40	3.40	0

*gum base may include 3% to 11% by weight of a filler such as, for example, talc, dicalcium phosphate, and calcium carbonate (the amount of filler in the gum base is based on the weight percent of the gum region composition, for example, in the above compositions Y-FF, if a gum region composition includes 5% filler, the amount of gum base will be 5% less than the range recited in the table, i.e., from 23-37%)

[00165] The compositions for the chewing gums are prepared by first combining talc, where present, with the gum base under heat at about 85°C. This combination is then mixed with the bulk sweeteners, lecithin, and sweetener syrups for six minutes. The flavor blends which include a pre-mix of the flavors and cooling agents are added and mixed for 1 minute. Finally, the acids and intense sweeteners are added and mixed for 5 minutes.

[00166] In addition to the various chewing gums mentioned above, it should be appreciated that the below discussed systems and methods may be used to form and size confectionary or candy, combinations of gum ingredients with confectionary or candy ingredients, and combinations of gum with confectionary or candy, as disclosed in U.S. Patent Publication No. 2008/0166449, International Publication No. WO 2011/044373, and International Publication No. WO 2010/092480 the teachings and disclosures of which are hereby incorporated by reference in their entireties to the extent not inconsistent with the present disclosure.

[00167] GUM MIXERS GENERALLY

[00168] The present invention may be used to form and/or cool or heat a gum structure including various ingredients. Any conventional mixers can be used to mix the gum structure, although different types of mixers used may affect the feed characteristics into the new gum forming system 106 of FIG. 1. For example, different types of preconditioning and low shear extruders may be employed to modify the raw mixer output and generate a regular stream and/or a continuous stream. In either event, it is contemplated that the new gum forming system 106 is readily usable with a variety of mixing systems employed in the industry.

[00169] The mixing system 102 can include one or more mixers depending on a formulation of a desired gum structure. The one or more mixers can provide different types of mixing depending on the ingredients being mixed or the condition of the ingredients being mixed. Two primary types of mixing include distributive and dispersive mixing. Dispersive mixing is typically high shear mixing that breaks up individual ingredients and aggregations of ingredients within a composition into smaller pieces. Distributive mixing is typically lower shear mixing than distributive mixing and is used to distribute the individual ingredients throughout the composition to provide a more uniform composition. Dispersive and distributive mixing are more thoroughly described and discussed in U.S. Patent No. 5,562,936, the teachings and disclosure of which are hereby incorporated in their entireties by reference thereto.

[00170] The mixers of the mixing system 102 may be a continuous mixer or a batch mixer. As used herein, "a continuous mixer", which may also be referred to herein as a "continuous processor", is processing equipment in which the various ingredients used to prepare an effluent are fed substantially continuously into the device while those ingredients are being mixed and removed or ejected from the mixing system. For example, in a continuous mixing extruder, ingredients are substantially continuously introduced through various upstream and downstream feed ports, all the while, the screws, blades, pins, paddles or other mixing elements continue to convey the mixture through the system, all the while mixing the same. At a downstream portion of the extruder, the wholly or partly combined downstream portion of the mass is ejected from the extruder by the force of the mass substantially continually or continually being conveyed. The ejection of the mass from the extruder may be facilitated by inclusion of an external or supplemental pump.

[00171] A continuous mixer may provide dispersive mixing, distributive mixing or a combination of both dispersive mixing and distributive mixing. For example, a continuous mixer in the form of an extruder can have all dispersive mixing elements, all distributive mixing elements, or a combination of dispersive mixing elements and distributive mixing elements. Due to the characteristics and requirements of mixing gum compositions, the dispersive mixing elements are typically upstream of the distributive mixing elements, however, continuous mixers according to the present invention are not limited to that arrangement.

[00172] As used herein, "a batch mixer", which may also be referred to herein as a "batch processor", is processing equipment used to prepare a composition that once the composition is prepared the composition is ejected from the equipment all at once or at least discrete non-

continuous portions of the composition will be ejected at intermittent intervals, but the composition is not continuously ejected during mixing. Typically, individual ingredients or portions of the individual ingredients used to prepare the composition are fed into the device substantially all at one time or in a predetermined temporal sequence in discrete amounts. Individual ingredients added to a batch mixer may be added at different times throughout the mixing cycle such that some ingredients have a residence time substantially equal to the entire length of the mixing cycle while other ingredients have a residence time for only a fraction of the entire length of the mixing cycle. Further, individual ingredients that are used for different purposes throughout the mixing cycle may have different discrete portions of the ingredient added at different times throughout the mixing process. For example, one ingredient may be used to facilitate compounding elastomer as well as may be used as a bulking agent. Such an ingredient may have a first portion added at the beginning of the mixing cycle such that it has a residence time equal to the entire mixing time while a second portion of the same ingredient may be added later in the mixing cycle such that the second portion has a residence time less than the entire mixing time.

[00173] A batch mixer will typically provide either dispersive mixing or distributive mixing. A batch mixer used in practicing the present invention could be configured to provide both dispersive and distributive mixing. For example, it is contemplated that a kettle mixer that includes internal blades could be configured to shift between dispersive and distributive mixing by modifying the pitch or orientation of the blades. Alternatively, the kettle mixer could include multiple sets of blades, such that one set is configured for dispersive mixing while another set is configured for distributive mixing. It is contemplated the mixer would most likely only use one set of the blades at a time to provide one type of mixing at a time.

[00174] In some embodiments, the gum mixing system 102 may include one continuous mixer or one batch mixer. In other embodiments, the gum mixing system 102 may include one or more continuous mixers and/or one or more batch mixers arranged in series and/or parallel. Various parallel and series mixing system arrangements are described in U.S. Patent Application Nos. 12/338,428 and 12/338,682, which are assigned to the present assignee, the disclosures of which are hereby incorporated by reference in their entireties.

[00175] Referring more specifically now to the embodiment shown in FIG. 1, a gum structure output 130 from the gum mixing system 102 may be generally irregular or otherwise a non-uniform thickness of material. The gum forming system 106 can process an elastomer or a finished gum or any gum structures therebetween including any number of

gum base ingredients and/or gum ingredients. Although, the gum structure output 130 can be any gum structure, in this embodiment, the gum structure output 130 is preferably a finished gum. Depending on a formulation of the gum structure, the non-uniform gum structure output 130 can be fed as a gum mass 182 directly into the gum forming system 106 to form a continuous sheet of gum structure having a desired uniform thickness. However, as shown in the embodiment of FIG. 1, the non-uniform gum structure output 130 is further processed into a somewhat uniform shape or width prior to entering the gum forming system 106 as the gum mass 182.

[00176] In the embodiment shown in FIG. 1, the gum structure output 130 is preformed into loaves 132 before being further formed into a continuous web or sheet 184 having a desired width and thickness in the gum forming system 106. As such, this embodiment is shown with the optional loafing machine 104 upstream of the forming system 106. The loafing machine 104 is shown as a low-shear extruder 134. The extruder 134 forces the gum structure output 130 through a forming die, thereby forming a uniform extrusion 136 that may be periodically cut off into separate loaves 132 (alternatively a continuous stream of a generally uniform size may be provided without cutting into loaves). The loaves 132 may have a slight parallelogram shape or be of slight shape variations in width and length, but the thickness of the individual loaves 132 is preferably between about 12 and 127 mm thick (vertically) with the length and width being between about 100 mm and 460 mm. Typically, the output orifice of loafing extruder 104 is relatively large enough so as to be considered "low shear" as opposed to sizing type extruders of the prior art. As a result, a maximum thickness of the output is greater than about 25 mm (e.g. between 25-50 mm) and/or a width, in exemplary embodiment of less than 460 mm. Further, the shape need not be perfectly rectangular (or trapezoidal). Such a loafing machine system is disclosed in U.S. Patent Application No. 12/352,110, which is assigned to the present assignee, the disclosure of which is hereby incorporated by reference in its entirety. Forming the gum structure output 130 into loaves 132 can provide flexibility to a gum line. For example, the downstream forming process may be performed at a later time, or the loaves can be transferred to a different location for further processing or conditioning.

[00177] The loaves 132 are then transferred to the gum forming system 106, wherein the loaves 132 can be compressed into a desired thickness. Alternatively, and as discussed previously, the gum structure output 130 can be fed directly into the gum forming system 106 without being formed into the loaves 132. Yet in a different embodiment, the mixing system 102 may include an extruder equipped with a forming die having a large output orifice

(which minimizes shear stress within the forming die and temperature in the resulting rope) to output a rope of a gum having a somewhat uniform shape. For example, the forming die may be configured to output a continuous web or rope of gum having a thickness greater than about 20 mm. The forming die may be adjustable to produce various widths of the continuous web according to a desired width of the gum sheet 184.

[00178] As shown in FIG. 1, the first illustrated embodiment of the overall system 100 notably does not include a sizing type extruder or multiple rollers for progressively reducing thickness. Thus, one feature and advantage according to some embodiments is that the gum forming system 106 can be used to eliminate sizing type extruding systems that may require high shear in extruding the gum; and can also be used to eliminate the traditional series of size reduction rollers that have been previously used to progressively reduce the thickness from the sizing type extruder. Conventional gum lines including such sizing type extruder is limited to producing a gum sheet having a maximum width of about 220 mm to 460 mm due to the high shear nature of the process.

[00179] In forming a continuous sheet 184 using the gum forming system 106, there is no longer a need to forcibly extrude gum through a defined width rectangular orifice. As a result, one advantage that can be realized is that shear force exerted on the gum may be significantly reduced. As a further result, certain shear sensitive ingredients may remain much more intact, such that either the resulting product may have more shear sensitive ingredient intact in the final product, or a smaller quantity of shear sensitive ingredients need to be added during gum mixing operations, thereby invoking a potential for costs savings or enhanced chewing gum characteristics for the consumer. Shear and temperature sensitive ingredients such as those described above including particular encapsulated sweeteners, flavors and various active pharmaceutical ingredients are contemplated to particularly benefit from the potentially lower shear processing.

[00180] Further, due to the potentially low shear nature of the gum forming system 106, the gum forming system 106 may be operated with substantially less power, for example, potentially less than approximately 1/3 of the energy required to run a conventional rolling and scoring line including a sizing type extruder and series of size reduction rollers, thereby potentially resulting in significant energy savings. Further, by replacing the sizing type extruder and series of size reduction rollers with the gum forming system 106, the embodiment of the present invention can substantially reduce the number of moving parts, which can then minimize any down time from malfunctioning moving parts.

[00181] The gum forming system 106 of the embodiment shown in FIG. 1 includes a pair of moving walls 142. In this embodiment, these walls 142 are a surface 144 of conveyor belt 190, and a surface of roller 146. The conveyor belt 190 and the roller 146 are externally driven, for example by an operably coupled motor. In an exemplary embodiment, each of the walls 142 is provided with a motor, such that a speed of the conveyor belt 190 can be controlled independently from the roller 146.

[00182] Importantly, at least one of the walls 142 includes a planar surface 147 at a point of contacting the gum mass 182, with this surface continuously contacting and transporting the gum sheet 184 (i.e. deformed gum mass 182) from an exit area of a hopper 154 (i.e. mass 182) to a point beyond a downstream extent of the roller 146 (i.e. sheet 184). In the embodiment of Figure 1, the surface 144 of the conveyor belt 190 represents the substantially planar and transportive surface 147, though both walls 142 may be such a surface.

[00183] The hopper 154 may be used for upstream surge control, capacity and feed control. The hopper 154 constrains, accumulates, and feeds the gum mass 182 into an inlet region 164 generally between the walls 142. The hopper 154 can be configured to receive the gum structure output 130, the loaves 132, and/or the somewhat uniform web of gum structure having various web widths, and accumulate the received gum as the non-uniformly shaped gum mass 182. The width of the inlet region 164 of the hopper 154 may be adjusted according to a desired sheet width of a gum sheet 184. In one embodiment, the conveyor surface 144 and roller 146 are configured to accommodate a gum sheet 184 at a width of between about 25 mm to 1 m, or perhaps more. It may be desirable to have a wider sheet of the gum of greater than about 0.6 m in width so as to be able to provide a substantial gum mass volume that can operate at slower speeds while generating sufficient output.

[00184] FIG. 7 shows a top view of the hopper 154 in an exemplary embodiment. As shown, the hopper 154 optionally includes a pair of feed rollers 220, 222 to facilitate pulling of the gum mass 182 through the hopper 154 to the pair of walls 142. The feed rollers 220, 222 of this embodiment are auger rollers having helical blades, which are configured to counter-rotate such that the feed roller 220 rotates counter clockwise and the feed roller 222 rotates clockwise when viewed from a left side 224 of the hopper 154 in FIG. 7. When a gum mass 182, which can be loaves 132 or irregular outputs 130 from a mixer or any other shape, is fed into the hopper 154, the gum mass 182 drops toward the feed rollers 220, 222 via gravity. Then, the feed rollers 220, 222 counter rotate inwardly toward the center, thereby moving the gum mass 182 between the feed rollers 220, 222 and toward the inlet region 164. Further, the helical blades of the feed rollers 220, 222 moves the gum mass 182

along the axis of rotation, thereby directing the gum mass 182 toward each end of the feed rollers 220, 222, as the gum mass 182 is fed between the feed rollers 220, 222. As such, the gum mass 182 is distributed to provide a desired width of exiting gum mass 182 corresponding to a width of the feed rollers 220, 222.

[00185] The gum mass 182 is then transported by the conveyor surface 144 toward the roller 146, wherein the conveyor surface 144 and roller 146 move in the same linear direction, pulling the gum mass 182 between the walls 144, 146 to form and size gum mass 182 as will be explained in more detail below. In other embodiments, the hopper 154 may include more than a pair of feeding rollers to further facilitate feeding and widening of the gum mass 182 in the hopper 154.

[00186] In this embodiment, the pair of walls 142 are vertically offset. More specifically, the roller 146 has a horizontal axis, which is horizontally offset from the planar surface 147 of the conveyor surface 144. The walls 142 are arranged such that a spacing or gap 162 is formed between the walls 142, which allows the gum to pass between therebetween. The pair of walls 142 and the spacing 162 are configured to apply a compressive or deforming force onto the gum mass 182 to form a continuous sheet of gum sheet 184 having a generally uniform thickness corresponding to the spacing 162. The term "a generally uniform thickness" of the gum structure is used broadly herein to describe a cross sectional cross web shape of the gum structure upon exiting the pair of walls 142. As is alluded to above, the conveyor surface 144 transports and remains in continuous contact with the gum from mass form at the inlet area just upstream of the gap 162 to sheet form at areas downstream (i.e. downstream of the roller 146) of the gap 162.

[00187] The conveyor surface 144 and roller 146 are moving in the same linear direction at the gap 162, which can be as narrow as 0.1 mm, allowing the gum mass 182 to be pulled therethrough. The feed rollers 220, 222 may also convey a gum mass entering the hopper 154 toward the transporting surface 147. As the gum mass 182 is pulled through a minimum distance of the gap 162, the gum mass is deformed between the walls 142, with this deforming/sizing being substantially extensional.

[00188] Immediately prior to being sized by the rollers 142 (i.e., exiting the hopper 154), the gum mass 182 is substantially unshaped. It should be noted that an "unshaped" gum mass or sheet 184 may be defined as any mass or sheet 184 that is not, in its current state, sized or formed via extrusion, deforming, or any other means, though the gum mass may have been sized or formed in such a manner prior to being in this current state. In other words, dimension of the gum sheet 184 are created independently of the shape and dimensions of the

unshaped gum mass 182. It should be noted however that the width of the exit from the hopper 154, the gap 162, and the sheet 184 may all be substantially the same. In addition, an exemplary embodiment of the gum mass 182 may include a thickness dimension of greater than 3 times the gum sheet 184, and more particularly 10-70 times the gum sheet 184, at the inlet area 164. In an exemplary embodiment similar to that which is shown in Figure 12, a thickness of the gum mass 182 immediately upstream of the gap 162 is 500-800mm, and a thickness of the gum sheet 184 immediately downstream of the gap 162 is .1-60mm, and more particularly .3-10mm.

[00189] The pair of walls 142 compresses, deforms, and pulls the gum mass 182 through the gap 162 to provide a generally uniform thickness, such that the thickness of the gum sheet 184 is preferably within about 20% cross-web variance, more preferably within about 10% cross-web variance, and most preferably within about a 5% cross-web variance, or less. For example, when a desired thickness of the gum sheet 184 exiting the pair of rollers 142 is 3 mm, the spacing 162 (and particularly the minimum distance of the gap) between the walls 142 is adjusted such that the thickness across the width of the gum sheet 184 is preferably between about 2.4 and 3.6 mm, and more preferably between about 2.7 and 3.3 mm. More preferably, the variance is less than .2 mm and may be about .1 mm. As a result, a significant degree of precision and accuracy can be accomplished with the walls 142 for gum. Some variance is expected with various gum recipes due to variations in bounce back and shrinkage due to variations in elasticity, viscosity and resiliency of a given gum recipe. The gum sheet having a generally uniform thickness may subsequently expand in its thickness or shrink in its thickness depending on a formulation of the gum. Further, the gum sheet 184 having a generally uniform thickness may subsequently be shaped, textured, and/or printed, which may alter the generally uniform thickness.

[00190] The roller 146 can be configured to have various diameters and widths depending on physical properties of the gum, a desired thickness and a width of the gum sheet 184, a desired temperature of the gum sheet 184 exiting the walls 142. In the embodiment shown in FIG. 1, the roller 146 is above the conveyor surface 144, though in other embodiments, the roller may be oriented at the same height or below the conveyor surface. Preferably, the roller 146 has a diameter between about .25 m and 3 m and a width between about 0.3 m and 1.3 m.

[00191] While narrower rollers and conveyor surfaces are possible, those having widths between about 0.3 m and 1.3 m or wider provide an opportunity to produce a gum 184 ribbon or sheet that is about the same in width, typically at least slightly narrower. Therefore, walls

of this width can provide substantial gum capacity improvements over the conventional thickness reduction process involving the sizing type extruder. The pair of walls 142 thus can provide for 125% -300% or more wider gum ribbons or sheet of the finished sized gum than conventional sizing type forming extruder with progressive size reduction rollers, and as noted throughout, while using significantly less energy. Further, the hopper 154, which is configured with the feed rollers 220, 222, and the walls 142 can produce a gum sheet 184 having a desired width within a relatively small variance. In one embodiment, the hopper 154 and the walls 142 can produce a gum sheet having a desired width preferably within 20% variance, more preferably within 10% variance, and most preferably within 5% variance or less.

[00192] With a wider gum material, the speed of the gum forming process can be reduced substantially if desired while still processing the same amount of gum as traditional rolling and scoring lines or higher speeds can be used to result in greater gum volume production. Traditional rolling and scoring lines may operate at a gum conveying speed of 22-25 meters/minute and the same amount of product can be had at speeds that are correspondingly slower as the width increases.

[00193] Depending upon the desired thickness of the gum product, the walls 142 are configured such that the spacing 162 is adjustable preferably between about 0.3 mm to 10.0 mm, although the spacing can be set as low as 0.1 mm. In one embodiment, the conveyor surface 144 and the roller 146 are configured to have a smooth surface finish, and the spacing 162 of less than 0.5 mm to produce a paper thin web of gum having silky smooth surfaces and a thickness less than about 0.5 mm. It should be appreciated that the roller 146 may be configured with a desirable actuation device, such as but not limited to a servomechanism, to control the vertical position of the roller 146 relative to the conveyor surface 144, and thereby adjust the spacing 162.

[00194] The hopper 154 is arranged upstream of the walls 142 such that a portion of the roller 146 and a portion of the conveyor surface 144 proximate the gap 162 define the inlet region 164. The hopper 154 may have a tapered outer wall 166, as well as an opposing inner wall that abuts a surface of the roller 146 with a very small clearance allowing rotation of the roller 146. The tapered outer wall 166 is configured to guide a gum mass 182 in the hopper 154 toward the feed rollers 220, 222. The hopper 154 may also include surfaces configured to rest directly on the conveyor surface 144.

[00195] The roller 146 can run at various rotational speeds resulting in various linear speeds at or in proximity to the gap 162 (linear speeds being measured at a tangent to the

surface of the roller 146 in proximity to the gap 162). The walls 144, 146 can run at a same speed or different speeds (rotational for the roller 146 and linear for the conveyor surface 144), and be selected depending on physical properties of the input gum and an amount of heat transfer desired via the walls 144, 146. Further, a relative rotational and linear speed of the walls 144, 146 can be adjusted to produce desired quality of the gum sheet 184, such as surface characteristics, thickness tolerance, temperature, etc. In an exemplary embodiment, the walls 144, 146 may adjustably run at linear speeds between 5m/min and 40m/min.

[00196] In one exemplary embodiment, one wall is set at a constant linear speed, while a linear speed of the other wall can be varied $\pm 30\%$ of the constant linear speed of the other wall. For example, a linear speed of the conveyor surface 144 can be set at 3 m/min to 20m/min, while a linear speed of the roller 146 is controlled between 3 m/min to 20 m/min. In such embodiment, the linear speed of the roller 146 is adjusted within the set range to achieve a smoother surface of the gum and to minimize wrinkling of the gum. Alternatively, the roller 146 may be set at a constant linear speed, while the linear speed of the conveyor surface 144 can be controlled within a desired range. A linear speed of one wall can be varied relative to a linear speed of the other wall within ranges of $\pm 40\%$, $\pm 30\%$, $\pm 20\%$, or $\pm 10\%$, depending on characteristics of a gum and a desired thickness and a width of the gum sheet 184 to maximize the smoothness and minimize wrinkles and other irregularities on the gum surface.

[00197] The dimensional configurations and material for the walls 144, 146 and support structures of the walls 144, 146 are engineered to minimize or eliminate deflection in the walls 144, 146. FIG. 5 is a schematic illustration of a cross-web view of the walls 144, 146 and structural frame 149, with the hopper 154 having been removed. As shown, the roller 146 is mounted on the structural frame 149 by a shaft 143. In this exemplary embodiment of FIG. 5, the conveyor 190 and surface 144 thereof are mounted beneath the roller 146.

[00198] As shown in FIG. 5, the walls 144, 146 are set up to provide a generally uniform cross web spacing 162 between the walls 144, 146 from one end to the other. However, some high viscosity and/or low elasticity gum compositions can impart a high stress to the walls 144, 146 as the walls 144, 146 deform the gum mass 182. Some very viscous gum structures may require additional force, such as additional augers in the hopper 154 pushing the gum mass 182 into the spacing 162 between the walls 144, 146. Such viscous gum structures can exert high stress on the walls 144, 146. Such stress can result in a deflection in the walls 144, 146 as shown in FIG. 6, wherein the deflection is exaggerated for illustration purposes. As shown, the deflection in the wall 146 can result in an uneven spacing 162 across the walls

144, 146, wherein the spacing 162 around the middle of the walls 144, 146 is greater than the spacing 162 near ends of the walls. Such uneven spacing 162 will produce a gum sheet 184 having a non-uniform cross-web thickness, which is very much undesirable as it will produce gum structure products having inconsistent dimensions.

[00199] Thus, in one embodiment, the roller 146 is strengthened by providing additional structural supports and/or supporting the roller closer to the ends of the rollers to minimize or eliminate the deflection in the rollers. In one embodiment, the roller 146 are strengthened and supported such that the maximum deflection between the walls is maintained under 0.5 mm, preferably under 0.1 mm when processing high viscosity and/or low elasticity gum structures. Further, roller deflection can also be minimized or eliminated by increasing a diameter of the roller or forming the roller from materials having increased strength or stiffness to withstand the stress imparted by the gum. For wider roller, more strength is needed to withstand the stress and a larger diameter roller can be beneficial in providing sufficient roller strength to minimize the deflection. Thus, a diameter to width ratio of the rollers is carefully selected considering physical properties of gum and desired final sheet thickness to minimize the deflection in the roller 146.

[00200] In some embodiments, wherein a viscous gum structure having a low deformability is formed via the pair of walls strengthened to minimize the deflection, a high compressive pressure can be exerted on the gum strength, which in turn applies a high stress to the walls.

[00201] Alternatively, physical properties of the gum structure can be adjusted to minimize the deflection in the walls 144, 146 during the compressive forming and sizing process. For example, a temperature of the gum structure output 130 from the mixer 102 and/or a temperature of the loaves 132 may be raised to improve compressibility of the gum mass 182 entering the pair of rollers 144, 146. In other embodiments, one or both of the walls 144, 146 may be heated to transfer heat to the gum mass 182, thereby decreasing viscosity and improving compressibility/formability. An amount of pressure and heat exerted on the gum mass 182 can have various effects on the final gum product. Thus, the deflection of the walls is controlled considering the final gum product, as strengthening of the walls can increase pressure exerted on the gum.

[00202] Another feature of the exemplary embodiment of FIG. 1 involves temperature control of conveyor surface 144 and roller 146. In some embodiments, each of the conveyor 190 and the roller 146 can be provided with internal channel(s) wherein a heating or cooling fluid such as tempered water or lower freezing point fluid flows for heating or cooling the

rollers (the conveyor surface 144 may also be supported by or upwardly adjacent to a temperature controlled plate). Therefore, the surface temperature of the walls 144, 146 may be adjusted from about -15°C to 90 °C. In one embodiment, the surface temperature of the walls 144, 146 can be controlled between about 0°C-90C° by circulating a cooling fluid or heating fluid having a temperature between about 0°C-90C° within the walls 144, 146 or adjusting the temperature of the plate disposed with the conveyor. According to one embodiment, the forming walls (particularly the conveyor surface 144 down stream of the gap 162) are chilled to a surface temperature between about 5°C to 25C°; and preferably around 15C°. This has several advantages such as potentially reducing or eliminating later conditioning/cooling, and reducing flash off of heat sensitive ingredients such as flavors as the gum is cooled much earlier in the process. In a different embodiment, the forming walls (particularly the roller 146) are heated to a surface temperature between about 40°C to 60C°, which can facilitate forming of a gum sheet and reduce thickness variation of the gum sheet. In an exemplary embodiment, it should be noted that the temperature control mechanism of the conveyor surface 144 (i.e. channels or plate) may be adjustable over a length thereof (and therefore a length of the surface 144) such that temperature of the surface 144 may vary as the gum sheet 184 moves downstream of the gap 162. For example, The conveyor surface 144 may be heated in areas proximate to the gap 162 (particularly just upstream of and within the gap 162) so as to facilitate forming, and cooled downstream of the gap 162 so as to reduce flash off and the necessity for conditioning/cooling.

[00203] In an exemplary embodiment, the finished gum mass 182 having an average temperature between about 40°C-60C° is fed between the set of forming or sizing walls 142. One or both walls 144, 146 are heated to a surface temperature between about 30°C-70C°, more preferably between about 40°C-60C° to be closely matched to the temperature of the finished gum mass 182. Such heating of the wall(s) facilitates forming of the gum and controls the viscosity of the gum, which is carried by at least the conveyor surface 144. If the surface temperature of wall(s) 144, 146 is too high, in some embodiments, the gum may heat and then become too sticky and stick to the roller(s). If the surface temperature of the wall(s) 144, 146 is too low, the local viscosity of the gum may increase to a point, wherein the gum becomes too hard for forming or may not stay on the roller 146. Thus, depending on a formulation of a finished gum, the surface temperature of the wall(s) 144, 146 may be set to aid in preventing the gum sticking to the wall(s) 144, 146, and to facilitate forming of the gum.

[00204] As is mentioned above, to achieve heating or cooling of the walls 144, 146, a heating/cooling fluid is circulated through the walls 144, 146. For example, FIG. 8 shows a cross sectional view of roller 146 including internal channel 206. In this embodiment, the internal channel 206 of the roller 146 is shown as a hollow space between an outer layer 207 and an inner core 208, wherein a plurality of rims 209 support the outer layer 207 (the plurality of rims can be designed for the maximum support, for example, the rims may be in honeycomb like arrangement). As discussed, a heating/cooling fluid can flow in the hollow space forming the channel 206 to cool the outer layer 207. In other embodiments, the cooling channel may be formed differently, for example the cooling channel can be formed of a thinner coiling channel.

[00205] Additionally, FIG. 10 schematically illustrates the chilled conveyor belt 190 including surface 144. As shown, the conveyor belt 190 includes an outer belt 230, a fluid channel 232, a plurality of spray nozzles 234, and a support or plate 236. The outer belt 230 may be formed of any suitable material such as a polymeric material. In this embodiment, the outer belt 230 is formed of a nylon. The support 236 is formed of any suitable material having a relatively high thermal conductivity, such as a metal. In this embodiment, the support 236 is formed of a stainless steel. The fluid channel 232 is configured to circulate a suitable cooling or heating fluid. In this embodiment, chilled water flows through the channel 232, wherein the plurality of spray nozzles 234 spray chilled water onto the stainless steel support 236, thereby chilling the stainless steel support 236. The chilled stainless steel support 236 supports the nylon belt 230. Therefore, when the gum sheet 184 is carried on the top surface of the conveyor belt 190, heat from the gum sheet 184 having a higher temperature than the chilled stainless steel support 236 transfers through the nylon belt 230 to the chilled stainless steel support 236, thereby cooling the gum sheet 184. In this embodiment, a thickness of the nylon belt is configured to allow an adequate heat transfer between the gum sheet 184 and the support 236, while providing a suitable support without easily tearing. In one embodiment, the support 230 has a thickness between 0.5 mm - 5 mm, and preferably between 1 mm - 2 mm.

[00206] In some embodiments, only one of the walls 144, 146 (such as the roller 146) may be provided with the temperature control mechanisms, or neither may be provided with the internal channels. The conveyor surface 144 and the roller 146 can be cooled or heated to a same temperature or different temperatures. For example, the roller 146 may not be cooled or cooled to a temperature higher than that of the conveyor surface 144. The roller 146 having a higher temperature can facilitate forming process of the gum, while the conveyor

surface 144 cooled to a lower temperature can facilitate cooling of the gum sheet 184. In one embodiment, the roller 146 is heated above a temperature of a gum mass in the hopper 154 to lower the viscosity and increase the compressibility/formability. The conveyor surface 144 is chilled to provide cooling as the gum mass 182 is compressed between the walls 144, 146. The conveyor surface 144 may also be constructed of a non-stick material.

[00207] The sheet of gum formed, sized, and cooled or heated using the walls 144, 146 can have a temperature gradient across the thickness of the gum sheet 184. This is because the gum, a substantial amount of which is elastomer, is not a good thermal conductor, and thus the middle portion of the gum may remain at a different temperature than that of surfaces, which are in direct contact with the rollers. Such a temperature gradient can be amplified when the walls 144, 146 are maintained at different temperatures. For example, in one embodiment, the roller 146 is heated to a surface temperature of about 50°C and the conveyor surface 144 is chilled to a surface temperature of about 5°C, wherein a gum mass having an average temperature of about 40°C is formed, sized and conditioned into the gum sheet 184 having a thickness of about 2 mm. In this embodiment, the gum sheet 184 can have a large temperature gradient, wherein a temperature of the gum surface in contact with the chilled conveyor surface 144 is close to the surface temperature of the conveyor surface 144 of about 5°C and a temperature of the gum surface in contact with the heated roller 146 is close to the surface temperature of the roller 146 of about 50°C with a temperature of the gum therebetween varying from about 5°C to about 50°C. In such embodiments, crystallization of the chilled gum surface can be substantially different than that of the heated gum surface, as a low temperature conduction cooling of the gum via the chilled roller can result in a very different crystallization compared to a slow cooled gum, for example by convection. Even in embodiments wherein both walls 144, 146 are chilled to a same temperature, the gum may have a temperature gradient across a thickness of the gum, although much less than that of gum formed by walls of different temperatures.

[00208] A temperature variation in an input gum mass 182 entering the gum forming station 106 can have a significant impact on the temperature consistency of the output gum sheet 184. This is because the temperature altering of the gum mass 182 by conduction via the forming wall(s) 144, 146 (particularly the roller 146, which does not maintain contact with the gum as long as the transporting conveyor surface 144) occurs in a fraction of time when compared to traditional cooling and conditioning of the gum via convection, which can be hours or even days. As such, the temperature variation in the input gum mass can translate into a temperature variation in the gum sheet that is quick cooled, for example in less than

one minute, by chilled walls(s) 144, 146. Thus, some embodiments can include measures to control a temperature variation of the input gum mass within a desired range. For example, a mixing extruder for preparing the input gum mass can be equipped with sophisticated temperature control modules to extrude the gum within the desired temperature range. In other embodiments, the gum manufacturing line 100 may include an optional conditioning unit between the loafing machine 104 and the gum forming station 106 for conditioning the gum loaves 132 to a desired temperature range.

[00209] The chilled forming walls 144, 146 can effectively reduce a temperature of the relatively thin gum sheet 184 as it is carried by the chilled forming walls(s) (particularly the transporting conveyor surface 144). Therefore, in an exemplary embodiment such as shown in FIG. 1, a distance between the gap 162 and the scoring roller 192 may be desirably extended so as to allow a longer residence time to facilitate heat transfer out of the gum sheet 184 and to the chilled roller due to contact and conduction. The speed of the conveyor surface 144 may also be reduced in order to facilitate the longer residence time. In addition, the gum mass 182 may exit the hopper 154 in a manner (for example at a height) that allows the gum to contact the roller 146 for some degree of rotation upstream of the gap 162. In such an embodiment, a relatively large diameter roller may be desirable wherein the gum mass 182 is carried over at least about $\frac{1}{4}$ a rotation (at least about 90 degrees and up to about 180 degrees) so as to further allow for a longer residence time. Again, the rotational speed of the roller 146 may also be reduced in order to facilitate the longer residence time. The chilled fluid travelling through the walls 144, 146 is excellent at maintaining the forming roller(s) to a surface temperature between about 5°C to 25°C; and preferably around 15°C. The chilled forming walls(s) having a cold metal surface having a high thermal conductivity works effectively to reduce the temperature of the relatively thin chewing gum, preferably having a thickness less than 10 mm; and more preferably at 0.5-6 mm, by facilitating heat transfer from the gum to the cold metal surface. The heat transfer may advantageously be applied by one or both of the pair of forming walls, or may also independently be a separate roller or rollers which the gum eventually contacts. In some embodiments, cooling of the gum sheet may also be assisted by an air nozzle blowing cool air onto the gum sheet.

[00210] FIG. 9 illustrates an embodiment including a stand alone cooling roller 600 (not a forming wall), wherein a continuous sheet of gum sheet 602 is guided toward the roller 600 by a guide 604. As shown, the gum sheet 602 is carried by the roller 600 about 270° around the roller for cooling. Although this embodiment is shown such that the continuous sheet of gum sheet 602 is transferred onto and off of the cooling roller 600 at 90° apart to maximize

the residence time on the cooling roller 600 (the residence time may even be longer if the angle between the entry and exit is narrowed further), the continuous sheet of gum sheet 602 may be transferred onto the cooling roller 600 at a various point and exit at a various point according to configuration of other components in a gum manufacturing system and the location of the cooling roller 600 in the gum manufacturing system. The cooling roller 600 can be arranged in various locations in a gum manufacturing system. For example, the cooling roller 600 may be arranged upstream or downstream of the forming walls 144, 146, or upstream or downstream or interposed among traditional progressive size reduction rolling rollers, etc. If downstream, the conveyor surface 144 may be configured to carry the gum to a downstream point of the cooling roller 600 as opposed to a scoring mechanism.

[00211] In some embodiments, a gum forming system may include multiple heat transfer rollers. FIG. 11 illustrates the gum forming system 700 including 3 heat transfer rollers 702, 706, 708. In this embodiment, one or both of the forming walls 702, 704 may be heated to reduce viscosity of a gum mass as the rollers 702, 704 form the gum mass to a desired width and thickness. The continuous web of gum sheet 710 exiting the conveyor surface 704 is then carried by the chilled rollers 706, 708, wherein the gum sheet is cooled to a desired temperature. In other embodiments, the pair of forming walls 702, 704 may also be chilled.

[00212] In an exemplary embodiment, the roller 146 having a diameter of about 1 meter and the conveyor surface 144 are cooled to around 15°C. The walls 144, 146 are moved to form and cool the gum mass 182 having a temperature between 40°C to 60°C at a linear speed of about 15 meters/min to provide the gum sheet 184 with a residence time on the conveyor surface of about 3/4 min. The walls 144, 146, are configured to have a spacing 162 of about 3 mm gap width to form the gum sheet 184 having a generally uniform thickness of about 3 mm, wherein the temperature of the gum will be reduced by up to 5C°. In other embodiments, the gum forming system 106 is configured to form and cool the gum at a line speed between about 5 meters/min to about 30 meters/min.

[00213] The walls 144, 146 may also provide the opportunity to eliminate dusting of the gum with talc or other particulate anti-sticking agents that are used in more conventional rolling reduction operations. This can avoid the need for dust collection equipment as used in traditional rolling and scoring lines; and can also be used to create a more aesthetically pleasing product that has more vibrant colors as dusting operations dull the final product color. Further, by eliminating the use of dusting powders, a clean up process of the gum manufacturing line 100 can be dramatically made easy, since a substantially large portion of residual mess requiring lengthy cleaning in conventional rolling and scoring lines is due to

the use of powders and the large number of rollers. As such, the clean up time for a change over, which was hours, 10 hours in some conventional rolling and scoring gum lines, can be reduced to minutes according to some embodiments of the present invention. Therefore, the embodiments of the present invention can increase the productivity of the gum manufacturing line by substantially reducing clean up/change over time when compared to traditional rolling and scoring gum lines.

[00214] In an exemplary embodiment, the walls 144, 146 may be provided with a release coating or lubricant via, for example, an oiling roller 174. The coating or lubricant may be vegetable or mineral oil that prevents sticking. Therefore, the gum forming system 106 eliminates the need of powder releasing agents such as talc or a polyol. Although each of the wall 144, 146 may be provided with the oiling roller 174, 176 as in this embodiment, in other embodiments, only one (or neither) of walls 144, 146 may be provided with an oiling roller, when one or both walls 144, 146 have a sufficiently low surface tension to release the gum sheet without aid of a releasing agent and the gum sheet is sufficiently not tacky for subsequent scoring, cutting and packaging processes. Further, other lubricating systems, for example, a spray bar or a dipping basin can be used to apply a suitable liquid lubricator.

[00215] As shown in FIG. 1, the roller 146 is provided with a scrapper 188 just downstream of the gap 162 to detach the gum sheet 184 from the surface of the roller 146 onto a conveyor belt 190.

[00216] The forming system 106 of FIG. 1 may also include a compression roller 192. Upon exiting the pair of walls 142, the conveyor surface 144 moves the gum sheet 184 toward the compression roller 192. The compression roller 192 is arranged preferably about 0.5 m to 3 m from the roller 146, more preferably about 1 m – 1.5 m. The compression roller can remove surface imperfections, kinks, and may further reduce the thickness of the gum sheet 184, however usually any further reductions can be limited to 10% or less, thereby achieving advantages in that progressive rolling reductions are not necessitated. In this embodiment, the pair of walls 142 can be configured to output the continuous sheet 184 having a thickness within 10% of a desired final thickness of the final gum product, and the compression roller 192 is configured to adjust the thickness of the gum sheet 184 by less than 10%. For example, in an implementation wherein the desired final thickness of a stick gum product is 2.0 mm, the spacing 162 of the pair of walls 142 can be adjusted such that the continuous sheet of gum sheet has a generally uniform thickness of about 2.1 mm. In this implementation, the compression roller 192 is arranged relative to the conveyor surface 144 to reduce the generally uniform thickness to about 2.0 mm.

[00217] Depending on a formulation of the gum being formed, the gum mass formed through a pair of walls may expand upon exiting the pair of walls, thereby resulting in an increased thickness of the gum sheet. For example, a gum mass may be formed through a pair of walls having a spacing of 3 mm, wherein the gum is compressed down to a thickness of about 3 mm. Upon exiting the pair of walls, the gum sheet may expand to a thickness of about 3.3 mm. In such embodiment, a subsequently arranged compression roller may be configured to apply sufficient pressure to compress the expanded gum sheet layer back down to 3 mm. In other embodiments, a gum sheet may shrink (due, for example, to gum formulation) upon exiting the pair of walls. For example, a gum sheet may shrink by about 10% in its thickness upon exit. In such embodiment, the spacing may be set to about 10% or more greater than a desired final thickness. For example, wherein the final desired thickness of the gum sheet thickness is 3 mm, the pair of walls can be set to have a spacing of about 3.5 mm. The gum sheet is compressed down to a thickness of about 3.5 mm between the pair of walls and shrinks upon exiting the pair of walls to a thickness between about 3.1 mm – 3.2 mm. The shrunken gum sheet is then further compressed via a subsequent compression roller to the desired final thickness of about 3 mm. In some embodiments, the compression roller 192 can be configured to be a chilled roller to provide additional cooling.

[00218] In the exemplary embodiment of FIG. 1 the system 100 further includes a scoring roller 194, a lateral dividing roller 196 downstream of the compression roller 192, and a cooling tunnel 200. The scoring roller 194 and the lateral dividing roller 196 score and divide the gum sheet 184 into individual scored sheets 198. The scored sheets 198 are conveyed to the cooling tunnel 200, wherein the scored sheets 198 are cooled from both top and bottom sides with a forced air. As the scored sheets 198 are further conditioned in the cooling tunnel 200, the gum material of the scored sheets 198 stiffens sufficient enough for stacking so as to maintain shape and to minimize material creep. In one embodiment, the cooling tunnel 200 is configured to condition the gum sheet 184 to a temperature as low as about 0°C-15°C. The scored sheet 184 is then cut and stacked into stacks of gum sheets 202 and transferred for subsequent packaging processes. In other embodiments, the cooling tunnel 200 can be arranged at different locations in the gum manufacturing system 100. For example, the cooling tunnel 200 can be arranged between the compression roller 192 and the scoring roller 194, such that the gum is cooled before being scored and/or cut. Alternatively, the gum manufacturing system 100 may include additional dividing and/or cutting rollers and packaging equipments for producing packaged gum products in a single line.

[00219] The cooling tunnel 200 can be of any conventional type, for example, the cooling chamber disclosed in U.S. Patent No. 6,214,389 assigned to the predecessor of interest of the present assignee, the teachings and disclosures of which are hereby incorporated by reference in its entirety to the extent not inconsistent with the present disclosure. The cooling tunnel 200 may also be similar to the cooling towers disclosed in U.S. Patent No. 5,756,133 assigned to the predecessor of interest of the present assignee, the teachings and disclosures of which are hereby incorporated by reference in its entirety to the extent not inconsistent with the present disclosure. The cooling tunnel 200 may utilize a forced air cooling mechanism and/or liquid cooled parts such as chilled rollers, chilled belts, chilled steel bands, etc. Further, the cooling tunnel 200 may be compartmentalized including different chambers or areas having different internal temperatures and/or humidity, for example, via force air input of different temperatures and/or humidity.

[00220] In some embodiments, the scoring roller 194 and the dividing roller 196 may be replaced with other gum shaping solutions, such as a drop-roller, a die cutter, pelletizer or other similar gum shaping equipments (provided the sheet is cooled to a sufficient extent). As such, the gum manufacturing system 100 can produce a chewing gum having various final shapes, such as slabs which can subsequently be packaged, or pellets that are subsequently coated.

[00221] In one embodiment, the scoring roller 194 and the dividing roller 196 are replaced with a rolling/scoring system such as the traditional rolling and scoring systems disclosed in U.S. Patent Nos. 4,882,175 and 7,112,345, the teachings and disclosures of which are hereby incorporated by reference in their entireties to the extent not inconsistent with the present disclosure. The cooling tunnel 200 may be arranged before or after final gum shaping equipment or a rolling/scoring system.

[00222] In one embodiment, the scoring roller 194 and the dividing roller 196 are replaced with a traditional rolling/scoring system with the rolling/sizing rollers omitted because the forming/sizing of the gum is completed via the gum forming system 106. The cooling tunnel 200 is arranged after the rolling/scoring system. In this embodiment, a finished gum 182 in the hopper 154 has an average temperature between 40°C-60°C. The walls 144, 146 are equipped with temperature control mechanisms, wherein a heating/cooling fluid may be circulated to heat the walls 144, 146. In an exemplary embodiment, the fluid temperature is controlled to maintain the walls 144, 146 at a surface temperature between 40°C-60°C. Presumably, the temperature of the fluid is correspondingly between 40°C-60°C. The walls 144, 146 facilitate forming of a continuous gum sheet 184 and controls a local viscosity of

the gum such that the gum can be formed to a desired thickness and width and carried by the conveyor surface 144 (downstream of the gap 162). The gum sheet 184 exiting the set of walls 144, 146 has a temperature at the surface in contact with the conveyor surface 144 between 35°C-60°C and at the surface not in contact with the conveyor surface 144 between 35°C-60°C. Depending on a thickness and formulation of the continuous gum sheet 184, a temperature gradient throughout the thickness of the gum may be between plus or minus 0°C-5°C. The continuous sheet of gum having a temperature between 35°C-60°C then enters the rolling/scoring system, wherein the continuous sheet of gum is scored and/or cut to sheets, ropes, strips, pellets, etc. The scored gum having a temperature between 20°C-30°C and a temperature gradient throughout the thickness of between plus or minus 0°C-5°C enters the cooling tunnel 200.

[00223] The internal temperature of the cooling tunnel 200 is maintained at a temperature between 0°C-25°C, wherein forced air having a temperature between 0°C-25°C and/or other chilled rollers, belts, steel bands, etc. having a temperature between 0°C-25°C are utilized. An internal humidity level of the cooling tunnel 200 is maintained at between 30% RH – 50% RH. A residence time of the gum in the cooling tunnel may be between 30 seconds – 10 minutes, depending on the desired temperature of the gum and/or downstream final shaping/packaging processes as well as gum handling capabilities of the cooling tunnel 200 and the form of the gum as it passes through the cooling tunnel 200. The gum exiting the cooling tunnel 200 has a temperature between 5°C-20°C and a temperature gradient throughout the thickness of gum of between having a temperature between 0°C-1°C. In one embodiment, the continuous sheet of gum is scored into pellets and cooled via the cooling tunnel 200, wherein the cooled sheet is hard enough to be dropped into a bin to break apart.

[00224] Although, the gum manufacturing system 100 includes the cooling tunnel 200, the cooling tunnel 200 is optional. In other embodiments, the pair of walls 142 equipped with cooling mechanisms may sufficiently lower the temperature of the gum sheet 184 such that further conditioning may not be necessary. Further, as discussed above, the gum forming system including cooled wall(s) and optional cooling tunnel provide sufficient cooling and conditioning of the gum product, and a subsequent conditioning of a conditioning room prior to packaging is not necessary for some gum formulations. The elimination of a lengthy conditioning in the conditioning room can substantially reduce flash off of volatile gum ingredients such as flavors, thereby preserving more flavors for consumer enjoyment. Further, by eliminating the use of the forming extruder, the gum forming system 106 may

reduce the amount of shear and mechanical force applied to the gum product, thereby better preserving shear sensitive gum ingredients such as encapsulated flavors and sweeteners.

[00225] Although the mixing system 102 of FIG. 1 is shown as a continuous line including the gum mixing system 102, the loafing machine 104, and the gum forming system 106, in other embodiments, one or more of these components of the gum manufacturing system 100 may be located in different parts of a manufacturing plant or even in a different manufacturing plant. For example, in one embodiment, the gum mixing system 102 and the loafing machine 104 are located in one plant, and the gum forming system 106 and other subsequent components, such as the scoring and dividing rollers 194, 196 and packaging components, are located in a different plant, wherein the gum loaves 132 formed by the loafing machine 104 are transferred from one plant to the other for subsequent processes.

[00226] OTHER ILLUSTRATED EMBODIMENTS

[00227] As mentioned during the above discussion regarding the first embodiment, there are numerous other embodiments of a gum manufacturing system including a gum forming system such as 106, some of which will be introduced below. These other embodiments will be explained in much less detail with reference to the components of the first embodiment for details. It is understood that the options, description and discussion above for forming system 106 and overall system 100 are also applicable in the below described embodiments.

[00228] A gum manufacturing system 300 shown in FIG. 2 includes a mixing system 302, a forming or sizing system 306, a compression roller 308, a scoring roller, 310, a cooling tunnel 312 and a packaging station 314. In this embodiment, the gum manufacturing system 300 preferably produces a finished gum, although other gum compositions may also be processed in the system 300. The mixing system 302 may include one or more mixers, as it was with the mixing system 102, however, the mixing system 302 is shown here as an extruder configured to output a non-uniform finished gum mass 304. The non-uniform finished gum mass 304 is then fed directly into the forming system 306, without being preformed into a uniform shape. The finished gum mass 304 is sized and cooled by the walls 142 of the forming system 306 as described at length with regard to the forming system 306. The finished gum is subsequently processed through the compression roller 308 and the scoring roller 310 as it was with the first embodiment of FIG. 1. In this embodiment, the scoring roller 310 is configured to trim the edges of the continuous web of the finished gum, wherein the trimmed edges are recycled back into the forming system 106 to reduce or eliminated waste. The scored web of finished gum may optionally be further conditioned to a desired temperature and a moisture content in the cooling tunnel 312 prior to entering the

packaging station 314, wherein the scored web of finished gum is further divided and wrapped into a final gum product 316.

[00229] The gum manufacturing system 300 provides a continuous line from mixing of gum ingredients to packaging of a final gum product. As such, any delays from staging and/or transportation of work-in-process products are substantially reduced or eliminated. Further, the walls of the forming system 306 and the cooling tunnel 312 provide sufficient cooling and conditioning such that the finished gum can be immediately packaged without being conditioned in a conditioning room for a relatively long period of time. Such continuous system for manufacturing and packaging of gum products without a lengthy conditioning is specially beneficial for retaining volatile ingredients such as flavors by reducing flash off.

[00230] FIG. 3 shows another embodiment of a gum manufacturing system. The gum manufacturing system 400 includes a mixing system 402, a pre-forming extruder 404, a forming or sizing system 408, scoring roller 420, and a dividing roller 422. The mixing system 402 of this embodiment is a batch mixer which outputs a non-uniform gum mass. The non-uniform gum mass is then fed into the low shear pre-forming extruder 404 including a large output orifice to minimize any shear stress introduced in the gum as it is being formed into a generally uniform continuous web of gum structure 406 having a thickness greater than about 20 mm (in other similar embodiments, the thickness of the web of gum structure may be less or greater than 20 mm.) The continuous web of the gum structure 406 is fed as gum mass 407 into a hopper 412, wherein a slanted wall 410 of the hopper 412 guides the accumulating gum mass 407 toward walls 414, 418, wherein the walls 414, 418 size and cool the gum mass 407 into a gum sheet 416 of a desired thickness and a temperature. The hopper 412 can provide surge control and feed control functions, and may also allow for slacks gum mass 407 which can be controlled for a consistent feed into the walls 414,418. The gum sheet 416 is subsequently scored and divided via the scoring roller 420 and the dividing roller 422. The scored and divided gum is then stacked into a stack 424 for further downstream processes as it was with the first embodiment of FIG. 1 (provided the structure has been cooled and/or dusted).

[00231] The gum manufacturing system 400 provides a mechanism for continuous feeding of a generally uniform web of the chewing gum into the forming system 408. Such system can be advantageous for producing a gum sheet 416 having a consistent web width and may further reduce force required for sizing of the gum since the uniform feed can be easier to compress through a spacing between the rollers than an inconsistent non-uniform gum mass.

[00232] FIG. 4 shows yet another embodiment of a gum manufacturing system. The gum manufacturing system 500 includes a mixing system 502, a pre-forming extruder 504, a forming or sizing system 508, an applicator 512, a compression roller 514, a scoring roller 516, and a dividing roller 518. In this embodiment, the gum manufacturing system 500 preferably produces a finished gum including other confectionery articles sprinkled and embedded on the top surface. The mixing system 502 of this embodiment is shown as an extruder outputting a non-uniform finished gum mass. The non-uniform finished gum mass is then fed into a low shear pre-forming extruder 504 wherein the non-uniform finished gum mass is formed into a generally uniform continuous web of finished gum 506, as it was with the embodiment of FIG. 3. The continuous web of finished gum is then sized and cooled in the forming system 508, as described with regard to the forming system 408. The web of finished gum 510 (or the roller 146) exiting the forming system 508 is sprinkled with confectionery chips, candy sprinkles or other confectionery materials using the applicator 512. Although shown here as a single applicator, two or more applicators can be provided for sprinkling of more than one confectionary materials. In other embodiments, the web of finished gum 510 may be printed with edible materials at this point. The web of finished gum 510 sprinkled with confectionary materials passes through the compression roller 514, wherein sprinkled confectionary materials are embedded into the top surface of the finished gum as the compression roller 514 smoothes the surface of the sprinkled web of finished gum. The web of sprinkled finished gum is then scored and divided using the scoring roller 516 and the dividing roller 518, and stacked into a stack 520 for further downstream processes, as it was with the embodiment of FIG. 1.

[00233] The gum manufacturing system 500 allows for production of various gum products including different edible pieces embedded on the surface of the chewing gum. As such, a finished gum formulation can be used to manufacture, for example, various chewing gum products having different flavored candy sprinkles.

[00234] Referring to the exemplary embodiment of FIG. 12, a system 800 wherein the moving walls 802 are both conveyors 804 and 806 is shown. Though these conveyors 804 and 806 are shown to include a specific shape, any desirable shape (such as that shown in Figure 1) may be employed for one or both walls 802. These walls may be actuated (at various speeds) and temperature controlled via any desirable means, such as those discussed with reference to system 106.

[00235] SPECIFIC GUM FORMING EXAMPLES

[00236] In laboratory system, a separate motor drives each of the walls. A gap between the upper and lower forming walls, is adjusted via a servo system. Any roller used in the may formed of a highly polished stainless steel. The roller has a diameter of about 650mm. The roller and conveyor have a same width, slightly great than about 230mm, which can form a 9 inch (228.6mm) wide sheet of gum. Each wall is configured to circulate a cooling or heating fluid, or impart temperature change to the gum.

[00237] The compression roller is arranged on the conveyor belt. A gap between the compression roller and the conveyor belt is manually adjusted to match a thickness of a gum sheet formed via the upper and lower forming rollers. The compression roller is also formed of a highly polished stainless steel. The compression roller has a diameter of about 464mm and a width slightly greater than about 230mm to process up to a 9inch wide gum sheet. The compression roller is also configured as a heat exchange roller with internal channels to circulate a cooling or heating fluid.

[00238] In these laboratory runs, a desired finished gum is prepared upstream into a rope, and the rope of finished gum is fed into the hopper. However, the gum can be fed continuously in a generally uniform web or fed in batches in irregular chunks. In the laboratory system, the rope of finished gum fed into the hopper has a temperature between about 45°C and 55°C, and a viscosity of about 1,000,000 cP \pm 10%.

[00239] In the laboratory system, the forming walls are driven independently by the motors. Thus, the walls can be configured for linear speed at the gap of a same or a different linear speed. Each of the forming walls can move at a linear speed between about 1-40m/min, preferably between about 3-35m/min, and more preferably between about 5-16m/min. The compression roller can rotate at a same or different linear speed than the forming walls. The compression roller can have a linear speed between 1-40m/min, preferably between about 3-35m/min, and more preferably between about 5-16m/min.

[00240] In the laboratory system, the walls are configured to have a same surface temperature between about 5°C and 90°C, preferably between about 15°C and 70°C, and more preferably between about 45°C and 60°C. The compression roller can have a same or different surface temperature than the walls. The compression roller can have a surface temperature between about 5°C and 50°C, preferably between about 10°C and 40°C, and more preferably between about 14°C and 22°C.

[00241] Finish gum sheets having various thicknesses between about 1mm and 6mm were formed using the laboratory system. The thickness and the thickness variance were

optimized by adjusting a temperature of the forming walls, a linear speed of the walls, a temperature of the compression roller, a gap between the walls. Exemplary gum forming run results are summarized in Table 2.

[00242] Table 2

Input Variable					Output Data		
Temp. (°C) of at least one of the forming walls	Upper forming wall speed (m/min)	Lower forming wall speed (m/min)	Compression roller temp. (°C)	Gap between upper and lower wall (mm)	Mean thickness of gum sheet (mm)	Std. Dev. (mm)	CV (%)
60	16	16	40	1.50	1.409	0.147	10.431
50	10.5	10.5	25	1.50	1.625	0.209	12.877
60	5.0	5.0	10	1.50	1.313	0.116	8.822
60	5.0	5.0	40	1.50	1.171	0.113	9.629
60	10.5	10.5	25	3.25	2.926	0.183	6.258
50	10.5	10.5	25	3.25	3.098	0.169	5.448
40	16.0	16.0	10	5.50	5.69	0.305	5.361
50	10.5	10.5	40	3.25	5.16	0.160	3.102
60	16	16	40	5.50	5.593	0.189	3.378
60	16.0	16.0	10	5.50	5.645	0.196	3.474
50	10.5	10.5	10	3.25	3.166	0.159	5.023

40	5	5	10	5.50	5.527	0.172	3.019
50	10.5	10.5	25	5.50	5.707	0.181	3.174
40	10.5	10.5	25	3.25	3.545	0.170	4.783
60	5.0	16.0	40	4.00	2.864	0.249	8.683
40	5.0	16.0	40	1.50	1.046	0.118	11.272
40	5.0	16.0	10	4.00	3.252	0.420	12.921
60	5.0	8.67	10	5.50	4.996	0.322	6.449

[00243] All references, including publications, patent applications, and patents cited herein are hereby incorporated by reference to the same extent as if each reference were individually and specifically indicated to be incorporated by reference and were set forth in its entirety herein.

[00244] The use of the terms “a” and “an” and “the” and similar referents in the context of describing the invention (especially in the context of the following claims) is to be construed to cover both the singular and the plural, unless otherwise indicated herein or clearly contradicted by context. The terms “comprising,” “having,” “including,” and “containing” are to be construed as open-ended terms (i.e., meaning “including, but not limited to,”) unless otherwise noted. Recitation of ranges of values herein are merely intended to serve as a shorthand method of referring individually to each separate value falling within the range, unless otherwise indicated herein, and each separate value is incorporated into the specification as if it were individually recited herein. All methods described herein can be performed in any suitable order unless otherwise indicated herein or otherwise clearly contradicted by context. The use of any and all examples, or exemplary language (e.g., “such as”) provided herein, is intended merely to better illuminate the invention and does not pose a limitation on the scope of the invention unless otherwise claimed. No language in the specification should be construed as indicating any non-claimed element as essential to the practice of the invention.

[00245] Preferred embodiments of this invention are described herein, including the best mode known to the inventors for carrying out the invention. Variations of those preferred embodiments may become apparent to those of ordinary skill in the art upon reading the foregoing description. The inventors expect skilled artisans to employ such variations as appropriate, and the inventors intend for the invention to be practiced otherwise than as specifically described herein. Accordingly, this invention includes all modifications and equivalents of the subject matter recited in the claims appended hereto as permitted by applicable law. Moreover, any combination of the above-described elements in all possible variations thereof is encompassed by the invention unless otherwise indicated herein or otherwise clearly contradicted by context.

WHAT IS CLAIMED IS:

1. A method of forming gum, the method comprising:
providing a pair of moving walls including a first wall and a second wall; and
sizing a gum mass into a gum sheet having a substantially uniform thickness between about 0.3 mm to 10 mm using said pair of walls, said gum mass maintaining substantially continuous contact with at least one of said walls before and after said sizing.

2. The method of claim 1, wherein said gum mass maintains said substantially continuous contact with at least one of said walls beyond a downstream extent of at least one of said walls.

3. The method of claim 1, wherein said first wall is a roller and said second wall is a conveyor belt.

4. The method of claim 1, wherein said mixed gum mass is in a form of a non-uniform gum mass; wherein sizing includes driving said pair of walls in a same direction at an area of said sizing to pull said non-uniform gum mass through a gap between said pair of walls, and deforming said non-uniform gum mass to form said sheet of gum.

5. The method of claim 4, wherein said deforming includes applying an even cross web compressive force on said non-uniform gum mass to form said sheet of gum having a cross web thickness variance less than 10% and a width greater than about 0.6 meters.

6. The method of claim 1, further comprising removing any irregularities on a surface of said sheet of gum using a roller downstream of said walls; wherein said removing further reduces said thickness of said sheet of gum by less than 10%.

7. The method of claim 1, wherein said thickness of said sheet of gum expands by less than 10% after a compressive force applied using said pair of walls is removed upon exiting said pair of walls; and further comprising compressing said expanded sheet of gum using a roller downstream of said walls and reducing said thickness by less than 10%.

8. The method of claim 1, further comprising sprinkling said sheet of gum with a confectionery material and compressing said sprinkled sheet of gum, thereby embedding said confectionery material into said sheet of gum and smoothing out a surface of said sheet of gum.

9. The method of claim 1, wherein said gum mass includes shear sensitive ingredients including encapsulated flavors and/or sweeteners, wherein sizing using said pair of walls preserves said shear sensitive ingredients by minimizing a shear force applied to said gum mass.

10. The method of claim 1, further comprising pre-forming said gum mass from said mixer into a generally uniform shape, wherein pre-forming includes shaping said gum mass into loaves of gum mass having a thickness between about 13 mm and 50 mm and a length and a width between about 0.15 m and 0.46 m using a low shear extruder.

11. The method of claim 1, further comprising feeding said non-uniform gum mass into a hopper including a pair of feeding rollers, conveying said non-uniform gum mass using said feeding rollers and spreading said non-uniform gum mass to a width approximately corresponding to a width of said feeding rollers and directing said non-uniform gum mass to said pair of walls.

12. The method of claim 1, further comprising pre-forming said gum mass from said mixer into a continuous web of gum mass having a generally uniform thickness of greater than about 20 mm using a low shear extruder having a large output orifice to minimize shear force applied on said gum mass in said extruder; wherein said sizing includes forming said continuous web of gum mass by applying a compressive force and reducing said thickness of said continuous web of gum mass to a thickness between about 2 mm – 6 mm, thereby forming said sheet.

13. The method of claim 1, further including setting up said pair of walls, the setting up comprising:

arranging said first wall vertically above said second wall, wherein a gum inlet region is provided upstream of said wall;

providing a spacing between said first and second walls corresponding to a desired thickness of continuous sheet of gum sheet;

powering said pair of walls using at least one motor having an energy input of less than about 5 horsepower; and

moving said first wall and said second wall in a same direction to convey said gum mass in said gum inlet region toward said spacing between said pair of rollers.

14. The method of claim 1, wherein sizing produces said continuous gum sheet having a width between 0.6 m and 1.2 m and a thickness between 2 mm and 6 mm.

15. The method of claim 1, further including lubricating said sheet of gum with a liquid lubricator, thereby producing said sheet of gum free of powder dusting material.

16. The method of claim 15, wherein lubricating includes applying a liquid lubricator on at least one of said walls.

17. The method of claim 1, further comprising heating said gum mass by heating at least one of first and second walls to lower a viscosity of said gum mass and increase a deformability of said gum mass during said sizing.

18. The method of claim 1, further comprising cooling said sheet of gum using a roller downstream of said pair of walls, wherein said roller downstream of said pair of walls is chilled.

19. The method of claim 1, wherein said sizing includes running said first wall and said second wall at different linear speeds.

20. The method of claim 1, wherein said first wall is running at a constant linear speed and said second wall is running at a linear speed between $\pm 30\%$ of said constant linear speed of said first wall.

21. The method of claim 1, further including structuring said first wall and said second wall to maintain a maximum deflection between said walls under 0.5 mm during said sizing.

22. The method of claim 1, further comprising changing a temperature of said gum mass by at least 5C° using at least one of said first wall and said second wall.

23. The method of claim 22, wherein said changing a temperature includes heating said gum mass by heating at least one of first and second walls, wherein said heating said gum mass lowers a viscosity of said gum mass and increases a deformability of said gum mass during said sizing.

24. The method of claim 1, wherein said sizing includes regulating at least one of said pair of walls to a temperature between -5°C and 60°C.

25. The method of claim 6, further including maintaining said roller downstream of said pair of walls at a temperature between 10°C and 40°C.

26. The method of claim 1, further including heating at least one of said walls to a surface temperature between about 40°C and 60°C; wherein an average temperature of said gum mass entering said pair of walls is between about 40°C and 60°C; wherein said heating of said at least one wall facilitates said sizing of said gum mass; wherein said gum sheet exiting said pair of walls has a temperature between 35°C and 60°C.

27. The method of claim 1, wherein at least one of said pair of walls move at 50% to 150% of a speed of said sheet as said sheet exits said walls.

28. The method of claim 1, wherein a linear speed of said walls at an area of said sizing is 5m/min to 40m/min.

29. The method of claim 1, wherein at least one of said walls is a roller including a diameter of 250mm to 1000mm.

30. A method of forming gum, the method comprising:
providing a pair of moving walls including a first wall and a second wall; and
sizing a gum mass into a gum sheet having a substantially uniform thickness between about 0.3 mm to 10 mm using said pair of walls, at least one of said walls including a substantially planar surface.

31. The method of claim 30, wherein said first wall includes said substantially planar surface and said second wall includes a substantially circular surface.

32. The method of claim 30, wherein said first wall is a roller and said second wall is a conveyor belt.

33. The method of claim 30, wherein said gum mass is in a form of a non-uniform gum mass; wherein sizing includes driving said pair of walls in a same direction at an area of said sizing to pull said non-uniform gum mass through a gap between said pair of walls, and compressing said non-uniform gum mass to form said sheet of gum.

34. The method of claim 33, wherein compressing includes applying an even cross web compressive force on said non-uniform gum mass to form said sheet of gum having a cross web thickness variance less than 10% and a width greater than about 0.6 meters.

35. The method of claim 30, further comprising removing any irregularities on a surface of said sheet of gum using a roller downstream of said walls; wherein said removing further reduces said thickness of said sheet of gum by less than 10%.

36. The method of claim 30, wherein said thickness of said sheet of gum expands by less than 10% after a compressive force applied using said pair of walls is removed upon exiting said pair of walls; and further comprising compressing said expanded sheet of gum using a roller downstream of said walls and reducing said thickness by less than 10%.

37. The method of claim 30, further comprising sprinkling said sheet of gum with a confectionery material and compressing said sprinkled sheet of gum, thereby embedding said confectionery material into said sheet of gum and smoothing out a surface of said sheet of gum.

38. The method of claim 30, wherein said gum mass includes shear sensitive ingredients including encapsulated flavors and/or sweeteners, wherein sizing using said pair of walls preserves said shear sensitive ingredients by minimizing a shear force applied to said gum mass.

39. The method of claim 30, further comprising pre-forming said gum mass from said mixer into a generally uniform shape, wherein pre-forming includes shaping said gum mass into loaves of gum mass having a thickness between about 13 mm and 50 mm and a length and a width between about 0.15 m and 0.46 m using a low shear extruder.

40. The method of claim 30, further comprising feeding said non-uniform gum mass into a hopper including a pair of feeding rollers, conveying said non-uniform gum mass using said feeding rollers and spreading said non-uniform gum mass to a width approximately corresponding to a width of said feeding rollers and directing said non-uniform gum mass to said pair of walls.

41. The method of claim 30, further comprising pre-forming said gum mass from a mixer into a continuous web of gum mass having a generally uniform thickness of greater than about 20 mm using a low shear extruder having a large output orifice to minimize shear force applied on said gum mass in said extruder; wherein said sizing includes forming said continuous web of gum mass by applying a compressive force and reducing said thickness of said continuous web of gum mass to a thickness between about 2 mm – 6 mm, thereby forming said sheet.

42. The method of claim 30, further including setting up said pair of walls, the setting up comprising:

arranging said first wall vertically above said second wall, wherein a gum inlet region is provided upstream of said walls;

providing a spacing between said first and second walls corresponding to a desired thickness of continuous sheet of gum sheet;

powering at least one of said pair of walls using a motor having an energy input of less than about 5 horsepower; and

moving said first wall and said second wall in a same direction to convey said gum mass in said gum inlet region toward said spacing between said pair of rollers.

43. The method of claim 30, wherein sizing produces said continuous sheet of gum mass having a width between 0.6 m and 1.2 m and a thickness between 2 mm and 6 mm.

44. The method of claim 30, further including lubricating said sheet of gum with a liquid lubricator, thereby producing said sheet of gum free of powder dusting material.

45. The method of claim 44, wherein lubricating includes applying a liquid lubricator on at least one of said walls.

46. The method of claim 30, further comprising heating said gum mass by heating at least one of first and second walls to lower a viscosity of said gum mass and increase a deformability of said gum mass during said sizing.

47. The method of claim 30, further comprising cooling said sheet of gum using a roller downstream of said pair of walls, wherein said roller downstream of said pair of walls is chilled.

48. The method of claim 30, wherein said sizing includes running said first wall and said second wall at different linear speeds.

49. The method of claim 30, wherein said first wall is running at a constant linear speed and said second wall is running at a linear speed between $\pm 30\%$ of said constant linear speed of said first wall.

50. The method of claim 30, further including structuring said first wall and said second wall to maintain a maximum deflection between said walls under 0.5 mm during said sizing.

51. The method of claim 30, further comprising changing a temperature of said gum mass by at least 5°C using at least one of said first wall and said second wall.

52. The method of claim 51, wherein said changing a temperature includes heating said gum mass by heating at least one of first and second walls, wherein said heating said gum mass lowers a viscosity of said gum mass and increases a deformability of said gum mass during said sizing.

53. The method of claim 30, wherein said sizing includes regulating at least one of said pair of walls to a temperature between -5°C and 60°C.

54. The method of claim 35, wherein said removing includes maintaining said roller downstream of said pair of walls at a temperature between 10°C and 40°C.

55. The method of claim 30, further including heating at least one of said walls to a surface temperature between about 40°C and 60°C; wherein an average temperature of said gum mass entering said pair of walls is between about 40°C and 60°C; wherein said heating of said at least one wall facilitates said sizing of said gum mass; wherein said sheet of gum exiting said pair of walls has a temperature between 35°C and 60°C.

56. The method of claim 30, wherein said pair of walls move at 50% to 150% of a speed of said sheet as said sheet exits said walls.

57. The method of claim 30, wherein a linear speed of said walls at an area of said sizing is 5m/min to 40m/min.

58. The method of claim 30, wherein at least one of said walls is a roller including a diameter of 250mm to 1000mm.

59. A system of forming gum, the system comprising:
a gum inlet configured to provide a gum mass to the system;
a pair of moving walls downstream of said inlet, said pair of moving walls including a first wall and a second wall; and
a gap between said first and second walls, said gap being configured to size the gum mass into a gum sheet including a width of substantially 0.3 mm to 10 mm, at least one of said walls being configured for substantially continuous and transporting contact with the gum sheet upstream and downstream of said gap.

60. The system of claim 59, wherein at least one of said walls is configured for substantially continuous and transporting contact with the gum sheet from said inlet to at least one of a scoring device and a roller downstream of said walls.

61. A system of forming gum, the system comprising:
a gum inlet configured to provide a gum mass to the system;
a pair of moving walls downstream of said inlet, said pair of moving walls including a first wall and a second wall; and
a gap between said first and second walls, said gap being configured to size the gum mass into a gum sheet including a width of substantially 0.3 mm to 10 mm, at least one of said walls including a substantially planar surface.

62. The method of claim 61, wherein said first wall includes said substantially planar surface and said second wall includes a substantially circular surface.

63. A method of forming gum, the method comprising:
providing a pair of moving walls including a first wall and a second wall; and
sizing a gum mass into a gum sheet having a substantially uniform thickness between about 0.3 mm to 10 mm using said pair of walls, the gum mass being substantially unshaped immediately prior to said sizing.

64. A system of forming gum, the system comprising:
a gum inlet configured to provide a gum mass to the system;
a pair of moving walls downstream of said inlet, said pair of moving walls including a first wall and a second wall; and
a gap between said first and second walls, said gap being configured to size the gum mass into a gum sheet including a width of substantially 0.3 mm to 10 mm, the inlet being

configured to provide the gum mass in a substantially unshaped form immediately upstream of said gap.

65. The method of claim 1, wherein the gum mass has a thickness dimension of at least 10 times said gum sheet.

66. The method of claim 30, wherein the gum mass has a thickness dimension of at least 10 times said gum sheet.

67. The method of claim 63, wherein the gum mass has a thickness dimension of at least 10 times said gum sheet.

68. The method of claim 1, wherein said gum mass is accumulated immediately prior to said sizing via said pair of walls.

69. The method of claim 30, wherein said gum mass is accumulated immediately prior to said sizing via said pair of walls.

70. The method of claim 63, wherein said gum mass is accumulated immediately prior to said sizing via said pair of walls.

71. A method of forming confectionary, the method comprising:
providing a pair of moving walls including a first wall and a second wall; and
sizing a confectionary mass into a confectionary sheet having a substantially uniform thickness between about 0.3 mm to 10 mm using said pair of walls, said confectionary mass maintaining substantially continuous contact with at least one of said walls before and after said sizing.

72. A method of forming confectionary, the method comprising:
providing a pair of moving walls including a first wall and a second wall; and
sizing a confectionary mass into a confectionary sheet having a substantially uniform thickness between about 0.3 mm to 10 mm using said pair of walls, at least one of said walls including a substantially planar surface.

73. A system of forming confectionary, the system comprising:
a confectionary inlet configured to provide a confectionary mass to the system;
a pair of moving walls downstream of said inlet, said pair of moving walls including a first wall and a second wall; and
a gap between said first and second walls, said gap being configured to size the confectionary mass into a confectionary sheet including a width of substantially 0.3 mm to 10 mm, at least one of said walls being configured for substantially continuous and transporting contact with the confectionary sheet upstream and downstream of said gap.

74. A system of forming confectionary, the system comprising:

a confectionary inlet configured to provide a confectionary mass to the system;
a pair of moving walls downstream of said inlet, said pair of moving walls including a first wall and a second wall; and

a gap between said first and second walls, said gap being configured to size the confectionary mass into a confectionary sheet including a width of substantially 0.3 mm to 10 mm, at least one of said walls including a substantially planar surface.

75. A method of forming confectionary, the method comprising:
providing a pair of moving walls including a first wall and a second wall; and
sizing a confectionary mass into a confectionary sheet having a substantially uniform thickness between about 0.3 mm to 10 mm using said pair of walls, the confectionary mass being substantially unshaped immediately prior to said sizing.

76. A system of forming confectionary, the system comprising:
a confectionary inlet configured to provide a confectionary mass to the system;
a pair of moving walls downstream of said inlet, said pair of moving walls including a first wall and a second wall; and

a gap between said first and second walls, said gap being configured to size the confectionary mass into a confectionary sheet including a width of substantially 0.3 mm to 10 mm, the inlet being configured to provide the confectionary mass in a substantially unshaped form immediately upstream of said gap.

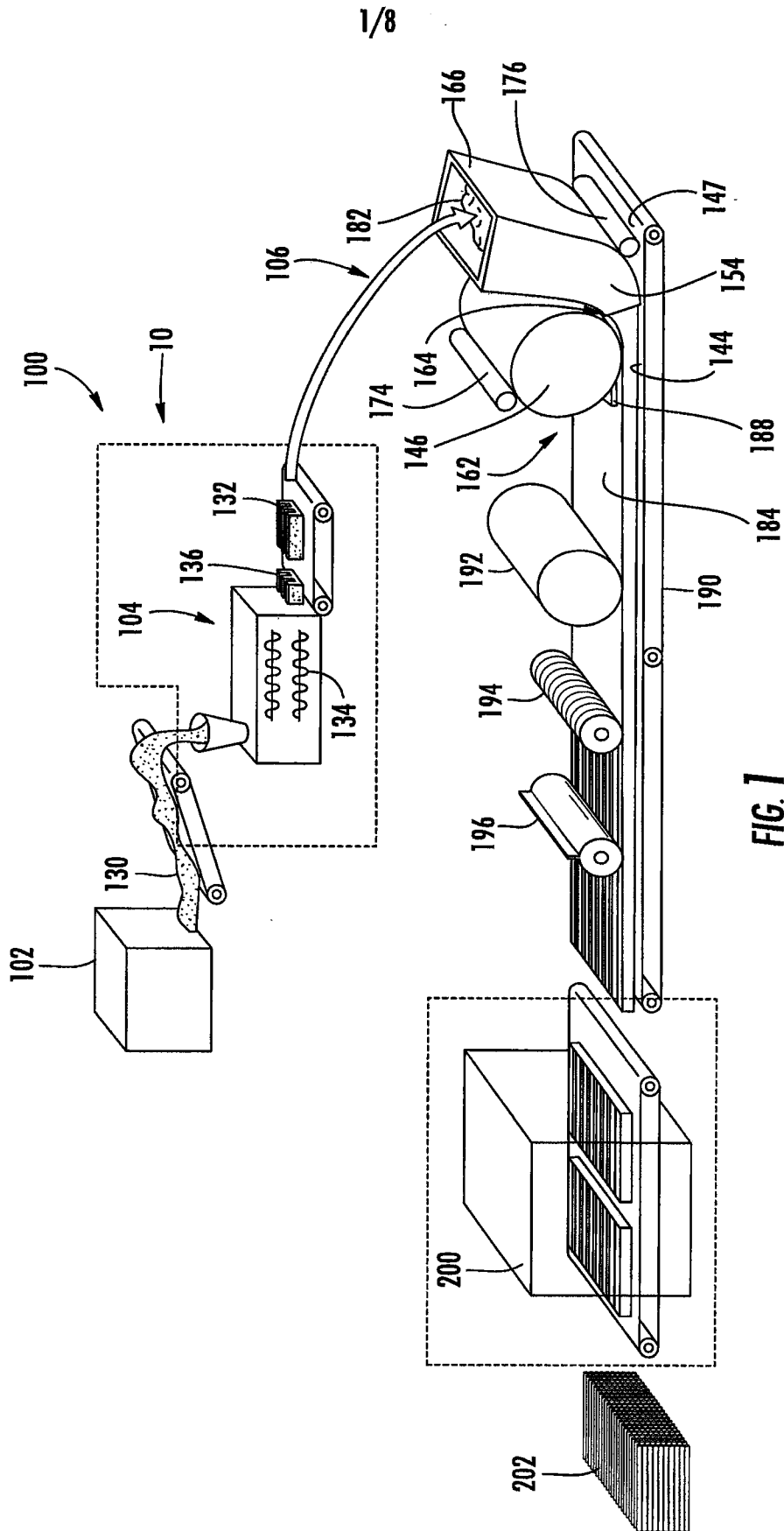

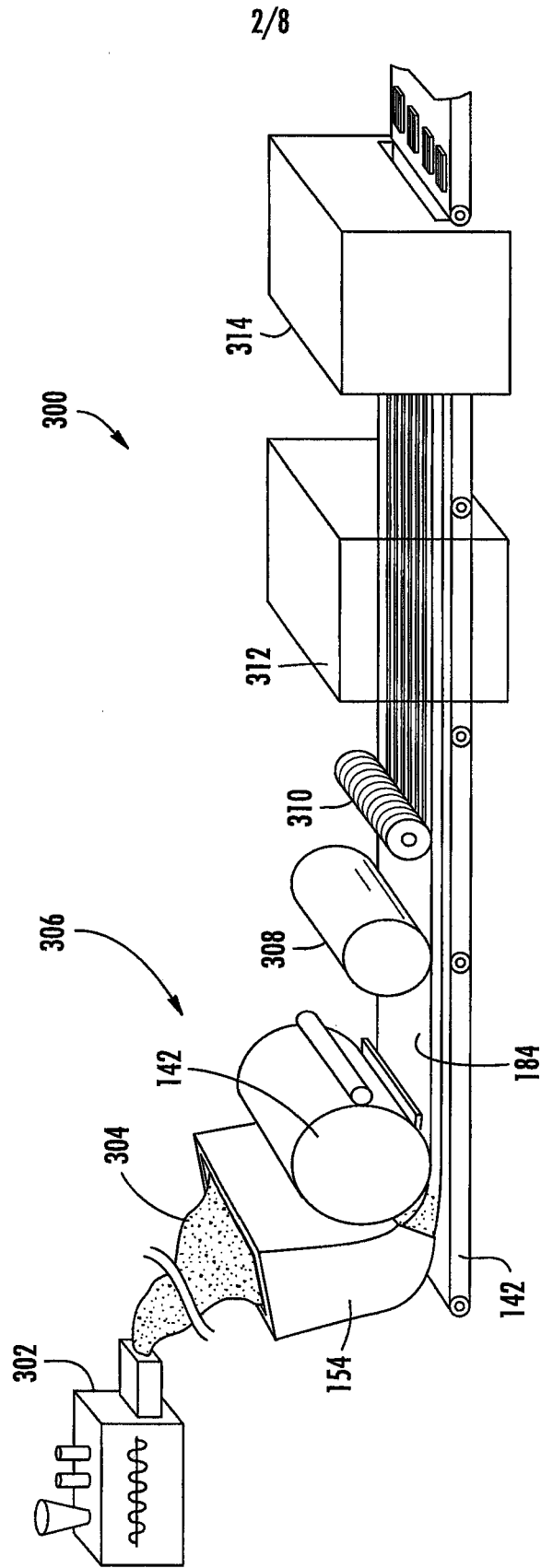

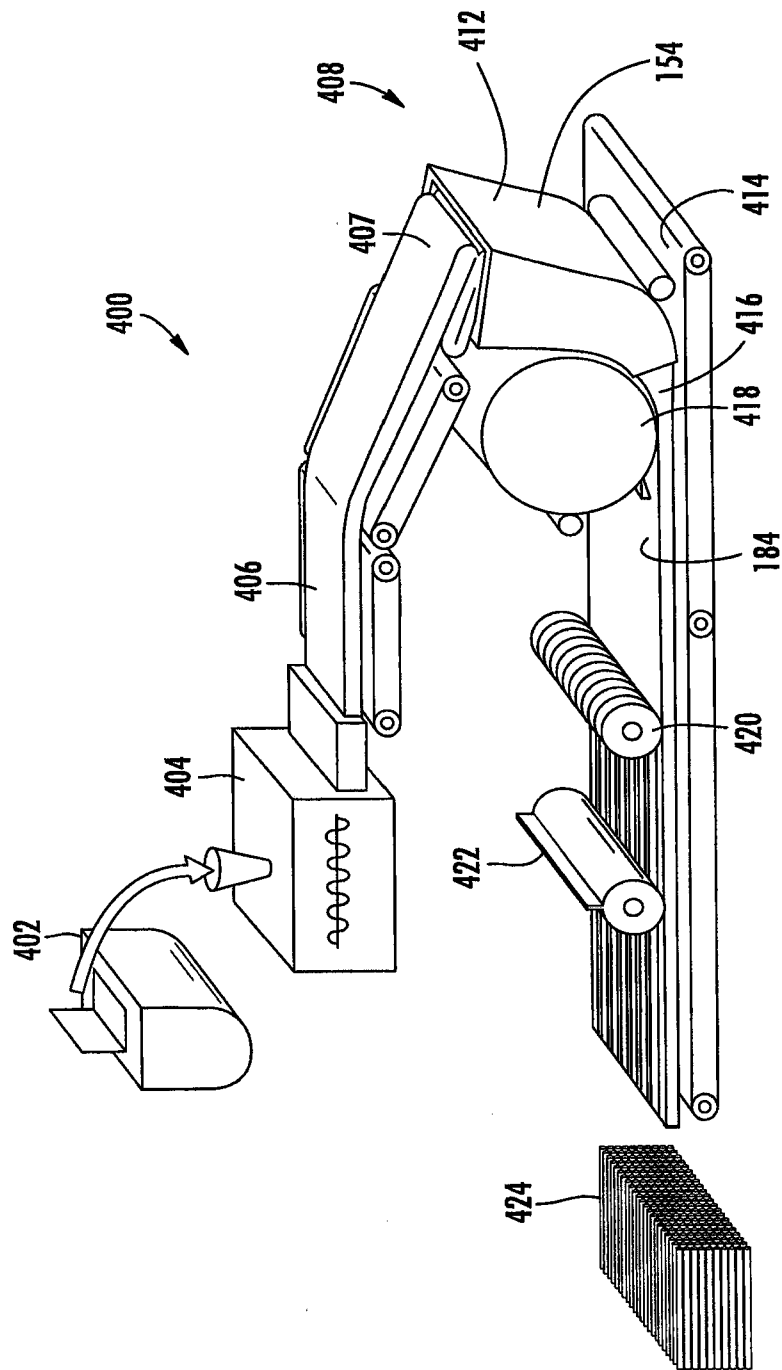

FIG. 3

Γ

4/8

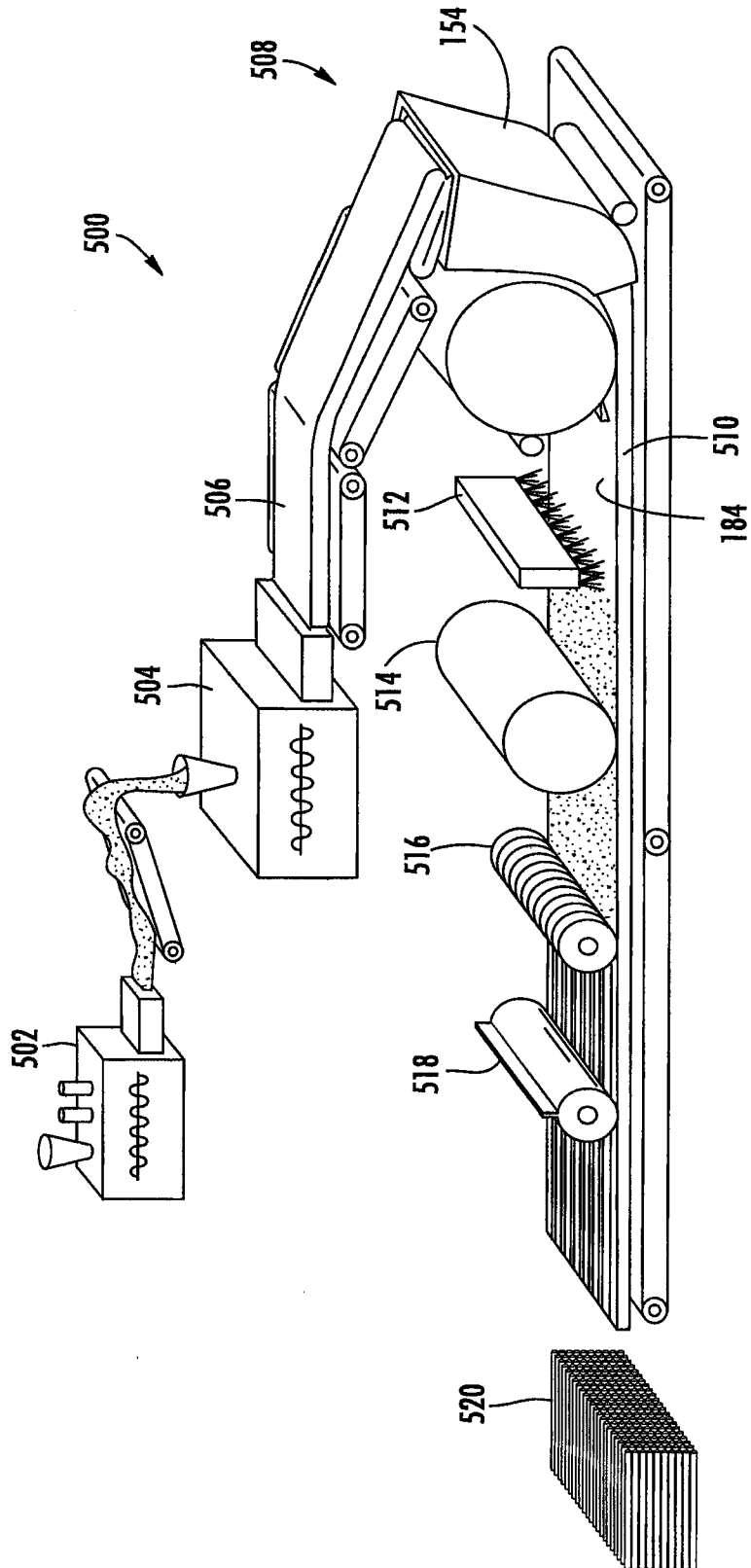

FIG. 4

5/8

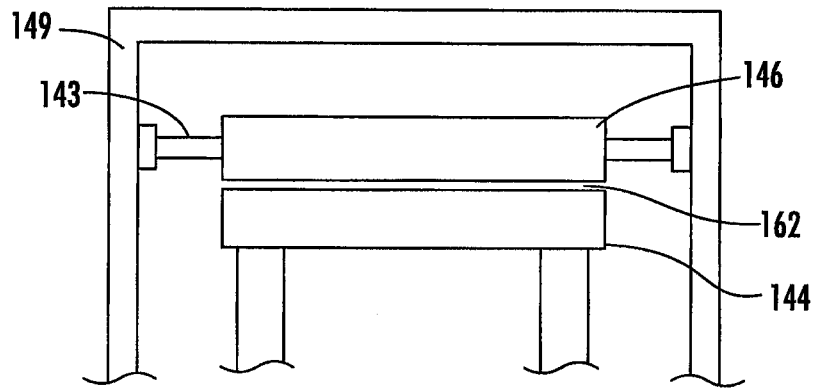

FIG. 5

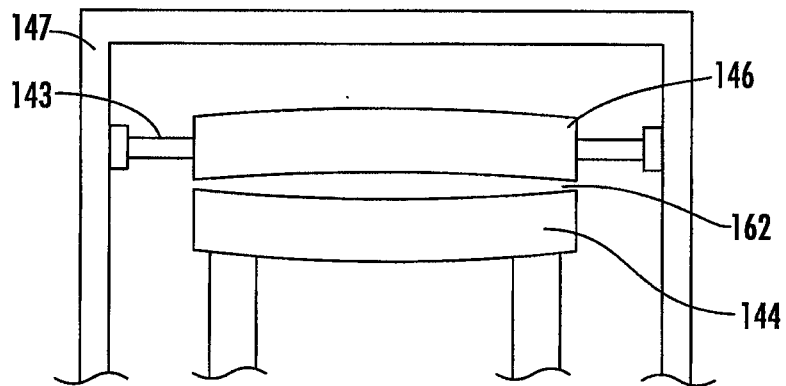

FIG. 6

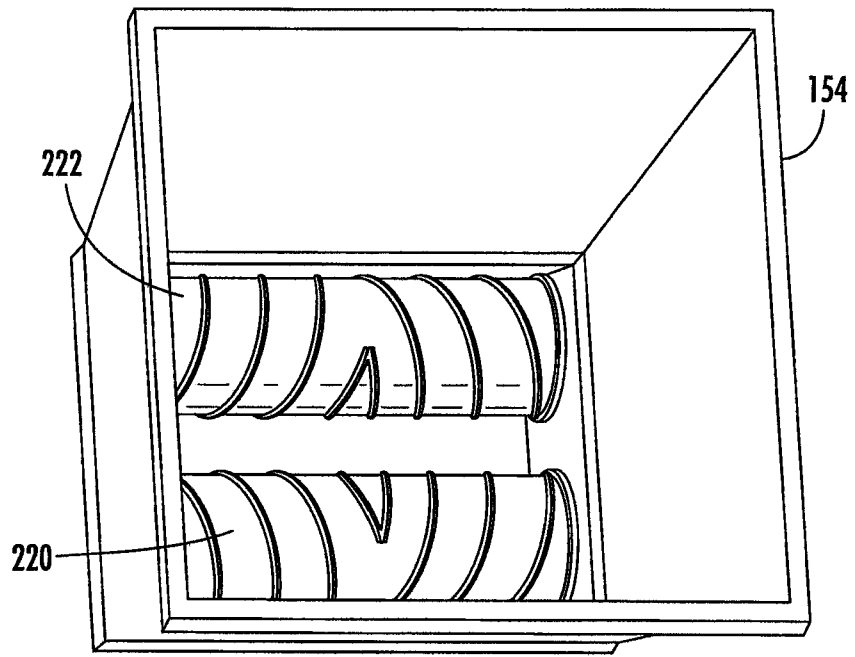

FIG. 7

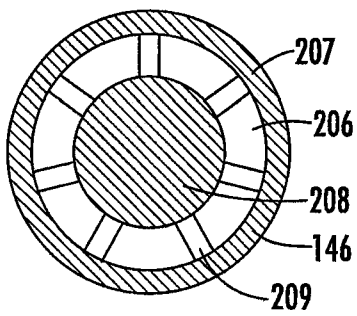

FIG. 8

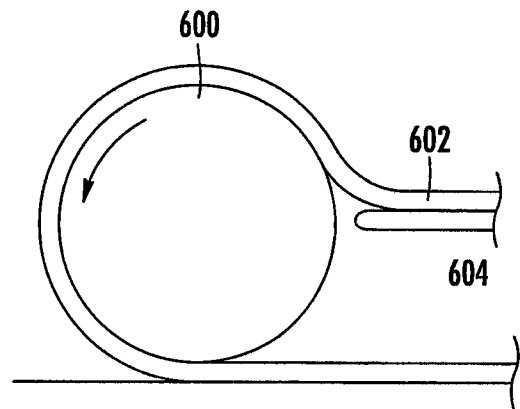

FIG. 9

7/8

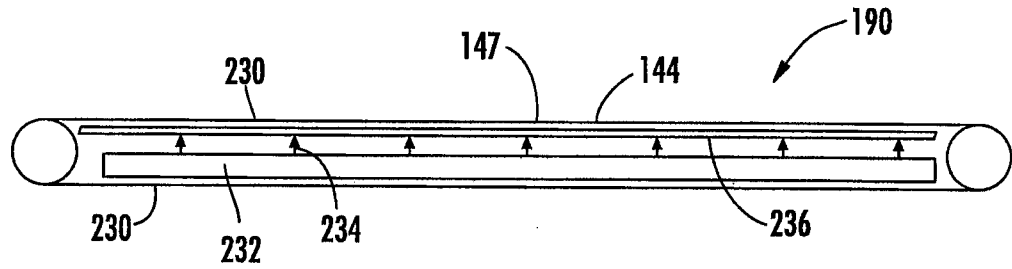

FIG. 10

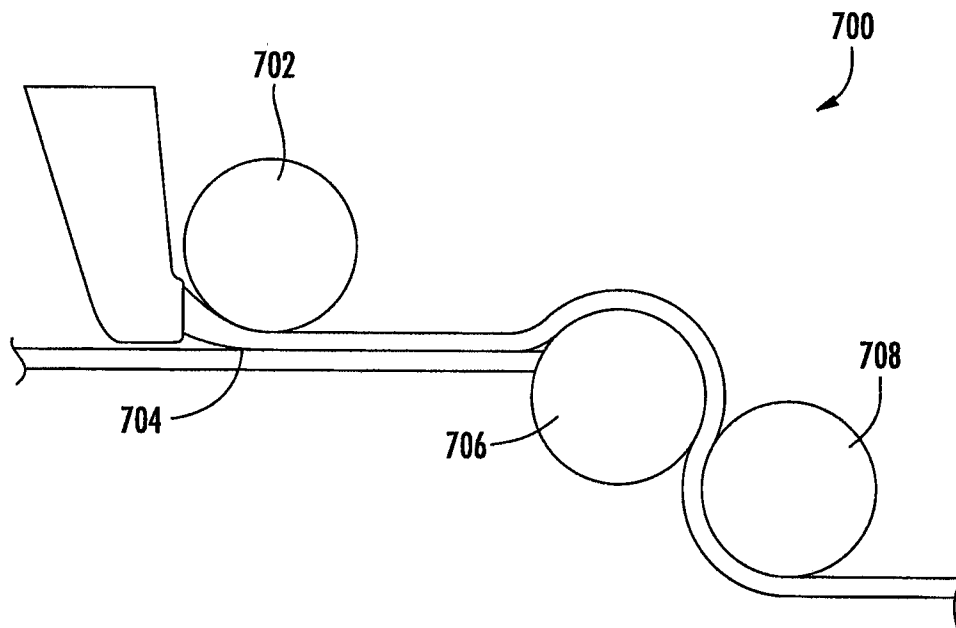

FIG. 11

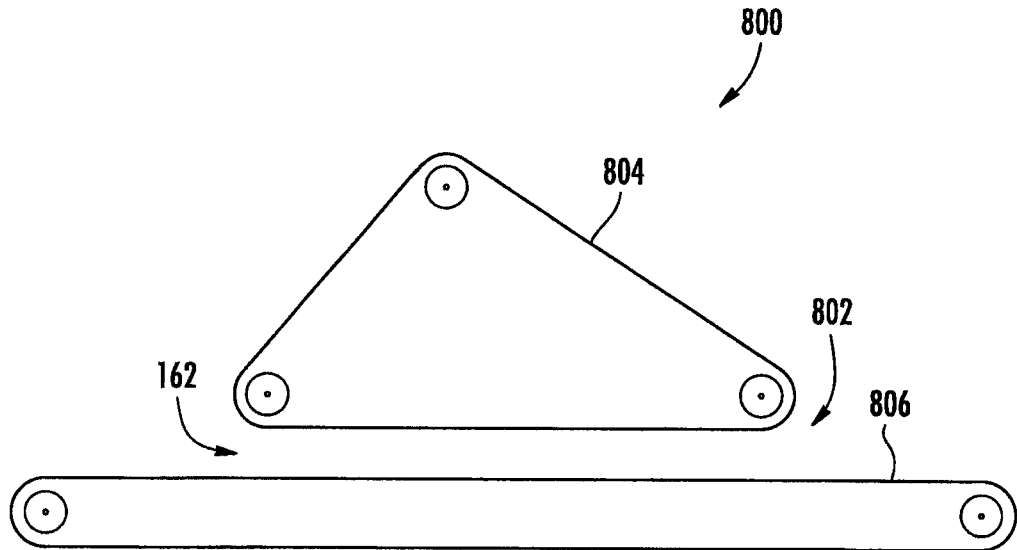

FIG. 12