

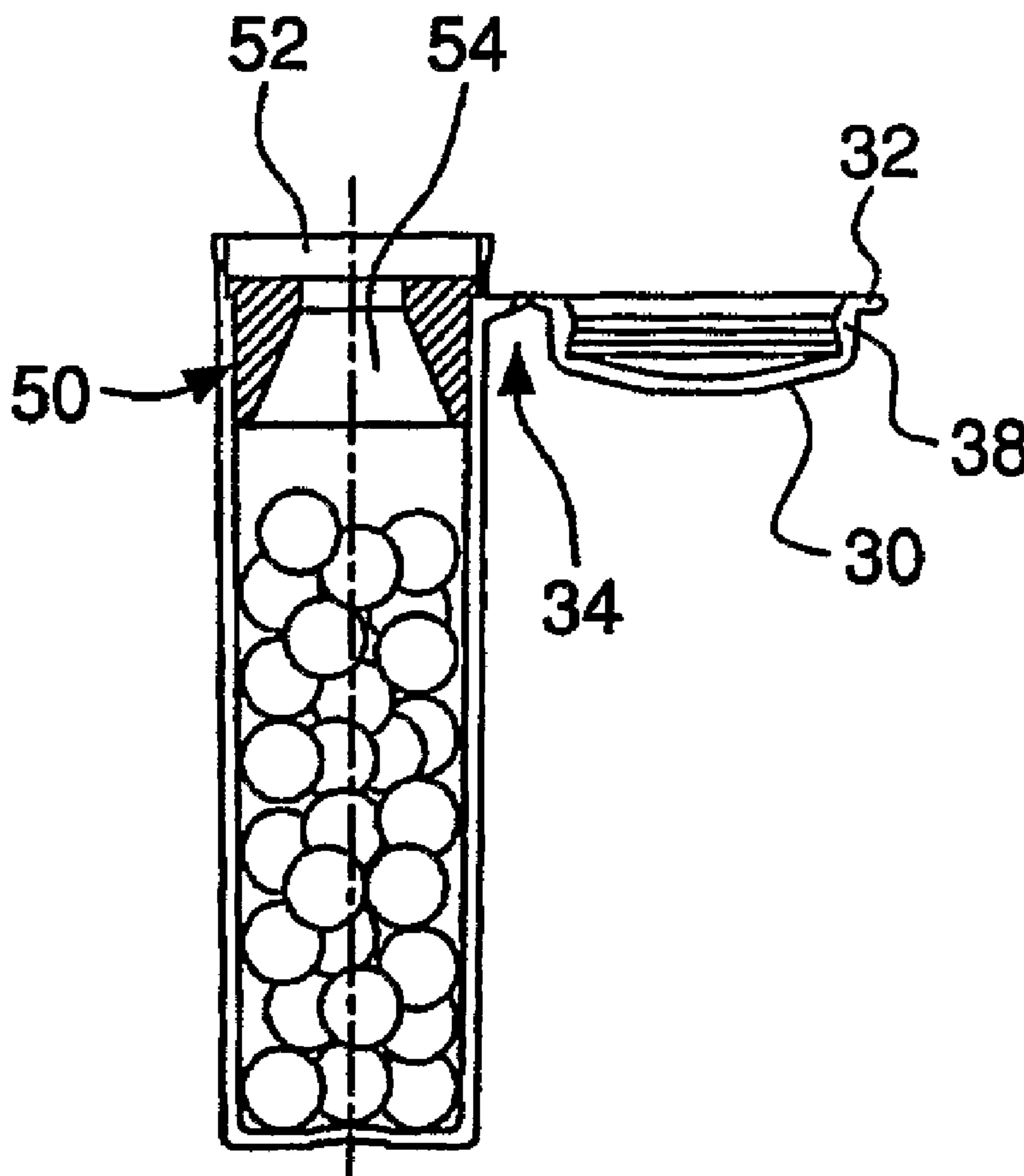

(86) Date de dépôt PCT/PCT Filing Date: 2004/10/01  
 (87) Date publication PCT/PCT Publication Date: 2005/04/21  
 (45) Date de délivrance/Issue Date: 2010/12/07  
 (85) Entrée phase nationale/National Entry: 2006/03/31  
 (86) N° demande PCT/PCT Application No.: US 2004/032369  
 (87) N° publication PCT/PCT Publication No.: 2005/035391  
 (30) Priorités/Priorities: 2003/10/02 (US60/508,183);  
 2003/10/14 (US60/510,888)

(51) Cl.Int./Int.Cl. *B65D 83/04* (2006.01)  
 (72) Inventeur/Inventor:  
 GIRAUD, JEAN PIERRE, FR  
 (73) Propriétaire/Owner:  
 CAPITOL PLASTIC PRODUCTS, LLC, US  
 (74) Agent: MCCARTHY TETRAULT LLP

(54) Titre : CONTENANT A INSERT D'ADMINISTRATION DE PILULES  
 (54) Title: CONTAINER WITH PILL DISPENSING INSERT



(57) Abrégé/Abstract:

Container assemblies for storing and delivering pills, tablets, capsules, candy or other shaped objects are disclosed herein. The container assembly includes a container (10), a cap and a dispensing insert (50, 70). The container and cap may be formed as one

(57) **Abrégé(suite)/Abstract(continued):**

piece connected by a hinge. The insert may be formed separately or as a part of the container. A process for making a molded container which includes an integral dispensing insert and cap is described. The dispensing insert is designed to dispense one pill, tablet or other shaped object at a time. When in the closed position, the container assembly can be inverted and shaken to release one pill or tablet from the container, through the dispensing insert, which remains in the area between the cap and top of the container until removed by the patient. The container assembly may be tamper-proof and/or childproof.

## (12) INTERNATIONAL APPLICATION PUBLISHED UNDER THE PATENT COOPERATION TREATY (PCT)

(19) World Intellectual Property  
Organization  
International Bureau



(43) International Publication Date  
21 April 2005 (21.04.2005)

PCT

(10) International Publication Number  
**WO 2005/035391 A3**

(51) International Patent Classification<sup>7</sup>: **B65D 83/04**

(21) International Application Number:  
PCT/US2004/032369

(22) International Filing Date: 1 October 2004 (01.10.2004)

(25) Filing Language: English

(26) Publication Language: English

(30) Priority Data:  
60/508,183 2 October 2003 (02.10.2003) US  
60/510,888 14 October 2003 (14.10.2003) US

(71) Applicant (for all designated States except US): **CAPITOL PLASTIC PRODUCTS LLC** [US/US]; 1030 Riverfront Center, P.O. Box 710, Amsterdam, NY 12010 (US).

(72) Inventors; and

(75) Inventors/Applicants (for US only): **BELFANCE, John** [US/US]; P.O. Box 189, Fonda, NY 12068 (US). **GIRAUD, Jean Pierre** 7 Rue de la Nativite F-75012 Paris [FR/FR] (FR).

(74) Agents: **PABST, Patrea, L.** et al.; Pabst Patent Group LLP, 400 Colony Square, Suite 1200, 1201 Peachtree Street, Atlanta, GA 30361 (US).

(81) Designated States (unless otherwise indicated, for every kind of national protection available): AE, AG, AL, AM,

AT, AU, AZ, BA, BB, BG, BR, BW, BY, BZ, CA, CH, CN, CO, CR, CU, CZ, DE, DK, DM, DZ, EC, EE, EG, ES, FI, GB, GD, GE, GH, GM, HR, HU, ID, IL, IN, IS, JP, KE, KG, KP, KR, KZ, LC, LK, LR, LS, LT, LU, LV, MA, MD, MG, MK, MN, MW, MX, MZ, NA, NI, NO, NZ, OM, PG, PH, PL, PT, RO, RU, SC, SD, SE, SG, SK, SL, SY, TJ, TM, TN, TR, TT, TZ, UA, UG, US, UZ, VC, VN, YU, ZA, ZM, ZW.

(84) Designated States (unless otherwise indicated, for every kind of regional protection available): ARIPO (BW, GH, GM, KE, LS, MW, MZ, NA, SD, SL, SZ, TZ, UG, ZM, ZW), Eurasian (AM, AZ, BY, KG, KZ, MD, RU, TJ, TM), European (AT, BE, BG, CH, CY, CZ, DE, DK, EE, ES, FI, FR, GB, GR, HU, IE, IT, LU, MC, NL, PL, PT, RO, SE, SI, SK, TR), OAPI (BF, BJ, CF, CG, CI, CM, GA, GN, GQ, GW, ML, MR, NE, SN, TD, TG).

**Published:**

- with international search report
- before the expiration of the time limit for amending the claims and to be republished in the event of receipt of amendments

(88) Date of publication of the international search report:  
16 June 2005

For two-letter codes and other abbreviations, refer to the "Guidance Notes on Codes and Abbreviations" appearing at the beginning of each regular issue of the PCT Gazette.

(54) Title: CONTAINER WITH PILL DISPENSING INSERT

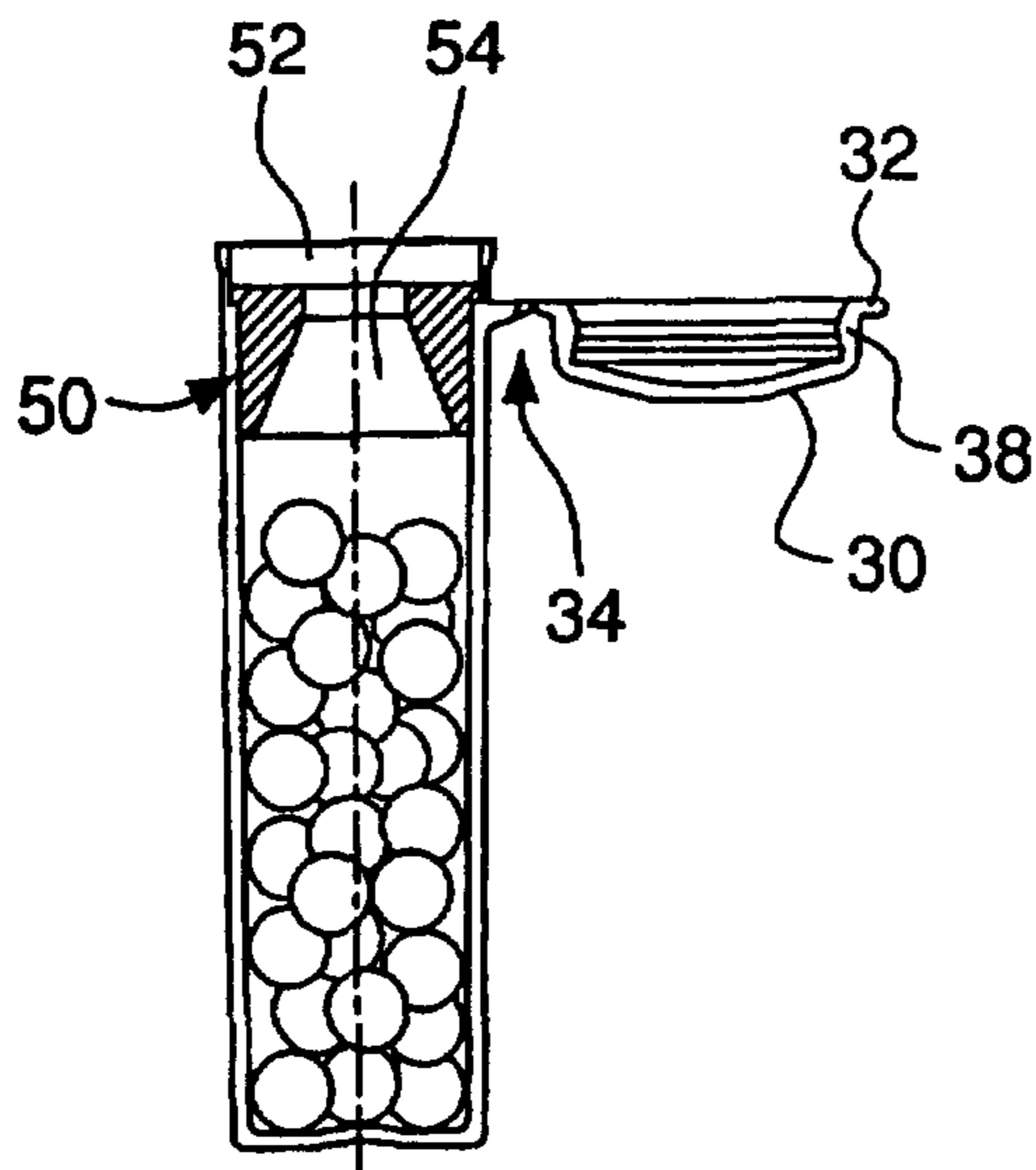

(57) Abstract: Container assemblies for storing and delivering pills, tablets, capsules, candy or other shaped objects are disclosed herein. The container assembly includes a container (10), a cap and a dispensing insert (50, 70). The container and cap may be formed as one piece connected by a hinge. The insert may be formed separately or as a part of the container. A process for making a molded container which includes an integral dispensing insert and cap is described. The dispensing insert is designed to dispense one pill, tablet or other shaped object at a time. When in the closed position, the container assembly can be inverted and shaken to release one pill or tablet from the container, through the dispensing insert, which remains in the area between the cap and top of the container until removed by the patient. The container assembly may be tamper-proof and/or childproof.

WO 2005/035391 A3

## CONTAINER WITH PILL DISPENSING INSERT

### FIELD OF THE INVENTION

The present invention relates to container systems with dispensing inserts.

5

### BACKGROUND OF THE INVENTION

Typically when opening a pill container, the pills can spill out of the container. This allows moisture and other contaminants to enter the container. Additionally, one can easily lose some of the pills. There is a need for improved containers for pills that administer only one pill at a time.

10

Therefore it is an object of the invention to provide an improved container for medicines that prevents the pills from spilling out of the container when it is opened.

### BRIEF SUMMARY OF THE INVENTION

Container assemblies for storing and delivering pills, tablets, capsules, candy or other shaped objects are disclosed herein. The container assembly includes a container, a cap and a dispensing insert. The container and cap may be formed as one piece connected by a hinge. The insert may be formed separately or as a part of the container. A process for making a molded container which includes an integral dispensing insert and cap is described. The dispensing insert is designed to dispense one pill, tablet or other shaped object at a time. When in the closed position, the container assembly can be inverted and shaken to release one pill or tablet from the container, through the dispensing insert, which remains in the area between the cap and top of the container until removed by the patient. The container assembly may be tamper-proof and/or childproof.

15

20

## BRIEF DESCRIPTION OF THE DRAWINGS

Figures 1A-1B are side views of one embodiment of the container assembly showing the container and the integrally attached cap. Figure 1A is a prospective side view of the container and the closed cap showing the hinged side of the cap. Figure 1B is a prospective side view of the container and the closed cap showing the tabbed side of the cap.

Figures 2A-2B are overhead views of the integrally attached cap in a closed (Figure 2A) and in an open position with the dispensing insert placed within the upper portion of the container (Figure 2B). Figure 2C is a cross-sectional side view of the dispensing insert.

Figures 3A-3B are cross-sectional side views of two embodiments of the container assembly showing the open container and the integrally attached cap with the dispensing inserts placed within the upper portion of the container.

Figures 4A-4B are cross-sectional side views of the container with closed cap (Figure 4A) and open cap (Figure 4B), showing a petal like insert and desiccant lining in the container.

Figures 5A-5B are perspective views of the closed cap (Figure 5A) and petal like insert (Figure 5B) of the container of Figures 4A-4B.

Figures 6A-6B are perspective views of the mold and container with integral insert and cap.

## DETAILED DESCRIPTION OF THE INVENTION

### I. Definitions

As generally used herein, "empty stage" refers to a stage when the container is empty prior to filling, such as when the container is shipped by the manufacturer of the container to the site where items are placed inside the container.

As generally used herein, "filling stage" refers to a stage after the container has been filled with its content.

As generally used herein, "tamper-proof seal" means a visual indication that: (a) when not broken, the container's cap has not been

opened; and (b) when broken, the container cap has been opened and thus, visually displays that the container was tampered with.

## II. Container, Cap and Dispensing Insert Assembly

The container may have any shape that is suitable for storing pills, tablets or other shaped objects. In the preferred embodiment, the container is in the shape of a cylinder. Typically, the container is closed at one end and is open at the opposite end. Optionally, when the container is closed, the container is moisture tight.

The cap is typically attached to the container by way of a hinge. The cap also has a mating sealing element that interfaces with the open end of the container, thereby forming a container and cap assembly.

The assembly is preferably molded of plastic. Suitable material for assembly includes plastics like thermoplastics such as polypropylene and polyethylene. The cap 30 and the container 10 may be integrally molded of plastic to form a hinge 34 there between. In another embodiment, the cap 30 and the container 10 may be produced in a conventional molding process. The assembly may be produced in accordance with the operation disclosed in U.S. Patent Nos. 4,783,056 to Abrams, RE37,676 to Abrams *et al.* or 6,303,064 to Abrams *et al.*

### 1. Container

The container assembly is depicted in Figures 1A-1B, 3A-3B, and 4A-4B. The cap and insert assembly is shown in Figures 2A-2C. As depicted in these figures, the assembly includes a container 10 having a base 16, an internal cavity 18, an outer surface 12, and an upper portion 14. The container 10 has a rim 20 at the top of the upper portion 14. The container 10 also has a partial flange 14 extending radially outwardly from the outer surface 12 of the container 10.

The container may be of a sufficient size to store for example, 10 to 200 pills, tablets or other shaped objects, preferably less than 150, more preferably less than 100 or less than 50. The pills or objects typically range in size from about 2 mm to about 20 mm in diameter, preferably from about

4 mm to about 9 mm in size. The size of the pills, tablets or other shaped objects is approximately equivalent to the size of the hole in the dispensing insert. Although depicted as a cylindrical container, it is understood that the container could be made in a variety of container assembly designs, including but not limited to designs having non-cylindrical container assembly shapes.

Optionally, the container includes a lining of a material that absorbs or releases materials, as discussed below with respect to Figures 4A and 4B. As an example, if the material absorbs water vapour, it may be included to keep the contents at a low relative humidity since any moisture that permeates through the seal or is present in the container would be absorbed. The lining material may be a desiccant entrained plastic. Suitable desiccant plastics include, but are not limited to those disclosed in U.S. Patent Nos. 5,911,937; 6,214,255; 6,130,263; 6,080,350; 6,174,952; 6,124,006; 6,221,446; and 6,486,231, all to Hekal. By varying the desiccant loading and channeling agent in the plastic formulation, the overall moisture capacity and uptake rate of the desiccant entrained plastic can be controlled. The plastic may be entrained with other absorbing, releasing or activation components. The lining may release a gas, such as an inert gas that prevents oxidation of the enclosed medicament, a flavouring or fragrance, or moisture, in the case of a medicament that should not be allowed to dry out. U.S. Patent Nos. 6,174,952, 6,177,183, 6,194,079, 6,316,520, 6,124,006, 6,221,446, and 6,486,231 describe these kinds of arrangements.

In one embodiment, the desiccant entrained plastic is located in a desiccant sleeve, which surrounds at least a portion of the product within the container. In yet another embodiment, the sleeve surrounds the container assembly interior with a thin-walled plastic so that the product contained within the container assembly is completely surrounded by the desiccant entrained plastic sleeve. The items contained in the container may be

exposed to about fifty times less moisture when compared to a conventional stoppered container.

## 2. Cap

As shown in Figures 1 through 5, the assembly includes a cap 30  
5 which has a solid base 36 and a tubular skirt 38 extending perpendicularly  
and outwardly around the outer periphery of the base 36. The cap 30 is  
typically attached to the container 10 by a hinge 34. The cap 30 has a tab 32  
for facilitating the opening and closing of the container 10 at the end  
opposite the hinge 34. The tab 32 extends perpendicularly and outwardly  
10 from the skirt of the cap 38. The container 10 also has a partial flange 14  
extending radially outwardly from the outer surface 12 of the container 10  
and ending where a thumb tab 32 of cap 30 comes in contact with container  
10. The hinge 34 has a recess 35 that functions as a binding point for ease of  
opening and closing of the container 10. Optionally, the hinge 34 is attached  
15 to the container at or near the container flange 14.

The base 36 of the cap 30 has an inner surface 40 and an outer  
surface 42. In one embodiment, an inner collar 62 is joined to the inner  
surface 40 of the base 36 of the cap 30. As discussed below, this can be used  
to seal the dispenser insert opening.

20 While the figures depict the hinge 34 as integral with the cap 30 and  
container 10, the skilled artisan will readily appreciate that any kind of hinge  
may be employed, or that a hinge may not be required. In one embodiment,  
the hinge is formed from a plurality of components. For example, a hinge  
component attached to the cap may be engaged with a hinge component  
25 attached to the container. In another embodiment, the container and cap are  
joined together by a hinge. In this embodiment, the container assembly is an  
interconnected assembly in which the cap is opened and closed in a “flip-  
top” arrangement. Alternatively, the hinge is integral with the cap and  
container, which provides a one-piece container assembly.

30 The container assembly may contain an “easy-to-close” cap design,  
in which the container assembly is specifically designed to be in one of only  
two states: (1) open or (2) completely closed. The closure arrangement is

designed so that the cap cannot be partially closed or cross-threaded. If the cap does not seal properly, it will pop up to the open position.

Optionally, the cap is designed so it can be closed with one hand. Thus, the user should be able to close the cap from any position with respect to the hinge (front, side or back of container assembly). U.S. Patent No. 6,769,558 to Bucholtz describes this arrangement.

In yet another embodiment, the container assembly maintains seal performance after repeated lid openings and closings. For example, the seal maintains a low ingress rate after repeated lid openings/closings. In one specific example, the seal maintains its low moisture ingress performance after 50 cycles of lid openings and closings. U.S. Patent Nos. 4,812,116; 4,807,425; 5,723,085; and 6,769,558, and European patent document no. EP 625 948 to Capitol Vial Inc., describe examples of embodiments of this sealing arrangement.

### 3. *Dispensing Insert*

Dispensing insert 50 has a hole 52 for dispensing pills, tablets or other shaped objects and the hole is sized so that one pill, tablet, capsule, candy or other shaped object can fit through the hole in the dispensing insert at a time. The dispensing insert 50 can be of any shape that fits inside of the container 10. Preferably the insert 50 is round. The insert 50 may have an outer diameter that is slightly larger than the inner diameter of the container 10 so that the insert 50 fits snugly in the upper portion 14 of the container. The insert 50 may be maintained in the upper portion 14 of the container due to pressure or friction ("pressure fit" or "friction fit"). Alternatively, the insert 50 has a diameter that is slightly smaller than the inner diameter of the container. In this embodiment, the insert 50 is secured by a suitable fixation means, such as an adhesive or welding.

In one embodiment, hole 52 has a diameter that is substantially equivalent to the size of the pill, tablet or other shaped object so that when cap 30 is closed, the container assembly 1 must be shaken to dispense one

object through insert 50 and into collar 62 (e.g. turning container assembly 1 upside down).

In yet another embodiment, collar 62 works in conjunction with insert 50 to dispense one object into the closed cap. Thus, collar 62 is sized  
5 so that collar 62 can work with insert 50. Subsequently, cap 62 is removed and the object is presented on insert 50 for removal.

Figure 3B illustrates another example of the geometry of insert 50. As shown in Figure 3B, the hole 54 has a frusto-conical shape so that the pill can be dispensed from container 10 but will not move back into container 10.  
10 In the example shown in Figure 3A, the hole 52 is substantially planar so that the pill remains in the dispensing area, i.e. the area above insert 50 and in cap 30 and within collar 62, when the cap is in the closed position. It is understood that other geometries of the top and bottom portion and hole may be used to achieve the result of dispensing the object from the container and  
15 holding the object in the dispensing area.

In another embodiment shown in Figures 4A-4B and 5A-B, the insert 70 is configured in the shape of a petal with solid leaves 72. In another embodiment, the profile of the container's inner side wall 74 is designed with a 'step' 76 above the petals to accommodate the opening of the petals during  
20 the mold opening cycle. This step 76 along the inner side wall 74 is approximately equal to the thickness of the petal leaves 72.

In another embodiment the container assembly with the insert is manufactured in a single molding cycle and made out of one piece (e.g. no assembly in the mold). The advantages of a single molding process includes  
25 manufacturing in a completely sterile process, which is preferred for pharmaceutical applications.

As shown in Figures 6A and 6B, in one embodiment, the mold 80 includes a two-part long core 82 that forms the petal-like insert 70 along the container's inner side walls 74. When the mold 80 is closed, the two-part  
30 long core 82 forms the cavity 84 for the insert 70. During the injection cycle, the petal leaves 72 of the insert 70 are filled from the container's side walls 74. After the part is molded, the long core 86 is retracted in a two step

process: (1) the cavity 84 that forms the petal opening 78 separates and (2) the long core 86 separates into two pieces 86a and short core 86b and is retracted. When the long core 86 is retracted, the petal leaves 72 are opened into a vertical orientation with respect to the container's side wall 74.

5           As noted above, the container's inner side wall 74 is designed with a 'step' 76 above the petal leaves 72 to accommodate the opening of the petal leaves 72 during the mold opening cycle. This step 76 along the inner side wall 74 is approximately equal to the thickness of the petal leaves 72. The opened insert 70 permits the long core 86 to exit through the insert 70 without damaging the petal leaves 72. Once the mold 80 is fully retracted, the petal leaves 72  
10          return to the normal position, perpendicular to the container side walls 74.

          In a further embodiment, the mold 80 may also incorporate one or more of the following mold features: (1) a short core with an active flipper 90 to close the cap in the mold; (2) the injection point 92 at the bottom of the container; (3) a stripper plate 96; and/or (4) a mold design to accommodate an in-mold liner 98 of desiccant entrained plastic along the inner walls. The  
15          container with desiccant lining 78 is shown in Figures 4A and 4B.

#### 5.        *Child Safety and/or Tamper Proof Features*

          In yet another embodiment, a child resistance feature may be incorporated into the container assembly.

          A tamper evidence feature that is molded into the container assembly may be employed.  
20          Shrink-wrap may be used to cover the cap and all or a portion of the container. Alternatively, a two-position, breakaway tab may be used. An example of the two-position, breakaway tab is disclosed in U.S. Patent No. 6, 398, 067 to Belfance and Supranowicz. The tab is engaged during container assembly filling, and the tab is ejected from the container assembly when first opened by the user. Evidence of tampering with the container is apparent from the broken tab. It will be  
25          appreciated that it may not be

possible to replace the tab once it has broken, since the tab is formed integrally with the container. Therefore, it should not be possible to defeat the tamper-proof capabilities. It will also be appreciated that the interlocked tab may also aid in preventing dislodgement of the cap during transport.

5           The cap 30 has a base 36 with a skirt 38 extending perpendicularly and outwardly around the outer periphery of the base 36, and the cap 30 has a hinge 34 and a tab 32 extending perpendicularly and outwardly from the skirt 38 of the cap, as described above with reference to Figures 1 and 2. In this embodiment, the cap can include a first slot and a second slot (not shown) including an interlocking device for engaging with a protrusion on the container 10 (not shown). When the container is in an empty state, the protrusion is positioned within the first slot, and when the container is in a filled stage, the cap is placed upon the container and the protrusion is repositioned within the second slot causing the contact element of the protrusion to engage the interlocking device of the second slot and thus to form a tamper-proof seal.

15           In yet another embodiment, the protrusion is formed in such a way that, if the cap is opened (*i.e.* tampered with), the protrusion will break off and thus, evidence of tampering with the container will be evident by the broken protrusion. It will be appreciated that it may not be possible to replace the protrusion once it has broken, since the protrusion is formed integrally with the container. Therefore, it should not be possible to defeat the tamper-proof capabilities by replacing the original broken protrusion. It will also be appreciated that the interlocked protrusion not only provides tamper-proof function, but also may aid in preventing dislodgement of the cap during transport.

25           In another embodiment, a tamper evidence feature is molded into the container assembly. An example is achieved with a two-position, breakaway tab that is disclosed in U. S. Patent No. 6,398, 067. The tab is engaged during container assembly filling, and the tab is ejected from the container assembly when first opened by the user.

## II. Method of using Container Assembly

In operation, container 10 is filled with the desired shaped object and then, after filling, insert 50 is inserted into container 10. Subsequently, cap 30 is fitted onto container 10 to form a final product.

5           The container assembly can store a number of pills, tablets or other shaped objects, including items that require storage in a moisture-free environment. For example, stored objects may be candy, pharmaceutical products, and/or vitamins. The tables may be effervescent tablets.

10           When in the closed position, the container assembly can be inverted and shaken to release one pill or tablet from the container, through the dispensing insert. The pill or tablet will remain in the area between the cap and top of the container.

15           Those skilled in the art will recognize, or be able to ascertain using no more than routine experimentation, many equivalents to the specific embodiments of the invention described herein. Such equivalents are intended to be encompassed by the following claims.

## WE CLAIM:

1. An insert for dispensing a single tablet, pill, or capsule, suitable for insertion into an open end of a container, the insert having an upper portion and a lower portion, comprising a central opening having a diameter sized to allow passage of only a single tablet, pill or capsule, extending from the upper portion to the lower portion of the insert wherein the insert comprises multiple abutting leaves attached at their base to the outer periphery of the insert and extending towards the center of the insert, wherein the leaves are truncated to form an opening in the center of the insert.
2. The insert of claim 1 wherein the leaves are substantially the same size and shape.
3. The insert of claim 1 extrusion molded of a thermoplastic or thermoset polymer.
4. The insert of claim 1 wherein the insert comprises an upper and a lower portion wherein the outer diameter of the upper portion of the insert is larger than the inner diameter of the container and the diameter of the lower portion of the insert is smaller than the inner diameter of the container so that the insert can be inserted into the container.
5. A container comprising an insert according to any one of claims 1 to 4.
6. A container according to claim 5 further comprising a cap.
7. The container of claim 6 wherein the cap is attached to the upper portion of the container so that it closes onto the upper portion of the insert.
8. The container of claim 6 wherein the cap is attached to the container by a hinge.
9. The container of any one of claims 5 to 7 wherein the cap comprises a collar sized to fit into and abut the edges of the central opening of the insert.
10. The container of claim 5 or 6 wherein the cap comprises a tab for easy opening.

11. The container of claim 6 wherein the cap and container comprise a child resistant or tamper proof fastener.
12. The container of claim 5 or 6 further comprising a flange around the outer surface of the upper portion of the container, which abuts the lower edge of the cap when closed onto the container.
13. The container of claim 5 or 6 wherein the insert is integral with the container.
14. The container of claim 5 or 6 further comprising an absorbent or insert releasing a gas.
15. The container of claim 14 wherein the absorbent is in the form of a desiccating liner.
16. The container of claim 5 extrusion molded of a thermoplastic or a thermoset polymer.
17. A method for storing pills, tablet or capsules comprising placing them in the container for any one of claims 5 to 15 and closing the cap.
18. A method of making a container comprising an integral insert for dispensing a single tablet, pill or capsule, suitable for insertion into an open end of the container, the insert having an upper portion and a lower portion, comprising a central opening having a diameter sized to allow passage of only a single tablet, pill, or capsule, extending from the upper portion to the lower portion of the insert, wherein the insert comprises multiple abutting leaves attached at their base to the outer periphery of the insert and extending towards the center of the insert, wherein the leaves are truncated to form an opening in the center of the insert, the method comprising  
providing a mold including a two-part long core that forms a petal-like leaves along the container's inner side walls, wherein when the mold is closed, the two-part long core forms a cavity for the insert, wherein during the injection cycle, the petal leaves of the insert are filled from the container's side walls, and wherein after the part is molded, the long core is retracted so the cavity that forms the petal opening separates and the long core separates into two pieces and is retracted to open the petal leaves.
19. A mold for use in the method of claim 18.

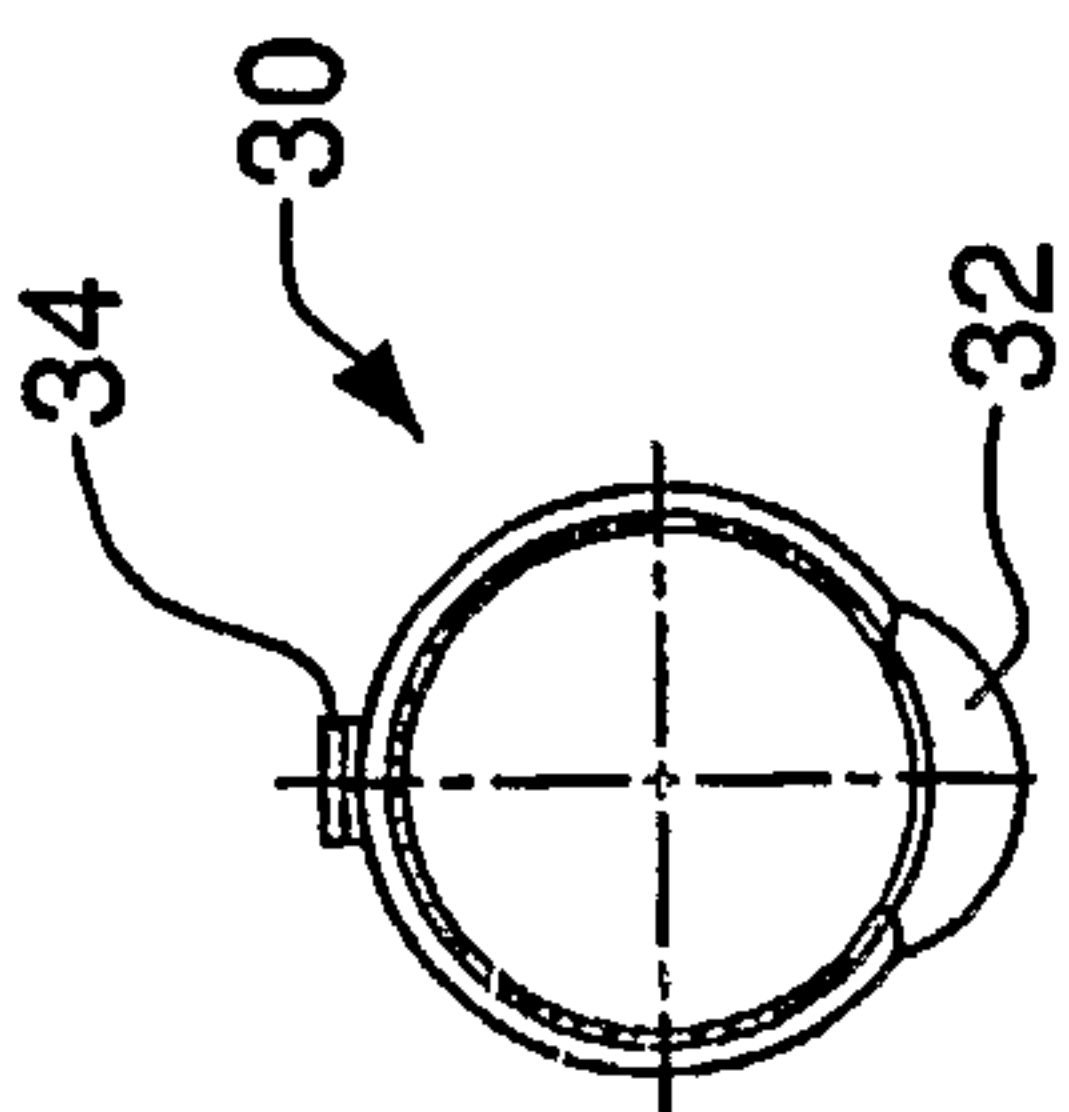

FIG. 2A

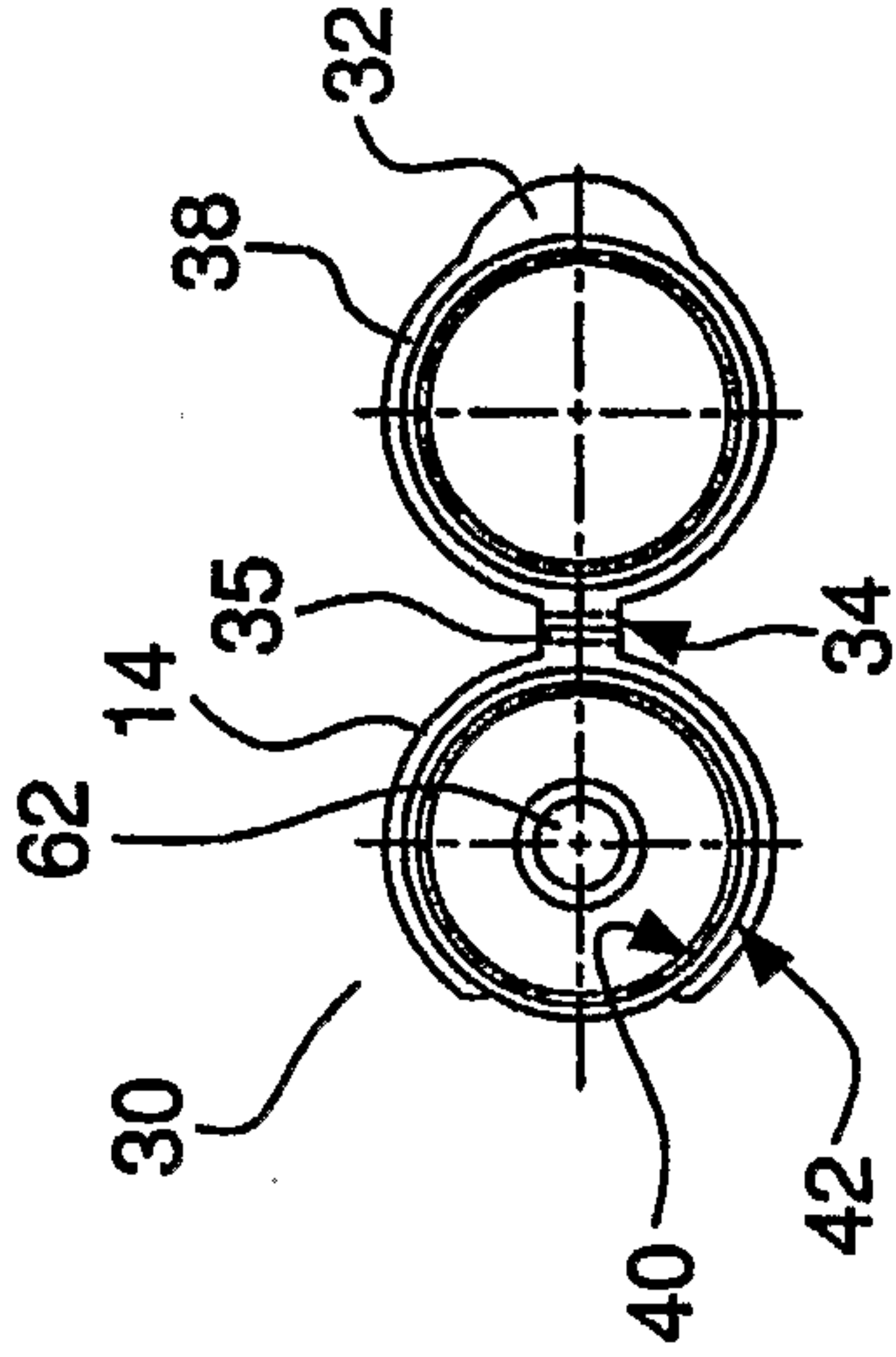

FIG. 2B

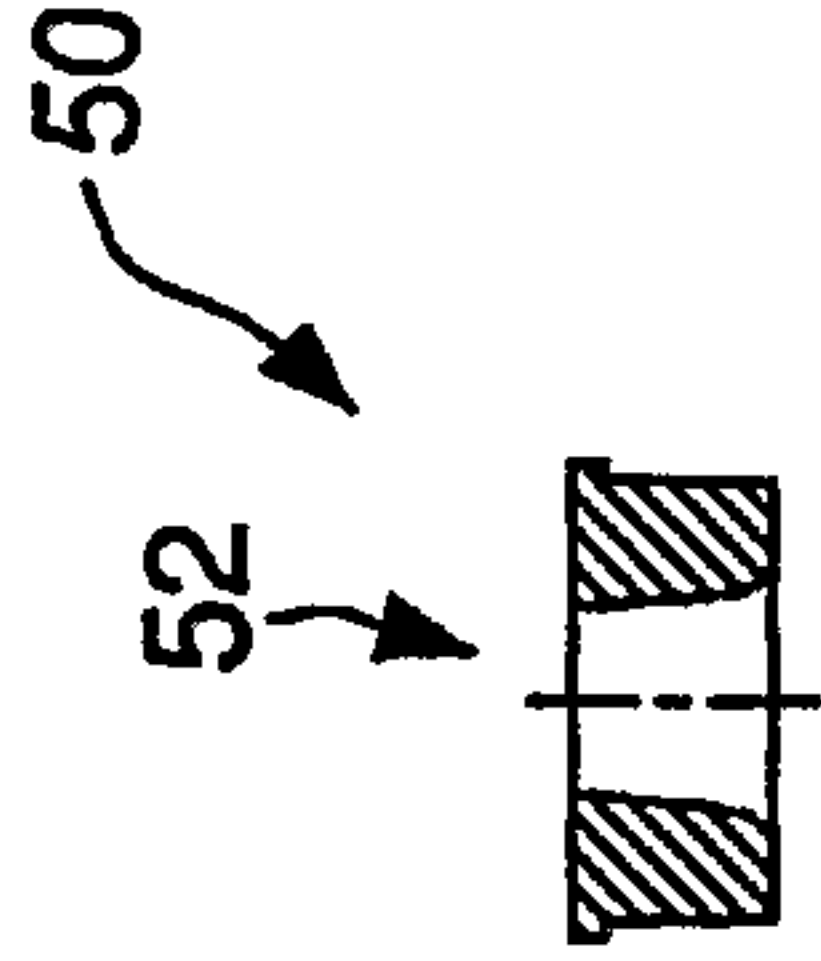

FIG. 2C

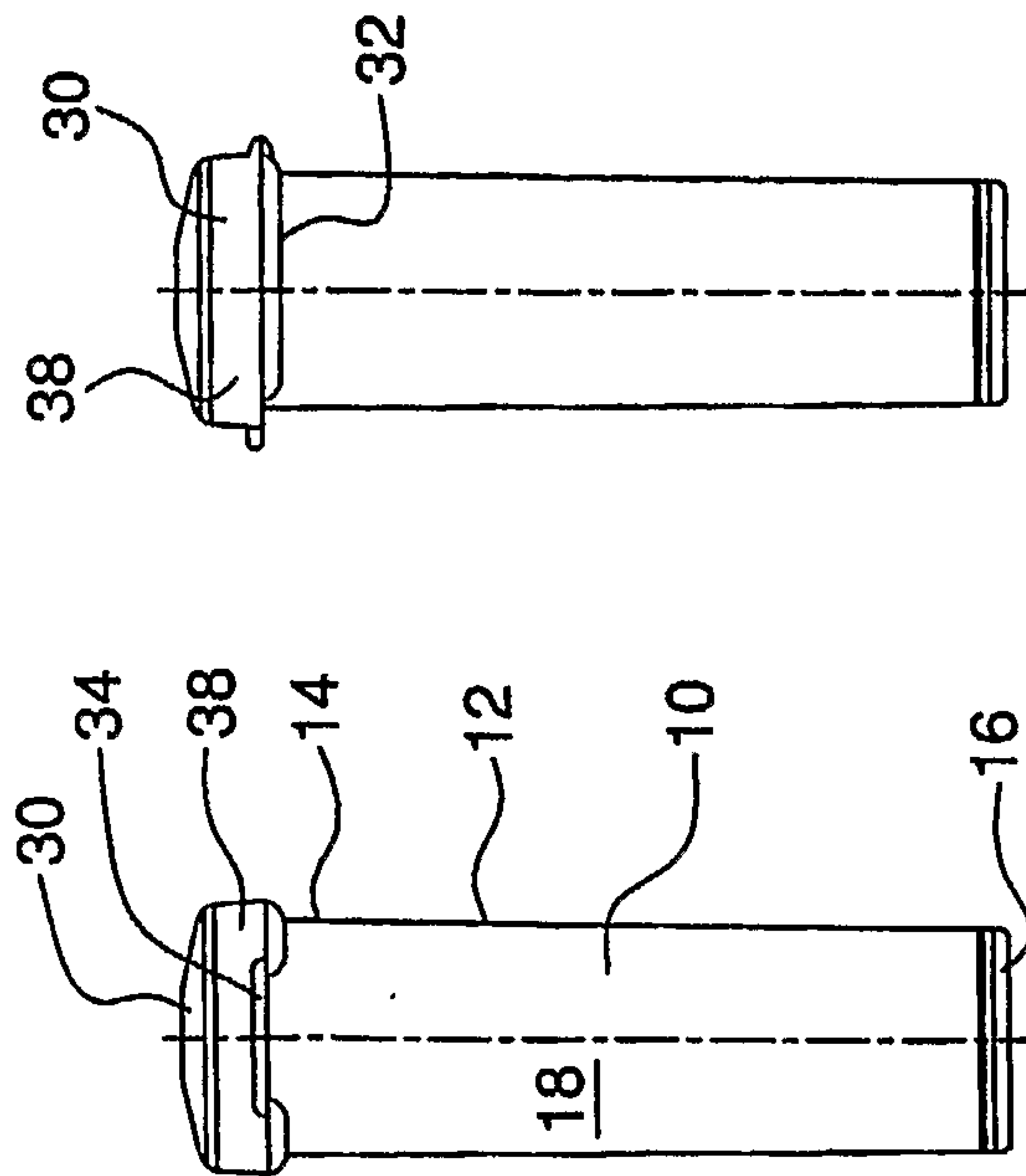

FIG. 1A

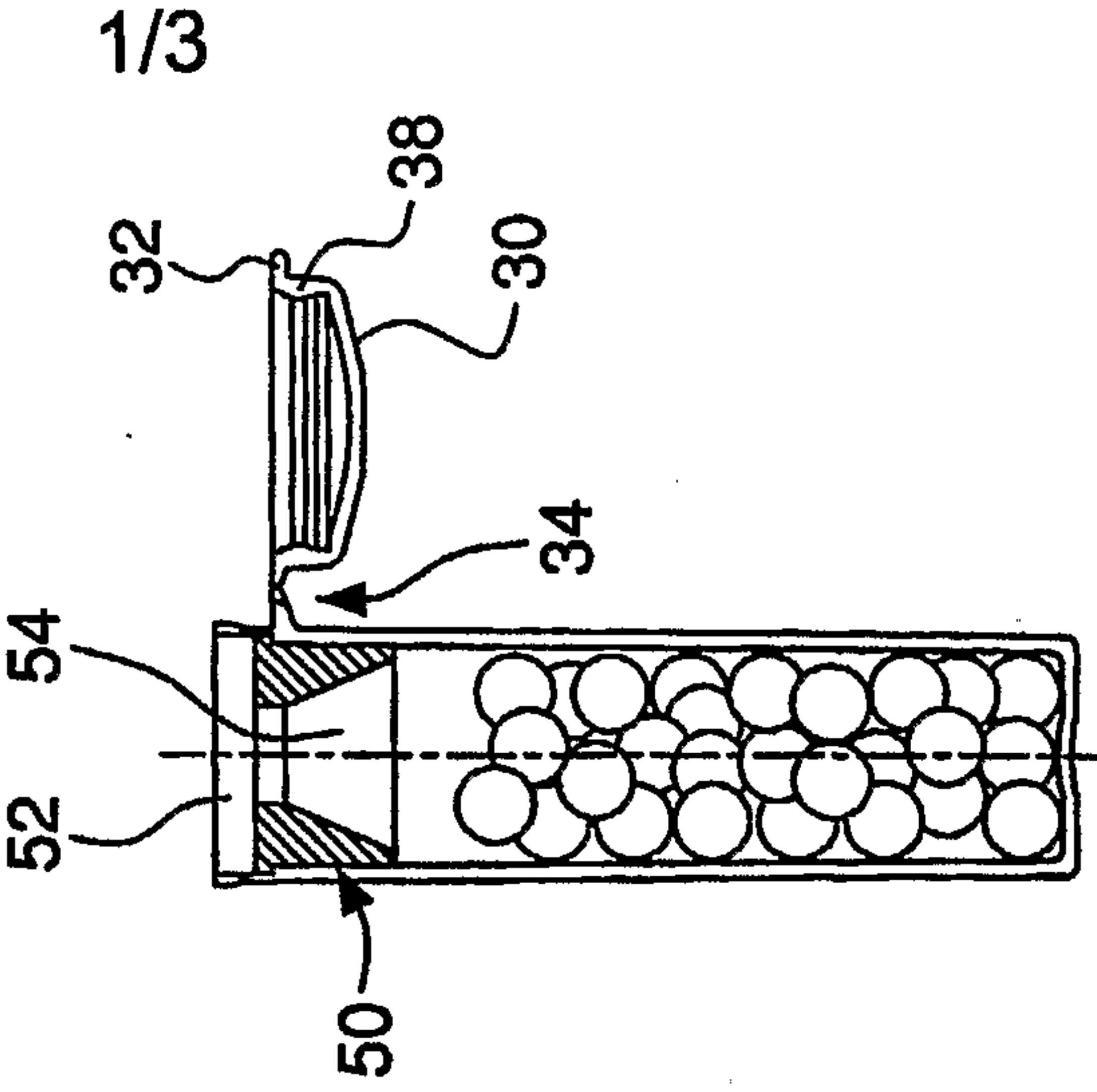

FIG. 3A

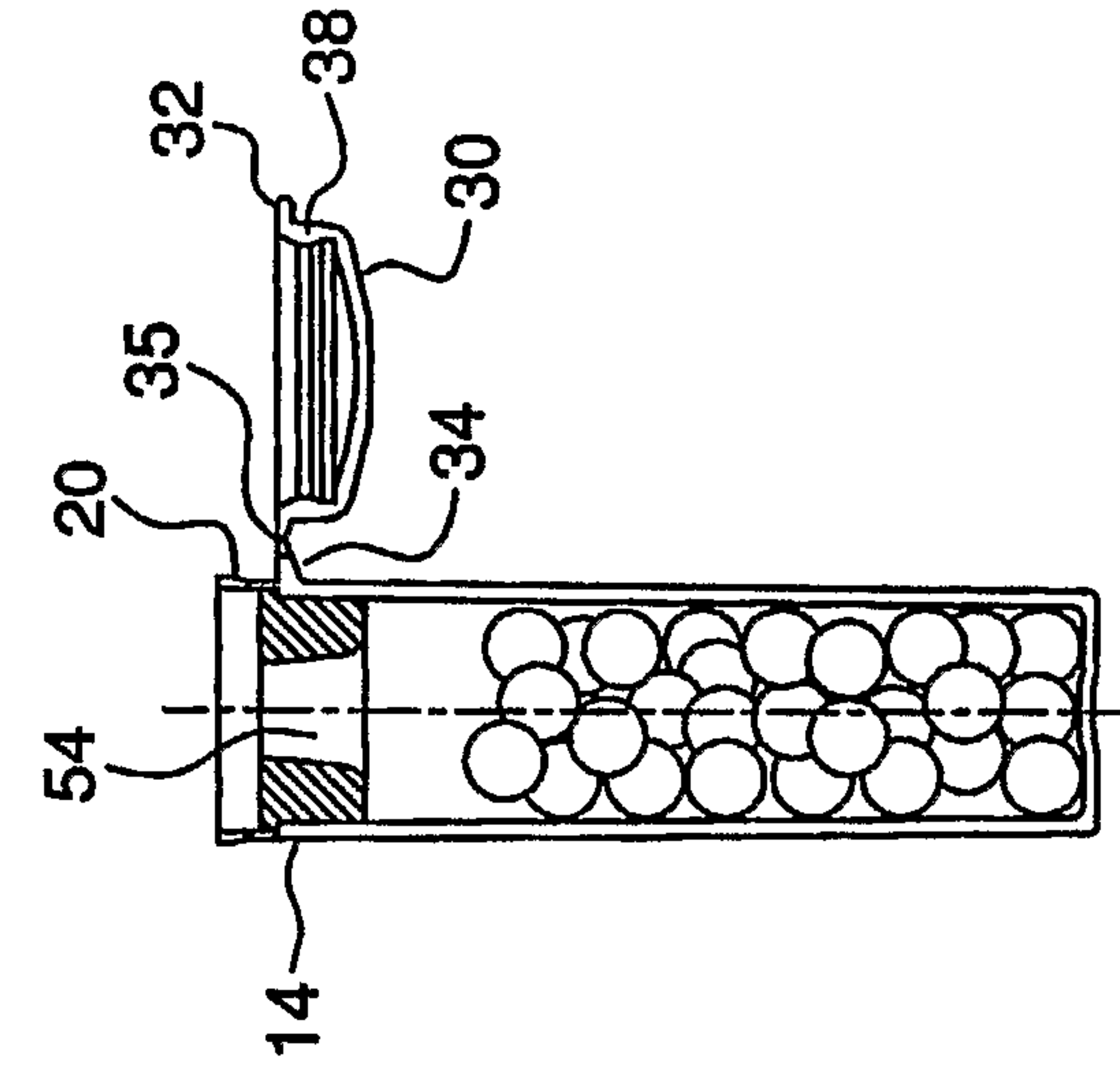
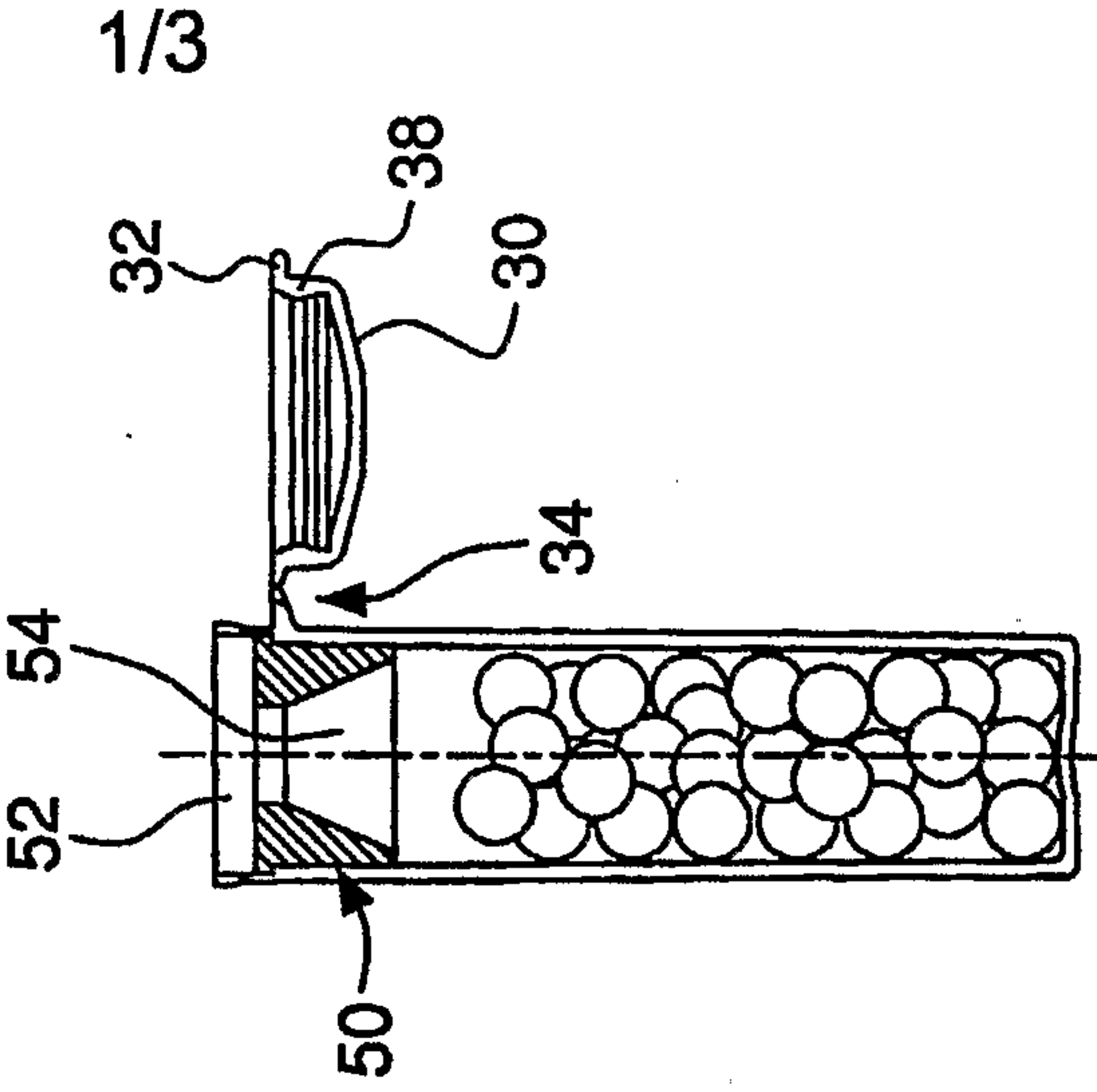

FIG. 3B



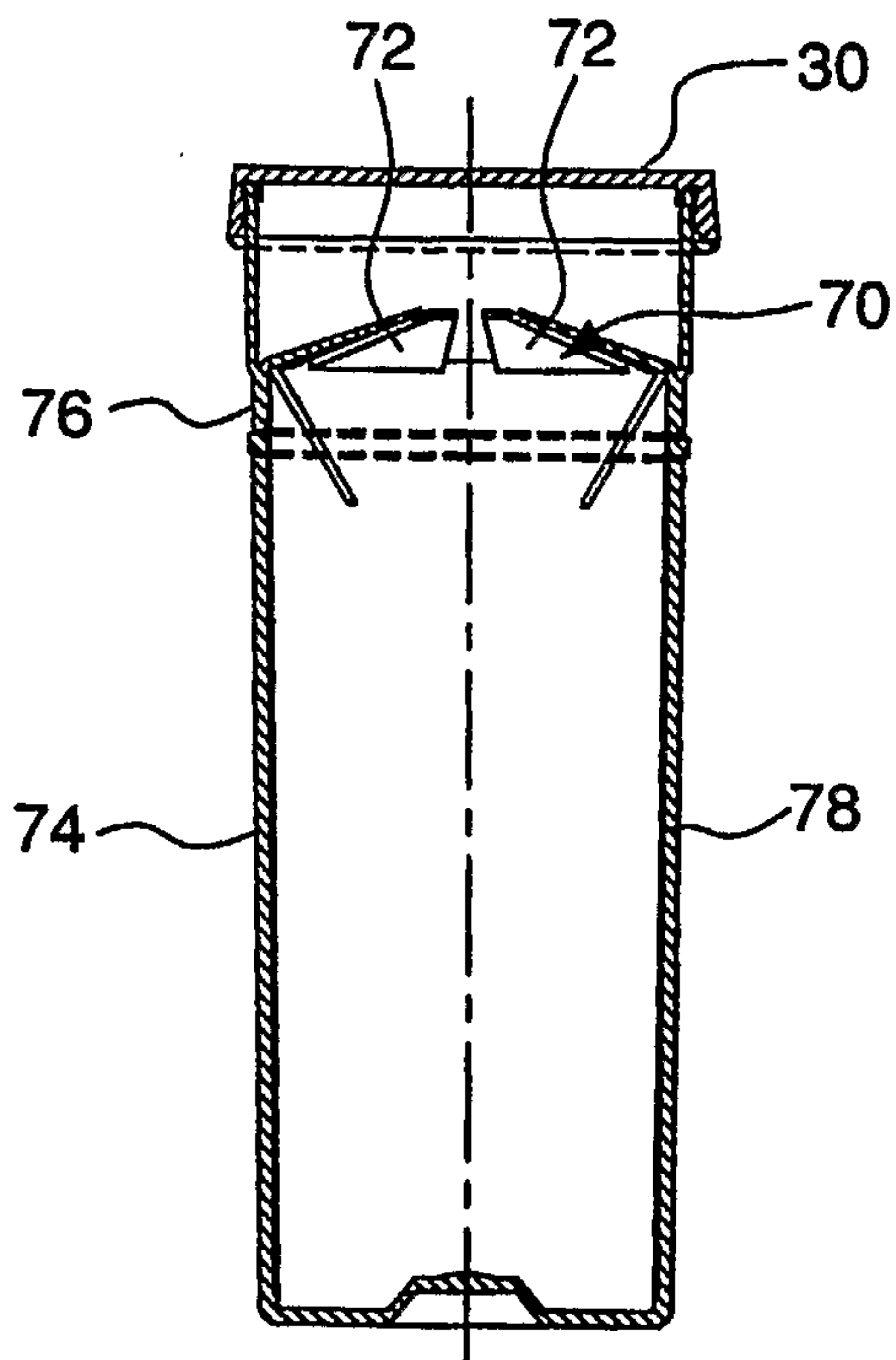

FIG. 4A

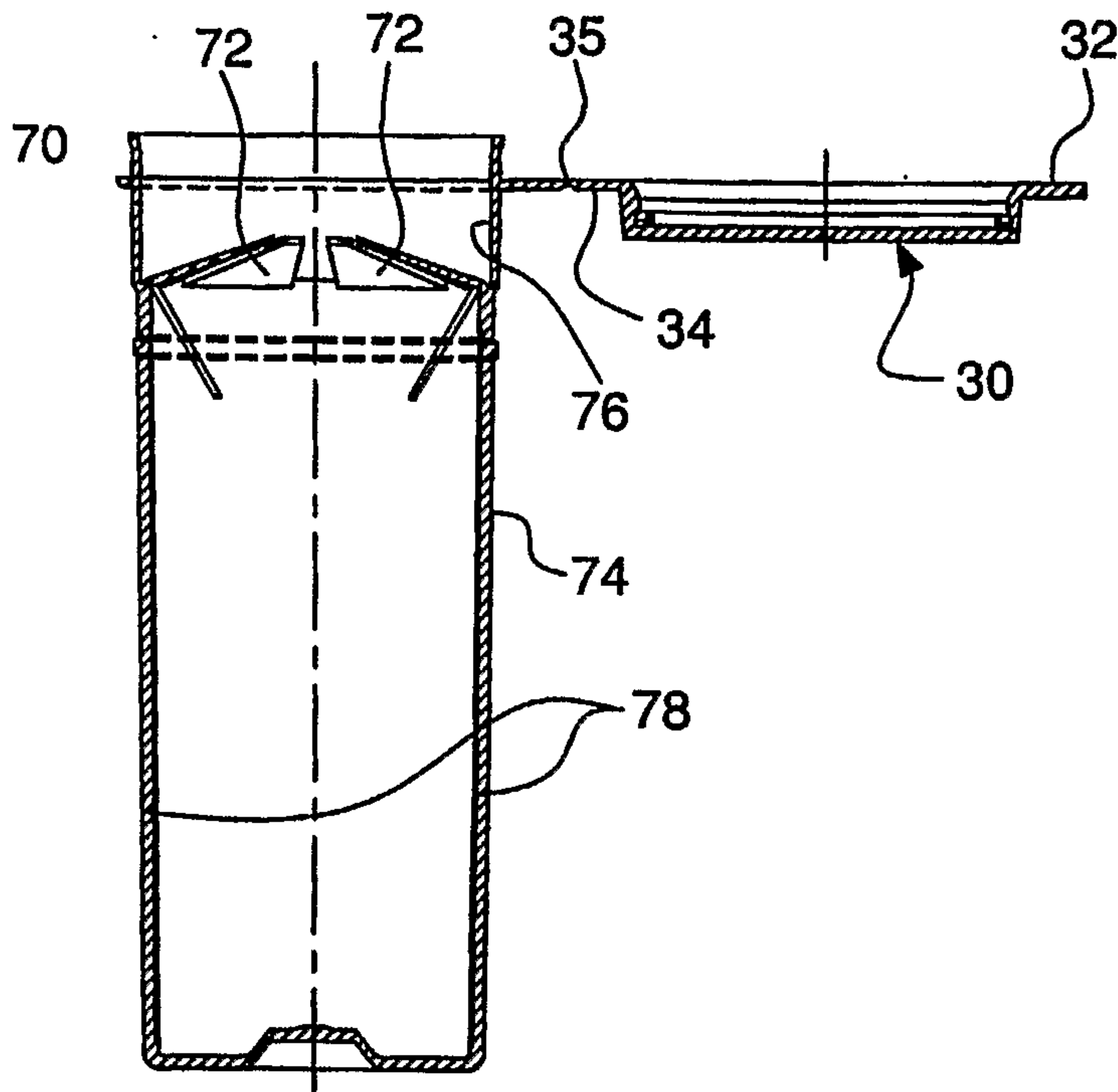

FIG. 4B

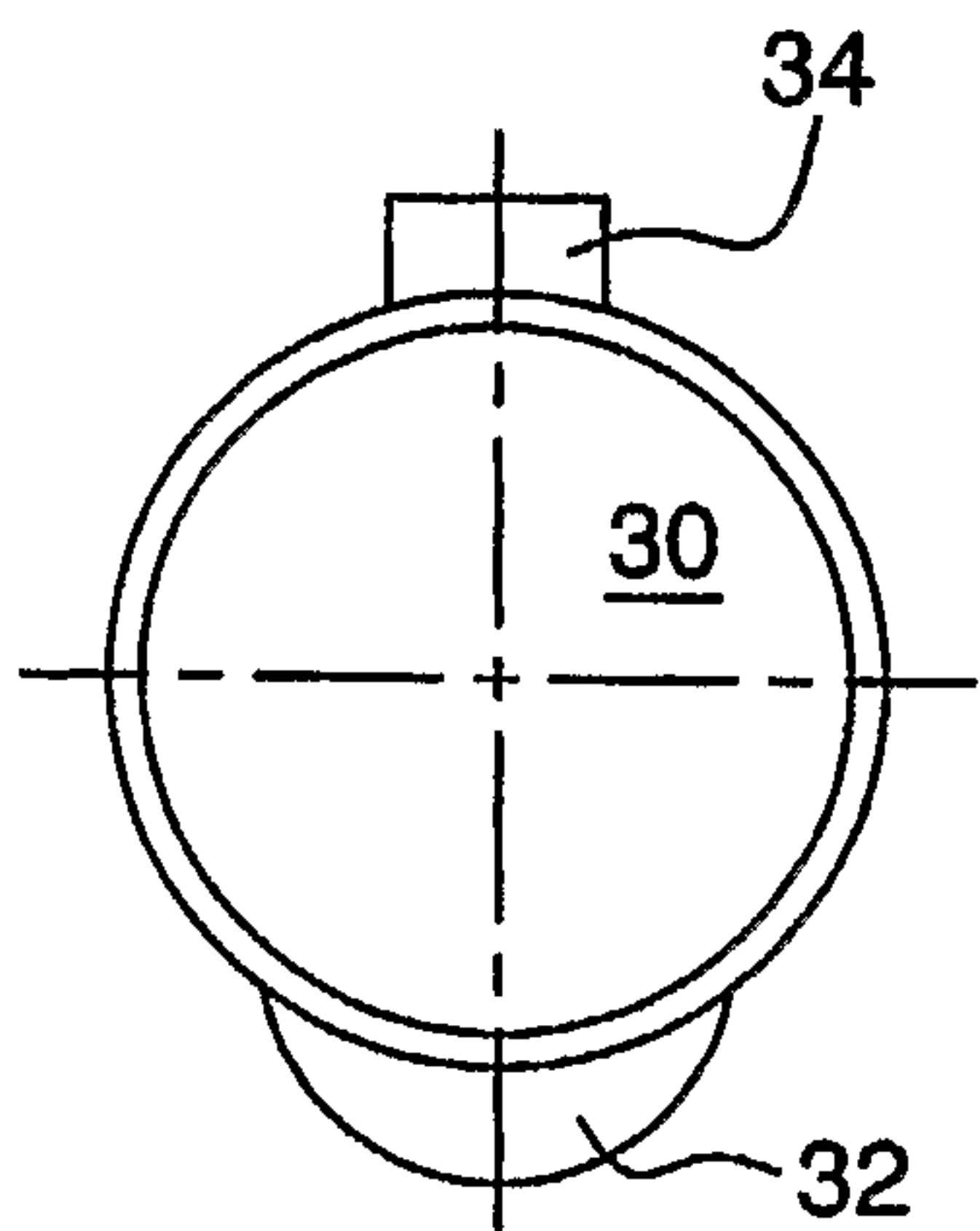

FIG. 5A

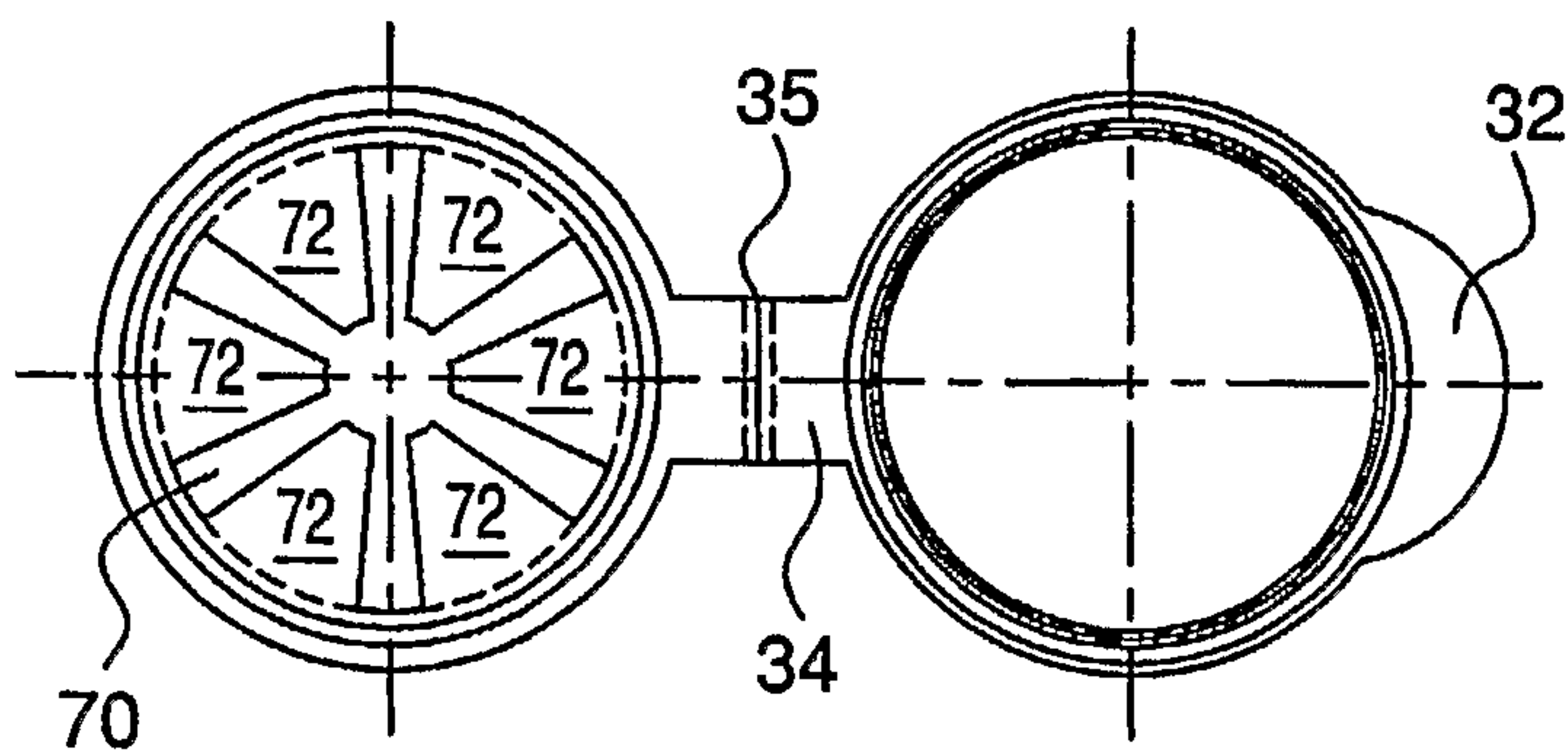

FIG. 5B

3/3

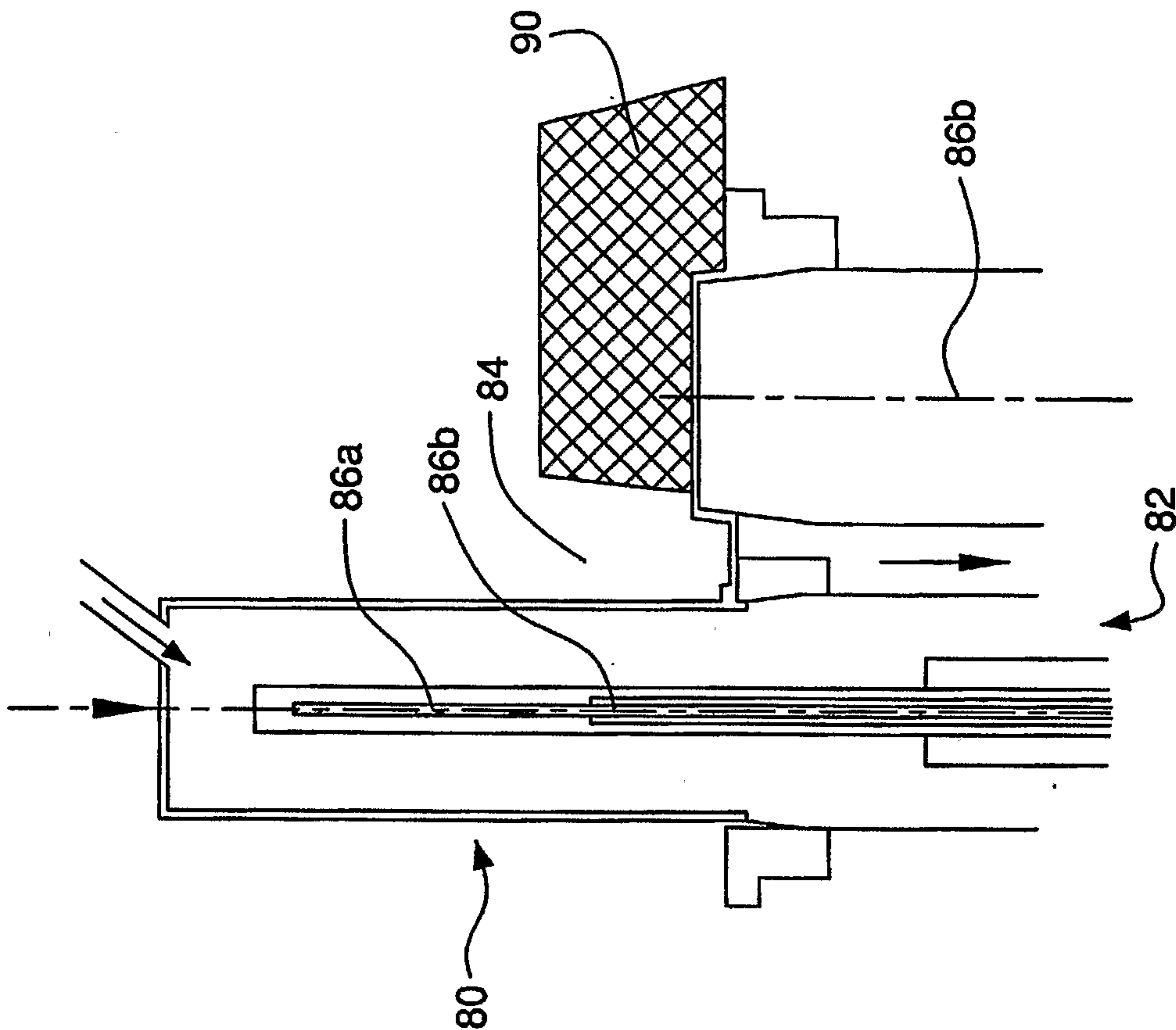

FIG. 6A

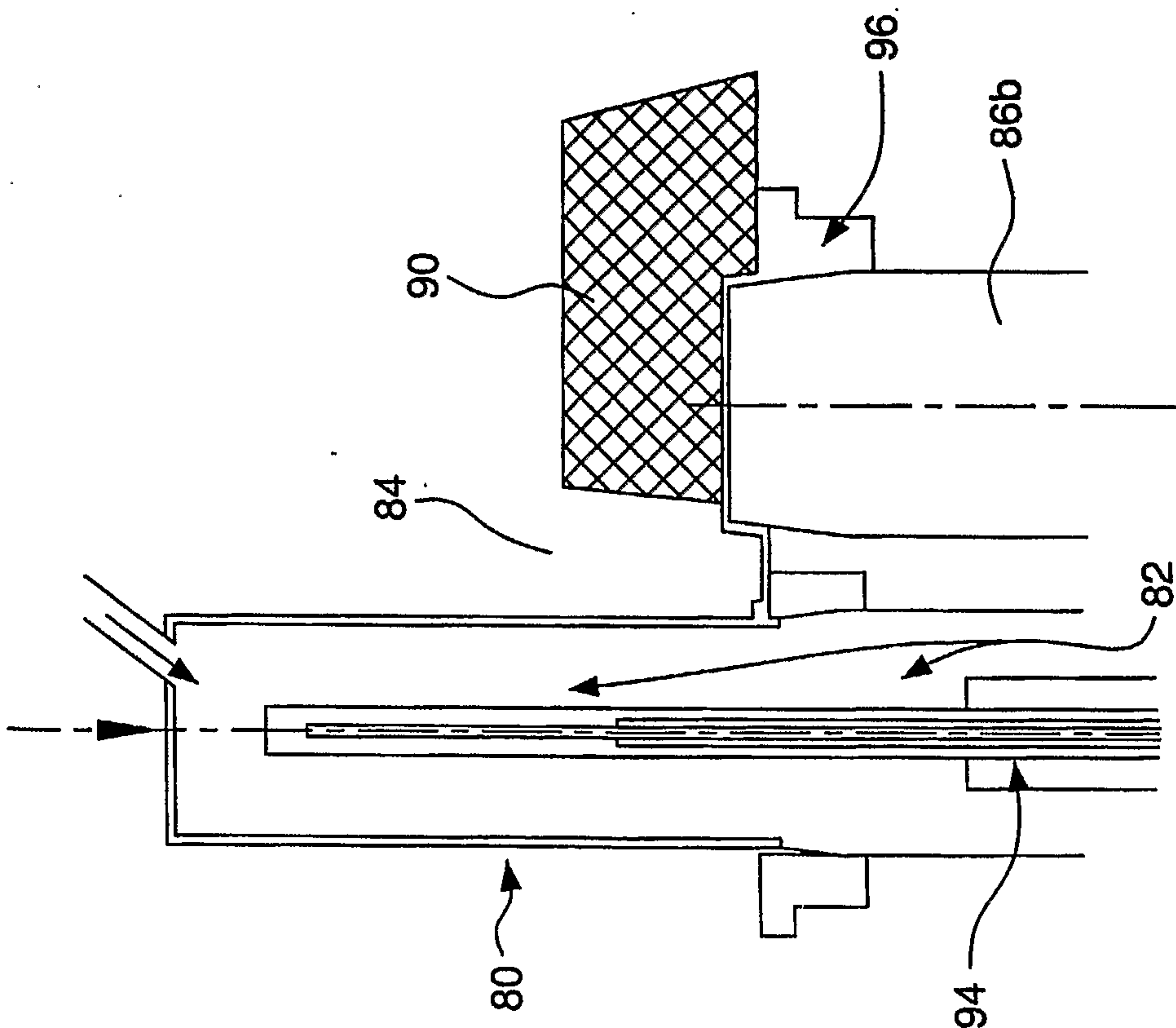

FIG. 6B

