

G. W. CHAFFIN.
 ELECTRIC INSULATOR.
 APPLICATION FILED FEB. 13, 1911.

998,073.

Patented July 18, 1911.

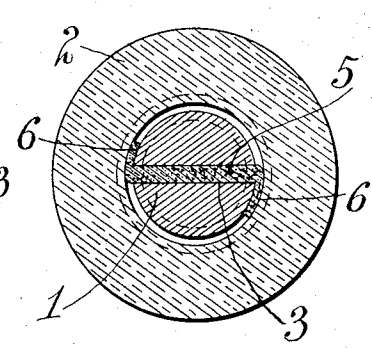
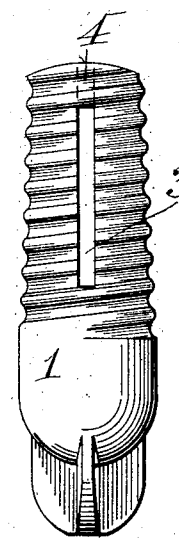
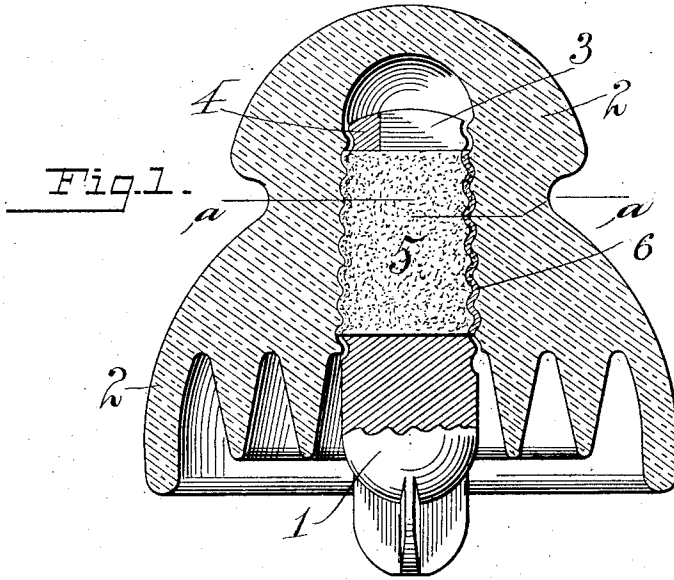

Fig. 5.

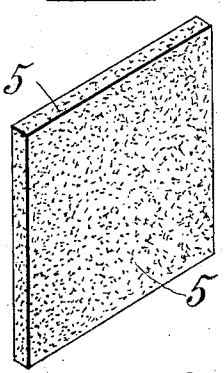

Fig. 2.

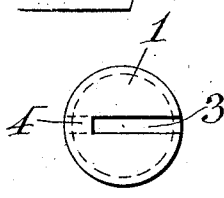

Fig. 4.

Fig. 3.

Geo. W. Chaffin
 Inventor

Witnesses
 W. Lubber
 J. P. Smith

384 R. J. McCarty
 his Attorney

UNITED STATES PATENT OFFICE.

GEORGE W. CHAFFIN, OF DAYTON, OHIO.

ELECTRIC INSULATOR.

998,073.

Specification of Letters Patent. Patented July 18, 1911.

Application filed February 13, 1911. Serial No. 608,191.

To all whom it may concern:

Be it known that I, GEORGE W. CHAFFIN, a citizen of the United States, residing at Dayton, in the county of Montgomery and State of Ohio, have invented certain new and useful Improvements in Electric Insulators; and I do declare the following to be a full, clear, and exact description of the invention, such as will enable others skilled in the art to which it appertains to make and use the same, reference being had to the accompanying drawings, and to the letters and figures of reference marked thereon, which form a part of this specification.

This invention relates to improvements in electric insulators of the kind used for stringing wires.

More specifically speaking the invention relates to the pin or support upon which the glass insulator is mounted. The said pin or support being of metal, of cast iron for example, and the insulator being of glass or similar material, it is important that the metallic pin or support shall have the quality of contracting as well as expanding under the different degrees of temperature in order that the glass insulator may be properly protected from breakage due to such changes in temperature.

It is the object, therefore, of this invention to so construct the pin or support that the same may have the necessary quality of expansion or contraction, and at the same time the structure of the metallic pin or support is not weakened to any extent that might impair its durability.

The accompanying drawings clearly illustrate my said improvements, and these will now be referred to and then a detailed description of said improvements will be given.

Figure 1 is a longitudinal vertical section of an insulator supported upon a pin constructed in accordance with my invention. Fig. 2 is a sectional view on the line *a-a* of Fig. 1. Fig. 3 is a longitudinal elevation of the cast iron plug or insulator support removed from the insulator. Fig. 4 is a view looking down upon the upper end of said pin, as shown in Fig. 3. Fig. 5 is a perspective view of a sheet of felt or similar soft substance which is used between the body of the metallic pin and the glass insulator to protect the latter.

In a detailed description of the inven-

tion, similar reference characters indicate corresponding parts.

The metallic pin 1 is, as before stated, constructed of cast iron, a portion of the body of which is provided with annular screw threads which engage similar screw threads of the glass insulator 2, and the two thus become united. The end of the pin 1 projecting from the insulator, is driven into the cross arm or other support (not shown). The manner of attaching the insulator supports is so well understood as to make it unnecessary to illustrate the cross arm or any other support to which the pin may be attached. The screw-threaded portion of the pin is cut, as at 3 from a point near the base of the pin through to the end of said pin on one side with a solid portion of the end of the pin left intact, as at 4. The metal thus removed in producing the cut 3, imparts to the portion of the pin inclosed by the insulator, the quality of expansion or contraction for substantially the length of that portion of the pin which engages the insulator. The leaving of the metal intact at one corner of the screw-threaded end affords a sufficient support for the sides of the pin thus separated by the cut-out portion to prevent any possible breakage of the pin owing to unusual pressure being exerted thereon. At the same time the portion of the pin supporting the glass insulator will have the necessary expanding and contracting quality to properly support the glass insulator and afford a sufficient protection. A sheet of felt 5 or similar material is passed through the opening 3 in the pin before said pin is inserted in the glass insulator. When the felt is thus passed through said opening, edges thereof extend beyond the sides of the pin, and when said pin is screwed into the insulator these edges lie between the glass insulator and the metal pin, as shown at 6 in Fig. 2, and thus provide cushions which protect the glass from direct contact with the pin.

Having described my invention, I claim:

1. A metallic supporting pin for insulators having a screw-threaded body portion provided with a longitudinal opening extending through the end thereof, the said opening being inclosed on one side at the end of the pin by a solid portion, whereby the effects of expansion are avoided and the desired strength of the pin is maintained, substantially as described.

2. A metallic screw-threaded supporting pin for insulators having a longitudinal opening 3 extending through the screw-threaded portion of said pin, said opening 5 being partially inclosed at the end of the pin by an integral portion 4, whereby elasticity and strength are combined in said pin, and a piece of yielding material lying within said opening and maintained therein

by the bridging portion 4, substantially as 10 specified.

In testimony whereof I affix my signature, in presence of two witnesses.

GEORGE W. CHAFFIN.

Witnesses:

R. J. McCARTY,
HOWARD S. SMITH.