

A. N. Woodard,

Belt Fastener.

No. 102074.

Patented Apr. 19. 1870.

Figure 1—

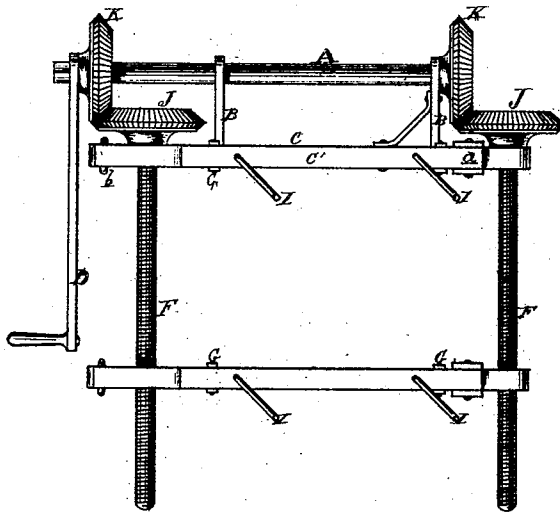
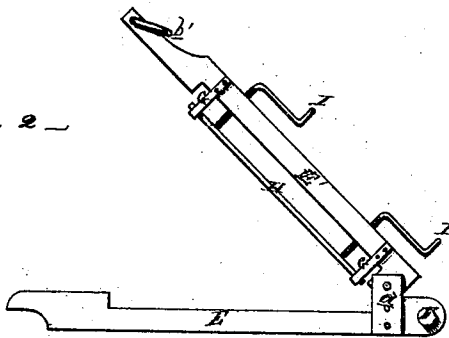

Figure 2—



ATTEST:

James Thierry
A. S. Sprague

INVENTOR:

Alvin W. Woodard
By Attorney
Thos. S. Sprague

United States Patent Office.

ALVIN N. WOODARD, OF FENTON, MICHIGAN.

Letters Patent No. 102,074, dated April 19, 1870.

IMPROVEMENT IN BELT-TIGHTENERS.

The Schedule referred to in these Letters Patent and making part of the same

To whom it may concern :

Be it known that I, ALVIN N. WOODARD, of Fenton, in the county of Genesee and State of Michigan, have invented a new and useful Improvement in Belt-Tighteners; and I do declare that the following is a true and accurate description thereof, reference being had to the accompanying drawings and to the letters of reference marked thereon and being a part of this specification, in which—

Figure 1 is a plan view of my device, and

Figure 2 is an elevation of the same from the rear side.

Similar letters of reference indicate corresponding parts in each figure.

The nature of this invention relates to an improvement in the construction of devices for taking up the slack in, or tightening belts, and holding the ends firmly together while being laced or otherwise joined.

It consists in a new and peculiar construction of the clamps for holding the ends of the belt, and their arrangement with relation to a pair of screws, and gearing for operating the same.

In the drawings—

A represents a shaft, properly journaled in brackets, B, projecting from the body of the clamp C, and is rotated by a crank, D.

C is a jaw forming the upper part of the clamp, to which it is hinged at *a*, at one end, and, when closed, is secured by a link, *b*, at the other, slipped over the end of the body of the clamp.

E is a similar clamp, provided in like manner with a jaw, *E'*, hinge *a'*, and link *b'*, and travels on the screws F, which are journaled in the ends of the clamps C.

G are stirrup-guides suspended from the under sides of the jaws C and E'.

H are clamp-plates loosely placed in said guides, and are forced against the belt to be operated upon by the screws I, the fabric being then firmly held between the body of the clamps and said plates.

J are pinions on the heads of the screws, which are rotated by miter-gears, K, on the shaft A, which mesh with them. Said screws being threaded in the ends of the clamp E, the latter is caused to approach or recede from the stationary clamp.

The movable clamp being at the ends of the screws the jaws are loosened and placed over the ends of the belts, the body of the clamps being on the under side. The clamps are then closed and secured by the links to the clamps, and the clamp-plates forced down by their screws. Then, by turning the crank, the movable clamp is caused to travel up the screws, bringing the ends of the belts together, when they are secured by lacing or otherwise.

What I claim as my invention, and desire to secure by Letters Patent, is—

1. In belt-tighteners, the clamps above described, constructed with the bed-pieces C and E, the hinged jaws C' and E', links *b* and *b'*, stirrup-guides G, clamp-plates H, and screws I, when arranged to operate as and for the purpose set forth.

2. The screws F, gears J and K, shaft A, and crank D, in combination with the clamps above described, constructed with the bed-pieces C and E, the hinged jaws C and E', links *b* and *b'*, stirrup-guides G, clamp-plates H, and screws I, when constructed and arranged to operate as and for the purposes set forth.

ALVIN N. WOODARD.

Witnesses:

H. A. WILLOVER,
A. J. HIRST.