



(22) Date de dépôt/Filing Date: 2006/10/30  
(41) Mise à la disp. pub./Open to Public Insp.: 2007/05/02  
(30) Priorité/Priority: 2005/11/02 (JP2005-319763)

(51) Cl.Int./Int.Cl. *F01P 5/10* (2006.01),  
*B60K 11/02* (2006.01), *F01P 3/00* (2006.01)

(71) Demandeur/Applicant:  
HONDA MOTOR CO., LTD., JP

(72) Inventeurs/Inventors:  
FUJIMOTO, YASUSHI, JP;  
ITO, KATSUHIKO, JP;  
MIZUNO, KINYA, JP;  
SOTANI, HIROSHI, JP;  
TAKAHASHI, MASAKO, JP

(74) Agent: DENNISON ASSOCIATES

(54) Titre : MOTEUR A COMBUSTION INTERNE REFROIDI PAR EAU  
(54) Title: WATER-COOLED INTERNAL COMBUSTION ENGINE

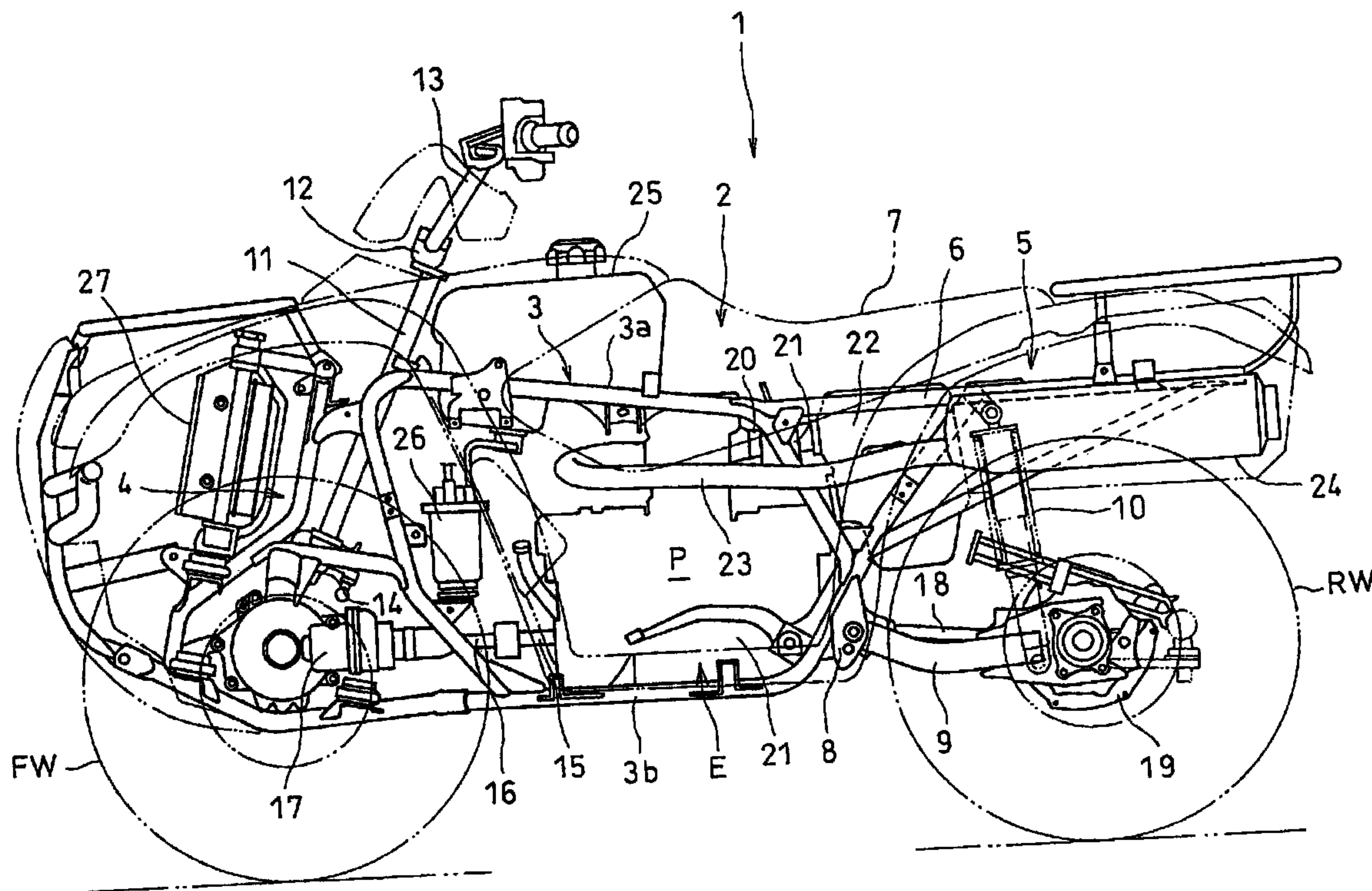

(57) Abrégé/Abstract:

A water-cooled internal combustion engine is provided which includes a water pump having a short pump drive shaft and thereby reduces the weight and size thereof. In a water-cooled internal engine E equipped with power transmission control means at the end of a crankshaft, a water pump having a water pump drive shaft parallel to the crankshaft is disposed on the axial inside of the power transmission control means, that is, on the central side of the crankshaft.

### **ABSTRACT OF THE DISCLOSURE**

A water-cooled internal combustion engine is provided which includes a water pump having a short pump drive shaft and thereby reduces the weight and size thereof. In a water-cooled internal engine E equipped with power transmission control means at the end of a crankshaft, a water pump having a water pump drive shaft parallel to the crankshaft is disposed on the axial inside of the power transmission control means, that is, on the central side of the crankshaft.

## WATER-COOLED INTERNAL COMBUSTION ENGINE

### FIELD OF THE INVENTION

- 5 The present invention relates to a water-cooled internal combustion engine provided on a crankshaft with power transmission controlling means such as a centrifugal type start clutch, a torque converter or the like.

### BACKGROUND OF THE INVENTION

- 10 For instance, Japanese Patent Laid-Open No. 2004-036584 discloses such a water-cooled internal combustion engine provided with power transmission controlling means on a crankshaft.

- 15 In the water-cooled internal combustion engine disclosed in Japanese Patent Laid-Open No. 2004-036584, a torque converter is provided on a near end of a crankshaft journaled on a crankcase and is covered by a crankcase cover from the axial outside.

- 20 In addition, a water pump having a pump drive shaft parallel to the crankshaft is provided on the crankcase cover.

- 25 Thus, since the water pump is located on the axial outside with respect to the torque converter, it protrudes toward the axial outside. This increases the axial width of the entire internal combustion engine to enlarge the size of the internal combustion engine. In addition, also this increases the length of the pump drive shaft of the water pump to increase the weight of the internal combustion engine.

The present invention has been made in view of the foregoing and it is an object of the invention to provide a water-cooled internal combustion engine that can reduce the length of the pump drive shaft of a water pump and also reduce the weight and size of the engine.

5

### **SUMMARY OF THE INVENTION**

In order to achieve the above object, the present invention is configured such that in a water-cooled internal combustion engine including: a crankshaft; power transmission control means disposed at an end of the crankshaft; and a water  
10 pump having a water pump drive shaft parallel to the crankshaft; the water pump is disposed on the axial inside of the power transmission control means, that is, on the central side of the crankshaft.

According to the water-cooled internal combustion engine of the present  
15 invention, since the water pump having the water pump drive shaft parallel to the crankshaft is disposed on the axial inside of the power transmission control means, that is, on the central side of the crankshaft; therefore, the water pump is disposed by using a dead space on the axial inside of the power transmission control means so that it does not project axially outwardly relative to the power  
20 transmission control means. This can downsize the internal combustion engine without expansion of the axial width of the entire internal combustion engine and also reduce the weight of the internal combustion engine while shortening the length of the pump drive shaft of the water pump.

25 An aspect of the invention is characterized in that in the water-cooled internal combustion engine according to the above, the water pump axially overlaps the power transmission control means.

According to this aspect of the water-cooled internal combustion engine of the  
30 present invention, since the water pump partially axially overlaps the power transmission control means, the water pump is disposed to be close to the crankshaft, which further downsizes the internal combustion engine.

Another aspect of the invention is characterized in that in the water-cooled internal combustion engine according to the above, an oil tank is disposed on the axial outside of the power transmission control means.

5 According to this aspect of the water-cooled internal combustion engine of the present invention, since the oil tank is disposed on the axial outside of the power transmission control means, the capacity of the oil tank can be sufficiently ensured by utilizing the wide area on the axial outside of the power transmission control means while reducing the axially outward expansion of the oil tank.  
10 Thus, in the internal combustion engine equipped integrally with the oil tank, the entire internal combustion engine can be downsized, thereby improving its mounting performance on the body frame.

A further aspect of the invention is characterized in that in the water-cooled  
15 internal combustion engine according to the above, an outer end of the water pump is supported by an engine cover whose part constitutes the oil tank.

According to this aspect of the water-cooled internal combustion engine of the present invention, since an outer end of the water pump is supported by an  
20 engine cover whose part constitutes the oil tank, the water pump can be fastened to the engine cover without use of the special member. This reduces the number of part components and provides satisfactory assembly workability.

Yet another aspect of the invention is characterized in that in the water-cooled  
25 internal combustion engine according to the above, the outer end of the water pump serves as a cooling water-sucking nozzle which projects on the axial outside.

According to this aspect of the water-cooled internal combustion engine of the present invention, the outer end of the water pump serves as a cooling water-sucking nozzle which projects on the axial outside and is supported by the  
30 engine cover, which provides satisfactory assembly workability.

**BRIEF DESCRIPTION OF THE DRAWINGS**

Preferred embodiments of the invention are shown in the drawings, wherein:

5 Fig. 1 is a side view of an all terrain vehicle, with a body cover removed, on which a water-cooled internal combustion engine according to an embodiment of the present invention.

Fig. 2 is a plan view of Fig. 1.

10 Fig. 3 is a front view of a power unit with the internal combustion engine partially omitted.

Fig. 4 is a cross-sectional view illustrating an essential portion of the internal combustion engine.

15

Fig. 5 is a front view of a front crankcase.

Fig. 6 is a front view of a spacer.

20 Fig. 7 is a rear view of the spacer.

Fig. 8 is a cross-sectional view of the spacer taken along line VIII-VIII of Fig. 6.

Fig. 9 is a cross-sectional view of the spacer taken along line IX-IX of Fig. 6.

25

Fig. 10 is a cross-sectional view of the spacer taken along line X-X of Fig. 7.

Fig. 11 is a front view of a water pump cover.

30 Fig. 12 is a rear view of Fig. 11.

Fig. 13 is a front view of a crankcase cover.

Fig. 14 is a cross-sectional view of the crankcase cover taken along line XIV-XIV of Fig. 13.

Fig. 15 is a front view of an oil tank cover.

5 Fig. 16 is a cross-sectional view of the oil tank cover taken along line XVI-XVI of Fig. 15.

### **DETAILED DESCRIPTION OF THE PREFERRED EMBODIMENTS**

10 An embodiment of the present invention will be hereunder described with reference to Figs. 1 through 16.

15 Figs. 1 and 2 are a side view and a plan view, respectively, illustrating an all terrain vehicle 1 on which a water-cooled internal combustion engine E according to the embodiment is mounted with its body cover and the like removed.

Note that the front, rear or back, left and right are determined based on the vehicle that faces the forward.

20 The all terrain vehicle 1 is a baggy type four-wheeled vehicle and includes a pair of left and right front wheels FW and a pair of left and right rear wheels RW suspended by the front portion and rear portion, respectively, of a body frame 2. The front and rear wheels each have a low-pressure balloon tire for irregular ground, attached thereto.

25

The body frame 2 is configured by joining a plurality of types of steel members together and has a center frame portion 3, a front frame portion 4 and a rear frame portion 5. The center frame portion 3 mounts thereon a power unit P integrally composed of an internal combustion engine E and a transmission T in a crankcase 31. The front frame portion 4 is joined to the front part of the center frame portion 3 to suspend the front wheels WF. The rear frame portion 5 is joined to the rear part of the center frame portion 3 and includes seat rails 6 supporting a seat 7.

30

The center frame portion 3 is formed about-rectangular as viewed from the side by bending downwardly a front and a rear part of each of a pair of left and right upper pipes 3a to form about three sides and connecting the front part and rear part through the remaining side, i.e., a corresponding one of a pair of left and right lower pipes 3b. The left and right pipes are connected by cross members.

A pivot plate 8 is secured to an extension of the rear part of the lower pipe 3b that bends obliquely upward. The front end of a swing arm 9 is swingably supported via a shaft by the pivot plate 8. A rear cushion 10 is interposed between the rear part of the swing arm 9 and the rear frame portion 5. The rear wheel RW is suspended by a rear final reduction gear unit 19 provided at the rear end of the swing arm 9.

A steering column 11 is supported by the widthwise center part of a cross member spanned between the front ends of the left and right upper pipes 3a. A steering handlebar 13 is joined to the upper end of a steering shaft 12 steerably supported by the steering column 11. The lower end of the steering shaft 12 is connected to a front wheel steering mechanism 14.

The internal combustion engine E of the power unit P is a water-cooled single cylinder internal combustion engine and is mounted on the center frame portion 3 in the so-called longitudinally-mounted posture in which the crankshaft 30 is directed in the back-and-forth direction of the vehicle body.

The transmission T of the power unit P is disposed on the left side of the internal combustion engine E. An output shaft 15 directed in the back-and-forth direction from the transmission T offset leftward projects backward and forward. The rotary power of the output shaft 15 is transmitted from the front end of the output shaft 15 to the left and right front wheels FW via a front drive shaft 16 and a front final rear reduction gear unit 17. Similarly, the rotary power of the output shaft 15 is transmitted from the rear end of the output shaft 15 to the left and right rear wheels RW via the rear drive shaft 18 and the rear final reduction gear unit 19.

The internal combustion engine E rises so as to slightly tilt leftward by placing a cylinder block 32, a cylinder head 33 and a cylinder head cover 34 on the crankcase 31 on this order.

- 5 An intake pipe 20 extending rearward from the cylinder head 33 is connected to an air cleaner 22 via a throttle body 21. An exhaust pipe 23 extending forward from the cylinder head 33 bends leftward, extends rearward, passing the left side of the air cleaner 22, and joins to an exhaust muffler 24.
- 10 A fuel tank 25 is mounted on the center frame portion 3 of the body frame 2 so as to be located above the power unit 25. A fuel pump 26 is disposed forward of and below the fuel tank 25. A radiator 27 is supported by the front frame portion 4 of the body frame 2.
- 15 The crankcase 31 incorporating the internal combustion engine E and transmission T of the power unit P is configured to be divided into a front portion and a rear portion, that is, a front crankcase 31F and a rear crankcase 31R, at a plane orthogonal to the crankshaft 30 passing the central axis of the cylinder bore of the cylinder block 32 and extending in the back-and-forth  
20 direction of the vehicle body.

Fig. 3 is a front view of the power unit P, illustrating a mating surface 31Rf of the rear crankcase 31R with the internal combustion engine E partially omitted.

- 25 A cylinder sleeve 32a is fitted into the crankcase 31 from the cylinder block 32 and a piston 35 is slidably fitted into the cylinder sleeve 32a.

- A crank pin 37 spanned between a pair of front and rear crank webs 30w, 30w of the crankshaft 30 is connected to a piston pin 36 attached to the piston 35 by a  
30 connecting rod 38.

Fig. 4 is a cross-sectional view of an essential part of the internal combustion engine E.

As shown in Fig. 4, the crankshaft 30 is journaled by the front crankcase 31F and the rear crankcase 31R via main bearings 39, 39 in front and rear of the crank webs 30w, 30w, respectively.

- 5 A balancer shaft 40 is disposed on the right of (on the left of, in Fig. 3), slightly below and in parallel to the crankshaft 30. The balancer shaft 40 is journaled at both ends thereof by the front crankcase 31F and the rear front crankcase 31R via bearings 41, 41.
- 10 A balancer weight 40w is formed at the center of the balancer shaft 40. A driven gear 42b is fittingly attached to a rear portion of the balancer weight 40w so as to mesh with a drive gear 42a fittingly attached to the crankshaft 30 (see Fig. 4).

- 15 A valve system cam shaft 43 is disposed on the right of, obliquely above and in parallel to the crankshaft 30. The cam shaft 43 is journaled at both ends thereof by the front crankcase 31F and the rear crankcase 31R via bearings 44, 44.

- 20 The lower end of a push rod 45 is in abutment against cam lobes 43a, 43b of the cam shaft 43 so as to transmit a driving force to a valve mechanism in the cylinder head 33.

- 25 On the left of (on the right of, in Fig. 3) the crankshaft 30, is disposed the transmission T in which a main shaft 46, a counter shaft 47 and an intermediate shaft 48 constitute a speed change gear mechanism. Shift transmission is executed by driving a shift drum 49 whereby power is transmitted to the output shaft 15.

- 30 A rear side mating surface 31Fr of a front crank case 31F depicted in Fig. 5 is superposed on and fastened to a front side mating surface 31Rf of the rear crankcase 31R depicted in Fig. 3. The crankcase 31 is configured by accommodating therein the crank webs 30w of the crankshaft 30, the balancer weight 40w of the balancer shaft 40, the cam lobes 43a, 43b of the camshaft 43 and like and the transmission T.

The front crankcase 31F is formed with: a circular hole 31Fa to which the main bearing 39 is fittingly attached and through which the crankshaft 30 passes; a circular hole 31Fb to which the bearing 44 is fittingly attached and through which the cam shaft 43 passes; a circular hole 31Fc through which the main shaft 46 passes; and a circular hole 31Fd through which the output shaft 15 passes (see Fig. 5).

As shown in Fig. 4, a connection sleeve 51 provided with a driven sprocket 52 is fittingly attached to the front end of the cam shaft 43 which protrudes forwardly from the front crankcase 31F. A chain 53 is spanned between a drive sprocket 30s formed on the crankshaft 30 and the driven sprocket 52 so that rotation of the crankshaft 30 is transmitted to the camshaft 43 via the chain 53 (refer to two-dot chain lines in Figs. 4 and 5).

On the front side of a portion of the front crankcase 31F adapted to accommodate the balancer shaft 40 therein and below the chain 53, an oil pump unit 60 of a dry sump type lubricating system is internally attached to an annular side wall which forms the front side mating surface 31Ff. Fig. 5 depicts a state in which the oil pump unit 60 is attached.

As shown in the cross-sectional view of Fig. 4, the oil pump unit 60 is configured such that a front oil pump case 61F and a rear oil pump case 61R put a partition wall 61a therebetween and oil passages 62f and 62r are formed in front and rear, respectively, of the partition wall 61a. A pump drive shaft 63 passes, in the back-and-forth direction, through the front oil pump case 61F, the partition wall 61a and the rear oil pump case 61R and is journaled coaxially with the balancer shaft 40. The rear end of the pump drive shaft 63 further passes through the front crankcase 31F and is coupled to the balancer shaft 40 for integral rotation.

A feed pump 64 and a scavenge pump 65 are provided in the oil passages 62f and 62e in front and rear, respectively, of the pump drive shaft 63.

In addition, a relief valve 66 capable of communicating with the front and rear oil passages 62f, 62r is supported by the partition wall 61a to pass therethrough.

An upstream inflow nozzle 62ru projects rearward of the rear side oil passage 62r and is joined to an oil passage 31o communicating with a strainer (not shown) provided in the crankcase 31. A downstream side outflow nozzle 62rl (see Fig. 5) projecting forward of the oil passage 62r communicates with an inflow passage 123a (see Fig. 13) of an oil tank 120 formed in a crankcase cover 100 described later.

An upstream side inflow nozzle 62fu projecting forward of the front side oil passage 62f communicates with an outflow passage 123b (see Fig. 13) of the oil tank 120 formed in the crankcase cover 100. Similarly, a downstream side outflow nozzle 62fl projecting forwardly communicates with an inflow passages 113a (see Fig. 13) of an oil filter 110 formed in the crankcase cover 100.

Thus, when the scavenge pump 65 and the feed pump 64 are rotated together with the pump drive shaft 63 rotating coaxially and integrally with the balancer shaft 40, the scavenge pump 65 sucks in the oil accumulating on the bottom of the crankcase 31 via the strainer and discharges it to the oil tank 120. In addition, the feed pump 64 sucks in the oil from the oil tank 120 and feeds it to every part to be lubricated through the oil filter 120.

In this way, the oil pump unit 60 and the like are attached to the front side of the front crankcase 31F and the crankcase cover 100 covers the front of the oil pump unit 60 and the like. In addition a spacer 70 is interposed between the front crankcase 31F and the crankcase cover 100.

The spacer 70 is adapted to connect the front crankcase 31F and the crankcase cover 100, is formed with front and rear mating surfaces 70f, 70r parallel to each other and has a substantially constant back-and-forth width. In addition, as shown in Fig. 6, the spacer 70 is an annular member that has a large internal cavity 72 defined by a circumferential wall 71 corresponding to the annular front side mating surface 31Ff of the crankcase 31F. The cavity 72 corresponds to the periphery of the crankshaft 30, the main shaft 46, the output shaft 15 and the like and a region adapted to accommodate the oil pump unit 60 therein.

5 A water pump body 81 of a water pump 80 is formed to protrude inwardly from the circumferential wall 71 of the spacer 70 at a portion, corresponding to the cam shaft 43, located on the right-hand upper corner of the circumferential wall 71.

10 The water pump body 81 includes a large diameter flat cylindrical part 81a opening forwardly and centrally coaxially with the cam shaft 43, a reduced-diameter cylinder part 81b rearward thereof, a further-reduced-diameter cylinder part 81c and a furthermore-reduced-diameter cylinder part 81d, which extend rearward sequentially stepwise (refer to Figs. 4 and 7).

15 As shown in Fig. 6, a halved-annular water passage 82a is formed inside the large diameter flat cylindrical part 81a and part of the halved-annular water passage 82a extends tangentially to form a halved-discharge water passage 82b. The halved-annular water passage 82a and the halved-discharge water passage 82b are open forwardly and its opening end face 82f is closed-annular and flush with the front mating surface 70f of the spacer 70.

20 A water pump cover 95 is provided with a mating surface having the same shape as that of the opening end face 82f as a mating surface and is covered on the opening end face 82 from the forward.

25 The discharge water passage 82c extends rearward from the leading end of the halved-discharge water passage 82b and communicates with a discharge water passage 31Fw (see Fig. 5) formed in the front crankcase 31F. Thus, cooling water is supplied from the front crankcase 31F to to-be-cooled portions of the cylinder block 32 and cylinder head 33.

30 A drain passage 83 is bored to tilt slightly upwardly from the right-hand wall of the spacer 70 toward the lower portion of the halved-annular water passage 82a. A drain bolt 84 threads into the outside opening of the drain passage 83 (see Figs. 6 and 8).

Further, a breather passage 85 is bored from the right-hand wall of the spacer 70 toward the inner lower portion of the cylindrical part 81b of the water pump body 81 so as to tilt slightly upwardly in parallel to the drain passage 83. One end of the breather tube 86 is fitted into the outside opening of the breather passage 85 (see Figs. 6 and 8). The breather tube 86 bends downwardly to direct the opening of the other end thereof toward the downside.

A left-hand portion of the circumferential wall 71 of the spacer 70 is tilted with respect to the axial direction to cover the rearward from the front side. An attachment boss part 74 is formed on the upper portion of the tilted circumferential wall 71 to support an oil level gauge 75 by screwing it into the threaded hole 74a thereof (see Fig. 10).

Referring to Fig. 6, the oil level gauge 75 is inserted into the threaded hole 74a of the attachment boss part 74 from outside and obliquely above the circumferential wall 71 of the spacer 70. The oil level gauge 75 is attached by engaging the thread formed on the near proximal end thereof with the threaded hole 74a. The distal end of the oil level gauge 75 reaches the inner near bottom of the circumferential wall 71 included in the spacer 70 so that it can detect the amount of oil accumulating on the bottom.

As shown in Fig. 4, a cylindrical water pump drive shaft 87 is inserted into the cylindrical parts 81b, 81c, 81d of the water pump body 81 included in the water pump 80. Specifically, this drive shaft 87 is rotatably journaled by the cylindrical part 81d. A water seal member 88 is fitted into the inside of the cylindrical part 81b and an oil seal member 89 is fitted into the cylindrical part 81c, thus providing a dual seal structure.

Incidentally, the breather passage 85 is open between the water seal member 88 inside the cylindrical part 81d and the oil seal member 89.

The pump drive shaft 87 is partially formed with a slightly diameter-enlarged protruding part 87a. The pump drive shaft 87 is inserted from the rearward of the water pump body 81 to the cylindrical part 81d so that the protruding part

87a comes into abutment against the rear end face of the cylindrical part 81d via a washer 90. This will limit the axially forward movement of the pump drive shaft 87.

5 The rear end of the pump drive shaft 87 is inserted inside the connection sleeve 51 fixedly secured to the front end of the cam shaft 43 coaxial with the pump drive shaft 87. A pin 91 attached radially to the connection sleeve 51 is fitted into a notch 87b formed at the rear end of the pump drive shaft 87. Thus, rotation of the connection sleeve 51 is transmitted to the pump drive shaft 87 via the pin 91.

10

An impeller 92 is fittingly attached to the front end of the pump drive shaft 87 projecting along the center of the large-diameter flat cylindrical part 81a of the water pump body 81. Thus, the halved annular water passage 82a of the flat cylindrical part 81a is formed around the impeller 92.

15

A water pump cover 95 is superposed on a front opening defined by the halved annular water passage 82a and halved discharge water passage 82b of the water pump body 81 so as to cover the impeller 92.

20

As shown in Figs. 11 and 12, a cover body portion 95a of the water pump cover 95 is formed with: a halved annular water passage 96a facing the halved annular water passage 82a of the water pump body 81; and a halved discharge water passage 96b facing the halved discharge water passage 82b of the water pump body 81. In addition, an opening end surface 95r opening on the rearward of the

25 halved annular water passage 96a and the halved discharge water passage 96b faces the opening end surface 82f of the water pump body 81. Thus, the opening end face 95r and the opening end face 82f each serve as a mating surface for the counterpart.

30

In the water pump cover 95, the bottom wall portion of the halved annular water passage 96a included in the cover body portion 95a extends toward the center thereof and then its central portion projects forwardly to form a cover cylindrical portion 95b or a cooling water sucking nozzle (see Fig. 4).

A seal member 97 is fitted into an annular groove formed in the opening end face 95r of the water pump cover 95 (see Fig. 12). When the water pump cover 95 is placed on the water pump body 81 from the front, the opening end face 95f of the water pump cover 95 is superposed on the opening end face 82f of the water pump body 81 via the seal member 97. Then, the water pump cover 95 is fastened by means of bolts 98.

The center shaft of the cover cylindrical portion 95b of the water pump cover 95 is coaxial with the pump drive shaft 87.

When the pump drive shaft 87 is rotated together with the cam shaft 43 and the impeller 92 is rotated, cooling water is sucked from the cover cylindrical portion 95b of the water pump cover 95, directed into the annular water passages 82a, 96a by a centrifugal force and then discharged from the discharge water passages 82b, 96b.

The water pump 80 is configured such that the water pump body 81 is formed in the spacer 70 and the water pump cover 95 separate from the water pump body 81 protrudes forwardly from the spacer 70.

A shift clutch 55 is provided on a portion of the main shaft 46 that projects forwardly from the front crankcase 31F and that is located in the cavity 72 of the spacer 70. Although the shift clutch 55 extends slightly forwardly from the mating surface 70f of the spacer 70, it is generally fitted in the cavity 72 of the spacer 70 (see Fig. 6).

The crankshaft 30 projects forwardly from the front crankcase 31F, passing through the cavity 72 of the spacer 70, and further projects to a position near the front end of the cover cylindrical portion 95b of the water pump cover 95 included in the water pump 80. A centrifugal type start clutch 56, that is power transmission controlling means, is provided on the projection of the crankshaft 30 that is located at a portion roughly corresponding to the cover cylindrical portion 95b.

- With reference to Fig. 4, the centrifugal type start clutch 56 includes a clutch inner 56i or an input member rotated together with the crankshaft 30; a bowl-like clutch outer 56o or an output member enclosing the clutch inner 56i from the radial outside; and a clutch shoe 56s or a centrifugal weight that is pivotally supported by the clutch inner 56i, is moved radially outwardly by a centrifugal force and comes into contact with the clutch outer 56o for engagement. The boss portion of the clutch outer 56o is spline fitted to the cylindrical gear member 57 rotatably carried on the clutch shaft 30.
- 10 A drive gear 57a of the cylindrical gear member 57 meshes with a driven gear (not shown) on the side of the shift clutch 55.
- The centrifugal type start clutch 56 is expanded in the radial direction of the crankshaft 30 at a position forward of the front mating surface 70f of the spacer 15 70. The cover body portion 95a of the water pump cover 95 and water pump body 81 of the water pump 80 partially overlap the clutch outer 56o of the centrifugal type start clutch 56 in the axial direction and are located on the rear side of the clutch outer 56o (on the central side of the crankshaft).
- 20 That is to say, the water pump 80 is located on the axially inside of the centrifugal type start clutch 56 provided on the front end of the crankshaft 30, i.e., on the central side of the crankshaft 30 and disposed by using the dead space on the axial inside of the centrifugal type start clutch 56. Therefore, the water pump 80 does not project axially outwardly from the centrifugal type start clutch 25 56. Consequently, the internal combustion engine E can be downsized without increasing the axial width of the entire internal combustion engine E and can be reduced in weight by shortening the length of the pump drive shaft 87 of the water pump 80.
- 30 In addition, since the water pump 80 is designed to partially overlap the centrifugal type start clutch 56 in the axial direction, it is disposed to be close to the crankshaft 30, thereby further downsizing the internal combustion engine E.

In this way, the crankcase cover 100 covers, from the front, the centrifugal type start clutch 56 and the water pump cover 95 of the water pump 80 which project forwardly from the front mating surface 70f of the spacer 70.

5 The crankcase cover 100 has a mating surface 100r corresponding to the front mating surface 70f of the spacer 70 and a front wall 101 inside the annular mating surface 100r is formed to protrude forwardly (see Fig. 14). The centrifugal type start clutch 56 and the shift clutch 55 is accommodated in this protruding space 102.

10

As shown in Fig. 14, the front wall 101 is formed with a bearing hole 101a adapted to journal the front end of the crankshaft 30 via a bearing 106 and with a bearing hole 101b adapted to journal the front end of the main shaft 46 via a bearing (not shown).

15

The crankcase cover 100 is formed at a portion thereof corresponding to the water pump 80 with a connection cylindrical portion 103 which faces the axial direction so that the cover cylindrical portion 95b of the water pump cover 95 can be fittingly inserted into the connection cylindrical portion 103.

20

The cover cylindrical portion 95b of the water pump cover 95 is fitted into the rear half part of the connection cylindrical portion 103 via seal members 108, 109 (see Fig. 4). Connection pipes 104 and 105 are fixedly fitted into the front half portion of the connection cylindrical portion 103 from the front and the side, 25 respectively (see Figs. 4 and 14).

25

The connection pipe 104 is attached in a manner not-coaxial with but offset from the central axis of the connection cylindrical portion 103. This is because, when a hose extending from the radiator 27 is coupled to the connection pipe 104, the connection pipe 104 is prevented from interfering with the circumferential wall 122a of an oil tank cover 122 described later.

30

The other connection pipe 105 is coupled to a hose extending from a thermostat (not shown).

Thus, with the switching of the thermostat, cooling water is directly sucked in the water pump 80 from the thermostat not via the radiator 27 during warm-up operation but is sucked via the radiator 27 during the normal operation.

5 In this way, the water pump 80 is configured such that the cover cylindrical portion 95b or a cooling water sucking cylindrical nozzle of the water pump cover 95 is fitted into and fixed to the connection cylindrical portion 103. Therefore, the water pump 80 can be secured to the crankcase cover 100 without use of special members, screws, etc. This reduces the number of part  
10 components and provides satisfactory assemble workability.

A filter case 111 of the oil filter 110 is formed on the right-hand wall of the crankcase cover 100, a filter element is inserted into the filter case 111, which is covered by the filter cover 112 from the right, thus constituting the oil filter 110.

15

The filter case 111 is formed with an inflow passage 113a (see Fig. 13) with which the downstream outflow nozzle 62fl of the oil pump unit 60 and a connection pipe 124a communicate (see Fig. 4).

20 The front wall 101 of the crankcase cover 100 is formed with an oil passage 113b extending from the middle of the filter case 111 toward a bearing hole 101a adapted to journal the front end of the crankshaft 30 via a bearing 106. Oil passages 113c, 113d are formed to supply oil from the oil passage 113b to portions to be lubricated (see Fig. 13).

25

The internal combustion engine E is of an oil tank integral type. The crankcase cover 100 constitutes part of an oil tank 120. This part is formed of part of the front wall 101 at a position in front of the centrifugal type start clutch 56 so as to be surrounded by the circumferential wall 121.

30

The opening end face of the circumferential wall 121 is axially vertical and serves as a mating surface 121f with the oil tank cover 122. The inflow passage 123a and the outflow passage 123b are formed in the lower portion of the front wall 101 in the circumferential wall 121. The inflow passage 123a communicates with the

downstream side outflow nozzle 62rl of the oil pump unit 60 via a connection pipe (not shown). The outflow passage 123b communicates with the upstream side inflow nozzle 62fu of the oil pump unit 60 via a connection pipe 124b (see Fig. 4).

5

The oil tank cover 122 is formed of a circumferential wall 122a joined to the circumferential wall 121 of the oil tank 120 formed on the crankcase cover 100 and a front wall 122b covering the inside of the circumferential wall 122a so as to be flat bowl-like. The end face of the circumferential wall 122a serves as a mating surface 122r corresponding to the mating surface 121f on the side of the crankcase cover 100.

10

Thus, the oil tank 120 is constructed by abutting the mating surface 122r of the oil tank cover 122 against the mating surface 121f of the circumferential wall 121 of the crankcase cover 100, fastening them by means of bolts, and joining the circumferential wall 121 with the circumferential wall 122a.

15

As described above, the oil tank 120 can be disposed in the wide space that is located in front of, namely, on the axial outside of the centrifugal type start clutch 56. Therefore, the capacity of the oil tank 120 can be sufficiently ensured while reducing the axially outward expansion of the oil tank cover 122. In addition, in the internal combustion engine E equipped integrally with an oil tank, the entire internal combustion engine E can be downsized, thereby improving its mounting performance on the body frame 2.

20  
25

The cover cylindrical portion 95b protruding forward of the water pump 80 is fitted into and supported by the connection cylindrical portion 103 of the crankcase cover 100 constituting part of the oil tank 120. Therefore, as described above, the water pump 80 can be fastened to the crankcase cover 100 without use of special members, thereby providing satisfactory assembly workability.

30

The cover cylindrical portion 95b or sucking nozzle of the water pump 80 protrudes forwardly to form an opening end at its leading end. In addition, this opening end is located at substantially the same forward position as the front end

face of the centrifugal type start clutch 56 provided projectingly in the crankcase cover 100 so as to be spaced apart from the crankcase 31. Accordingly, when the crankcase cover 100 is removed in order to perform maintenance or the like, the crankcase 31 is unlikely to be splashed with water.

5 In addition, the cover cylindrical portion 95b or sucking nozzle of the water pump 80 protrudes to substantially the same forward position as the front end face of the centrifugal type start clutch 56 provided projectingly in the crankcase cover 100 and its front end has an opening. Therefore, the protruding space 102  
10 in the crankcase cover 100 can be effectively utilized without the provision of the special waterproof structure.

In the internal combustion engine E, the crankcase 31 is connected to the crankcase cover 100 through the spacer 70 and the water pump body 81 or part of the water pump 80 is formed integrally with the spacer 70. Accordingly, the  
15 crankcase cover 100 can be shared by water-cooled internal combustion engines only by replacing the simply configured spacer 70 without replacement of the crankcase cover having a various functions and being of large size. This makes it easy to change the cooling system and can reduce costs.

20 The spacer 70 is formed with the water pump body 81 of the water pump 80 and the water pump cover 95 is attached to the water pump body 81. Therefore, even for the relatively large-sized water pump 80, its water pump cover 95 is formed as a separate body on the spacer 70, whereby the spacer 70 can be downsized to facilitate its replacement.

25 Since the spacer 70 is formed integrally with the drain passage 83, it is not necessary to additionally arrange a pipe adapted to drain water leaking from the water pump 80 to the outside, thereby reducing the number of part components to improve assembly performance and improving the durability of drainage.

30 The water pump 70 is provided in the vicinity of the circumferential wall 71 of the spacer 70 and the drain passage 83 is formed to connect the water pump 80 with the outer surface of the circumferential wall 71 of the spacer 70. Therefore,

the drain passage 83 can be shortened and the cavity 72 inside the circumferential wall 71 of the spacer 70 can be utilized effectively.

- 5 Since the breather passage 85 of the water pump 80 is also formed integrally with the spacer 70, it is not necessary to additionally provide a vent pipe adapted to vent air from the water pump 80 to the outside. This further reduces the number of part components to improve assembly performance and improves the durability of the breather.
- 10 Since the breather passage 85 is formed to connect the water pump 80 with the outer surface of the circumferential wall 71 of the spacer 70, the breather passage 85 can be shortened and the cavity 72 inside the circumferential wall 71 of the spacer 70 can be utilized effectively.
- 15 Incidentally, while the internal combustion engine E is equipped with the centrifugal type start clutch 56 at the front end of the crankshaft 30, the present invention is applicable to the engine equipped with a torque converter or other power transmission control means that expands largely in the radial direction.
- 20 Although various preferred embodiments of the present invention have been described herein in detail, it will be appreciated by those skilled in the art, that variations may be made thereto without departing from the spirit of the invention or the scope of the appended claims.

**THE EMBODIMENTS OF THE INVENTION IN WHICH AN EXCLUSIVE PROPERTY OR PRIVILEGE IS CLAIMED ARE DEFINED AS FOLLOWS:**

1. A water-cooled internal combustion engine comprising: a  
5 crankshaft; power transmission control means disposed at an end of the crankshaft; and a water pump having a water pump drive shaft parallel to the crankshaft; wherein the water pump is disposed on the axial inside of the power transmission control means, that is, on the central side of the crankshaft.
- 10 2. The water-cooled internal combustion engine according to claim 1, wherein the water pump axially overlaps the power transmission control means.
3. The water-cooled internal combustion engine according to claim 1 or 2, wherein an oil tank is disposed on the axial outside of the power  
15 transmission control means.
4. The water-cooled internal combustion engine according to claim 3, wherein an outer end of the water pump is supported by an engine cover whose part constitutes the oil tank.  
20
5. The water-cooled internal combustion engine according to claim 4, wherein the outer end of the water pump serves as a cooling water-sucking nozzle which projects in the axial outside.

25

NAME OF DOCUMENT DRAWINGS

FIG. 1

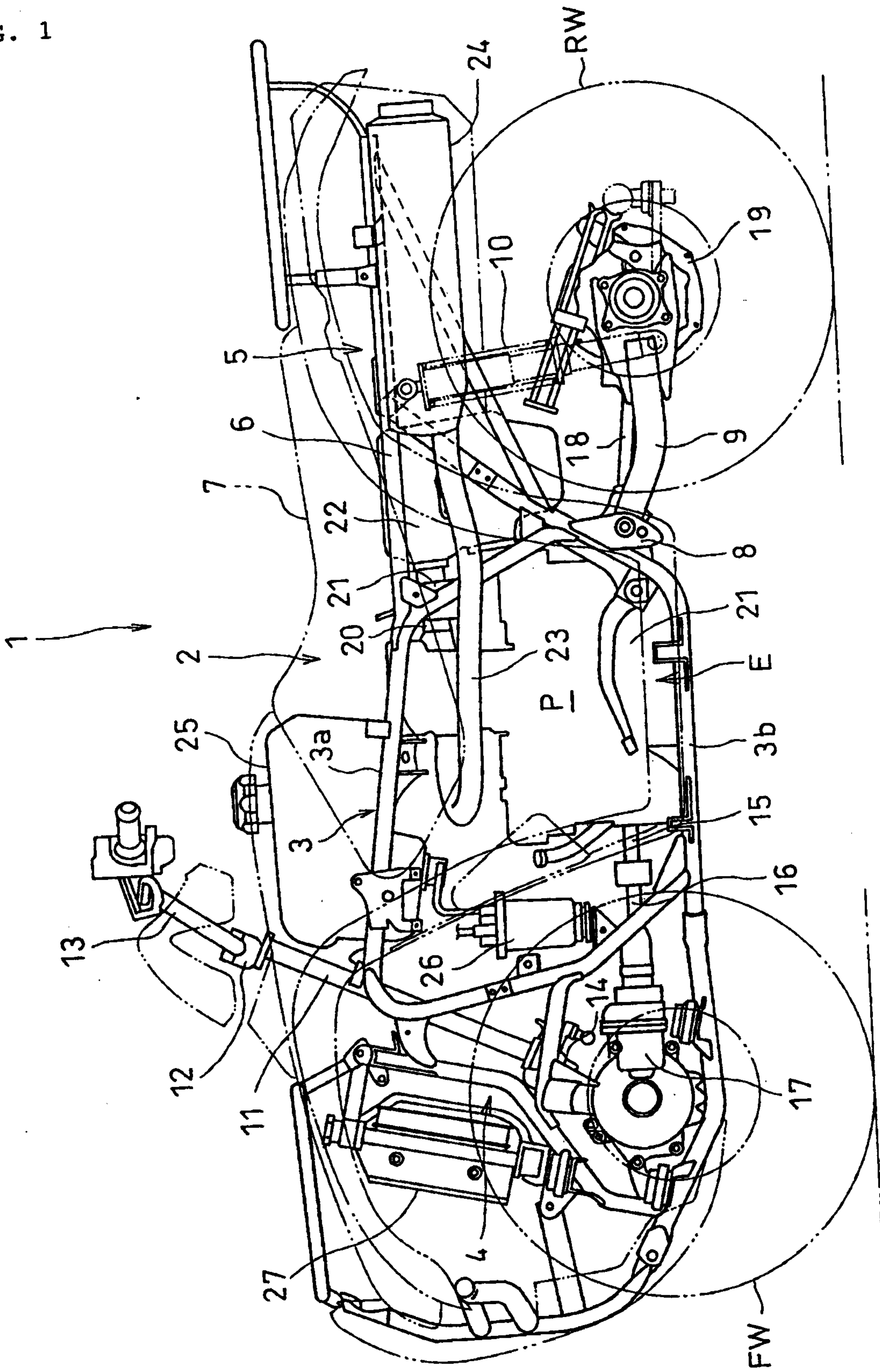

FIG. 2

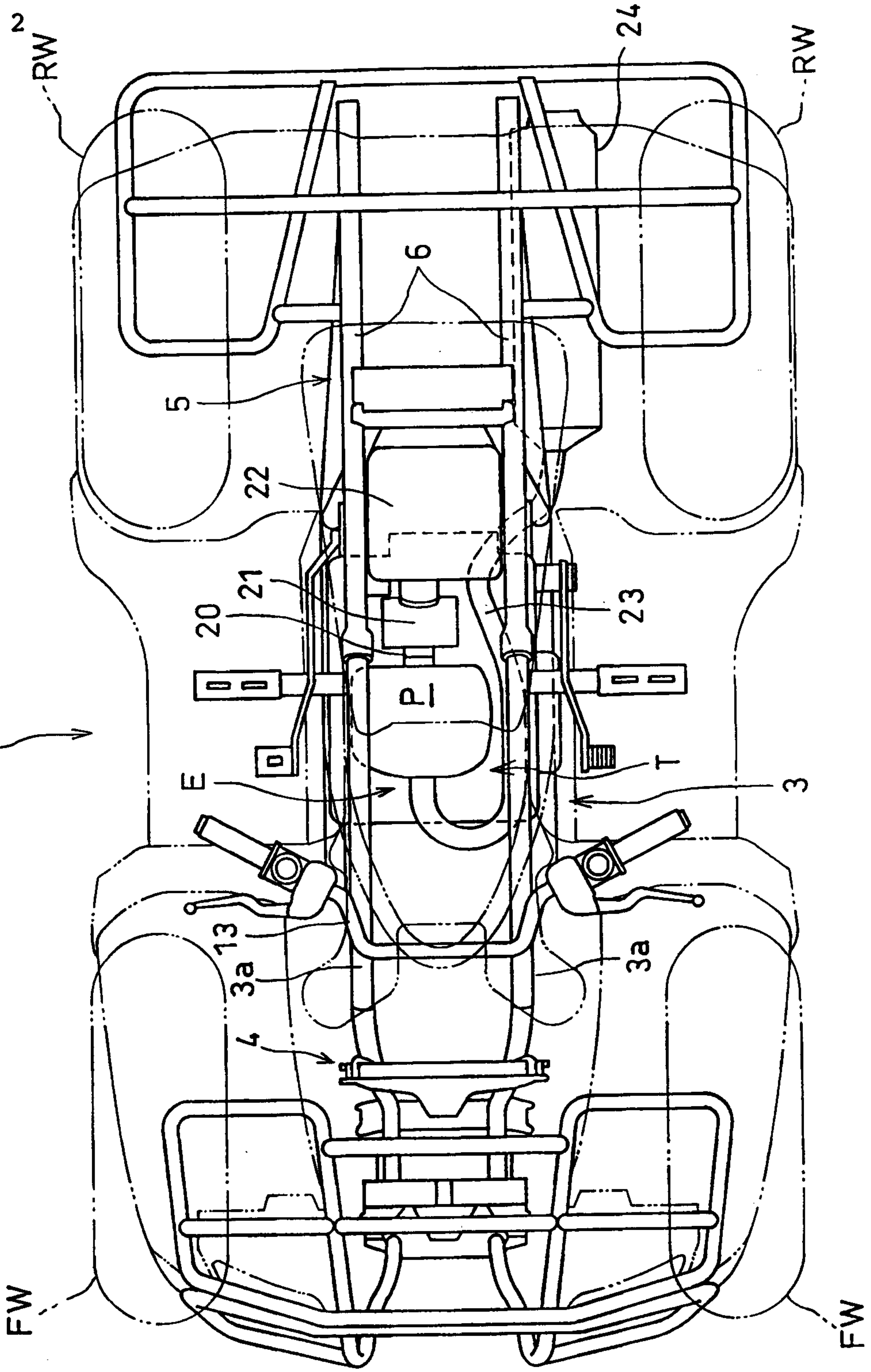

FIG. 3

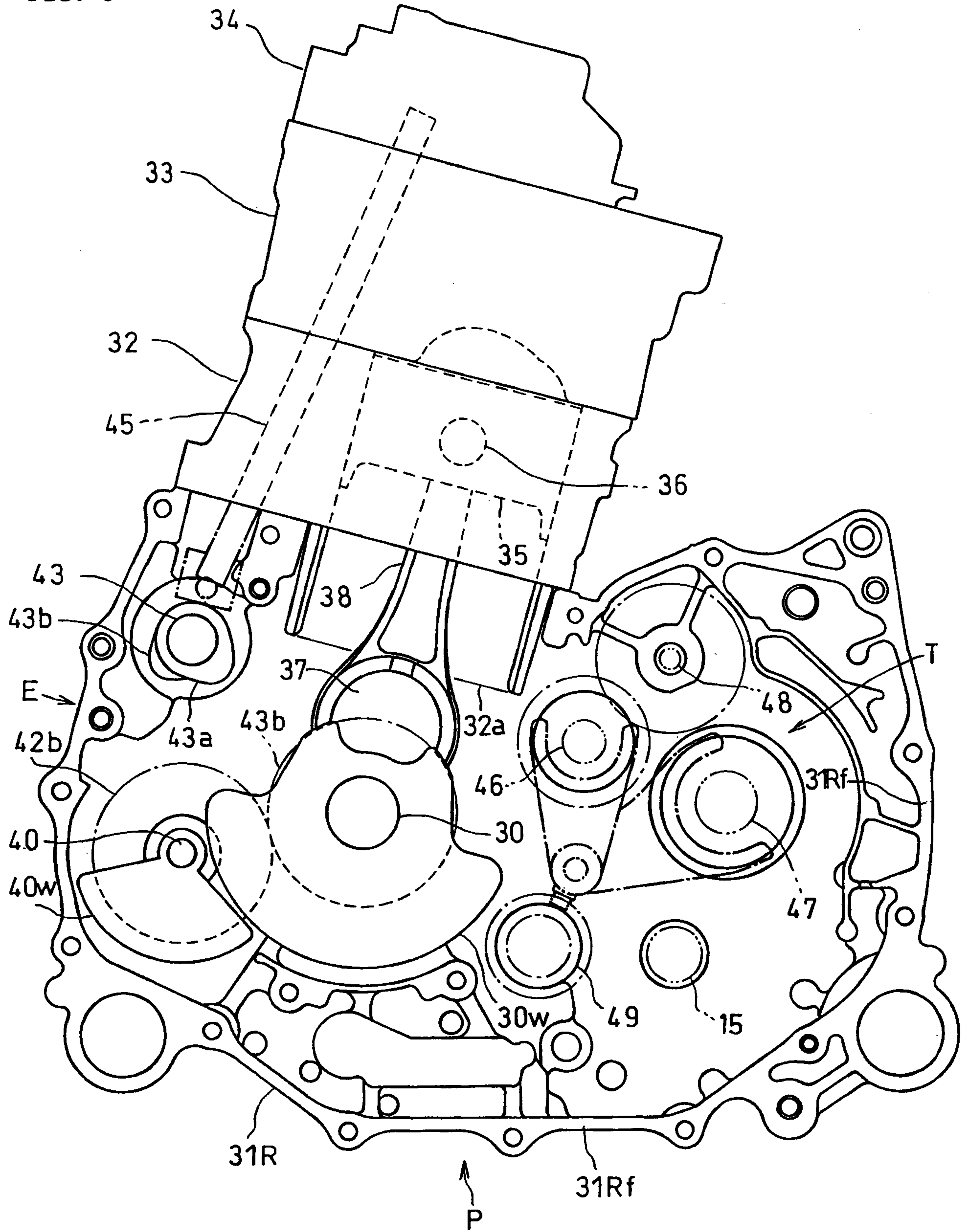

FIG. 4

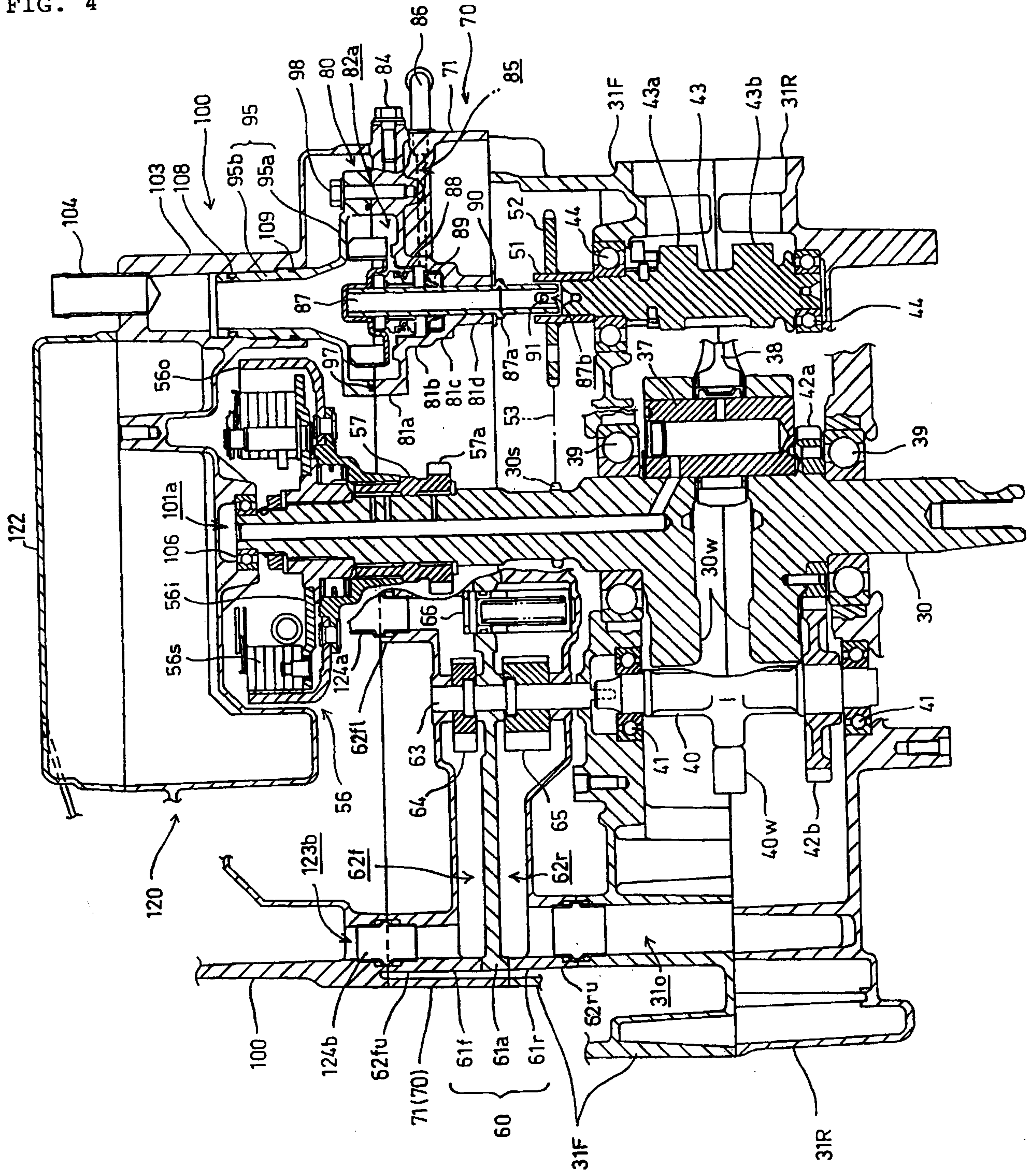

FIG. 5

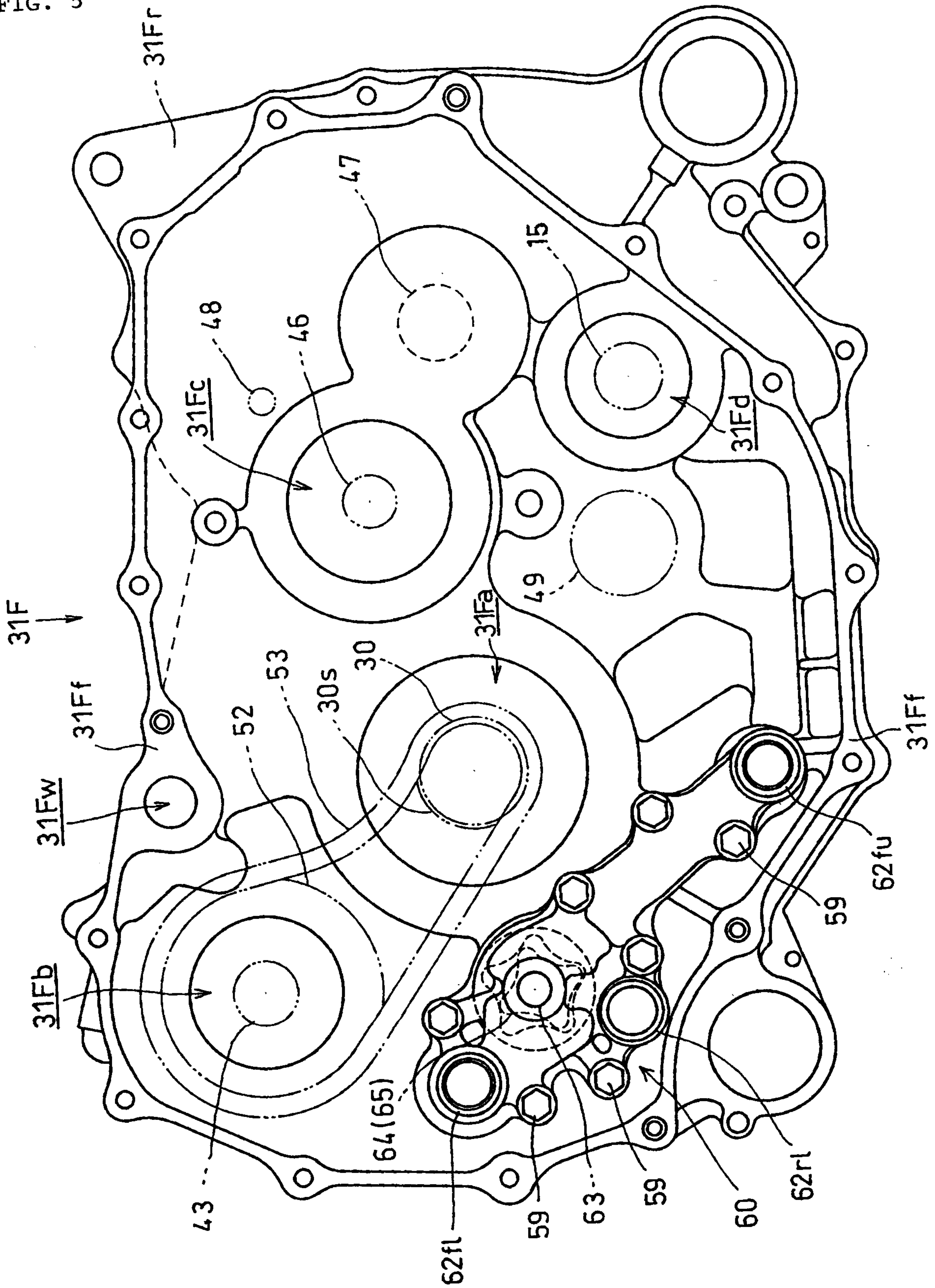

FIG. 6

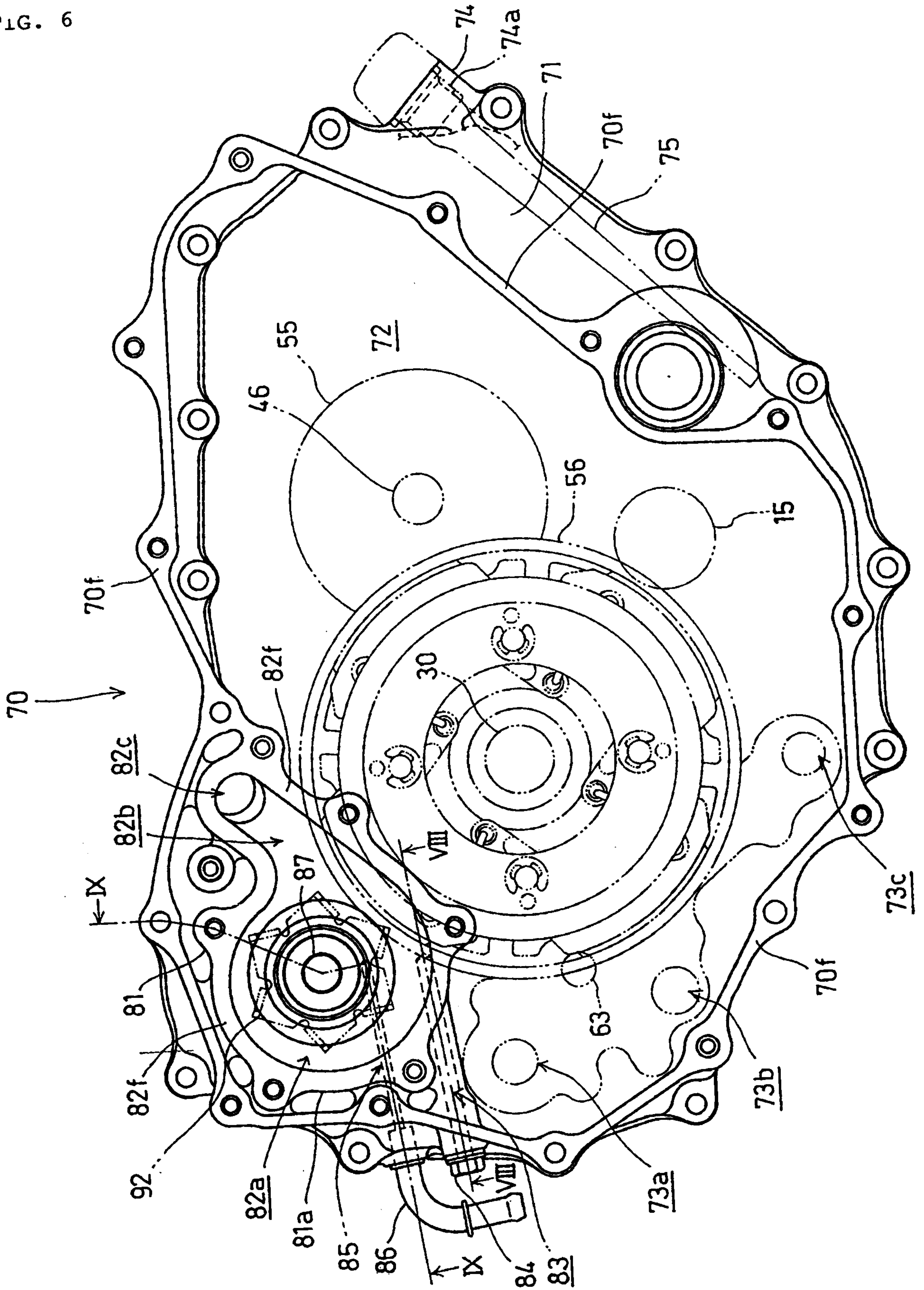

FIG. 7

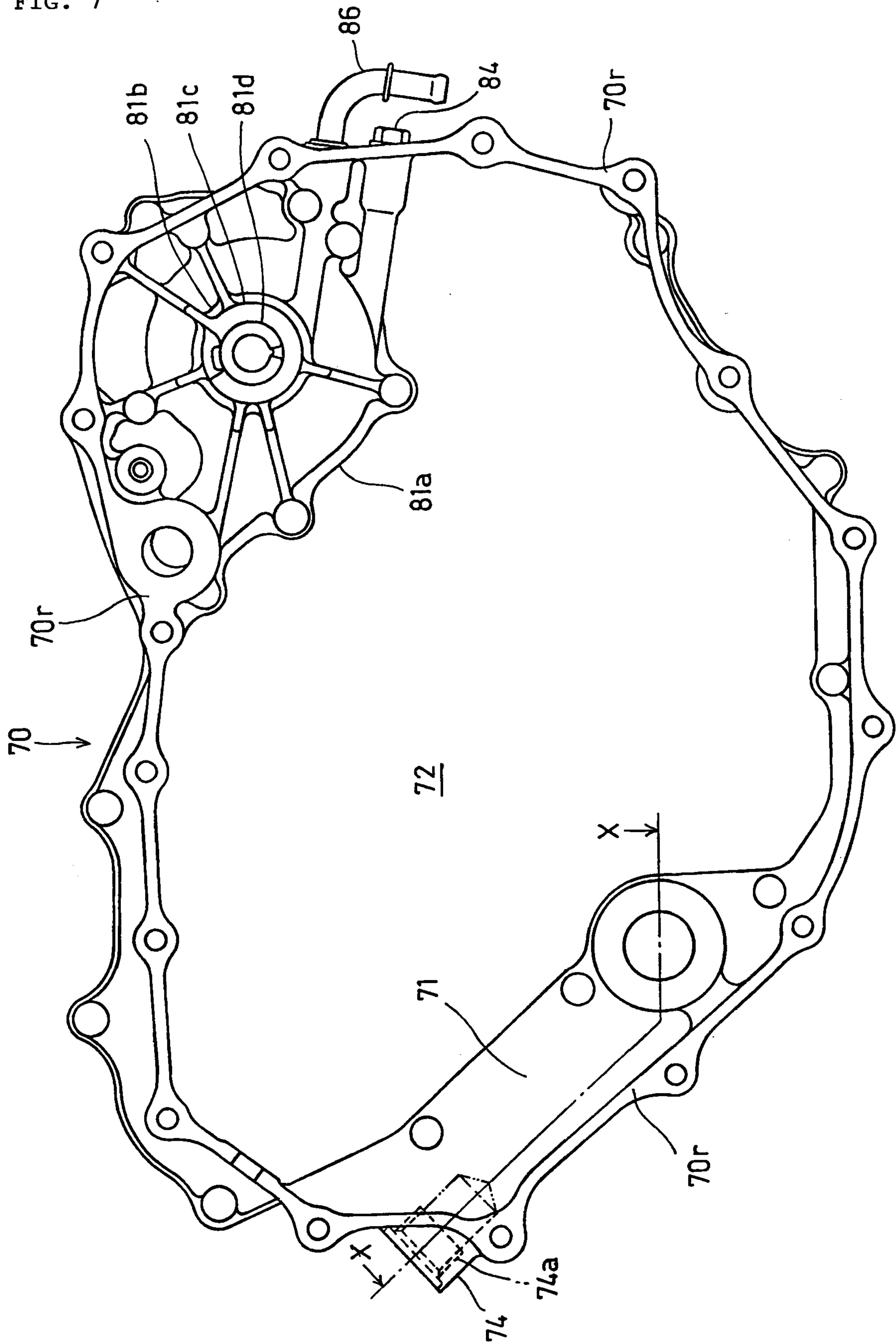

FIG. 8

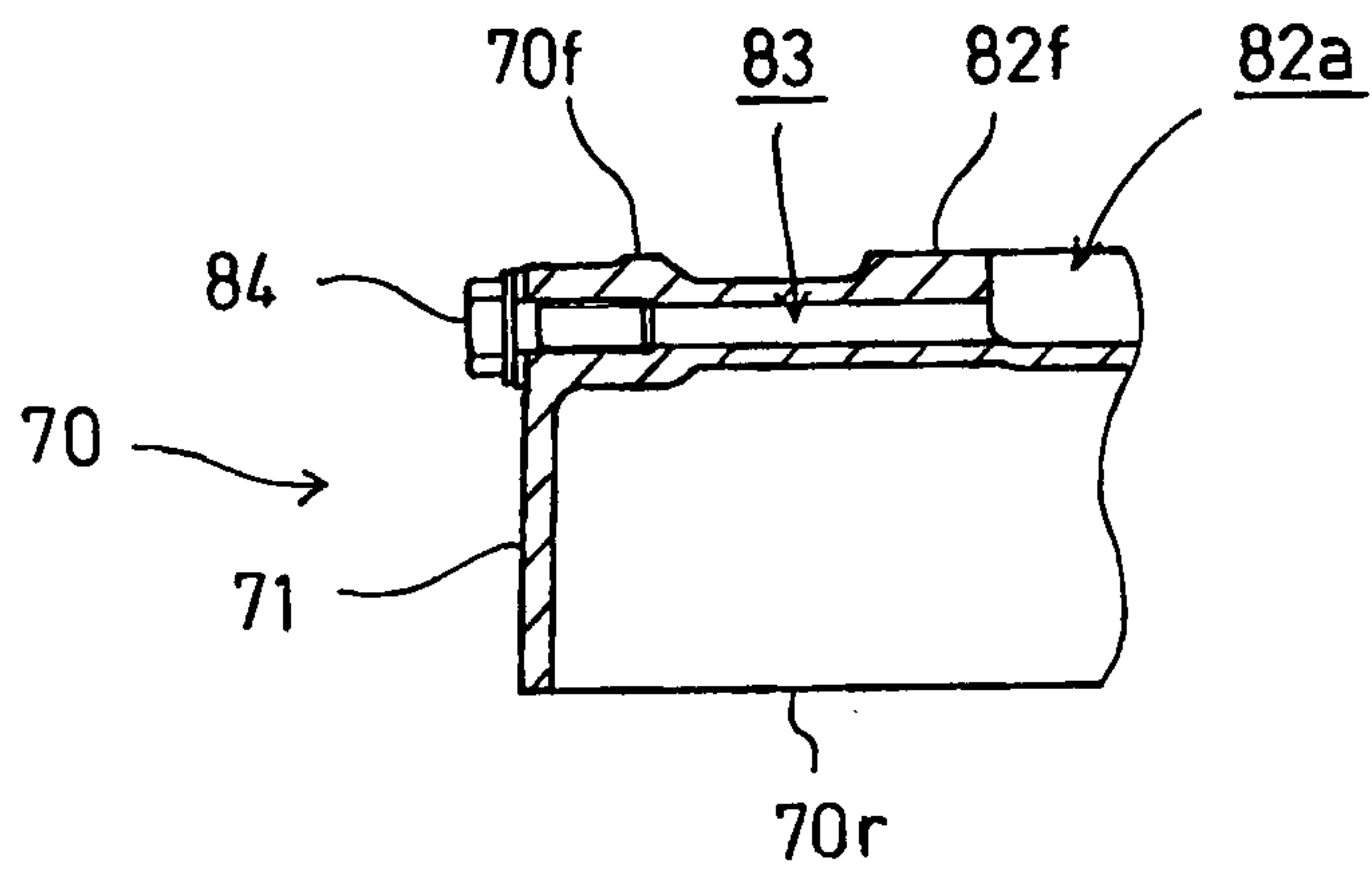

FIG. 9

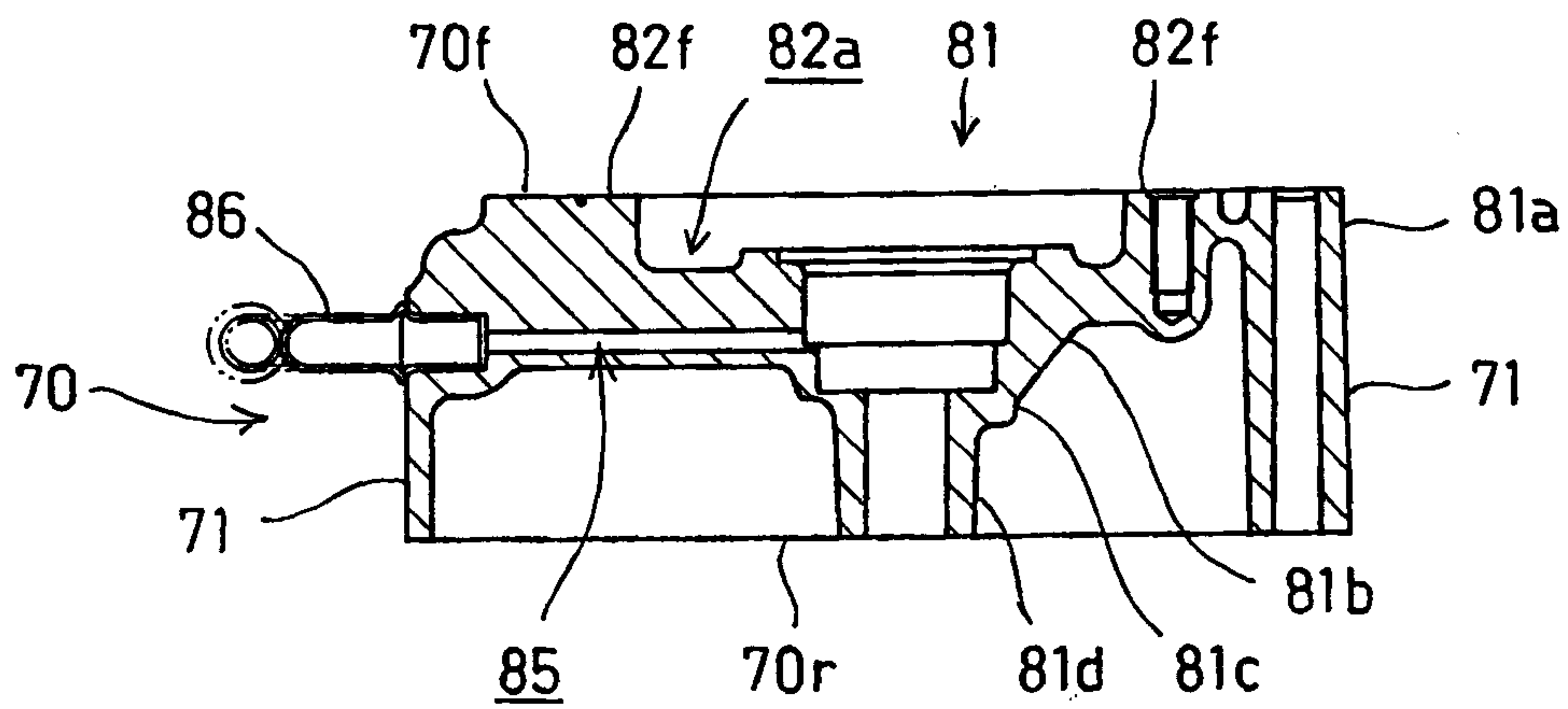

FIG. 10

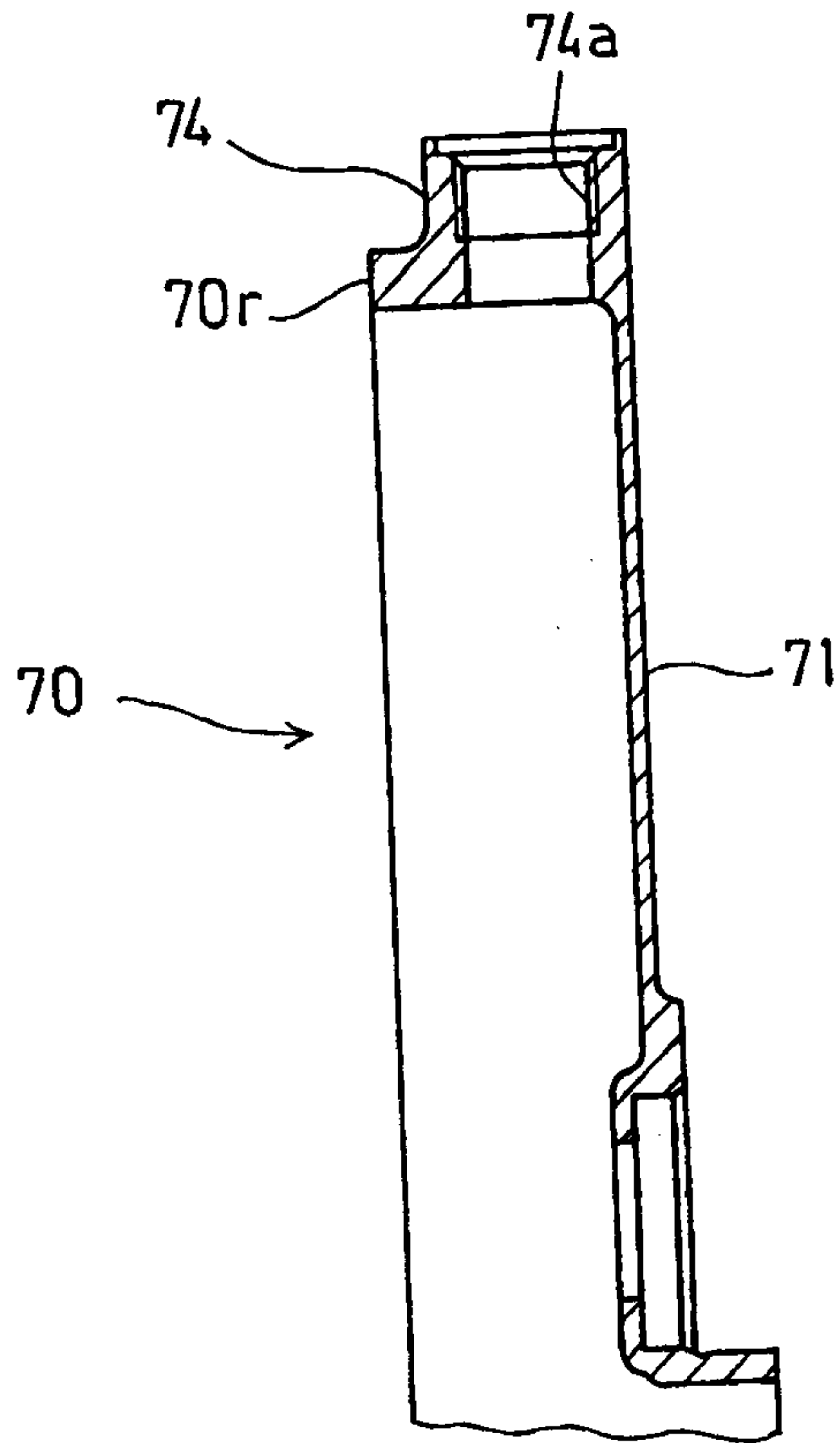
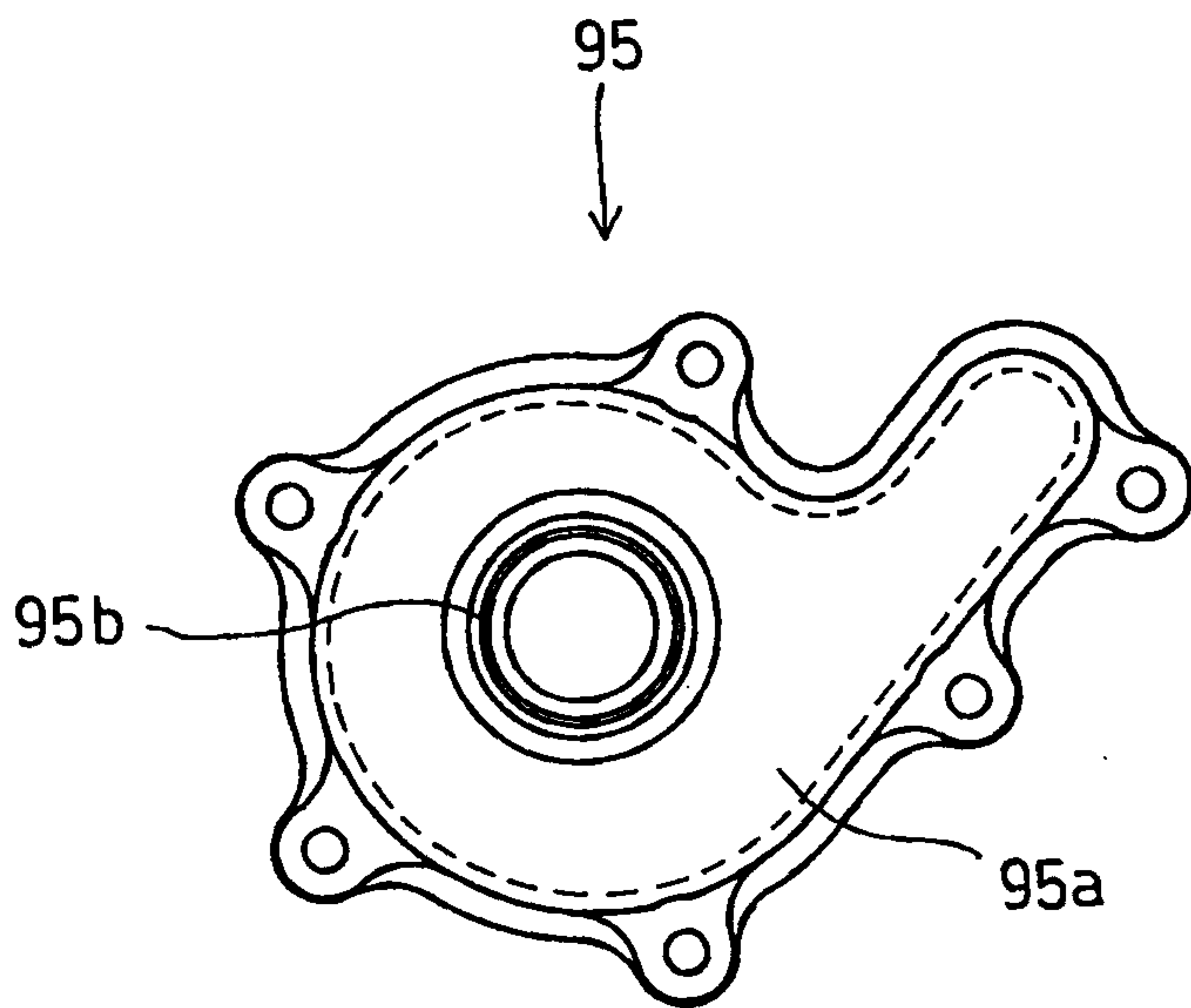

FIG. 11



串

FIG. 12

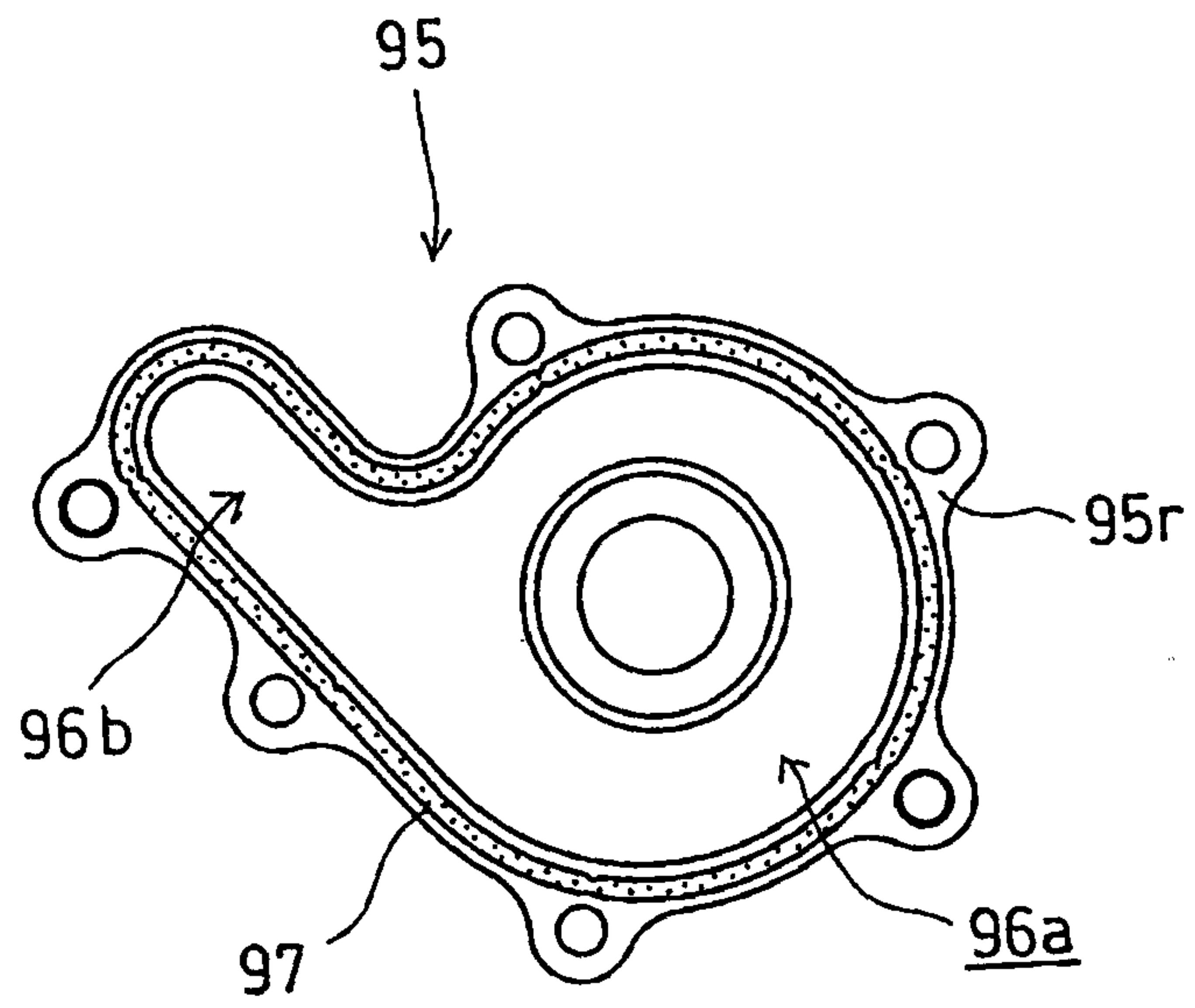

FIG. 13

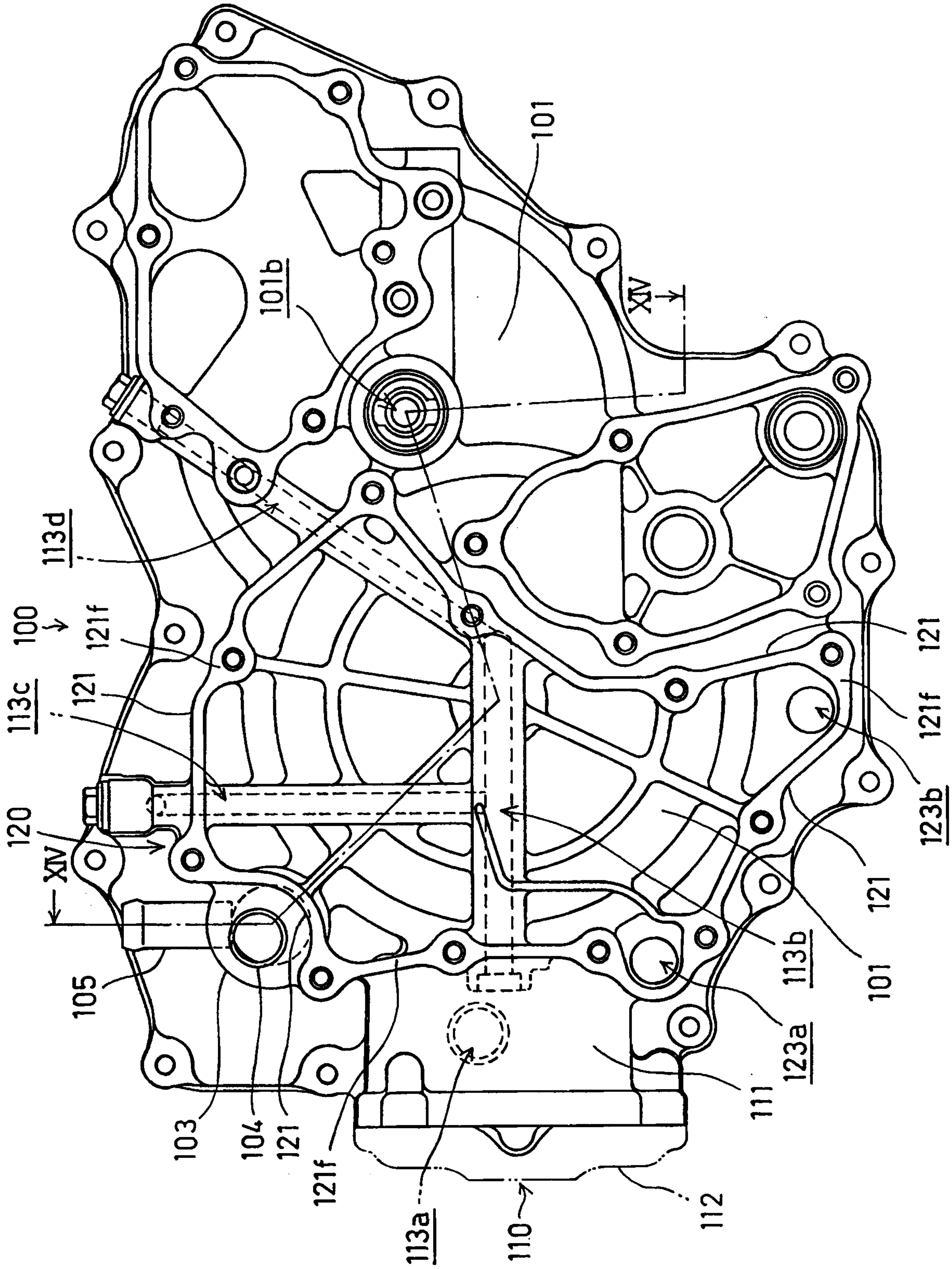

FIG. 14

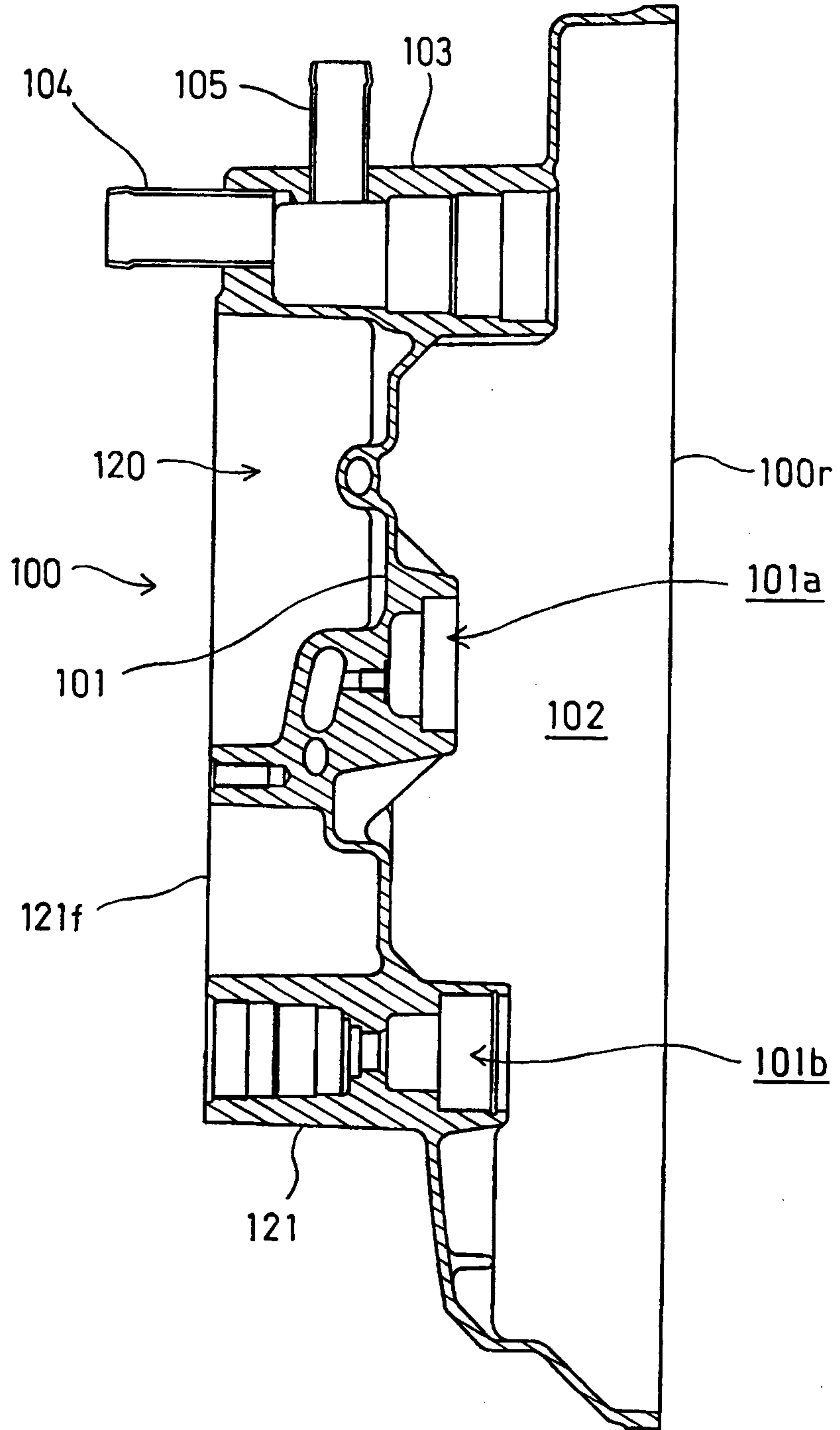

FIG. 15

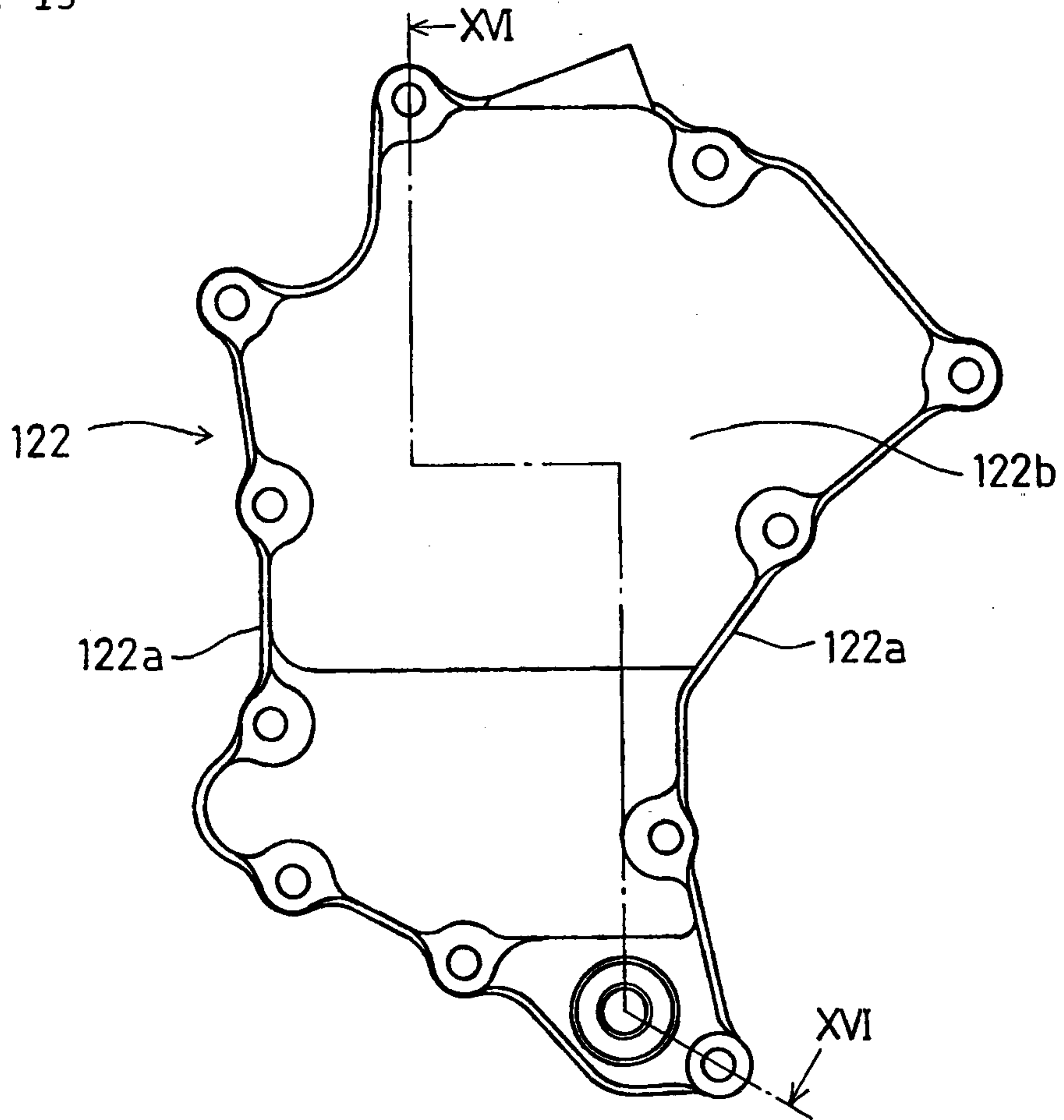

FIG. 16

