

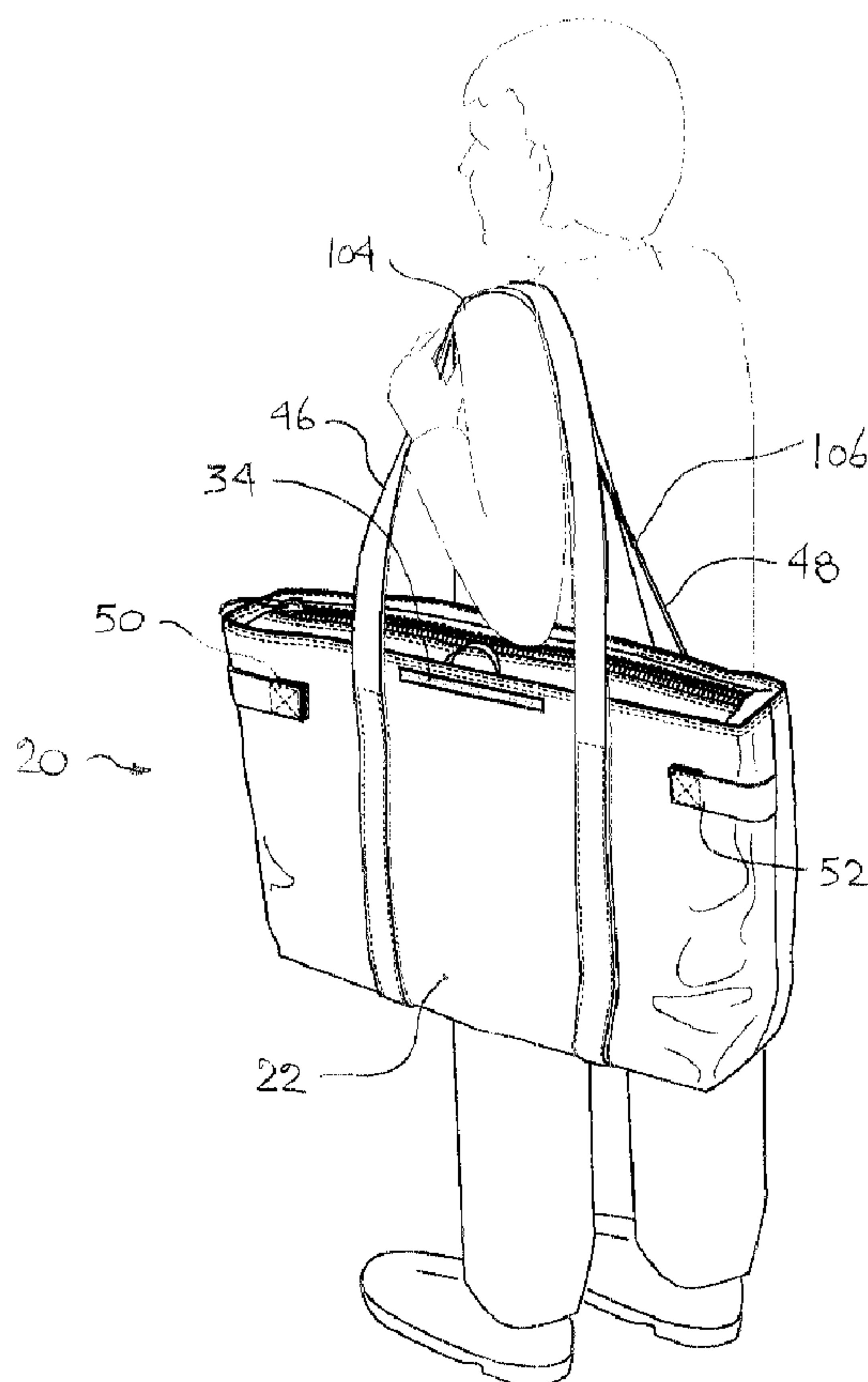

(22) Date de dépôt/Filing Date: 2003/01/10  
(41) Mise à la disp. pub./Open to Public Insp.: 2004/07/10  
(45) Date de délivrance/Issue Date: 2011/09/13

(51) Cl.Int./Int.Cl. *F25D 3/08* (2006.01),  
*A45C 11/20* (2006.01), *A45C 7/00* (2006.01),  
*B65D 81/38* (2006.01), *A45C 13/30* (2006.01),  
*A45C 3/04* (2006.01)  
(72) Inventeur/Inventor:  
MOGIL, MELVIN SHELDON, CA  
(73) Propriétaire/Owner:  
CALIFORNIA INNOVATIONS INC., CA  
(74) Agent: BERESKIN & PARR LLP/S.E.N.C.R.L.,S.R.L.

(54) Titre : SAC ISOTHERME PLIABLE  
(54) Title: FOLDABLE INSULATED BAG



(57) **Abrégé/Abstract:**

A soft sided insulated cooler bag has a base and side panels. The base includes a rigid or semi-rigid reinforcement or batten that serve to provide a relatively hard or stiff edge about which the bag can be panel folded over on itself. The upper edge of the bag has a length that is as great as half the periphery of the bottom panel. The bag can be collapsed to a flat position and then panel folded to a storage position. Retainers are provided to keep the bag in the storage position.

**FOLDABLE INSULATED BAG**Abstract of the Disclosure

5 A soft sided insulated cooler bag has a base and side panels. The base includes a rigid or semi-rigid reinforcement or batten that serve to provide a relatively hard or stiff edge about which the bag can be panel folded over on itself. The upper edge of the bag has a length that is as great as half the periphery of the bottom panel. The bag can be collapsed to a flat position and then panel folded to a storage position. Retainers are provided to keep the bag in the storage position.

10

## **FOLDABLE INSULATED BAG**

### Field of Invention

This invention relates to the field of foldable insulated containers.

5

### Background of the Invention

Collapsible insulated containers have been known for some years. They are typically used as containers for carrying cold drinks, and other cool refreshments, but can also be used to keep foods or beverages warm or hot.

10

Certain sizes and shapes of coolers are better for some purposes than others. Some collapsible coolers can be folded to a collapsed position, but the folding process may tend to require relatively strong hands, since the insulated panels may be of fair thickness, and may have a resilience that tends to resist folding. These containers tend to unfold easily, but tend to be rather more difficult to fold back into the collapsed or storage position. In the folded position, the front and rear walls remain in generally parallel planar orientation while the bottom panel is folded up in half, and the side panels are folded inward as shown in my issued US Patent Des. 382,771. This kind of cooler is secured in the folded position (a) by a hook-and-eye fabric strip securement between the overfolded lip of the lid portion of the cooler and the front face of the cooler and (b) by side fastening straps that retain the bottom portions of the front panel relative to the back panel, typically by wrapping at least partially around the back panel and being secured thereto with hook-and-eye strips. Coolers of this nature tend to be generally cubic in shape with rectangular sides forming, typically, a six sided box shaped structure when unfolded. A cooler of this type may also tend to require more manufacturing steps than a more bag-like cooler, and may therefore be more costly and time consuming to produce.

15

20

25

Rolling up a collapsible cooler, in the manner in which a sleeping bag is sometimes rolled up, may tend not to be particularly satisfactory in all circumstances. Users may tend to roll up the insulated material too tightly, either damaging the material, or tending to give it a permanent set. This tight rolling approach may also tend to favour persons with relatively strong hands.

30

5 It may be that a different kind of cooler is desired that may be somewhat more convenient for rapid use, that may be more quickly and easily folded, or that may provide greater ease of manufacture that may tend to pack efficiently for shipment, or that may present a relatively easily displayed product.

10 It may also be that it would be preferable to have a cooler that folds in a continuous direction, or that folds back and forth, on a folding panel basis rather than in a continuous tight roll like a sleeping bag.

15 In the view of the present inventor, there is a need for a foldable insulated container, or bag, that is more easily constructed than the more box shaped type of cubic collapsible insulated container, that may tend to require fewer, or simpler, manufacturing steps, or that may tend to provide an easily displayed and relatively convenient insulated container for everyday use.

#### Summary of the Invention

20 In an aspect of the invention, there is a soft sided insulated cooler container in which one portion page-folds against another along pre-defined panel folds on a discrete number of fold lines.

25 In an aspect of the invention, there is a foldable insulated bag comprising an insulated wall structure, defining an insulated space therewithin. The wall structure has a closure member operable to govern access to the insulated space. The wall structure includes a forming panel. The wall structure, when empty, is movable to a first, flattened position. The wall structure is foldable over on itself about at least a portion of the forming panel to a folded storage position. The wall structure is securable in the folded storage position.

30 In an additional feature of that aspect of the invention, the bag is a double fold bag. In another additional feature, the bag includes a retainer. The retainer is operable to secure the bag in the folded storage position. In yet another additional feature, the bag has a bottom region and a top region, and the suspension member is mounted distant from the bottom region.

In still another additional feature, the forming panel includes a stiffener member. In yet still another additional feature, the forming panel has a flexural rigidity greater than any other portion of the bag. In yet another additional feature, the forming panel has an insulating layer and a stiffening layer. In a further additional feature, the forming panel includes a stiffened straight edge. In still a further additional feature, the forming panel includes a pair of spaced apart, parallel stiffened straight edges. In yet a further additional feature, the bag has a base panel and a sidewall structure mounted about the base panel. The forming panel is the base panel.

In still yet a further additional feature, the sidewall structure includes first and second opposed sidewall panels. Each side wall panel has a first edge adjoining the base panel and a second edge distant therefrom. The closure member is mounted to the distant edges.

In another additional feature, the sidewall structure includes first and second opposed sidewall panels. Each side wall panel has a first edge adjoining the base panel and a second edge distant therefrom. The side wall panels have an altitude measured between the first and second edges, and the base panel has a width measured between junctures of the adjoining edges of the sidewall panels therewith. The altitude has a magnitude  $X$ , and the width has a magnitude  $Y$  wherein  $X$  has a value lying on one of the ranges chosen from the set of ranges consisting of (a)  $0.8 Y$  to  $1.2 Y$ ; (b)  $1.8 Y$  to  $2.2 Y$ ; and (c)  $2.8 Y$  to  $3.2 Y$ .

In still another additional feature, the foldable insulated bag has a retainer operable to secure the foldable insulated bag in the folded storage position. The sidewall structure includes first and second opposed sidewall panels. Each sidewall panel has a first edge adjoining the base panel and a second edge distant therefrom. The base panel has a first edge connected to the first sidewall panel, and a second edge connected to the second sidewall panel. The base panel has an outer face, and an inward face. In the flattened position the inward face of the base panel is oriented to face toward the second sidewall panel. In the flattened position the first edge of the base panel lies nearer than the first edge of the base panel to the second edge of the first sidewall panel. The outward face of the base panel has a first member of the retainer mounted thereto adjacent to the second edge thereof. The first sidewall panel has a second member of the retainer mounted adjacent to the second edge thereof. The base panel is movable to bring the first portion of the retainer into mating

engagement with the second portion of the retainer. In yet another additional feature, the first and second portions of the retainer are mating hook-and-eye fabric strip portions.

5 In still yet another additional feature, the sidewall structure includes first and second opposed sidewall panels. Each sidewall panel has a first edge adjoining the base panel and a second edge distant therefrom. The base panel has a periphery. The periphery includes a first edge adjoining the first edge of the first sidewall panel, and a second edge adjoining the first edge of the second sidewall panel. The periphery includes two opposed remainder portions between the first and second sides. The portions have lengths  $2a_1$  and  $2a_2$  respectively. The first edge of the first sidewall panel has a length,  $L$ . The first edge of the base panel has a length 'b'. The length  $L$  is at least as great as  $b + (a_1 + a_2)$ .  
10

In a further additional feature, the first edge of the first sidewall panel is centered relative to the first edge of the base panel. In yet a further additional feature, the sidewall structure includes first and second opposed sidewall panels. Each sidewall panel has a first edge adjoining the base panel and a second edge distant therefrom. The base panel is rectangular, having two opposed sides of length 'b' and two opposed sides of length 'a'. The first edge of the first sidewall panel has a length,  $L$ . The length  $L$  is at least as great as  $b + 2a$ . In still a further additional feature, the first edge of the first sidewall panel is centered relative to the first edge of the base panel.  
15  
20

In still yet a further additional feature, the sidewall structure includes equal sized first and second opposed sidewall panels. Each side wall panel has a first edge adjoining the base panel and a second edge distant therefrom. In another additional feature, the first edges of the first and second sidewall panels have a length  $L_1$ , and the second edges of the sidewall panels have a length  $L_2$ , where  $L_2$  is at least as great as  $L_1$ . In still another additional feature, each of the sidewall panels has a second edge distant from the first edge thereof. The second edges of the sidewall panels are each longer than the base panel.  
25

In yet another additional feature, the sidewall structure includes a pair of opposed first and second sidewall panels. The first and second sidewall panels each includes a first edge mounted to the base panel, a second edge opposed to and distant from the second edge, a third edge, and a fourth edge. The fourth edge is opposed to the third edge. The respective third edges are mutually attached. The respective fourth edges are mutually attached. In another additional feature, the insulated bag includes a waterproof liner. In a further  
30

additional feature, the insulated bag includes reflective interior surface oriented to face toward objects placed in the insulated space.

5 In another aspect of the invention, there is a foldable insulated bag comprising a first side panel, a second side panel, and a base panel. At least the first side panel and the second side panel is insulated. At least the first side panel and the second side panel is pliable. The first side panel, the second side panel and the base panel co-operate to define an enclosed, insulated space. The first side panel has a first base edge adjoining the base panel. The second side panel has a second base edge adjoining the base panel. The first side panel has a first distal edge opposite to the first base edge. The second side panel has a second distal edge opposite to the second base edge. At least a portion of the first distal edge is movable relative to at least a portion of the second distal edge to permit access to the enclosed insulated space. A closure member is mounted to govern access to the enclosed, insulated space. The base panel has a length and a width, the length being greater than the width. The distal edge of the first side panel is longer than the base panel.

15 These and other aspects of the invention may be more readily understood with the aid of the illustrative Figures and detailed description included hereinbelow.

20 Brief Description of the Drawings

In the illustrative Figures of an example, or examples, embodying the various aspects of the invention, provided by way of illustration, but not of limitation of the present invention:

- 25
- Figure 1 shows a perspective view of an example of a foldable insulated bag of an embodiment of the present invention as carried by a user;
  - Figure 2 shows a perspective view of the bag of Figure 1 as installed in the trunk of an automobile;
  - 30 Figure 3a shows a perspective view of the bag of Figure 1 as folded;
  - Figure 3b shows a front view of the bag of Figure 3a in a fully folded condition;
  - Figure 3c shows a rear view of the bag of Figure 3a in the fully folded condition;
  - Figure 3d shows a left hand end view of the bag of Figure 3a in the fully folded condition;

Figure **3e** shows a right hand end view of the bag of Figure **3a** in the fully folded condition;

Figure **3f** shows a top view of the bag of Figure **3a** in the fully folded condition;

Figure **3g** shows a bottom view of the bag of Figure **3a** in the fully folded condition;

5 Figure **3h** shows the bag of Figure **3c** with an alternate hang loop orientation;

Figure **4a** shows a perspective view of the unfolded bag of Figure **1**.

Figure **4b** shows a front view of the bag of Figure **4a** in a fully unfolded condition;

Figure **4c** shows a rear view of the bag of Figure **4a** in the fully unfolded condition;

10 Figure **4d** shows a left hand end view of the bag of Figure **4a** in the fully unfolded condition;

Figure **4e** shows a right hand end view of the bag of Figure **4a** in the fully unfolded condition;

Figure **4f** shows a top view of the bag of Figure **4a** in the fully unfolded condition;

15 Figure **4g** shows a bottom view of the bag of Figure **4a** in the fully unfolded condition;

Figure **5** shows a cross sectional view of the bag of Figure **1**, taken abeam of the handles (with the handles not shown);

Figure **6a** shows a front view of the bag of Figure **1** in a partially folded condition;

Figure **6b** shows a rear view of the bag of Figure **6a**;

20 Figure **6c** shows a left hand end view of the bag of Figure **6a**;

Figure **6d** shows a right handed view of the bag of Figure **6a**;

Figure **7a** shows a perspective view of the bag of Figure **1** in an open condition with a liner thereof in an inverted position to facilitate washing thereof;

Figure **7b** shows a perspective view of the bag of Figure **1** in an open condition;

25 Figure **8** shows a developed view of panels of the bag of Figure **1** prior to assembly;

Figure **9a** shows a developed view of a bottom panel for an alternate embodiment of the foldable insulated bag of Figure **1**;

Figure **9b** shows a developed view of a side panel for an alternate embodiment of the foldable insulated bag of Figure **1**;

30 Figure **10a** shows an isometric view of a single fold, alternate insulated bag to that of Figure **1**;

Figure **10b** shows a front view of the insulated bag of Figure **10a** in a folded condition;

Figure **10c** shows a rear view of the insulated bag of Figure **10a** in a folded condition;

Figure **10d** shows a left hand end view of the insulated bag of Figure **10a**;

Figure **10e** shows a right hand end view of the insulated bag of Figure **10a**;

5 Figure **10f** shows a top view of the insulated bag of Figure **10a**;

Figure **10g** shows a bottom view of the insulated bag of Figure **10a**;

Figure **11a** shows a partially unfolded front view of a triple fold, alternate insulated bag to that of Figure **1**;

10 Figure **11b** shows a front view of the insulated bag of Figure **11a** in a folded condition;

Figure **11c** shows a rear view of the insulated bag of Figure **11a** in a folded condition;

Figure **11d** shows a left hand end view of the insulated bag of Figure **11a**;

Figure **11e** shows a right hand end view of the insulated bag of Figure **11a**;

15 Figure **11f** shows a top view of the insulated bag of Figure **11a**;

Figure **11g** shows a bottom view of the insulated bag of Figure **11a**.

20

#### Detailed Description of an Embodiment of the Present Invention

The description that follows, and the embodiments described therein, are provided by way of illustration of an example, or examples, of particular embodiments of the principles  
25 of the present invention. These examples are provided for the purposes of explanation, and not of limitation, of those principles and of the invention. In the description, like parts are marked throughout the specification and the drawings with the same respective reference numerals. The drawings are not necessarily to scale and in some instances proportions may have been exaggerated in order more clearly to depict certain features of the invention.

30

For the purposes of this description, the largest panels of the bags herein described are arbitrarily designated as the front and rear sides, faces, or portions of the bag. Similarly, the closure member, or opening of the bag is arbitrarily designated as being at the top, and the base panel is designated as being at the bottom. It should also be understood that, within

the normal range of temperatures to which human food and human touch is accustomed, although the term cooler, or cooler container, or cooler bag, may be used, such insulated structures may generally also be used to keep food, beverages, or other objects either warm or hot as well as cool, cold, or frozen.

5

As seen in the Figures, an example of a portable, collapsible soft sided, insulated wall structure is identified as a foldable cooler tote bag **20**. This structure can be referred to as an insulated bag, an insulated container, a cooler, or such like. The basic structure of bag **20** includes a first side panel, or wall, or sidewall, arbitrarily designated front panel **22**, a second side panel, or wall, or sidewall, designated arbitrarily as rear panel **24**, and a third panel or wall identified as a bottom, or base panel **26**. As described more fully below, these panels are joined together to form a pouch, or bag, having an enclosed internal space **25** surrounded by insulated walls. The enclosed volume of internal space **25** varies with the condition of the bag. That is, while the bag is in a folded (that is, collapsed) condition or position, or is lying flat, the internal volume is negligibly small, if not zero. However, when bag **20** is in an unfolded condition, or expanded position, it may tend to take on a shape to accommodate objects placed within the internal space, and it may assume a suitably capacious internal volume.

When bag **20** is in use, access to the internal volume, namely internal space **25** thereof, is governed by a closure member **28**. In the illustrated example, closure member **28** may be a linear tracked closure device in the nature of a zipper assembly **30** mounted between the upper margins of the side wall panels, namely front and rear panels **22** and **24**. Other kinds of closures could be used such as a velcro (t.m.) hook-and-eye fabric closure, a series of spaced apart snaps, a continuous mating plastic tongue and groove or other device. A relatively robust zipper assembly is preferred, as it may tend to provide a simple, quick, and relatively strong closure.

While bag **20** can be made water-tight by other means, it is preferred to provide a liner **32** that can be either sewn in place, or may be removable, or it may be wholly or partially invertible. A liner that is at least partially invertible, or removable, is preferred, since this may facilitate washing.

30

When the bag is not in use, it may tend to be readily foldable. First, the bag is collapsed by lying it flat and folding front sidewall panel **22** near its bottom margin such that base panel **26** lays in a more or less flat orientation relative to the rear sidewall panel, **24**, as seen in Figures **6a** and **6b**. In this, collapsed, generally flattened, position, the upward edge **36** of base panel **26** (namely the edge that is folded toward front sidewall panel **22** and hence toward what would normally be the upper parts of bag **20** generally) acts as a former, or form, for bending the body of bag **20** to define a first fold by rotating the folded part of the bag in the direction of arrow 'A' (counter-clockwise in the Figures, but arbitrary since it would be clockwise if viewed from the other direction, and bag **20** can be made with either a left handed or right handed fold). This permits one portion of bag **20** to fold over on another portion, in the manner of folding a page over on itself.

When page-folded in the direction of arrow 'A', bag **20** will arrive at the folded position shown in Figures **3a** – **3g**, in which position it is held by a securement member, or retainer, identified as **34**, which may take the form of a pair of mating securement strips such as hook-and-eye velcro (t.m.) strips **38** and **40** mounted, respectively, to the upper body portion of front side panel **22** adjacent the upper margin thereof, and to the distal margin region of base panel **26** that is distant from the forming edge of base panel **26**, such that when base panel **26** is overfolded in the direction of arrow 'A' strips **38** and **40** are brought into mating contact in a single relatively uncomplicated, and possibly quite swift motion. The result is a soft sided insulated container that has been collapsed, and then panel-folded over on itself (i.e., not scrunched into a tight roll) to a flat folded position, or flat folded condition, such as may be suitable, for example, for stacking, transport, display or storage. Display and storage is facilitated by a suspension member **42**, in the nature of a hang loop **44**, mounted generally centrally along the upper margin of front panel **22**. To the extent that loop **44** is mounted higher than the center of gravity of bag **20** more generally, bag **20** will tend to hang with the upper margin of front panel **22** in a generally horizontal orientation. An alternate hang loop location is shown in Figure **3h**, in which hang loop **44** is located at an end edge such that, when displayed for sale, bag **20** may tend to hang in a vertical, or substantially vertical orientation, namely with the long dimension (as folded) running up and down, i.e., more or less vertically.

Unfolding may tend to be a similarly uncomplicated and convenient procedure: the retainers are released, the bag is unfolded and it is ready to accommodate objects that need to

stay cool or warm. When unfolded, lifting members in the nature of handles, or straps **46, 48** that extend from the upper regions of the sidewall panels, namely panels **22** and **24**, can be grasped to lift bag **20**, and may, as illustrated in Figure **1**, be found suitable for carrying over a person's shoulder. Alternatively, or additionally, as illustrated in Figure **2**, bag **20** is provided with auxiliary securement devices **50, 52**, such as may be in the nature of velcro straps, to engage the felt-like or fibrous mat interior of an automobile, especially an automobile trunk, or boot, or cargo carrying area of a station wagon, van, or sports or utility vehicle. Securement devices **50, 52** may tend to be used to discourage a loaded bag **20** from tipping over when travelling, such as when bringing cold items home from the grocery store, or such as when transporting refreshments to a campsite, picnic site, playing field, or arena.

Considering the construction of bag **20** in greater detail, reference is made to the developed views of panels **22, 24** and **26** provided in Figure **8**. In the developed views shown in the example of Figure **8**, the side panels, namely insulated front and rear panels **22** and **24**, are of the same size and shape, and are generally rectangular. They have a breadth dimension indicated as 'X' measured along either the upper or lower marginal edges **54, 56**, and a height dimension indicated as 'Y', measured perpendicular to dimension 'X', along the side edges **58, 60**. By inspection,  $L_1 = 'X' = b_1 + 2a_1$ .

Insulated base panel **26** is also generally rectangular, having a long dimension measured along long edges **62, 64**, and indicated generally as 'b', and a short dimension measured along the short, end edges **66, 68**, indicated generally as 'w'. In this embodiment, the half width of the panel is identified as 'a<sub>1</sub>', and is equal to half of 'w'. The ratio of the half width 'a' to the length 'b' may tend to be in the range of less than about 1 : 2 and greater than about 1 : 16, or within the narrower range of less than about 2 : 5 and greater than about 1 : 8, or within the preferable range of less than about 1 : 3 and greater than about 1 : 6. In one particular example the ratio may be about 3 ¼ : 11 ½, in another particular example the ratio may be about 3 ¼ : 15 ½, and in a third particular example the ratio may be about 3 ¾ : 17 ½.

The width of base panel **26** may also be related to the overall height of bag **20** when unfolded. That is, it is preferred that retainer strip **40** on the off-side of base panel **26** mate with retainer element **38** on front panel **22** of bag **20** at a region close to the upper edge **70** of bag **20** generally, to yield a neatly folded bag for efficient packing, shipping and display. To

that end, with allowance for a bend radius, it is preferred that the height of bag **20** be within +/- 20 %, and more preferably within +/- 10 %, of an integer multiple of the width of base panel **26**. It is also preferred that bag **20** be a double or triple folded bag. While bags with a greater number of folds are possible, the benefits of ease of manufacture, ease of folding, and ease of use may not necessarily tend to be as marked for a larger number of folds.

The upper edge, i.e., upper marginal edge **54**, of each of the side panels **22** and **24** is longer than the long dimension 'b' of the bottom, or base panel **26**, such that when the closure member is secured, bag **20** may tend to have an upwardly broadening profile when viewed from the side, and an upwardly narrowing profile when viewed from the end. In the embodiment of Figure **8**, the periphery of base panel **26** is equal to  $2(2a_1 + b)$ . Each of the side wall panels, namely front and rear panels **22** and **24**, has a lower, or bottom edge, **56** noted above. Each of these bottom edges **56** extends about one half of the periphery of base panel **26**, having a central portion of length 'b' and two opposite end portions, each of length 'a<sub>1</sub>', or thereabout. In this instance, when bag **20** is collapsed, and bottom panel **26** is laid flat, a triangular end fold will be created, made up of the triangular folds **72** of the bottom corners of the side wall panels, those triangular portions being indicated as triangular regions **74** on Figure **8**, and being bounded by fold lines **76**, **78**.

When assembled, front and rear panels **22**, **24** are sewn together along their upwardly extending edges **58**, **60**, the central portions of their bottom edges **56** are sewn to the long sides, or edges **62**, **64** of base panel **26**, and the end portions are sewn to the half-width portions of end edges **66**, **68** of base panel **26**. The closure member **28** has the form of zipper assembly **30** as noted above. Zipper assembly **30** has a first side region **84**, a second side region **86**, and a zipper **88**. Side region **84** has an outboard, or distal edge seamed into front panel **22**, and an inboard edge, or margin, to which one set of teeth of zipper **88** is mounted. Side region **86** has an outboard, or distal edge that is seamed into rear panel **24**, and an inboard edge along which the other set of teeth of zipper **88** is mounted. In the usual manner, motion of zipper car **90** along the track defined by the zipper teeth controls the opening and closing of the zipper assembly, and hence controls access to the enclosed space **25** of bag **20** more generally, thereby permitting objects to be introduced into, or to be drawn out of, bag **20**. Side regions **84** and **86** each have an upper, load bearing web member **92**, **94** and an inner wall member **96**, **98**. In one embodiment of the invention, inner wall members **96**, **98** may be reflective, or have a reflective inwardly facing (i.e., inward relative to the

enclosed space **25** of bag **20** so that the reflective surface is oriented toward objects contained in bag **20**) surface, and may preferably be made of “thermoflect” (t.m.) material. In another embodiment, inner wall members **96, 98** is a white, water proof nylon sheet. The seaming of the side region of zipper assembly **30** occurs at a height downset from the very edge of the side wall panels by a distance  $\delta$ , roughly equal to the half width  $\delta_2$  of zipper assembly **30** such that when bag **20** is folded, side regions **84** and **86** may tend to fold next to those margins, rather than to protrude excessively.

The overall width of the web-like region, or panel formed by zipper assembly **30** is less than, if not significantly less than, the width of panel **26** such that the through thickness of bag **20** at the elevation of closure member **28** is small, if not very small, relative to the length of closure member **28**, and relative to the length of upper marginal edge **54**. It is preferred that the overall width of the closure member be less than 60% of the width of the base, and, in a particular example, is about half the width. As such, the ratio of through thickness to bag length may be about  $a_2 / (2a_2 + b)$ . This value may typically lie in the range of 1 : 5 to 1 : 8 and more narrowly in the range of 1 : 6 to 1 : 7  $\frac{1}{2}$ . The closure member is mounted between the upper margins of the side wall panels, namely panels **22** and **24**, and, when open, permits at least central portions of those margins to be moved closer together or further apart as may be desired to give access to the enclosed chamber.

The sidewall construction is as shown in Figure 5. Each of sidewall panels **22, 24** has a relatively wear resistant outer membrane or sheet, or web **80**, that may be made of a sheet or woven webbing fabric, such as woven nylon, canvas, or other suitable cloth. Each of sidewall panels **22, 24** also has an inner sidewall membrane, or sheet, or web **82**, that may function as a water proof lining, and may be made of a sheet of extruded plastic of the types of polymers that include vinyl (t.m.) or nylon (t.m.), or sheets of monolithic extruded vinyl (t.m.) or nylon (t.m.) sewn together.

An insulating layer **84** is trapped between the inner and outer webs **82** and **80**. Insulating layer **84** may preferably be a closed cell polyurethane foam, but could be an open cell insulating foam, or other type of insulating layer, or it may include more than one insulating layer.

As above, in one embodiment the inner sidewall web member may either be made of a reflective material, such as thermoflect (t.m.) sheeting, or may have a reflective surface oriented to face toward objects contained within bag **20**. Alternatively, inner web **82** member may be made of a water proof extruded nylon or vinyl sheet, or seamed sheets, to discourage leakage of liquids from bag **20**.

Optionally, water-proof liner **32** may be included, in addition to the internal sidewall web sheet, namely, web **82**. Where the inner sidewall surface is reflective, the liner may preferably be translucent, or clear, to permit the reflective surface of the inner wall to be seen. Although the liner can be rigidly sewn in place to prevent the liner from being inverted, it is preferable for the liner to be either removable, or to be sewn in at its upper peripheral edges, thus permitting at least partial inversion of the liner as shown in Figure **7a**, and hence to facilitate washing. The optional liner **32** may be made from a single polymer sheet, have a first side region **88** and a second side region **90**. The side regions are heat welded along their side margins to form a pouch, or pocket, commensurate with the general size and shape of the inside of bag **20**, and have their upper margins seamed into the sidewalls of bag **20** at the juncture with the side regions of zipper assembly **30**. Bag **20** will then tend to be water-proof to a height corresponding to the height of closure member **28**. It is advantageous, and desirable, for a soft sided insulated wall assembly for use as a cooler, such as bag **20**, to be generally leak resistant, if not even more preferably, water-proof.

The cross-sectional structure of base panel **26** is generally similar to the cross-sectional structure of the sidewall panels, having an inner wall skin, or panel or web **114** that is of consistent construction to the inner wall sheet or web **82**, and an outer wall skin, or web **116** that is of consistent construction to outer web **80**. It may be noted that the outer web **80** may not be the same colour as outer web **116**, and may not be of the same weave or fabric. It may have a heavier, more wear resistant fabric, or coarser, more wear resistant weave, since base panel **26** may tend to be placed in contact with the ground, or other underlying surface whether a paved roadway, concrete, rocks, earth, flooring, or some other support surface against which it may be expected to be slid, or to rub, in the course of use.

Base panel **26** may also have an insulated layer, **118**, captured between webs **114** and **116**, the insulated layer being made of an insulated foam, or other suitable heat transfer resistive medium as described above. In addition, base panel **26** has a stiffened form

member **120**, that may be in the nature of a rectangular, hard plastic sheet **100** of modest thickness located between insulating layer **118** and outer web **116**. Sheet **100**, in plan view, has dimensions that are the same as, or roughly the same as, dimensions 'b' and 'w'. Form member **120** serves two functions, the first being to provide a stiffened base upon which bag **20** can tend preferentially to stand, and which may tend to aid in discouraging bag **20** from tipping over as easily as it might otherwise do. The second is to provide a forming edge to base **26** by which to pre-determine the fold line, or lines, at which bag **20** will tend to want to bend when being folded up. This may tend to discourage the tight-rolling of bag **20**, and to encourage repeatable panel folding to and from the convenient folded form shown in Figures **3a – 3g**.

Form member **120** need not be a continuous monolithic panel. It could be an open frame, or a peripheral member sewn in place to provide a reinforced edge. In one embodiment, even without form member **120**, the seaming at the edge of insulated base panel **26** may tend to yield a natural fold location at which bag **20** may tend to prefer to bend or fold. The inclusion of member **120** may tend to strengthen or to enhance this tendency. Modestly sized feet, stand offs, or pads, **102**, may optionally be provided to the underside of panel **26**. Further, form member **120** may, by itself, tend to have a greater flexural stiffness than the adjacent layer of insulated material, and when taken together the resultant bi-laminar, or possibly multi-layered assembly, has a combined flexural stiffness that may tend to be significantly stiffer than any other portion of bag **20**.

Lifting members, or carrying members, in the nature of straps, or web bands **46, 48**, are sewn up the outside faces of side wall panels **22** and **24**, having their roots at the seamed junction between bottom panel **26** and the side wall panels **22, 24**. Each of bands **46, 48** has a central portion **104, 106** that extends upwardly beyond the upper margins of the sidewall panels to provide a grasping, or carrying portion that can be held or placed over a user's shoulder, as in Figure **1**.

Auxiliary securement straps **50, 52** have a root end sewn into the upper region of the seam between panels **22** and **24**, at a height near the height of closure member **28**. The distal ends of straps **50, 52** bear velcro patches **110**, suitable for securing in to the trunk fabric of an automobile (or, alternatively, mating velcro patches can be mounted inside the automobile for this purpose). When not in use, the ends of straps **50, 52** mount to mating velcro patches

**112** located on the outward face of front side panel **22**. Straps **110** could as easily be oriented to face in the other direction, and to mate with patches sewn on rear panel **24**.

### Alternate Embodiments

5

In the alternate embodiment of Figure **9a**, an alternate insulated base panel **126** has the same structural and thermal properties as base panel **26** in general, but differs in that rather than being rectangular in plan view, base panel **126** has a length, or long dimension, indicated as ' $b_2$ ' and a width indicated as ' $w$ '. These dimensions need not be the same as ' $b$ ' and ' $w$ ' indicated above, but may be. In this case the ends of panel **126** are not squared, but rather are mitred at an angle  $\alpha$  relative to the perpendicular to the long edges. The length along each of the mitred edges is then given as ' $a_2$ '. In this case the half width of base panel **126** is not  $a_2$ , but rather  $a_2 \cos\alpha$ . The periphery of base **126** is  $2(b_2 + 2a_2)$ .

10

15

The adjoining side panels are again taken to be ' $X$ ' wide, and ' $Y$ ' high, and to be of the same general insulated construction as side wall panels **22** and **24**, as shown, for example, in Figure **5**. The length of the lower margin **124** of each of the adjoining side panels **122** is then  $(b_2 + 2a_2)$ . Each panel will then have a "large fold" **128** and a "small fold" **130**. Large fold **128** is a nominal indication of where there would be a fold in the side wall of the bag in the fully unfolded condition ready for filling with diverse objects, if a sharp crease were made. In actual use, the corner will not be creased, but rather will tend to take on a more rounded, or radiused form, and the bag will tend to conform to the shape and bulkiness of objects placed in it, so the actual corner of the bag may have a bulging appearance rather than a sharp corner. Small fold **130** indicates the actual location of a fold that is made when the bag is in a collapsed state and folded for storage.

20

25

The angle  $\beta_1$  of small fold **130**, when the bag is folded for storage, will then tend be roughly equal to the bisector of the angle between the extension of the horizontal fold line defined by the edge of base **126** and the mitred edge, namely  $\frac{1}{2}(90 - \alpha)$ .

30

Base panel **126** need not necessarily be a straight sided polygon, as are base panel **26**, but could have somewhat rounded, oval or irregular ends. However, in such a case the end fold may tend to be puckered, and may tend not to lie as flat as might otherwise be considered desirable or preferable. However, a straight sided polygon is advantageous, and a

square-cornered (i.e., rectangular) end is preferred since it may tend to facilitate manufacture and efficient use of materials and reduced waste cuts.

5 Bag **20** is a “double fold” bag. That is, base panel **26** is folded flat at a first fold (the offside edge of base panel **26**), and then side panels **22** and **24** are bent about the second fold (the nearside edge of base **26**). In alternate embodiments, a soft sided, collapsible and foldable insulate single-fold bag could be produced, or a triple-fold, or more, bag could be produced.

10 An example of a single fold bag **140** is shown in Figures **10a – 10g**, the views corresponding generally to the views of double fold bag **20** shown in Figures **3a – 3g** respectively. Except as otherwise indicated, bag **140** has the same general construction as bag **20**, having insulated side wall panels **142**, **144**, and an insulated base panel **146**, with a similar closure member **148** and optional liner similar to liner **32**. Bag **140** differs from bag  
15 **20** in being a single fold bag, rather than a double fold bag, and has changes in dimension and aspect ratios accordingly. In place of the arrangement of retention member **40**, a retention member **150** would might tend to be mounted near the lower margin of the front panel **142**, and another, mating, retention member **152** would be mounted near the upper edge of the front panel, the two mating when the base panel is moved to a collapsed position  
20 in which it is laid over against side panel **142**.

An example of a triple fold bag **160** is shown in Figures **11a – 11g**. Figure **11a** shows triple fold bag **160** in a collapsed, or flattened condition immediately prior to folding into the storage position (or, alternatively and equivalently, immediately after being  
25 unfolded, and before filling). Bag **160** is presented as being symbolic of not only a bag having three folds. In general, for a bag, such as bag **160**, having three or more folds, the retention member **178** would be located on the front face **164** roughly the width of two folded panel regions below the upper edge of the front face with the second retention member being mounted near or at the upper edge, such that, when folded the two parts **178**  
30 and **174** would tend to mate. An example of a single fold bag is illustrated in Figure **10a**. An example of a triple fold bag is shown in Figure **11a**.

In the examples discussed so far, the upper edge of a bag having rectangular sidewall panels is  $L_i = 2(a_i + b_i)$ , whether  $i$  is **1** or **2**. As shown in Figure **9b**, the side panels of bag

20 need not be made from rectangular sheets, but could be made from sheets that are of a different shape, such as the trapezoidal side panel sheets 180. In this case, the resultant bag 182 would tend to have an upper edge 184 for which the length  $L_2$  would tend to be greater than the sum of the  $b + 2a_i$ , or, put generically, where  $L_1$  is greater than half the total periphery of the base panel 186. This may tend to yield a more flared appearance when the bag is seen in an unfolded side view, and may tend to yield a larger access opening, such as may permit objects of greater relative size to be introduced into the insulated spaced.

Although the embodiments illustrated and described above are preferred, the principles of the present invention are not limited to these specific examples which are given by way of illustration. It is possible to make other embodiments that employ the principles of the invention and that fall within its spirit and scope of the invention. Since changes in and or additions to the above-described embodiments may be made without departing from the nature, spirit or scope of the invention, the invention is not to be limited to those details, but only by the appended claims.

**Claims**

I claim:

1. A foldable insulated bag comprising:  
5 an insulated wall structure, defining an insulated space therewithin;  
said wall structure having a closure member operable to govern access to said  
insulated space; and  
said wall structure including a forming panel;  
said wall structure, when empty, being movable to a first, flattened position;  
10 said wall structure being foldable about at least a portion of said forming panel to a  
folded storage position;  
said wall structure being securable in said folded storage position; and  
said forming panel including a stiffener member.
- 15 2. The foldable insulated bag of claim 1 wherein said bag is a double fold bag.
3. The foldable insulated bag of claim 1 wherein said bag includes a retainer, said  
retainer being operable to secure said bag in said folded storage position.
- 20 4. The foldable storage bag of claim 1 wherein said bag has a bottom region and a top  
region, and a suspension member is mounted distant from said bottom region.
5. The foldable insulated bag of claim 1 wherein said forming panel has a flexural  
rigidity greater than any other portion of said bag.
- 25 6. The foldable insulated bag of claim 1 wherein said forming panel has an insulating  
layer and a stiffening layer.
7. The foldable insulated bag of claim 1 wherein said forming-panel stiffener member  
30 includes a stiffened straight edge.
8. The foldable insulated bag of claim 1 wherein said forming-panel stiffener member  
includes a pair of spaced apart, parallel stiffened straight edges.

9. The foldable insulated bag of claim 1 wherein said bag has a base panel and a sidewall structure mounted about said base panel, said forming panel being said base panel.

5 10. The foldable insulated bag of claim 9 wherein said sidewall structure includes first and second opposed sidewall panels, each sidewall panel having a first edge adjoining said base panel and a second edge distant therefrom, said closure member being mounted to said distant edges.

10 11. The foldable insulated bag of claim 9 wherein said sidewall structure includes first and second opposed sidewall panels, each sidewall panel having a first edge adjoining said base panel and a second edge distant therefrom, said side wall panels having an altitude measured between said first and second edges, and said base panel having a width measured between junctures of said adjoining edges of said sidewall panels therewith, said altitude having a magnitude X, and said width having a magnitude Y wherein X has a value lying on  
15 one of the ranges chosen from the set of ranges consisting of

- (a) 0.8 Y to 1.2 Y;
- (b) 1.8 Y to 2.2 Y; and
- (c) 2.8 Y to 3.2 Y.

20 12. The foldable insulated bag of claim 9 wherein:  
said foldable insulated bag having a retainer operable to secure said foldable insulated bag in said folded storage position;  
said sidewall structure includes first and second opposed sidewall panels, each said sidewall panel having a first edge adjoining said base panel and a second  
25 edge distant therefrom;  
said base panel has a first edge connected to said first sidewall panel, and a second edge connected to said second sidewall panel;  
said base panel has an outer face, and an inward face;  
in said flattened position said first edge of said base panel lying nearer than said  
30 second edge of said base panel to said second edge of said first sidewall panel;  
said outer face of said base panel having a first member of said retainer mounted thereto adjacent to said second edge thereof;  
said first sidewall panel having a second member of said retainer mounted adjacent  
35 to said second edge thereof; and

said base panel being movable to bring said first portion of said retainer into mating engagement with said second portion of said retainer.

- 5 13. The foldable insulated bag of claim 12 wherein said first and second members of said retainer are mating hook-and-eye fabric strip portions.
- 10 14. The foldable insulated bag of claim 9 wherein:  
said sidewall structure includes first and second opposed sidewall panels, each said sidewall panel having a first edge adjoining said base panel and a second edge distant therefrom;  
said base panel has a periphery, said periphery including a first edge adjoining said first edge of said first sidewall panel, and a second edge adjoining said first edge of said second sidewall panel;  
said periphery including two opposed remainder portions between said first and  
15 second edges, said portions having lengths  $2a_1$  and  $2a_2$  respectively;  
said first edge of said first sidewall panel having a length,  $L$ ;  
said first edge of said base panel having a length  $b$ ; and  
said length  $L$  being at least as great as  $b + (a_1 + a_2)$ .
- 20 15. The foldable insulated bag of claim 14 wherein said first edge of said first sidewall panel is centered relative to said first edge of said base panel.
- 25 16. The foldable insulated bag of claim 9 wherein:  
said sidewall structure includes first and second opposed sidewall panels, each said sidewall . panel having a first edge adjoining said base panel and a second edge distant therefrom;  
said base panel is rectangular, having two opposed sides of length  $b$  and two opposed sides of length  $a$ ;  
said first edge of said first sidewall panel has a length,  $L$ ; and  
30 said length  $L$  being at least as great as  $b + 2a$ .
17. The foldable insulated bag of claim 16 wherein each said first edge of said first sidewall panel is centered relative to the corresponding side of length  $b$  of said base panel.

18. The foldable insulated bag of claim 9 wherein said sidewall structure includes equal sized first and second opposed sidewall panels, each side wall panel having a first edge adjoining said base panel and a second edge distant therefrom.

5 19. The foldable insulated bag of claim 18 wherein said first edges of said first and second sidewall panels have a length L1, and said second edges of said sidewall panels have a length L2, where L2 is at least as great as L1.

10 20. The foldable insulated bag of claim 18 wherein each of said sidewall panels has a second edge distant from said first edge thereof, and said second edges of said sidewall panels are each longer than said base panel.

15 21. The foldable insulated bag of claim 9 wherein:  
said sidewall structure includes a pair of opposed first and second sidewall panels;  
said first and second sidewall panels each including a first edge mounted to said base  
panel,  
a second edge opposed to and distant from said first edge, a third edge, and a fourth  
edge;  
said fourth edge is opposed to said third edge;  
20 said respective third edges are mutually attached; and  
said respective fourth edges are mutually attached.

25 22. The foldable insulated bag of claim 1 wherein said insulated bag includes a waterproof liner.

23. The foldable insulated bag of claim 1 wherein said insulated bag includes a reflective interior surface oriented to face toward objects placed in said insulated space.

30 24. A foldable insulated bag comprising:  
a first side panel,  
a second side panel, and  
a base panel;  
at least said first side panel and said second side panel being insulated;  
at least said first side panel and said second side panel being pliable;  
35 said first side panel, said second side panel and said base panel co-operating to  
define an enclosed, insulated space;

said first side panel having a first base edge adjoining said base panel;  
said second side panel having a second base edge adjoining said base panel;  
said first side panel having a first distal edge opposite to said first base edge;  
said second side panel having a second distal edge opposite to said second base edge;  
5 at least a portion of said first distal edge being movable relative to at least a portion  
of said second distal edge to permit access to said enclosed insulated space;  
a closure member mounted to govern access to said enclosed, insulated space;  
said base panel having a length and a width, said length being greater than said  
width;  
10 said first distal edge of said first side panel being longer than said base panel;  
said base panel has a first edge connected to said first side panel and a second edge  
connected to said second side panel;  
said foldable bag being moveable to a first flattened position; and  
said first edge of base panel lies nearer than said second edge of base panel to said  
15 first distal edge of said first side panel in said first flattened position.

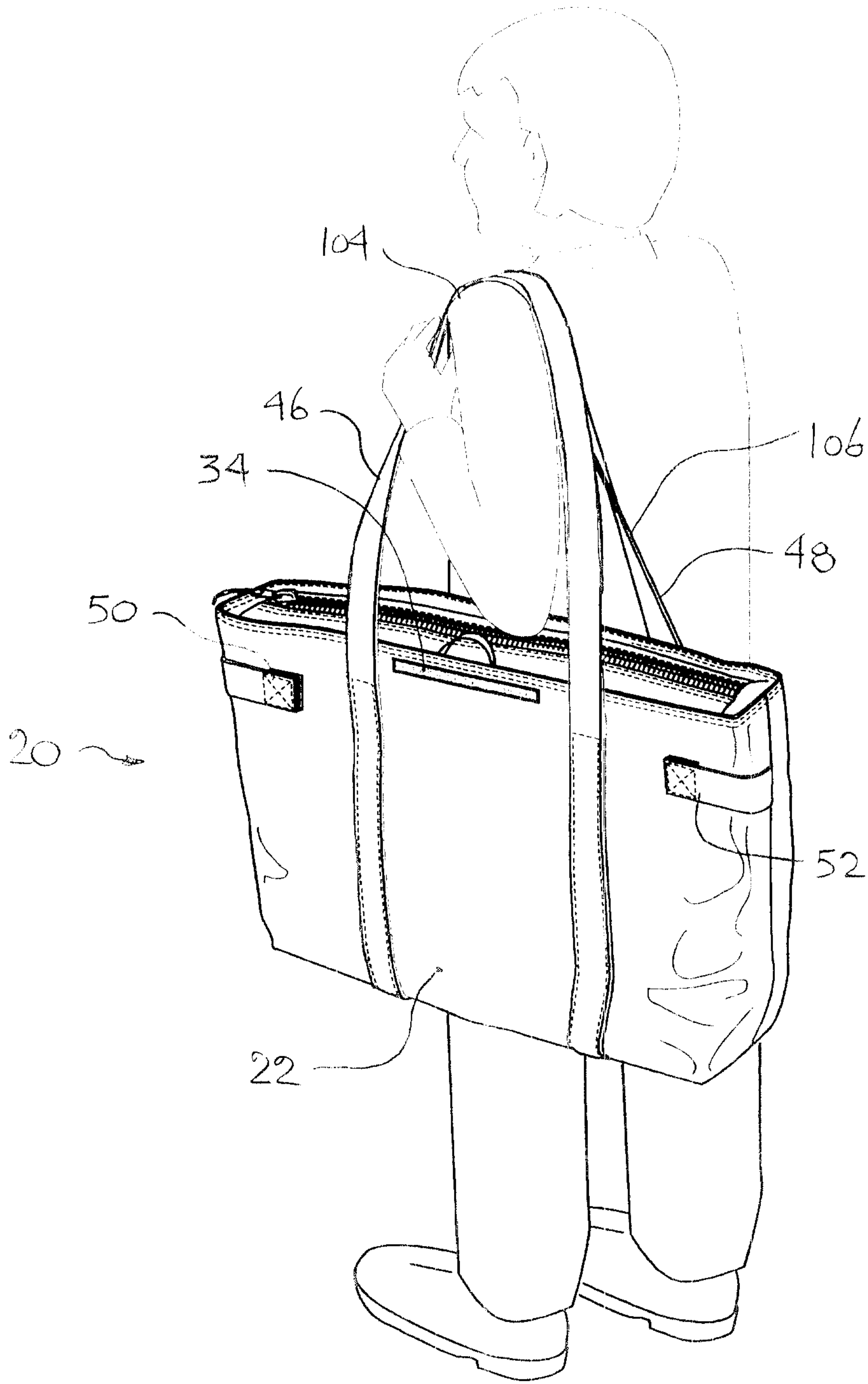

FIGURE 1.

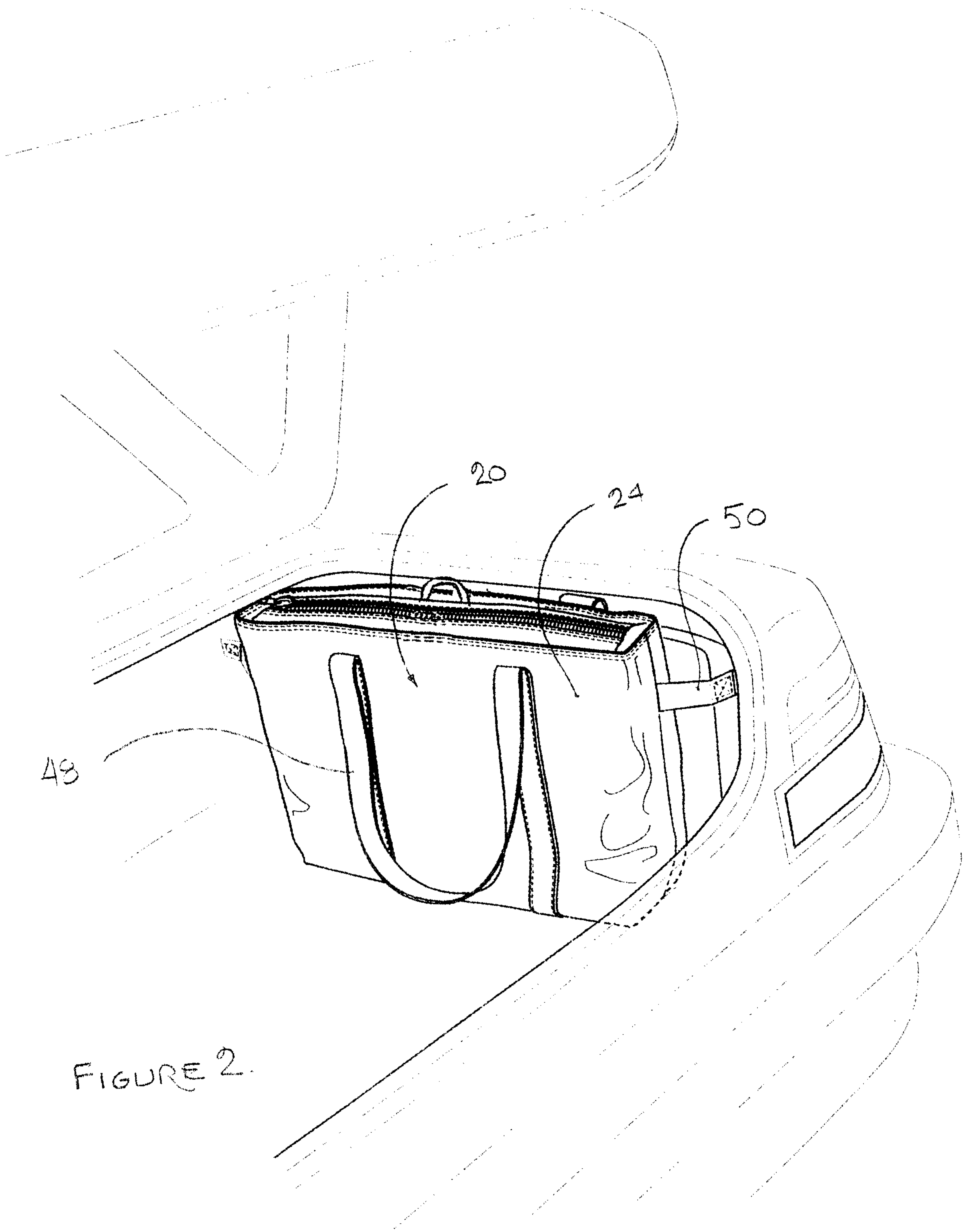

FIGURE 2.

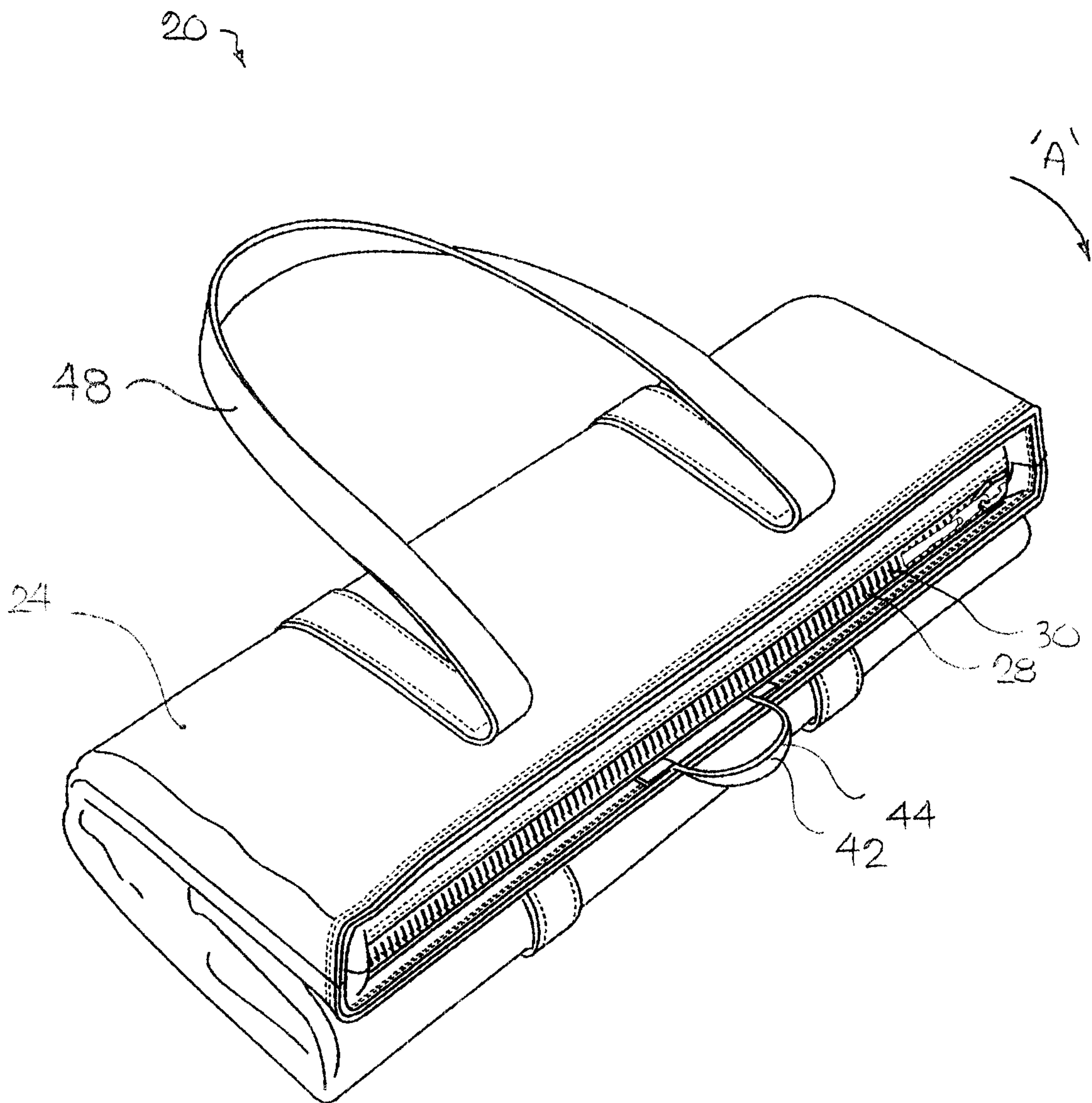

FIGURE 3a.

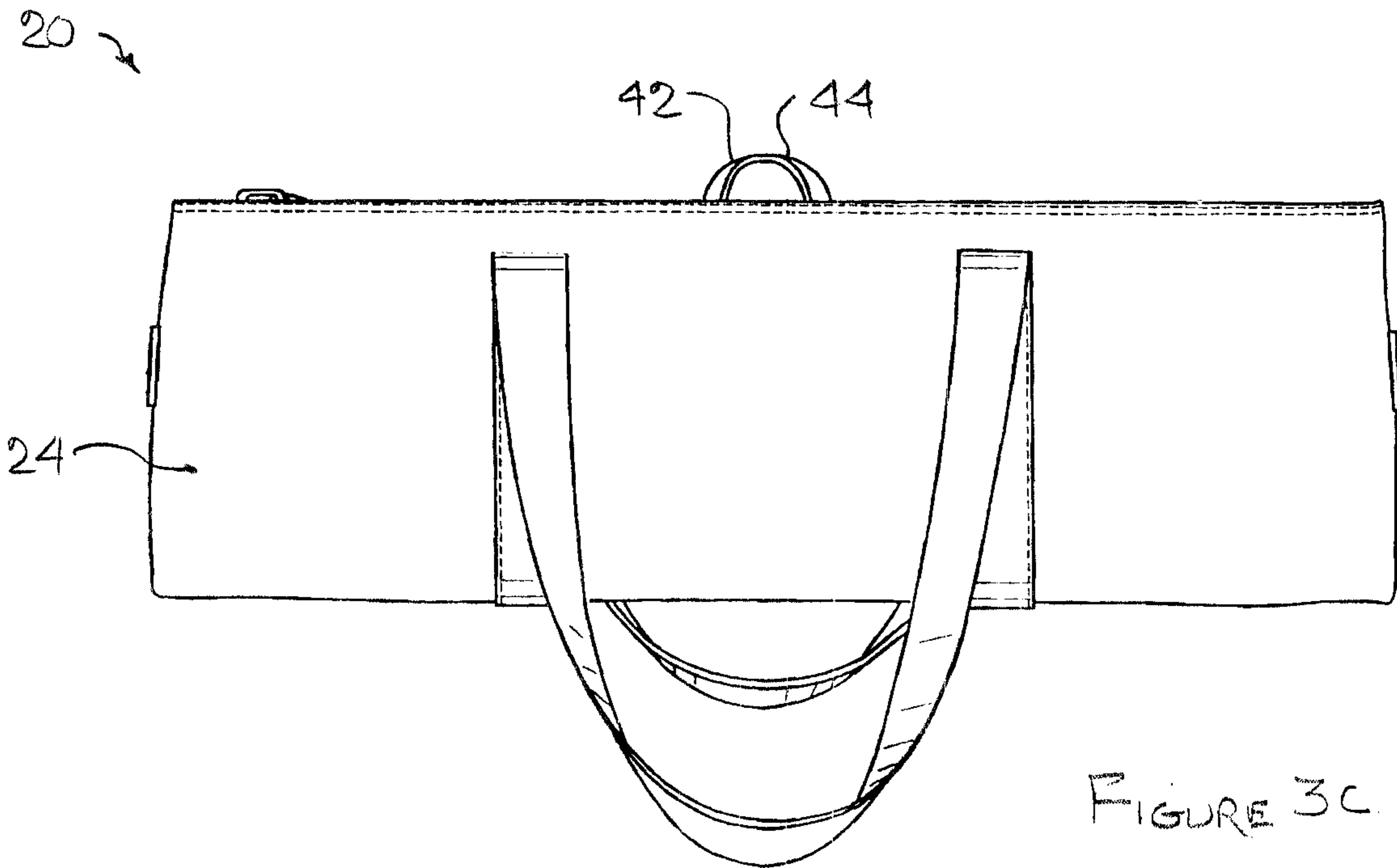

FIGURE 3c.

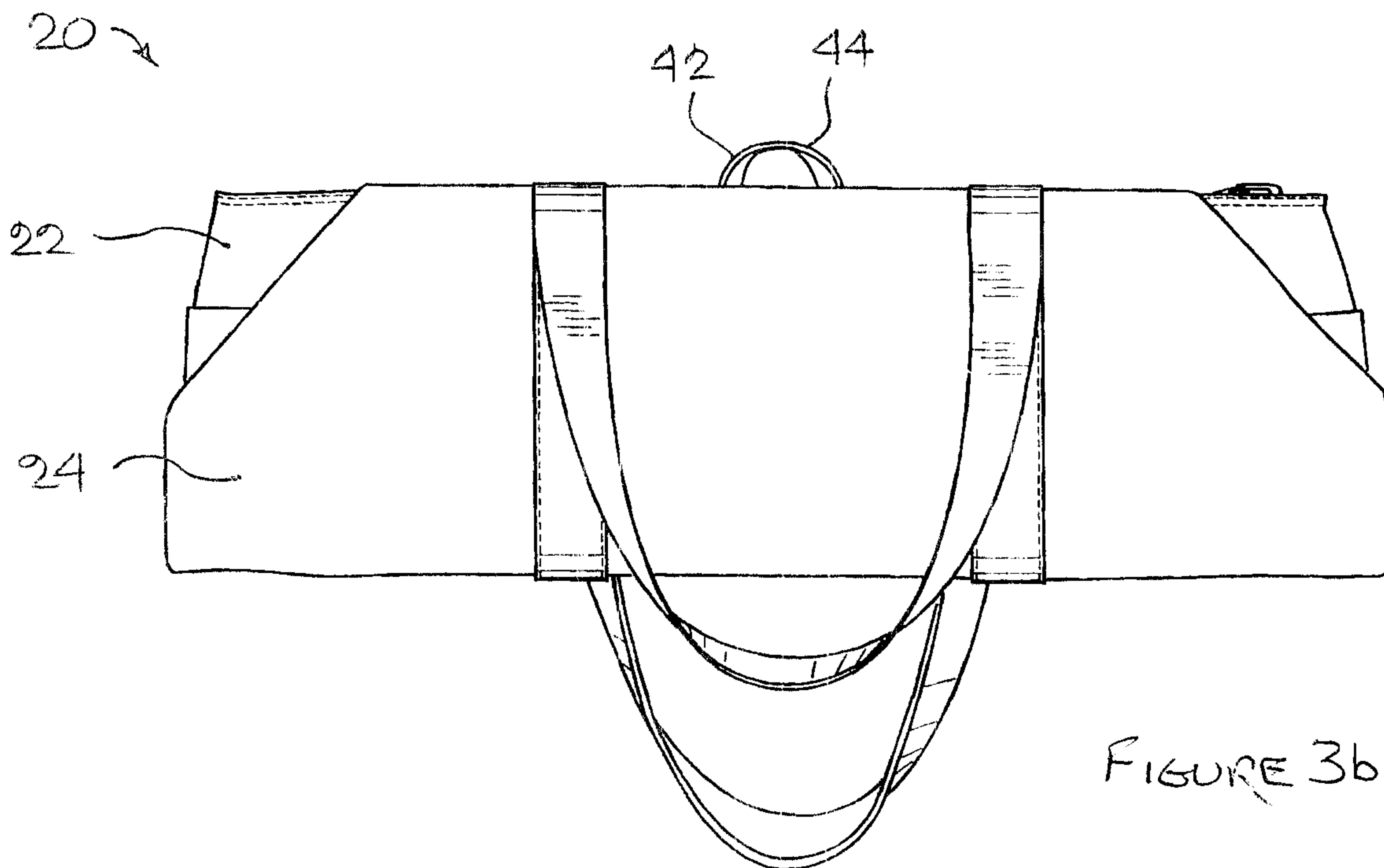

FIGURE 3b.

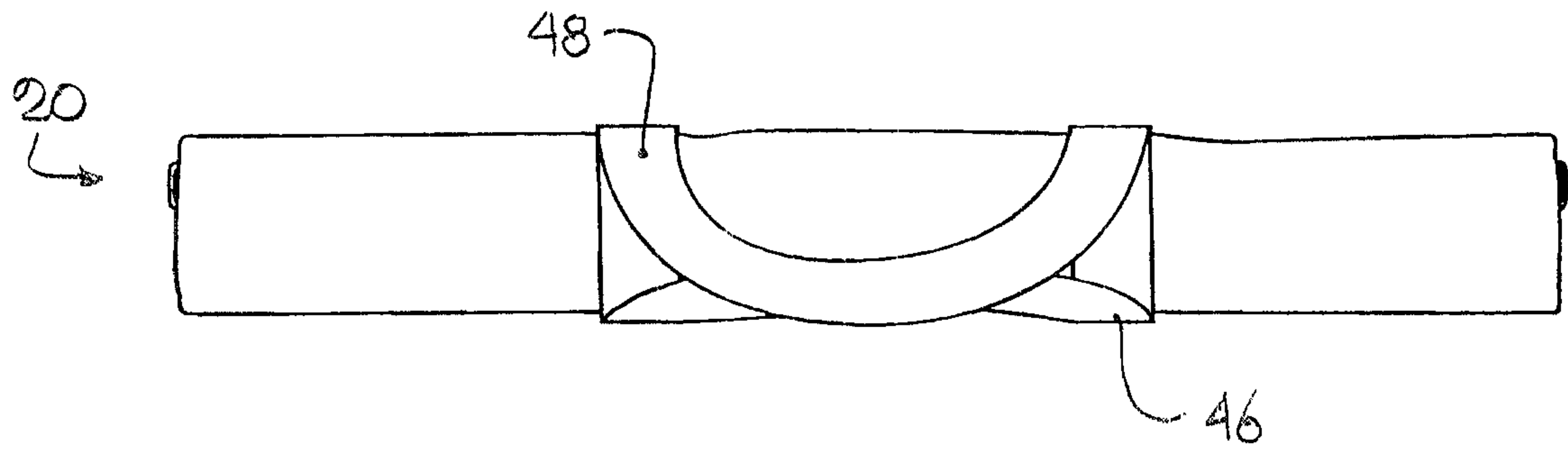

FIGURE 3g

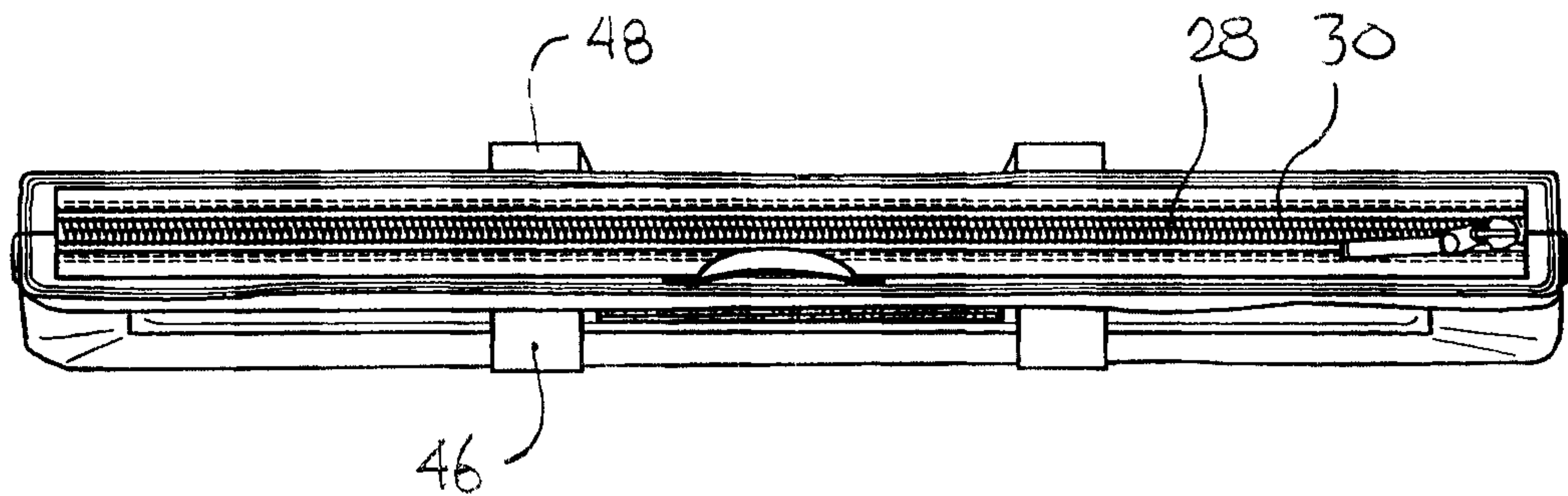

FIGURE 3f

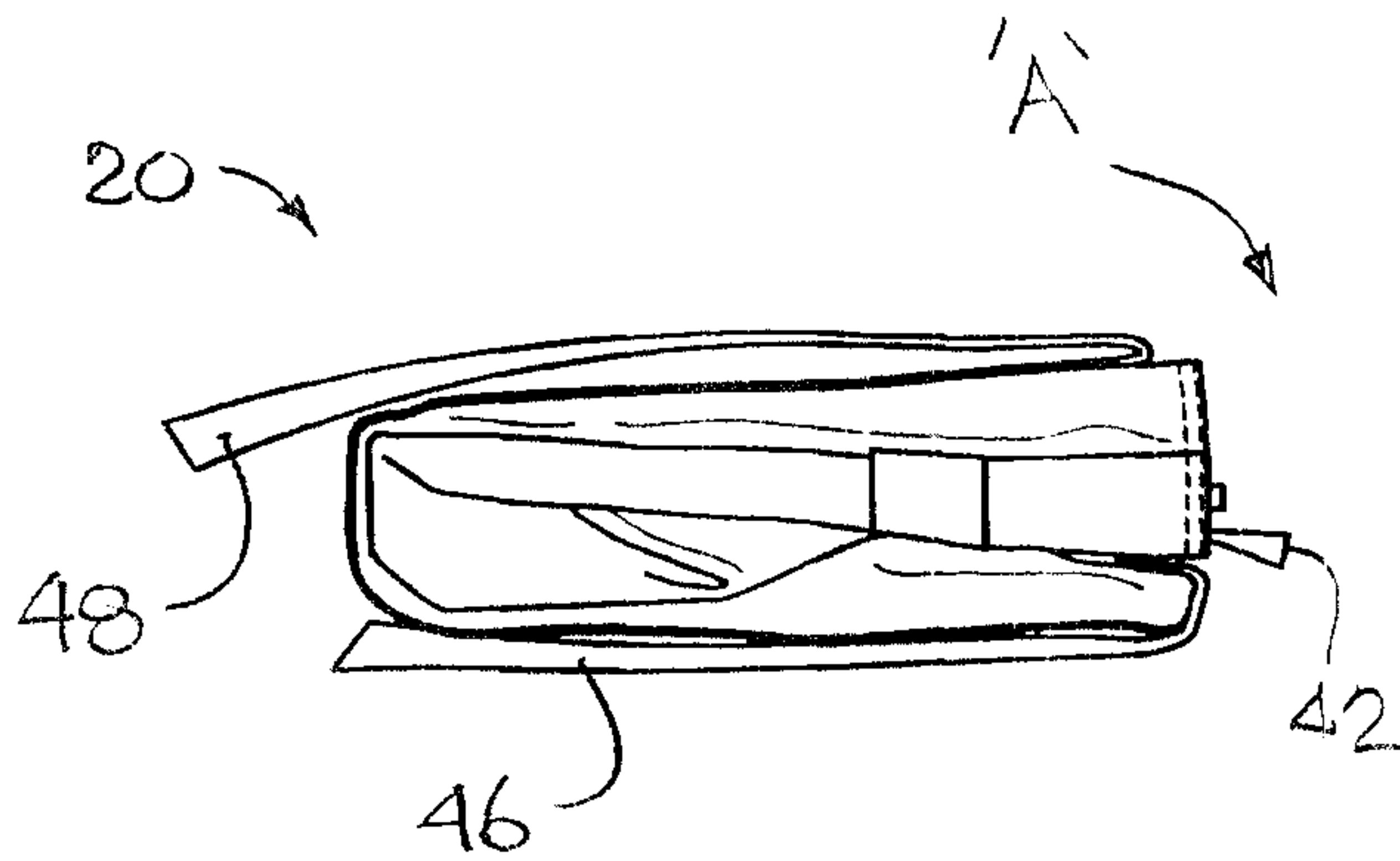

FIGURE 3e

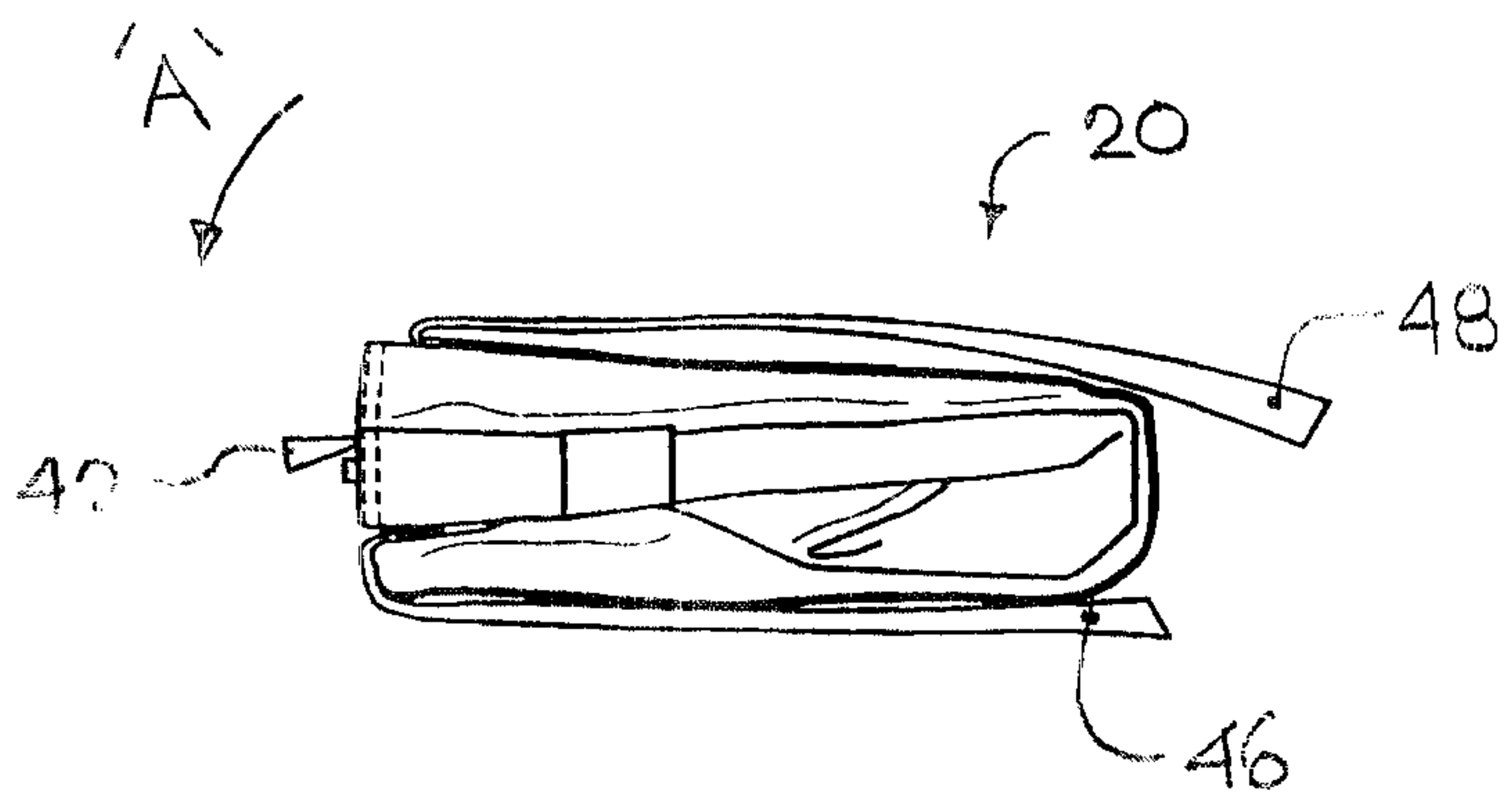

FIGURE 3d

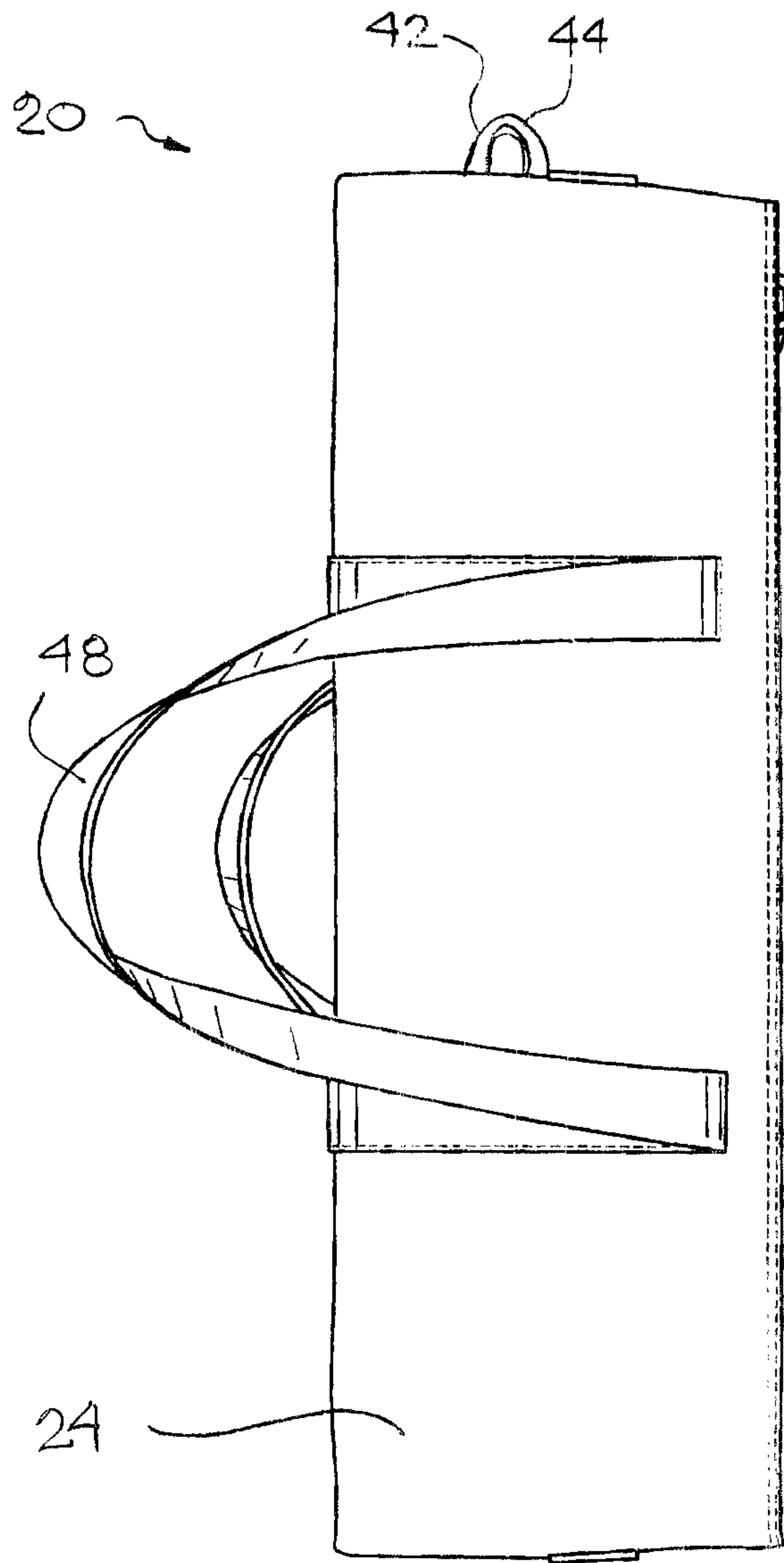

FIGURE 3h.

207

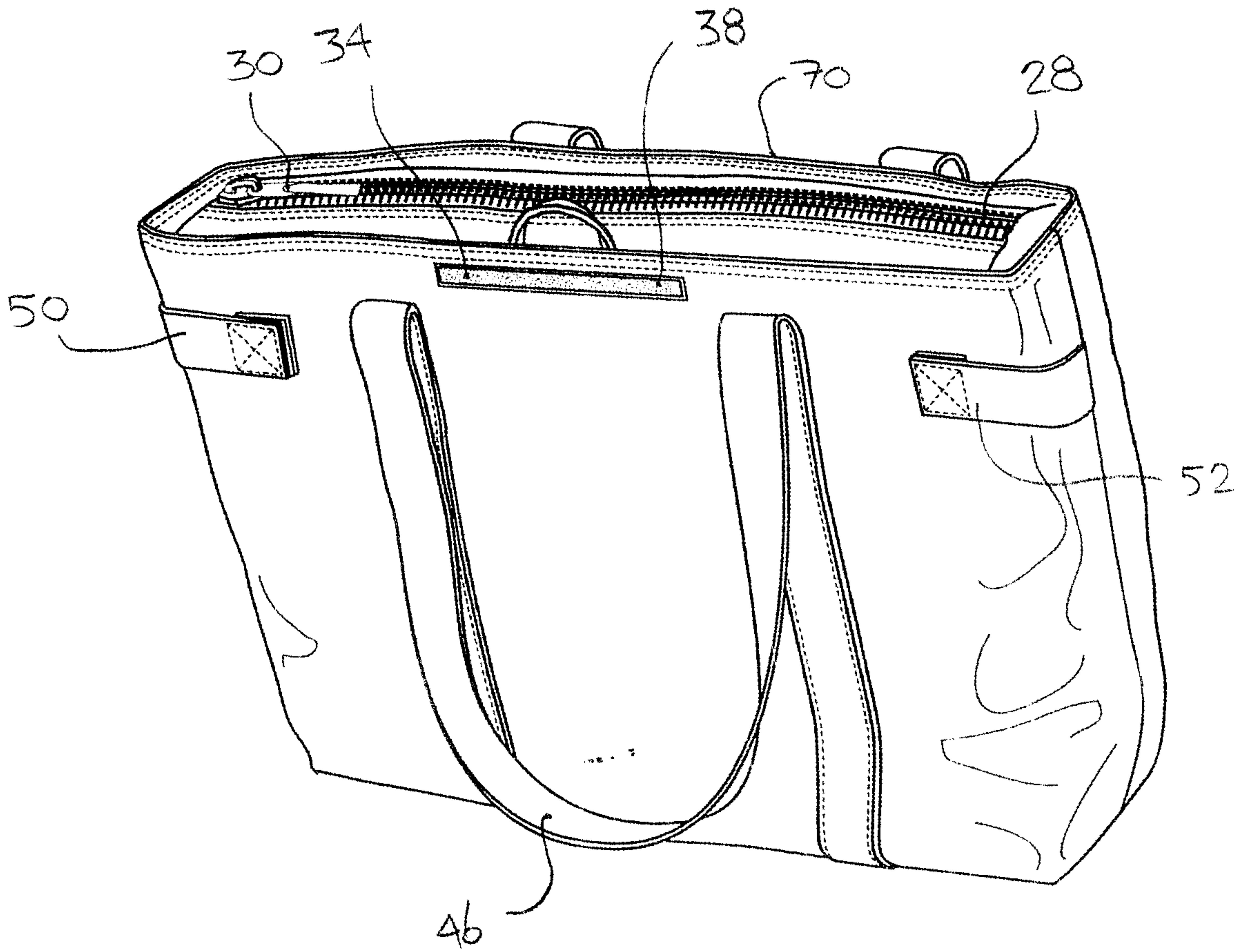

FIGURE 4a.



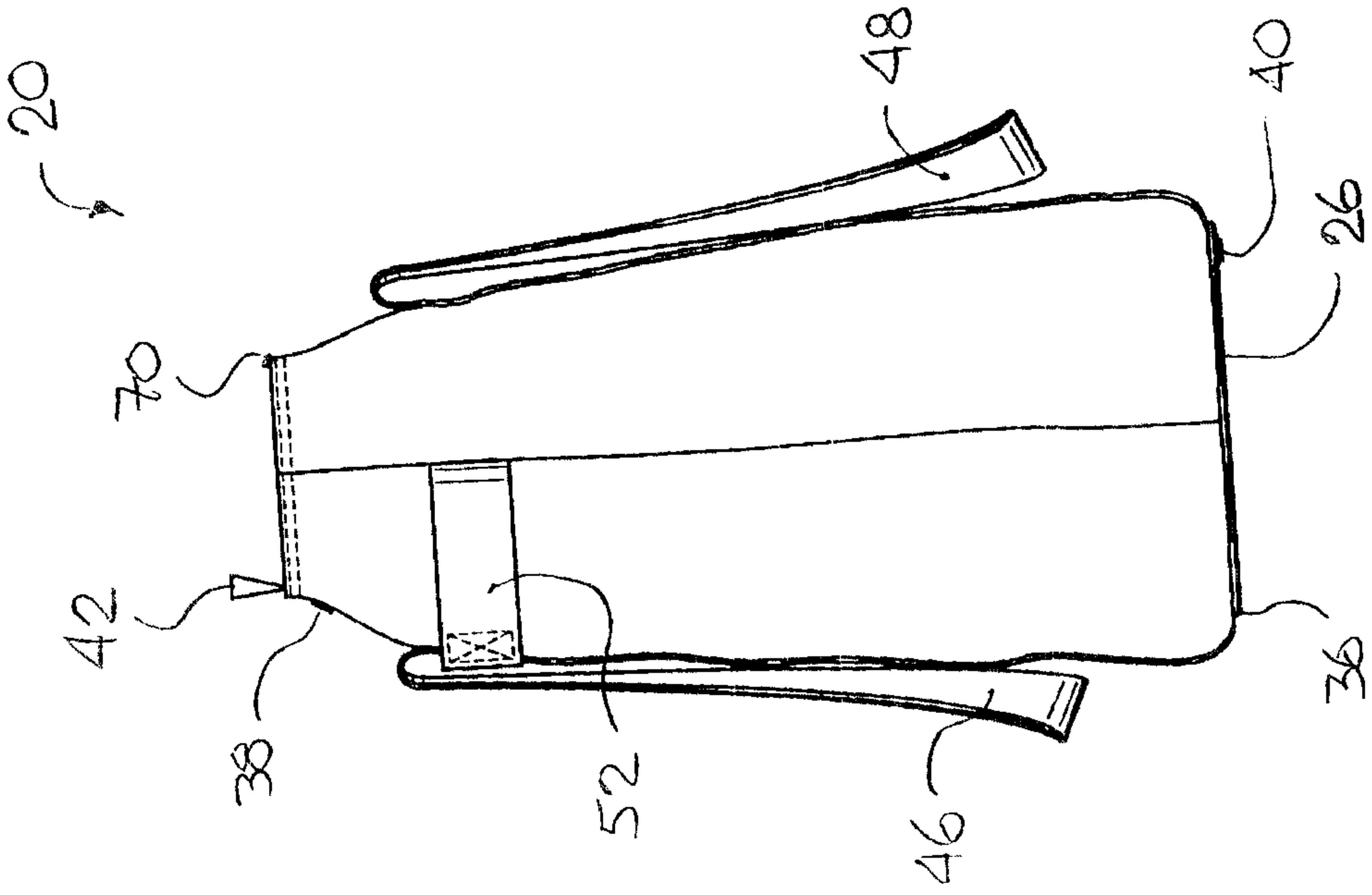

FIGURE 4e.

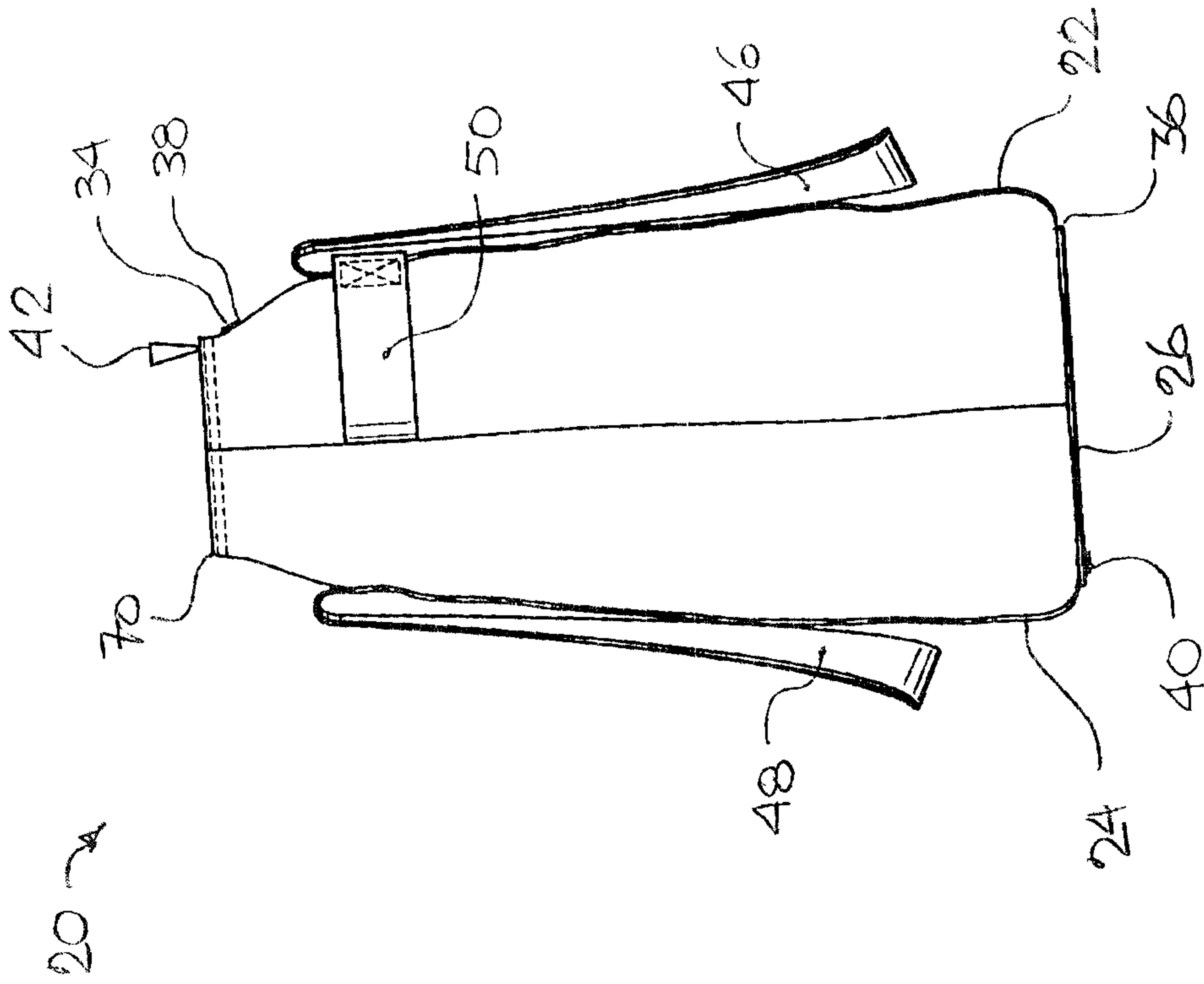

FIGURE 4d.

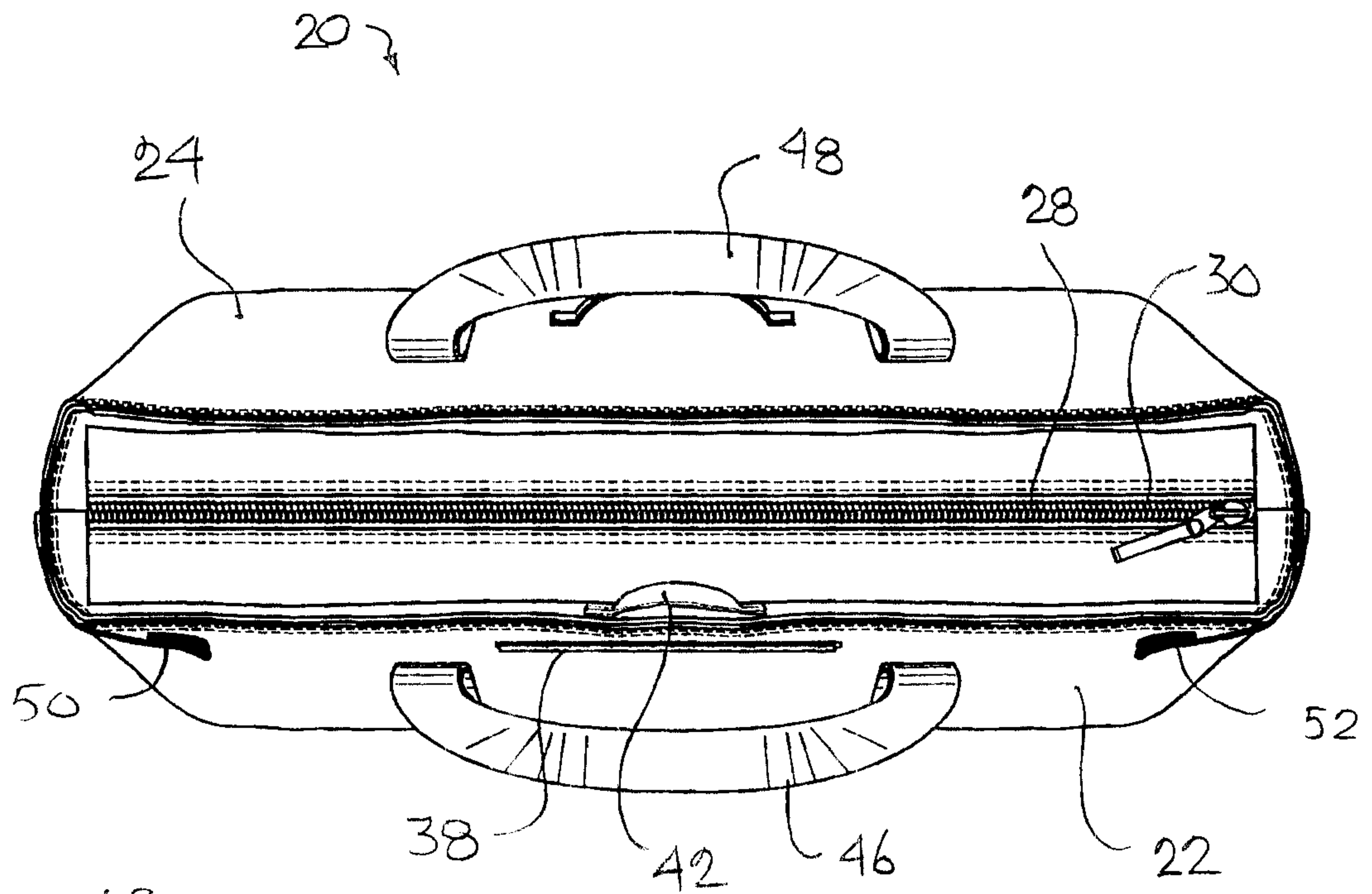

FIGURE 4f

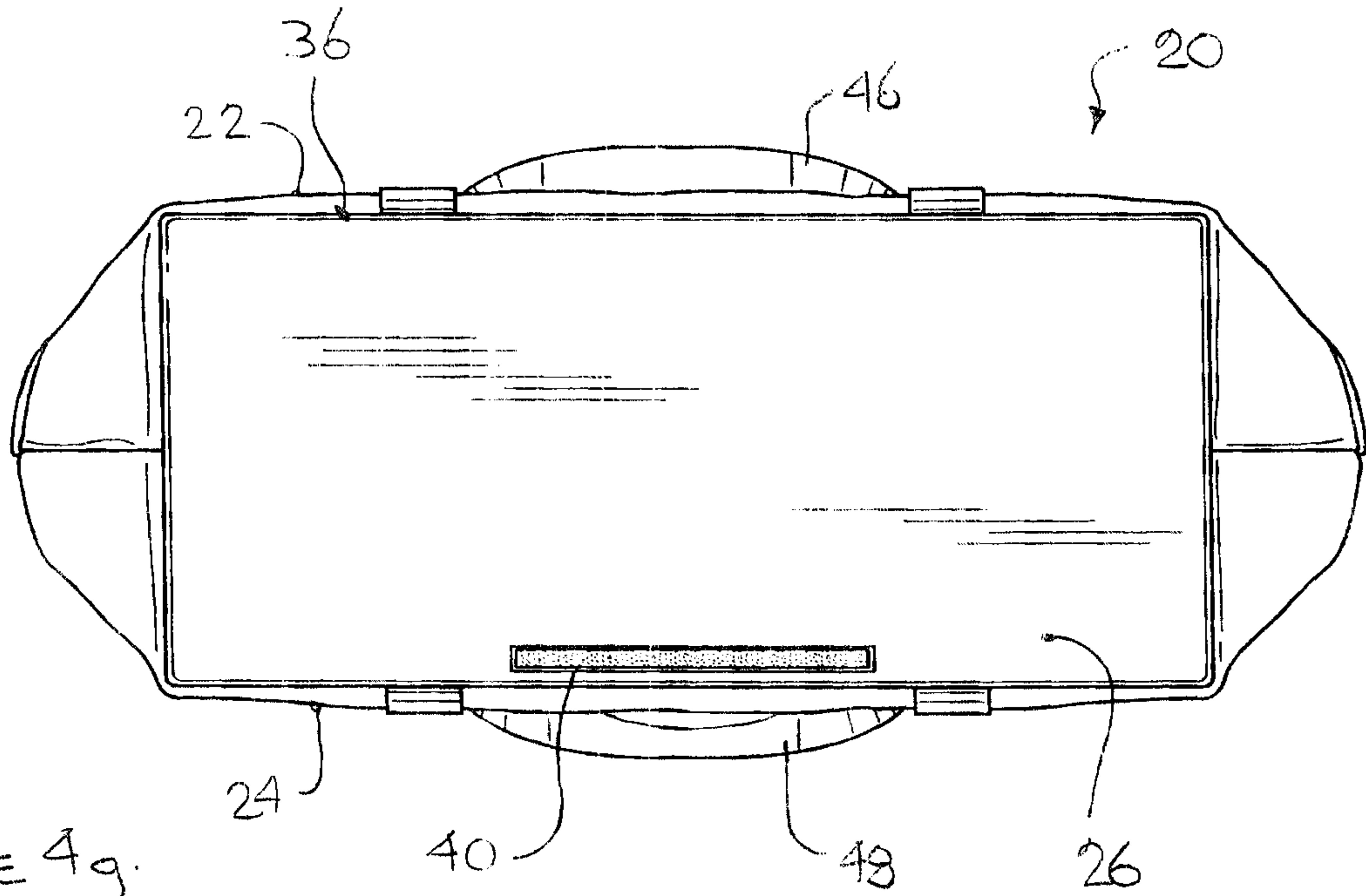

FIGURE 4g.

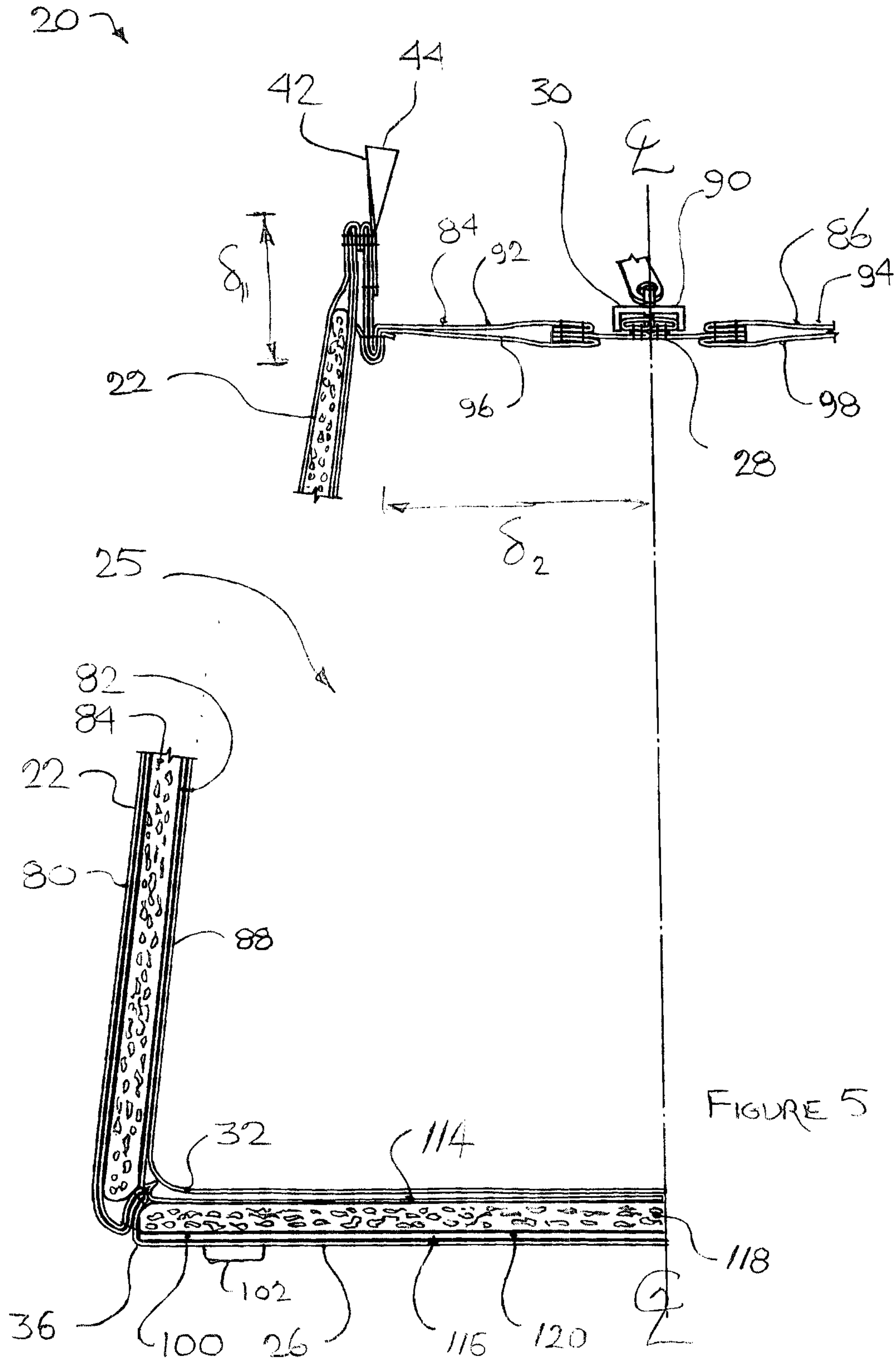

FIGURE 5

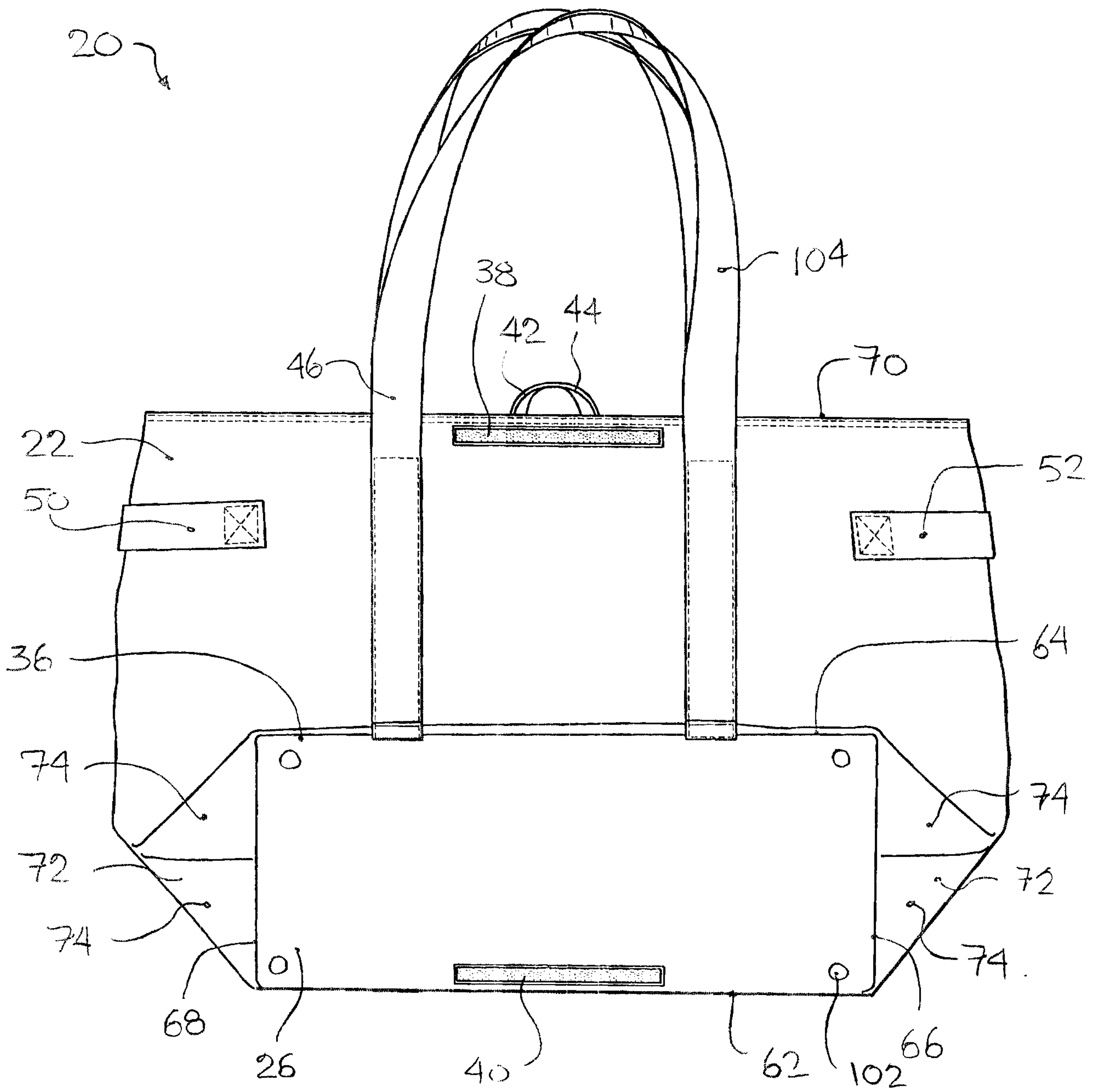

FIGURE 6a.

20 ~

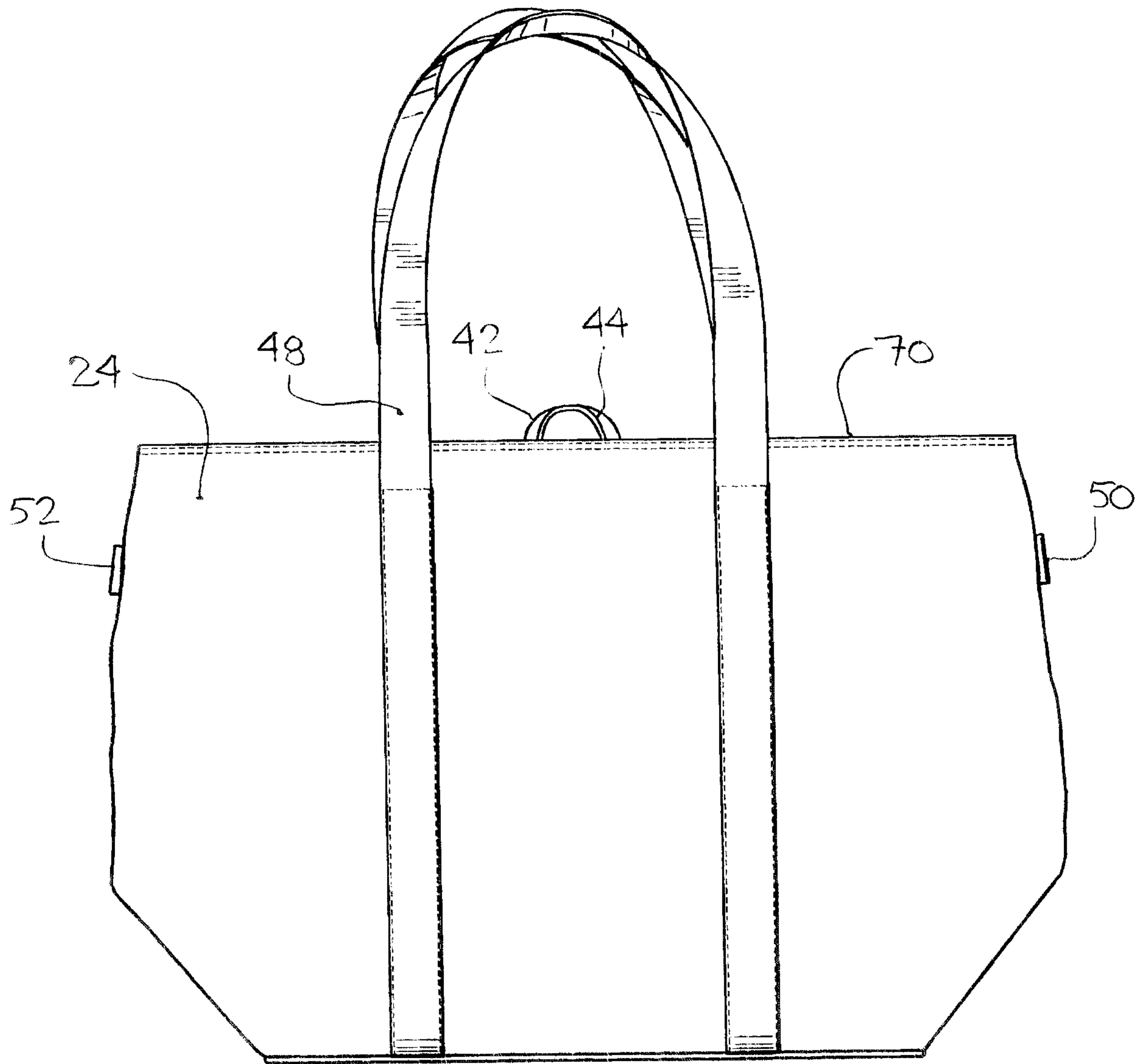

FIGURE 6b.

FIGURE 6d.

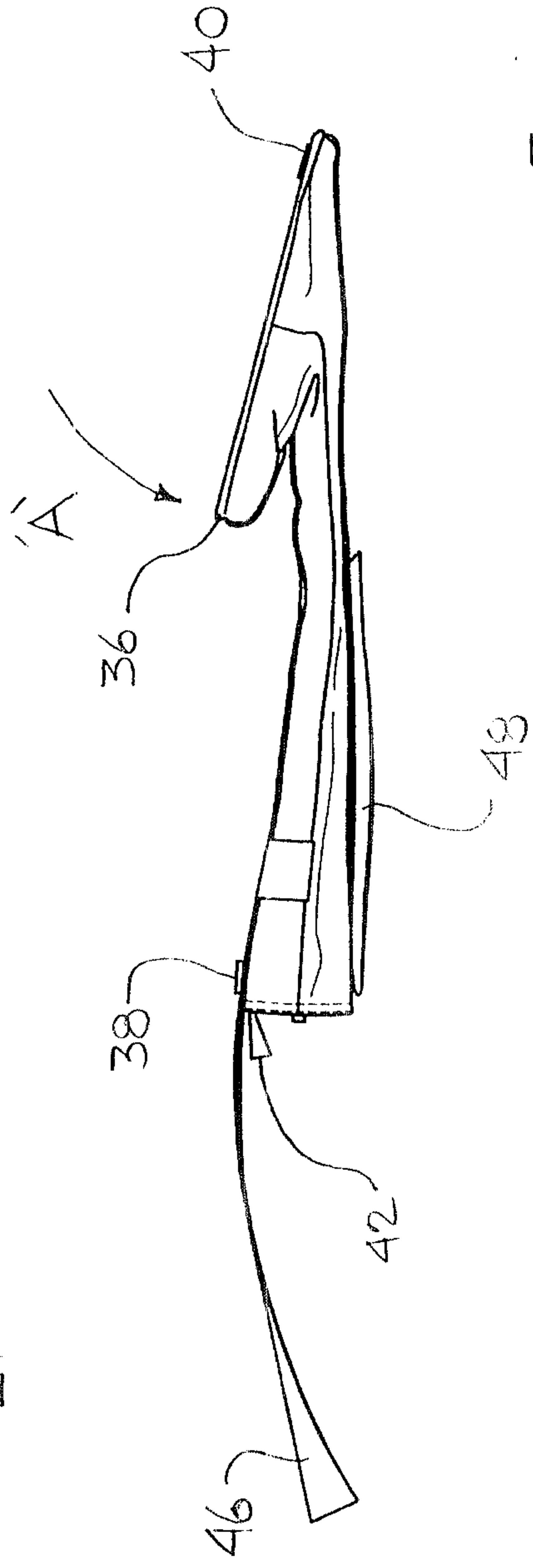
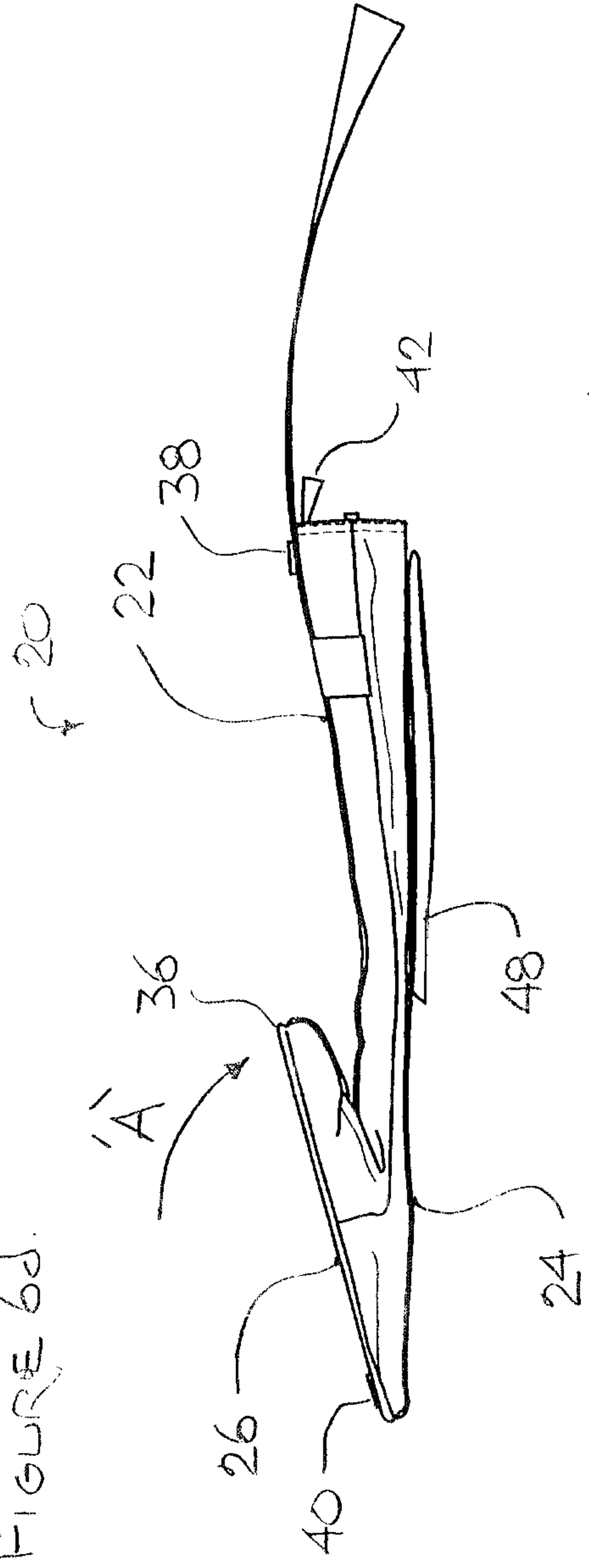

FIGURE 6c

20~

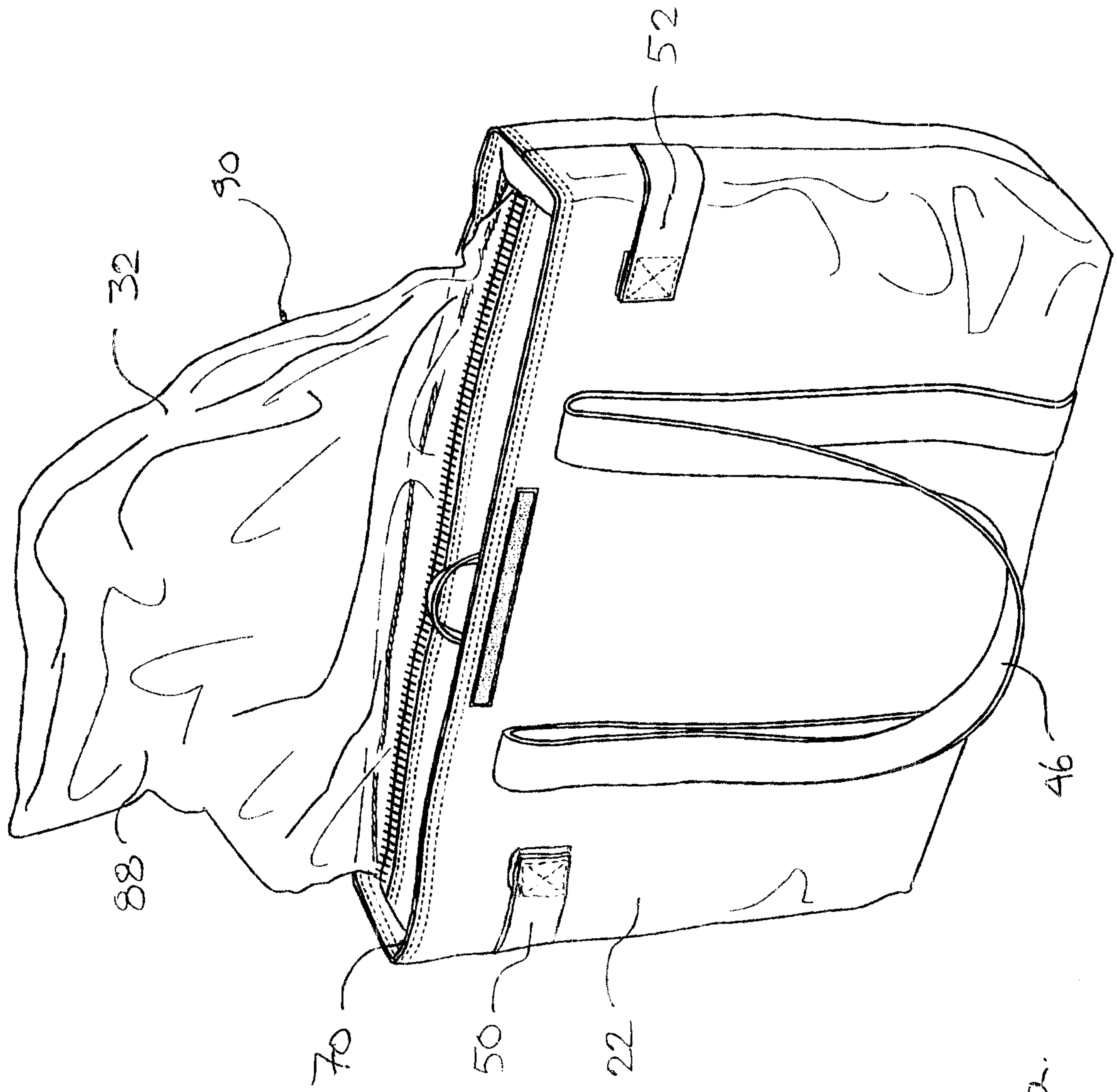

FIGURE 7a.

20 ~

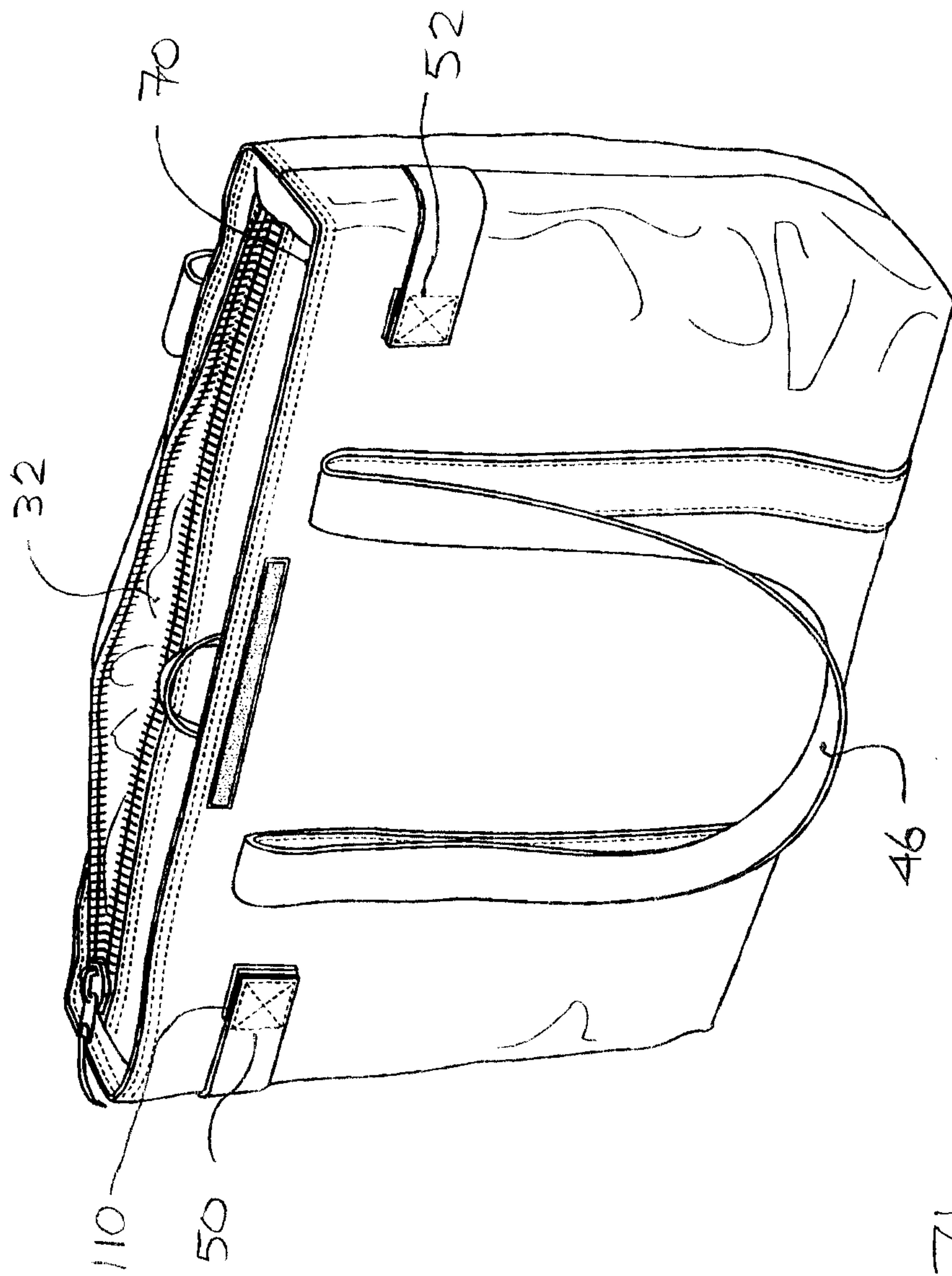

FIGURE 7b.

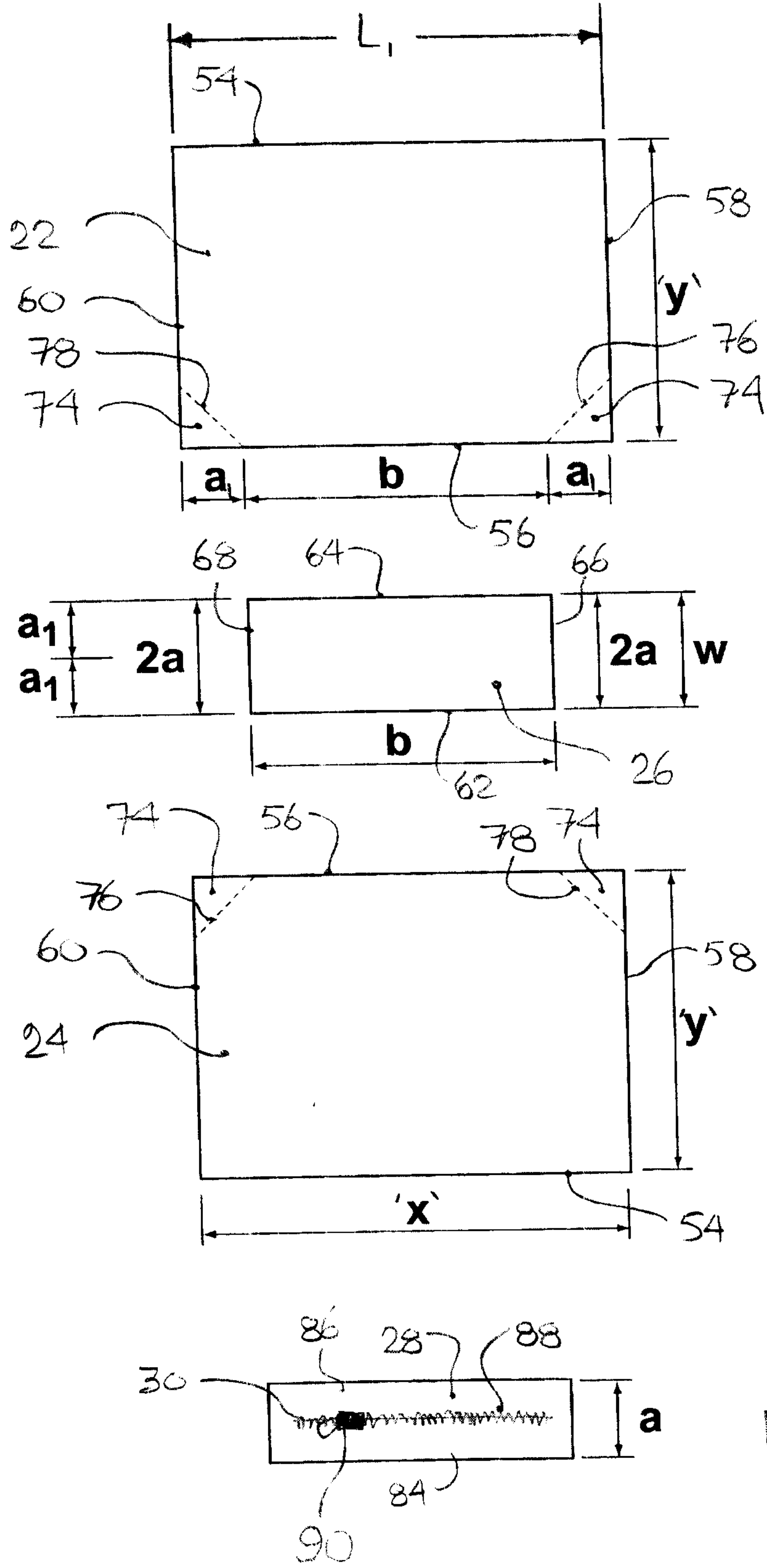

FIGURE 8

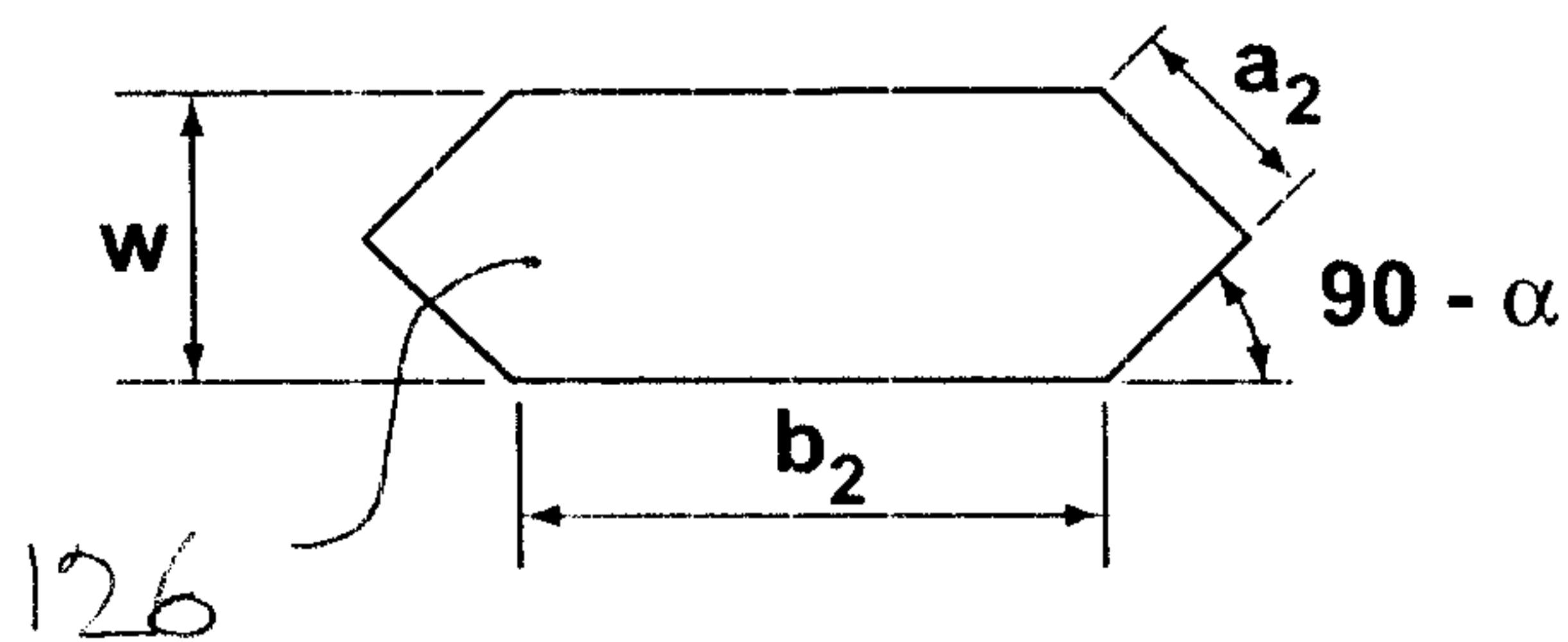
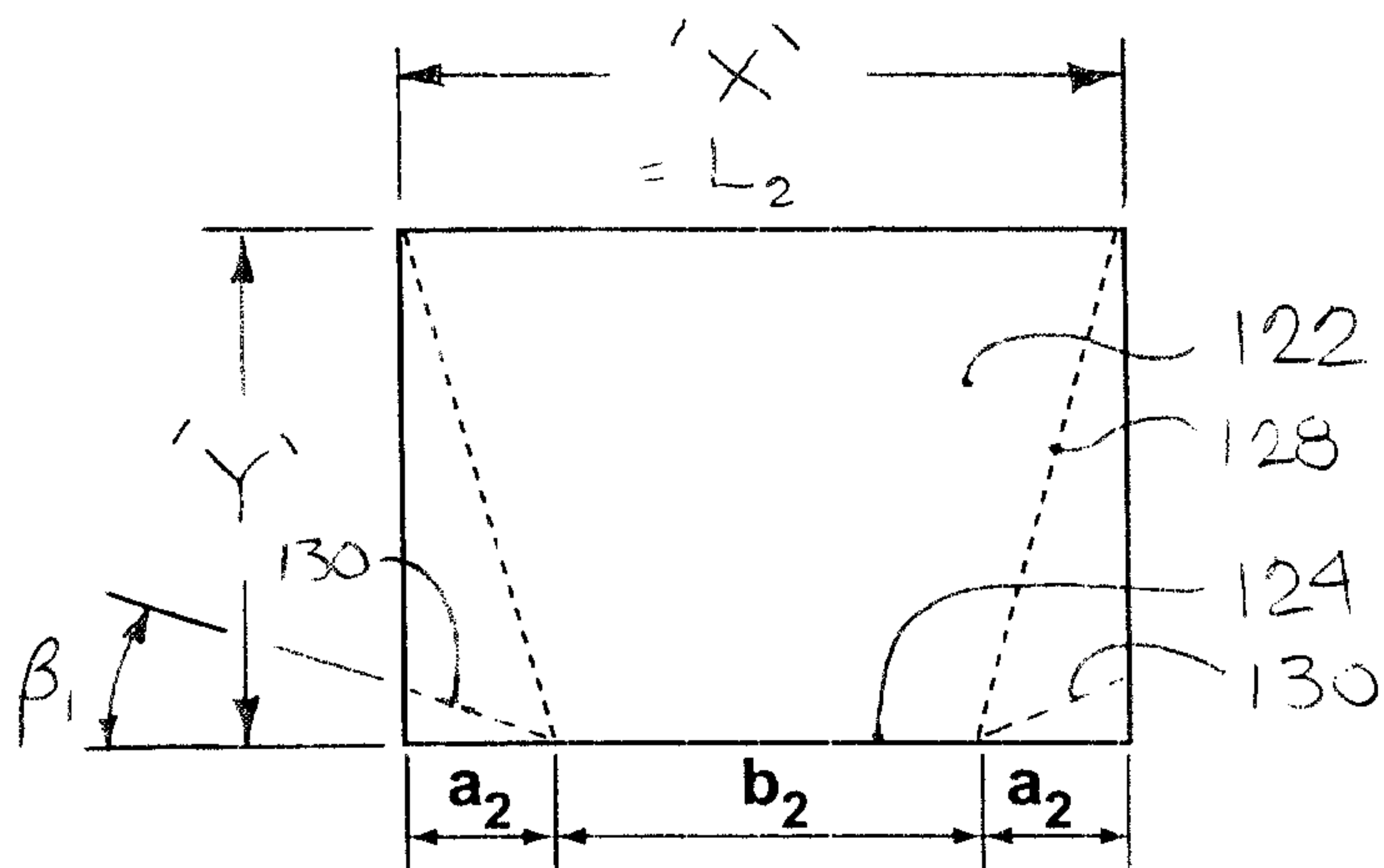

FIGURE 9a.

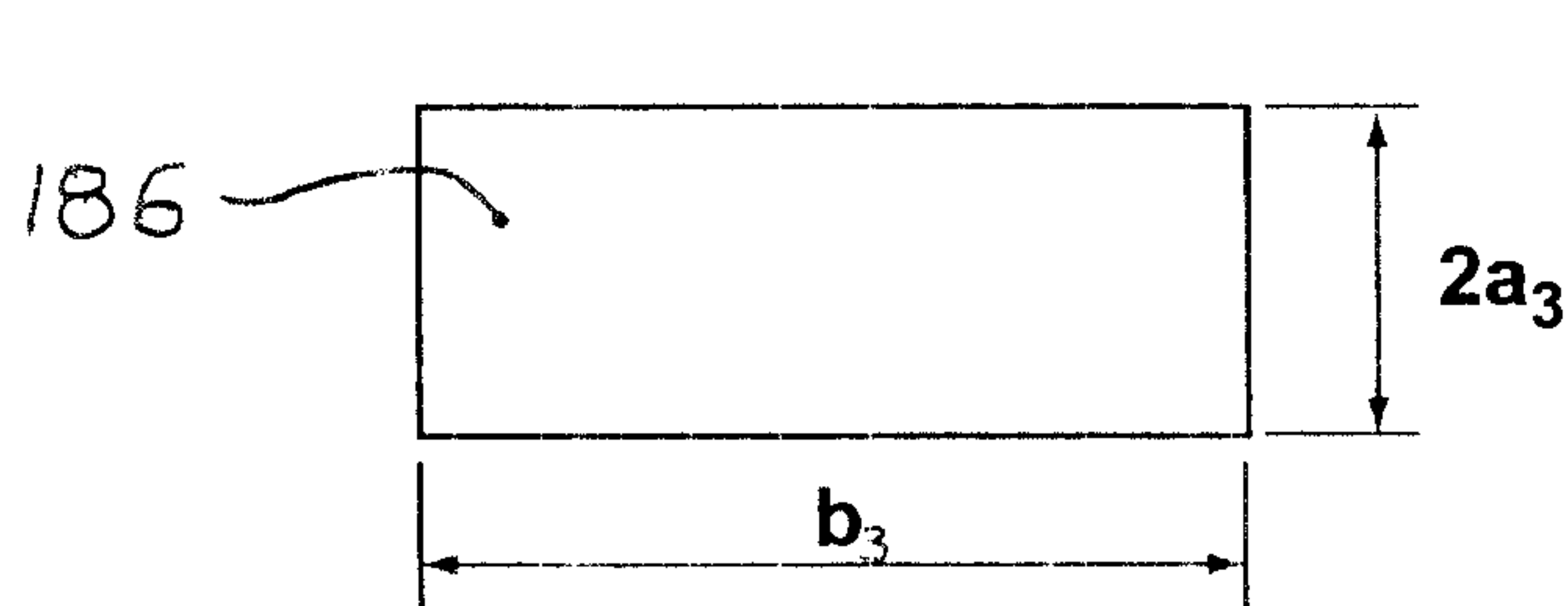
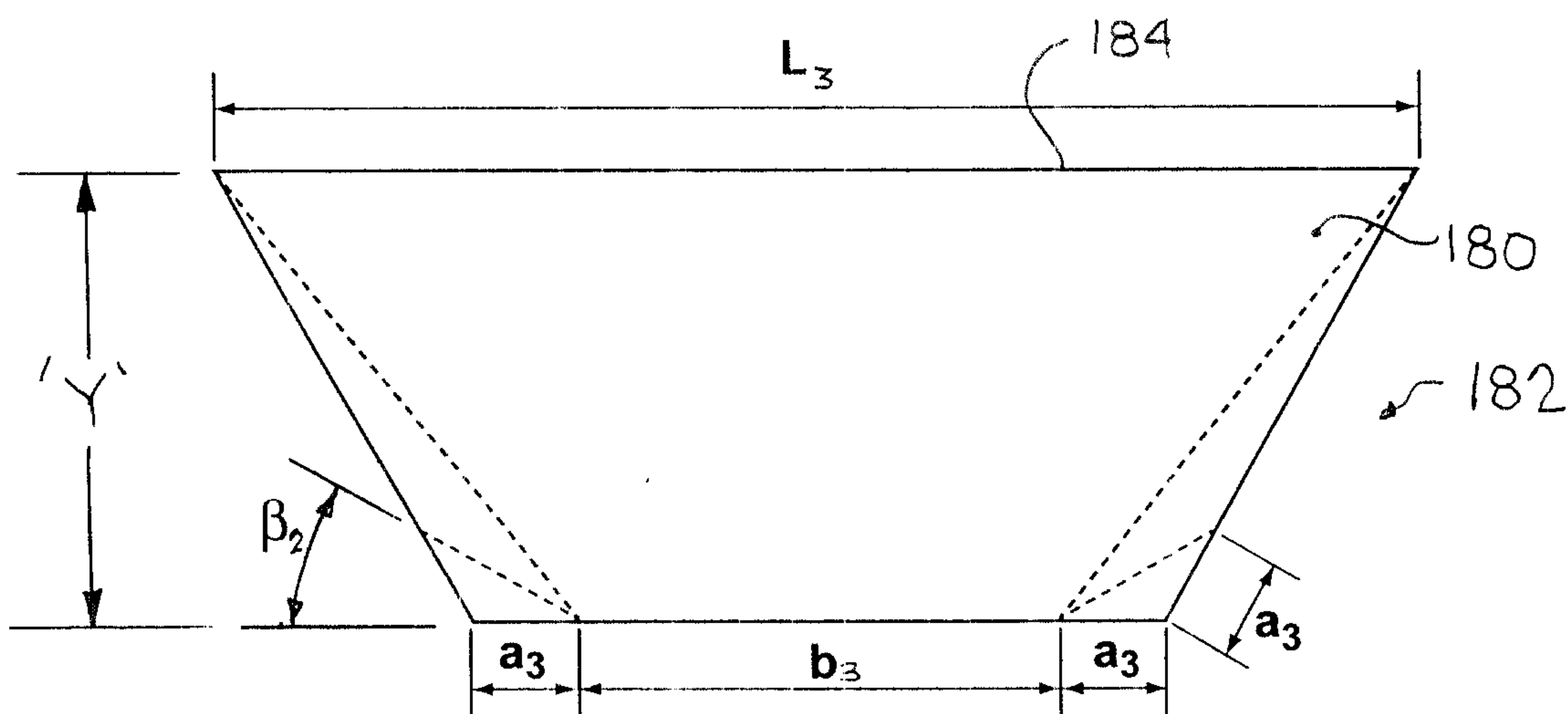

FIGURE 9b.

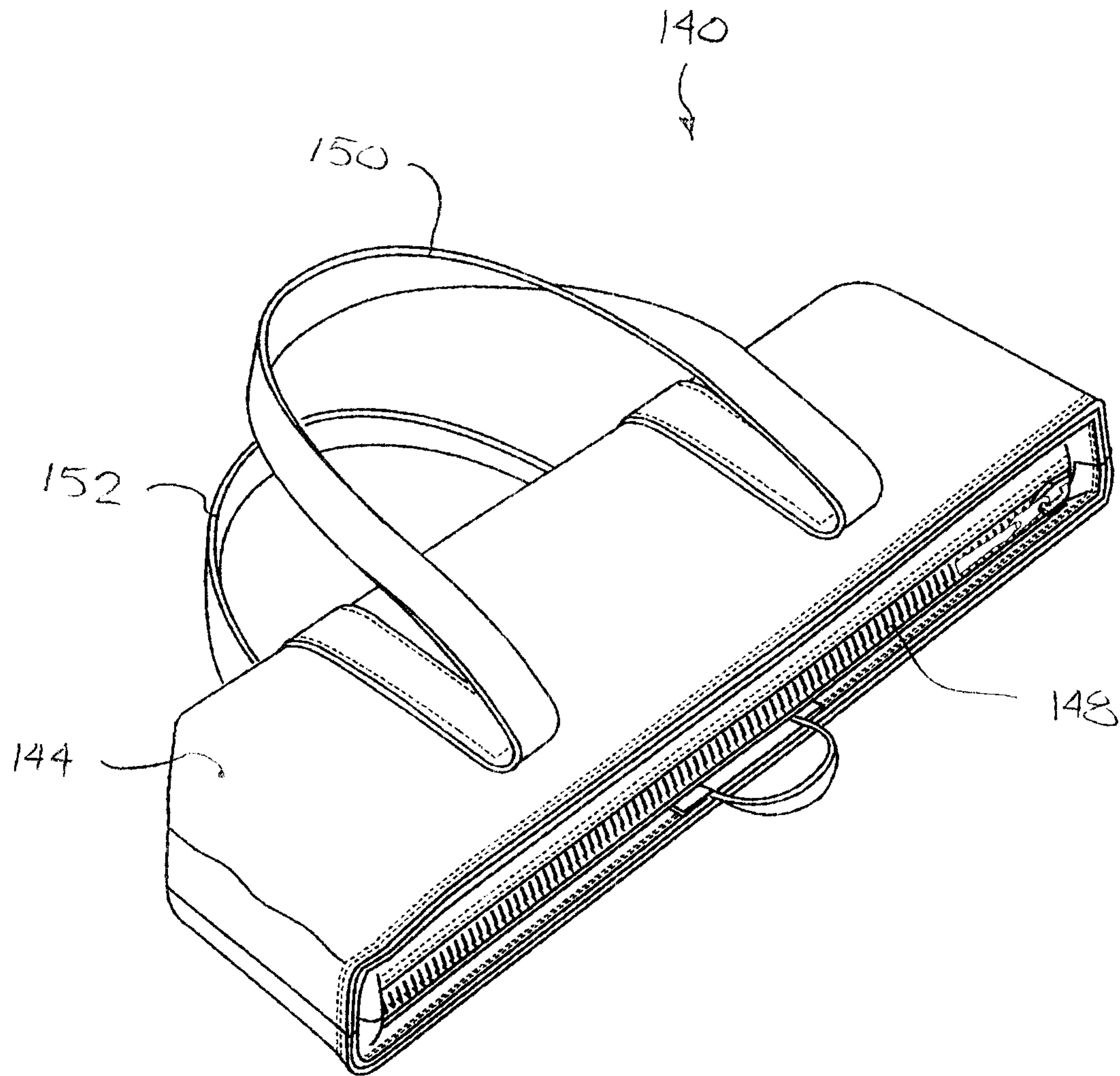

FIGURE 10a.

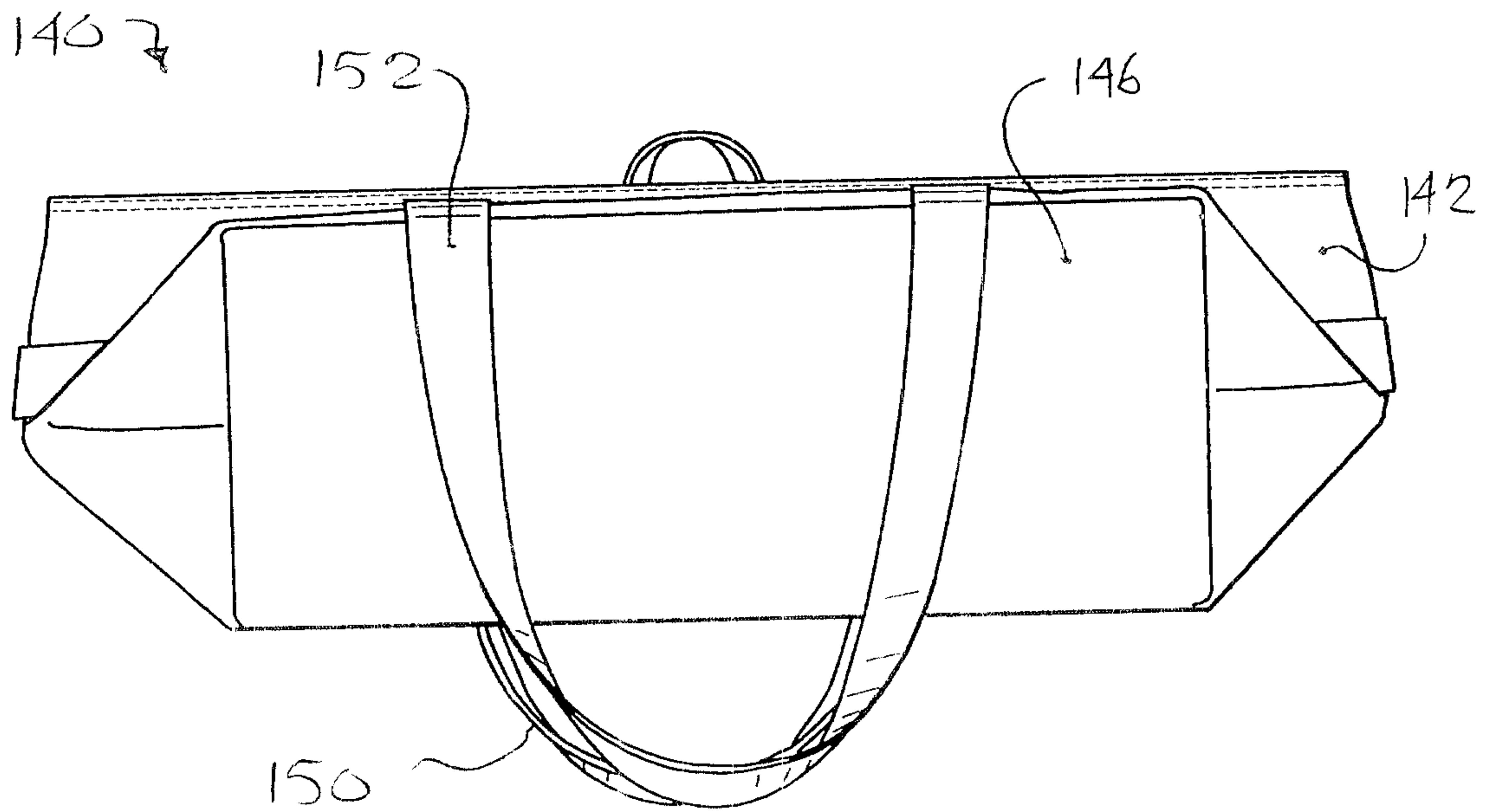

FIGURE 10c

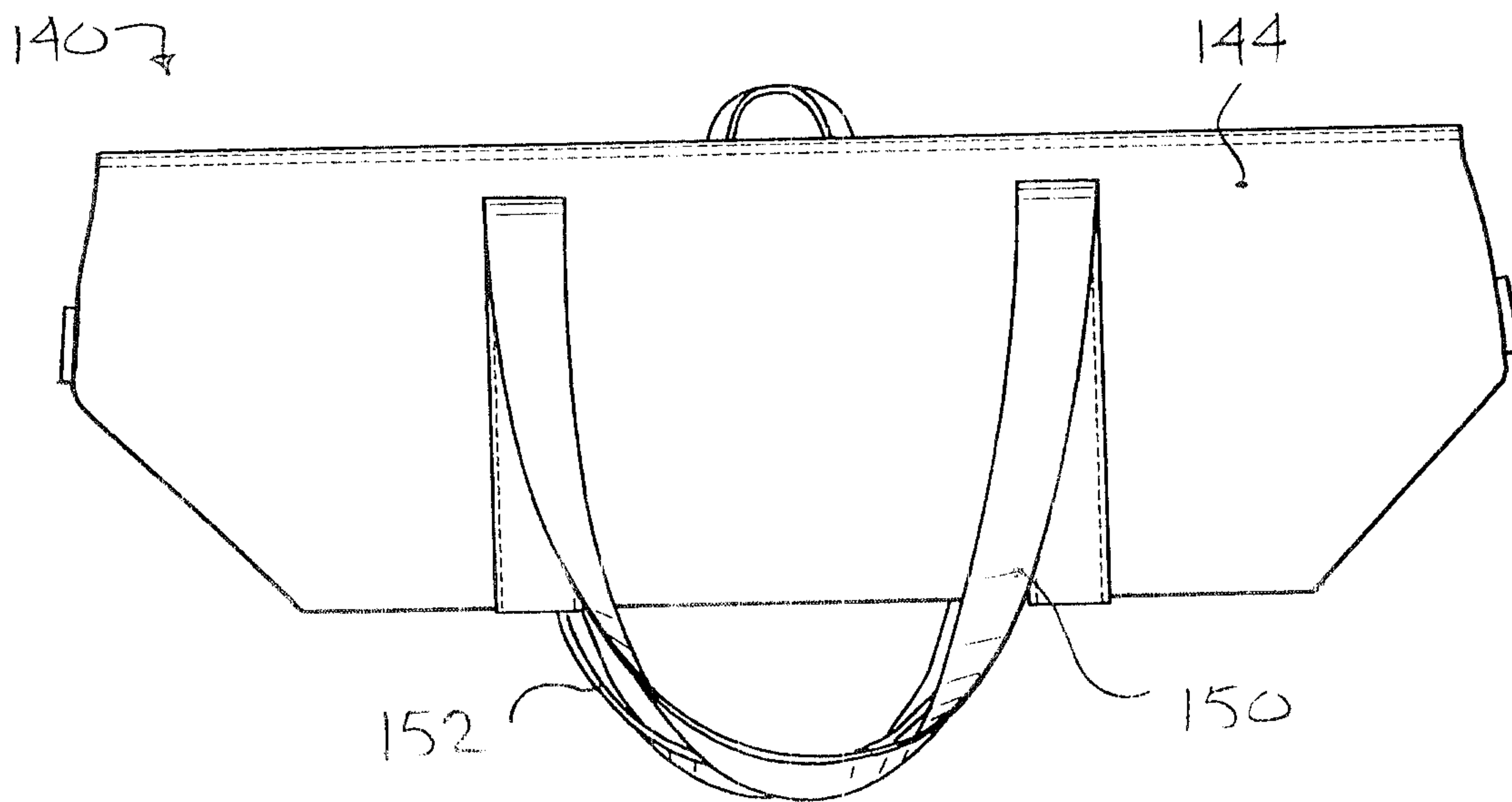

FIGURE 10b.

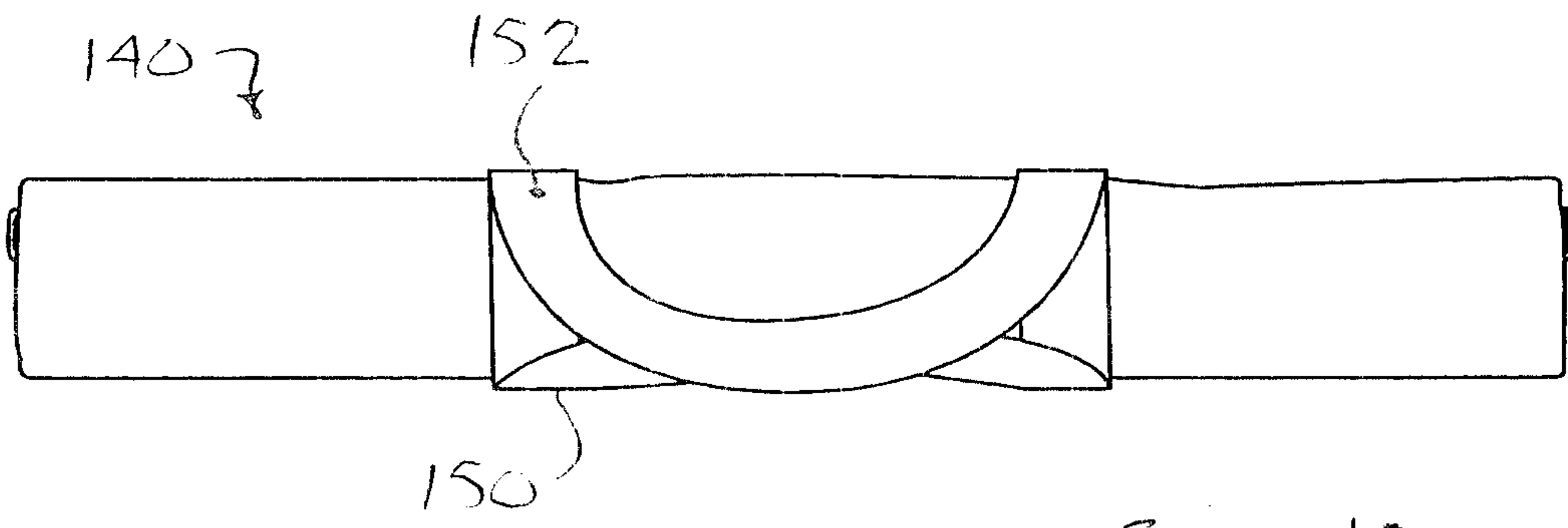

FIGURE 10g.

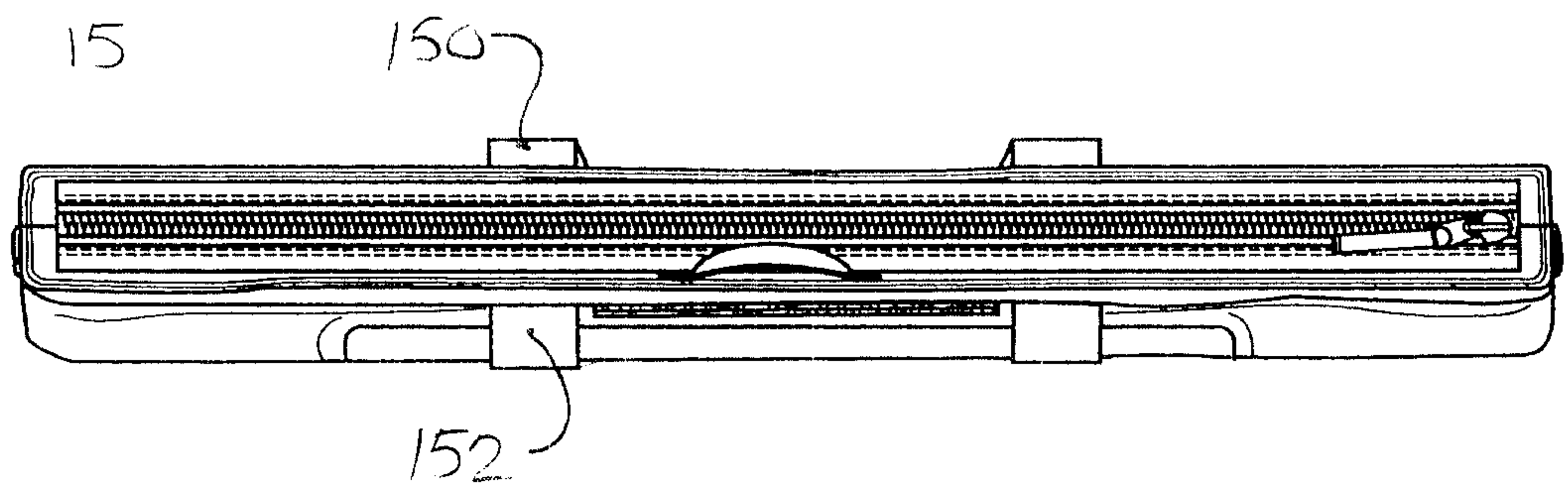

FIGURE 10f.

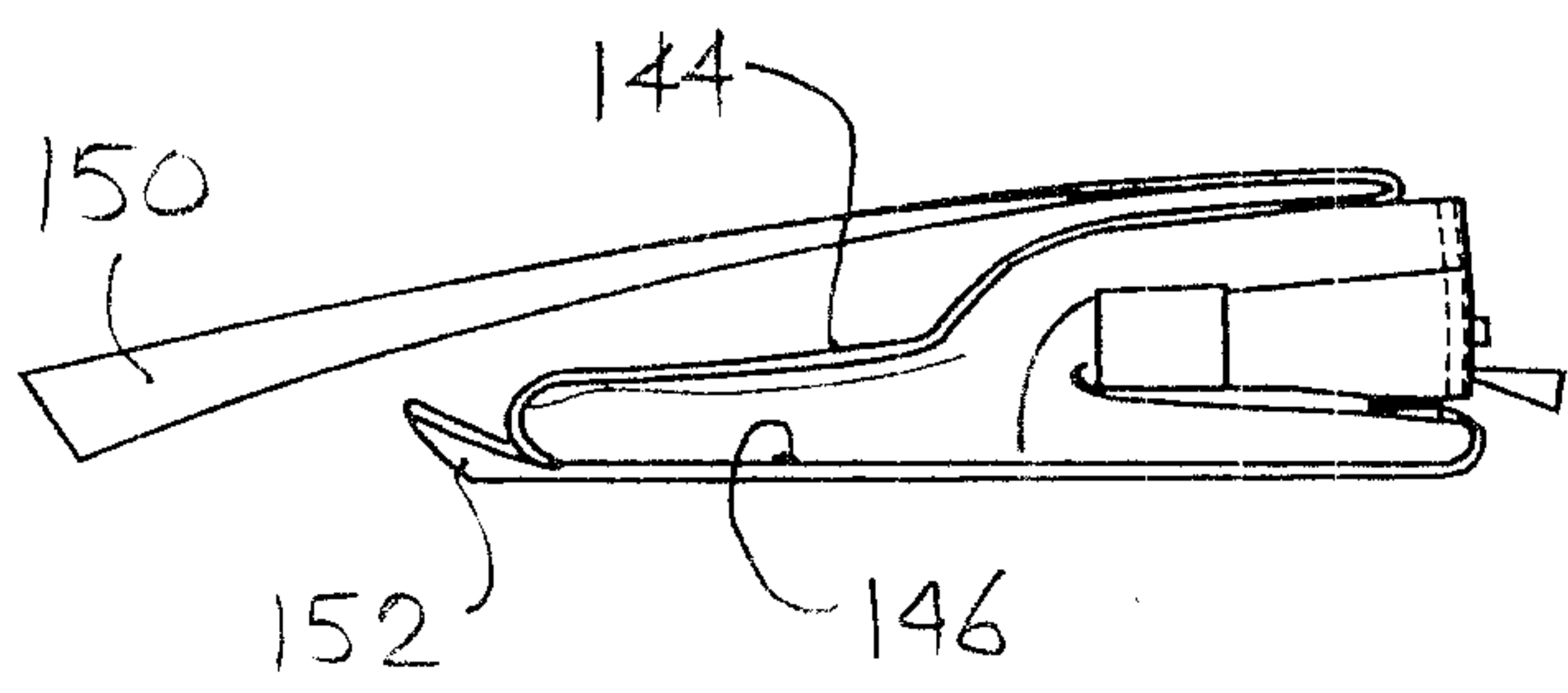
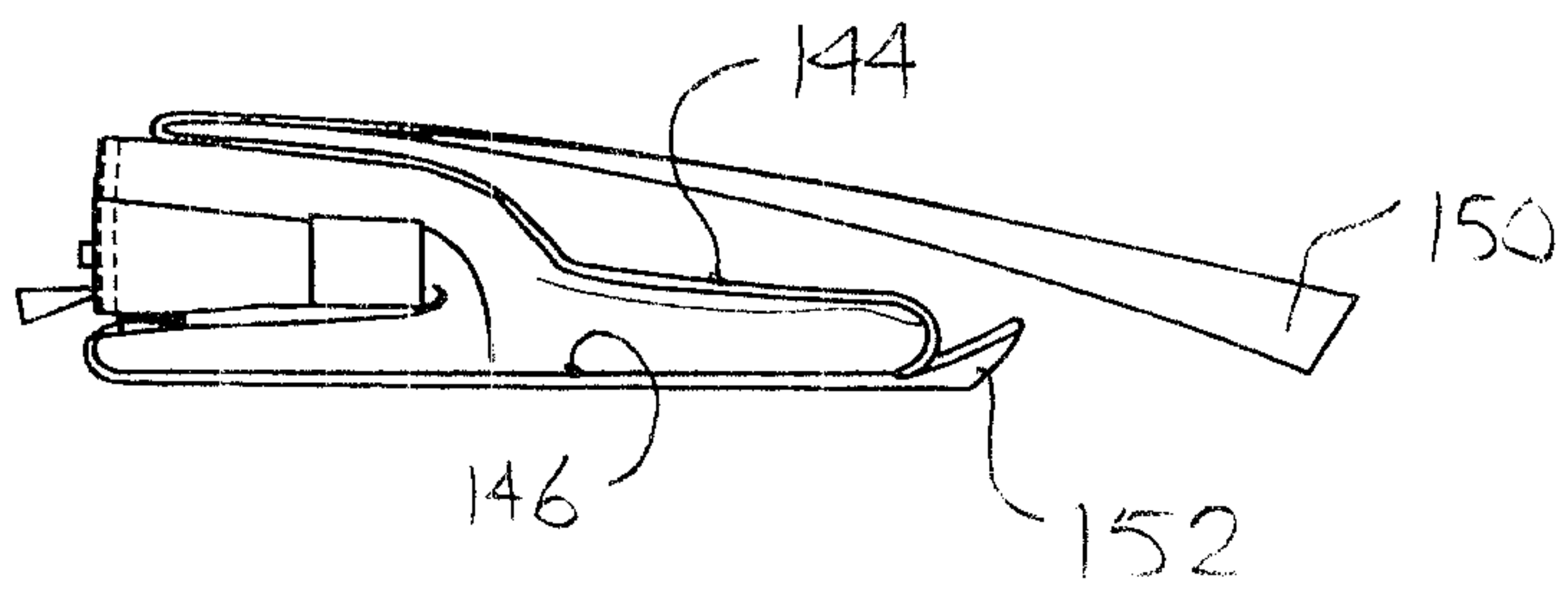

FIGURE 10e.

FIGURE 10d.



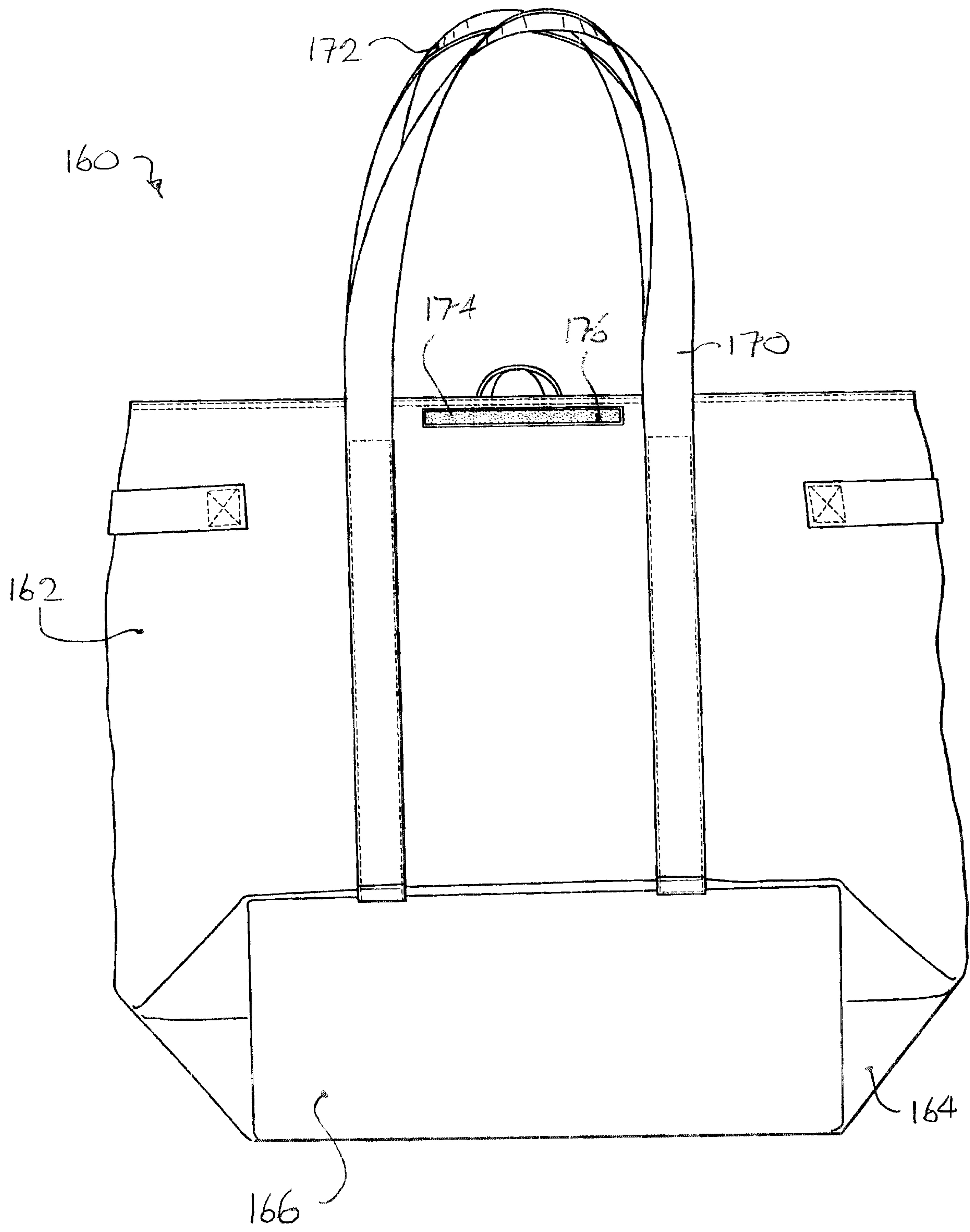
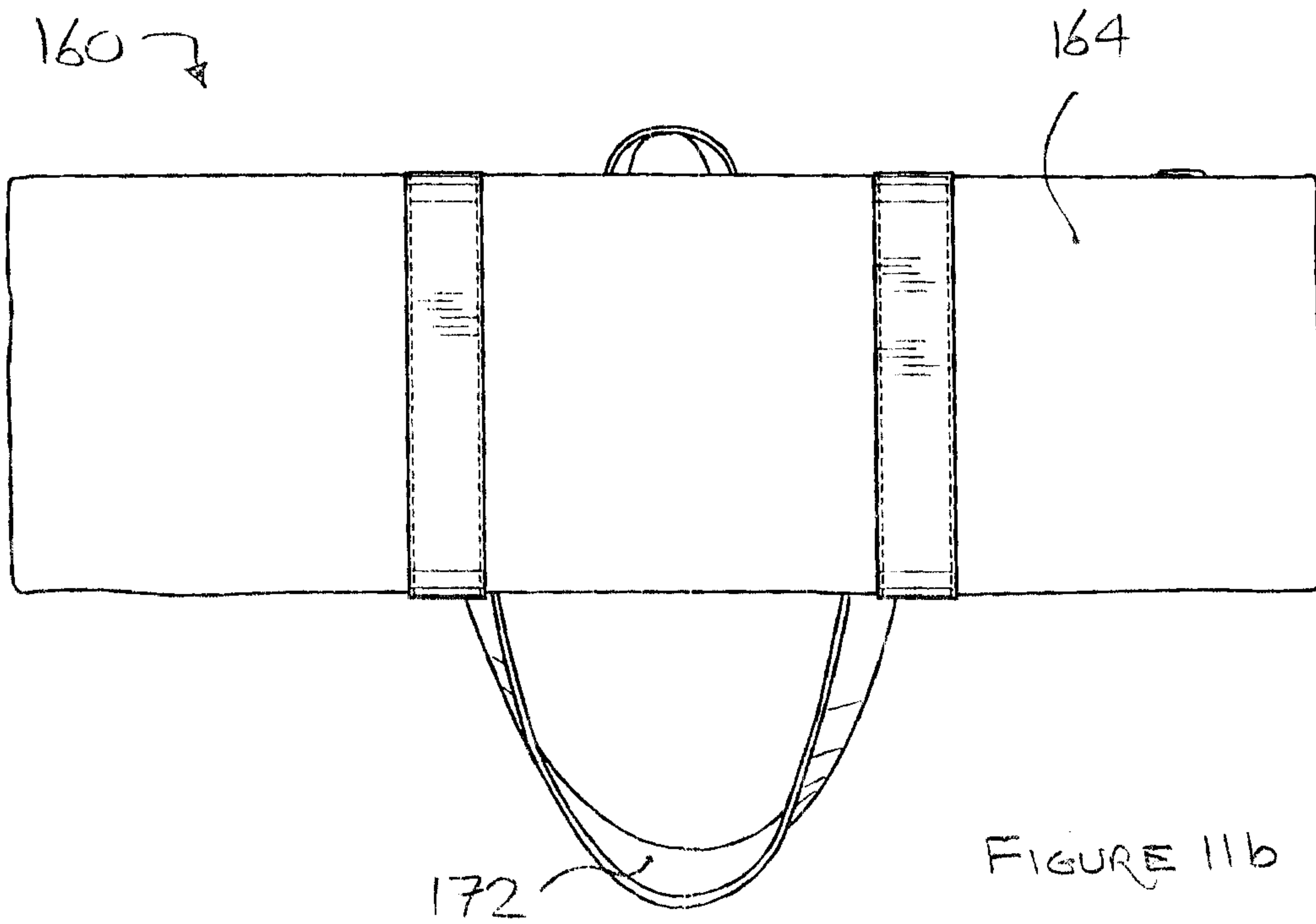
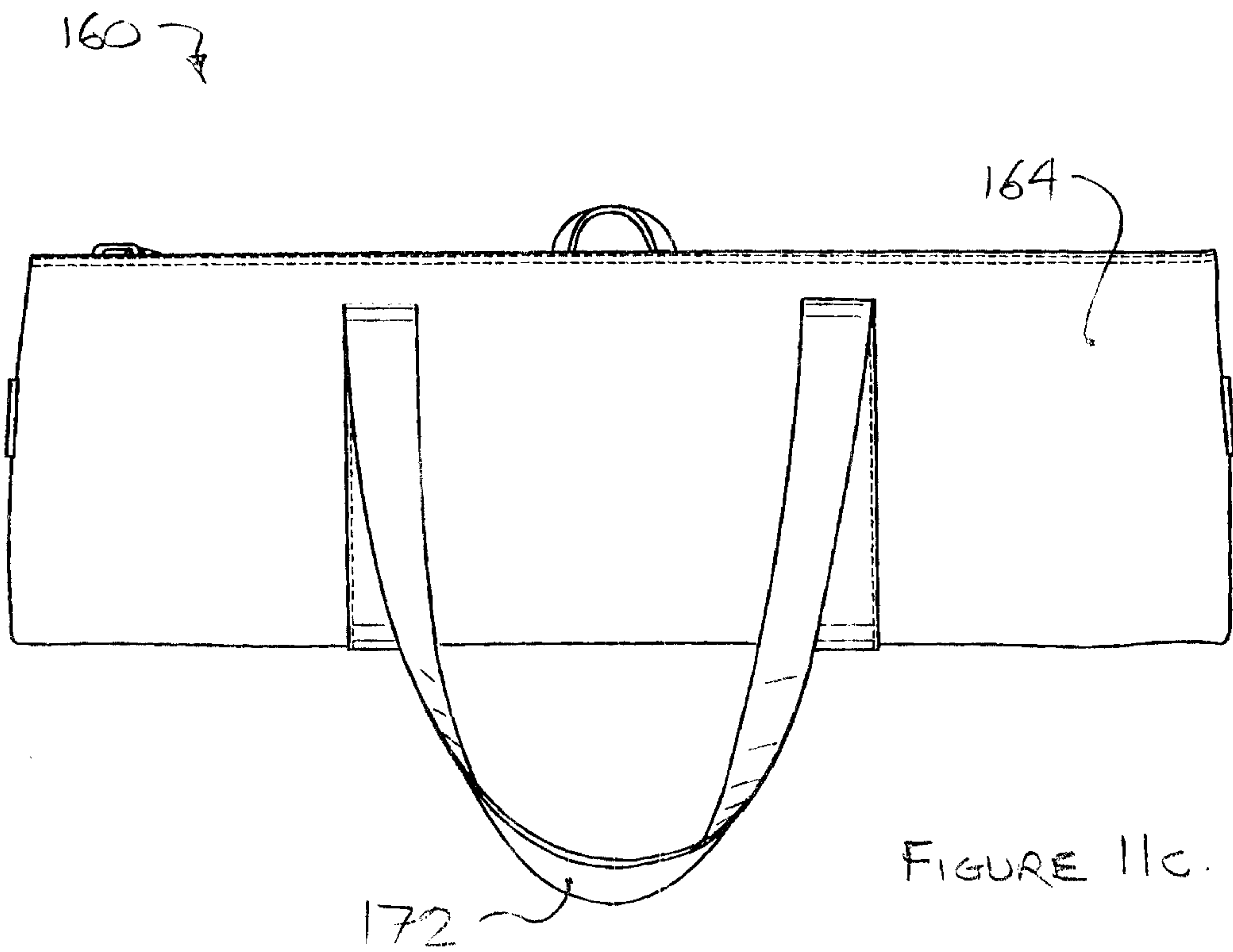

FIGURE 11a.



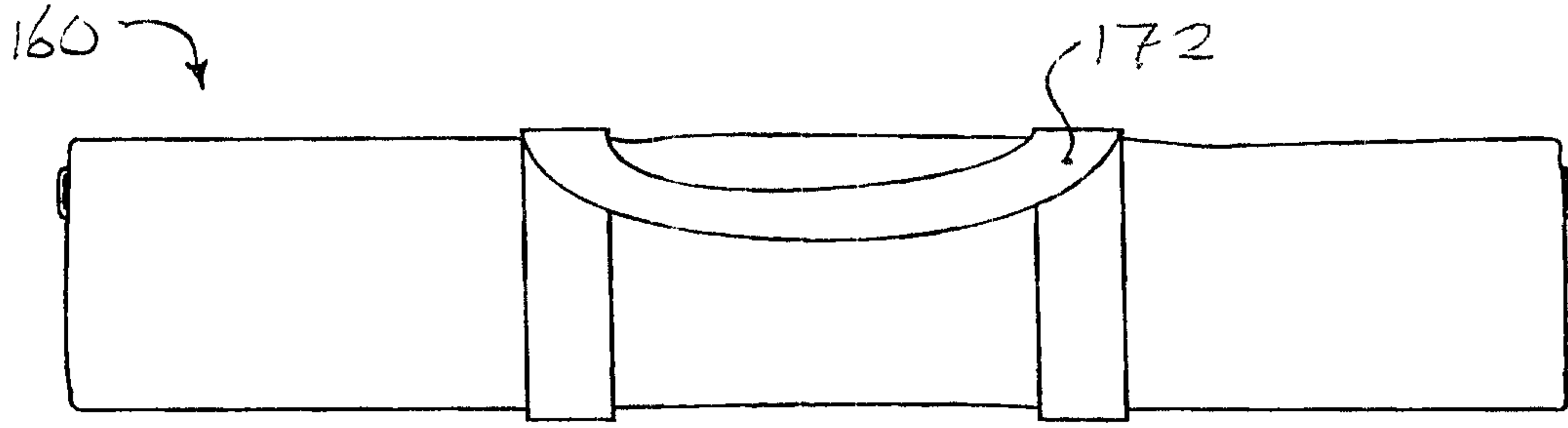

FIGURE 11g

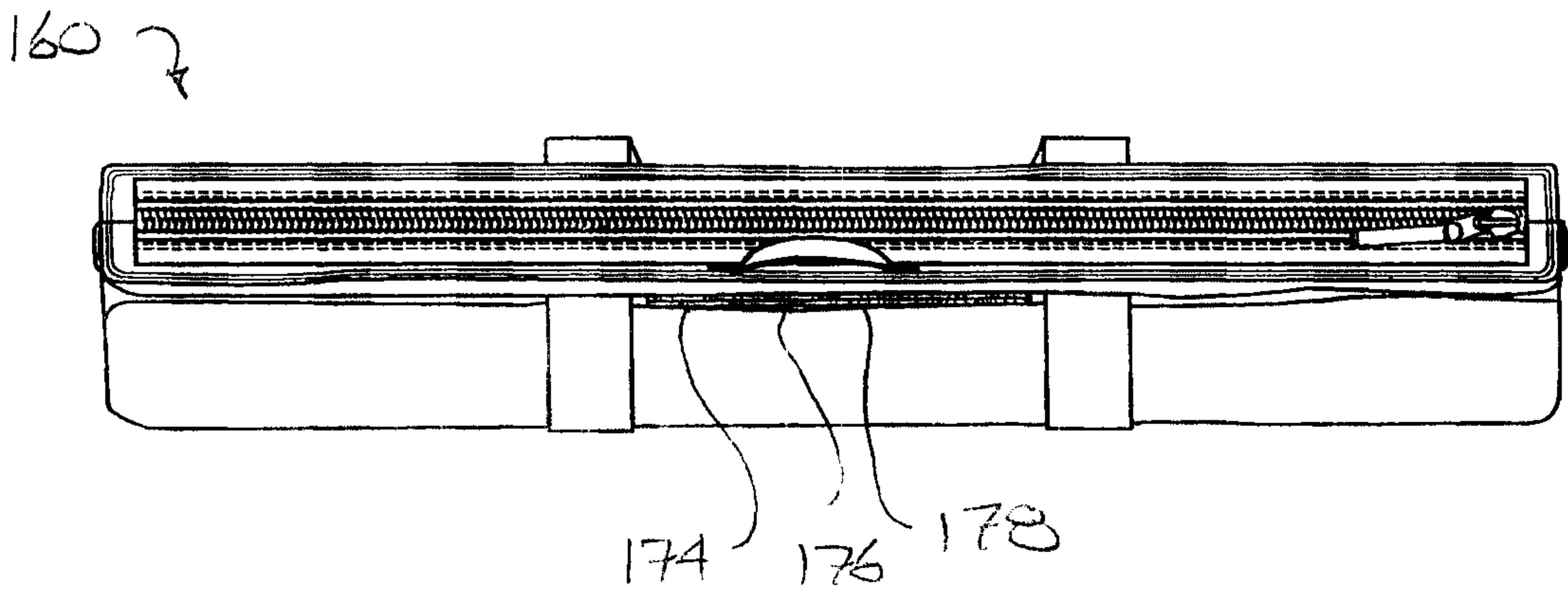

FIGURE 11f

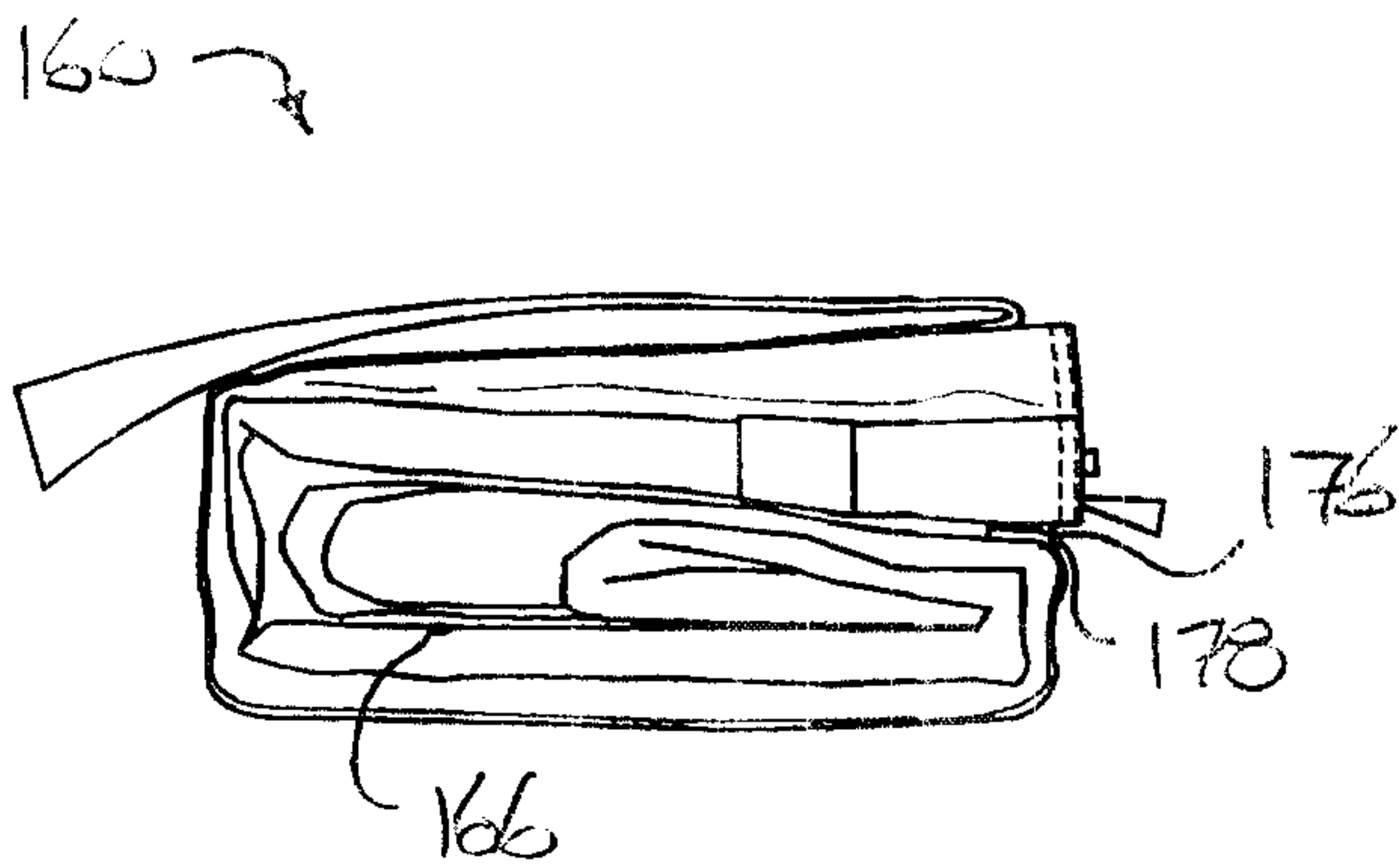

FIGURE 11e.

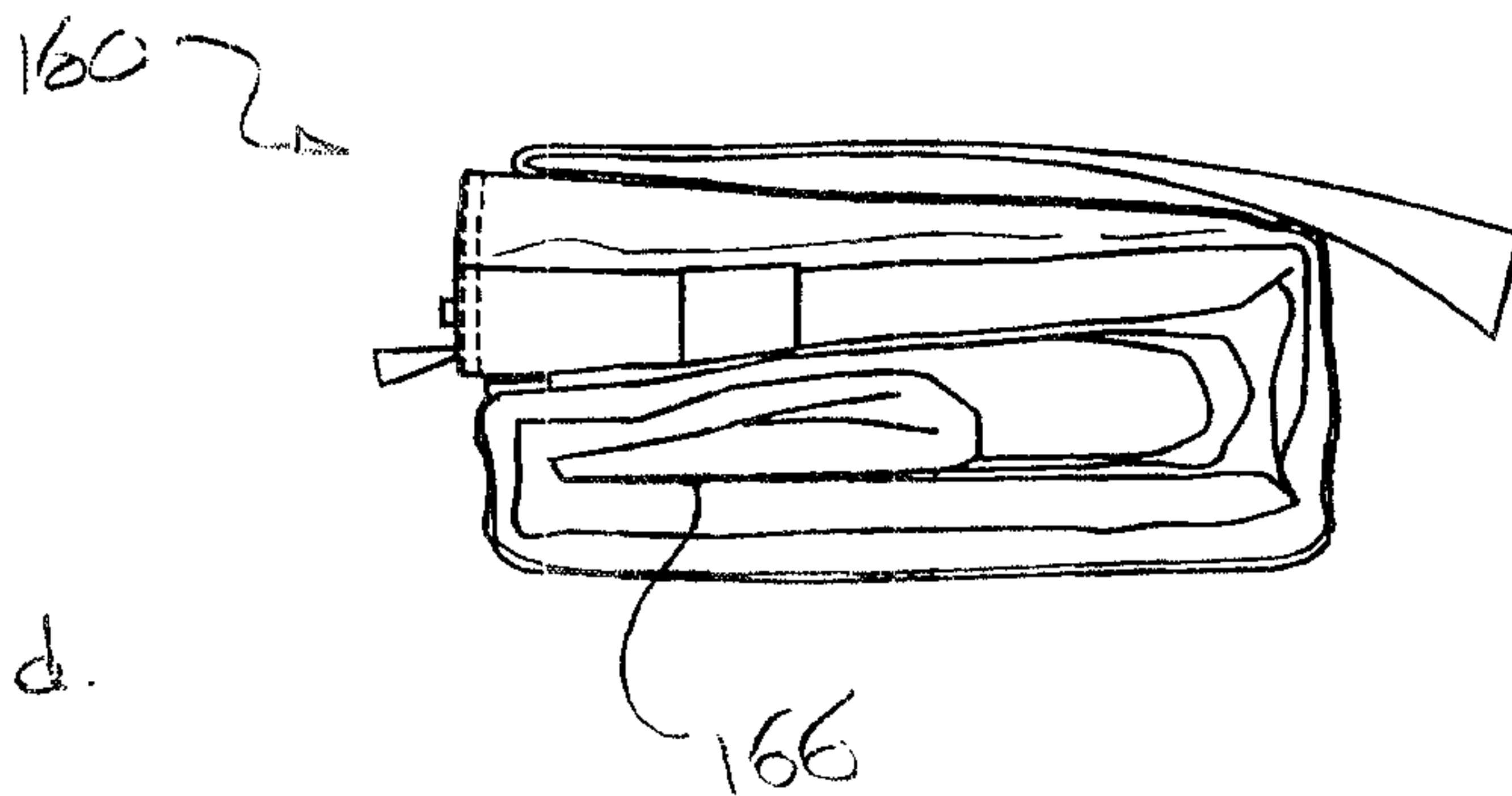

FIGURE 11d.

