

Oct. 17, 1961

C. J. LANGMACK

3,004,635

PORTABLE MAST

Filed June 8, 1954

3 Sheets-Sheet 1

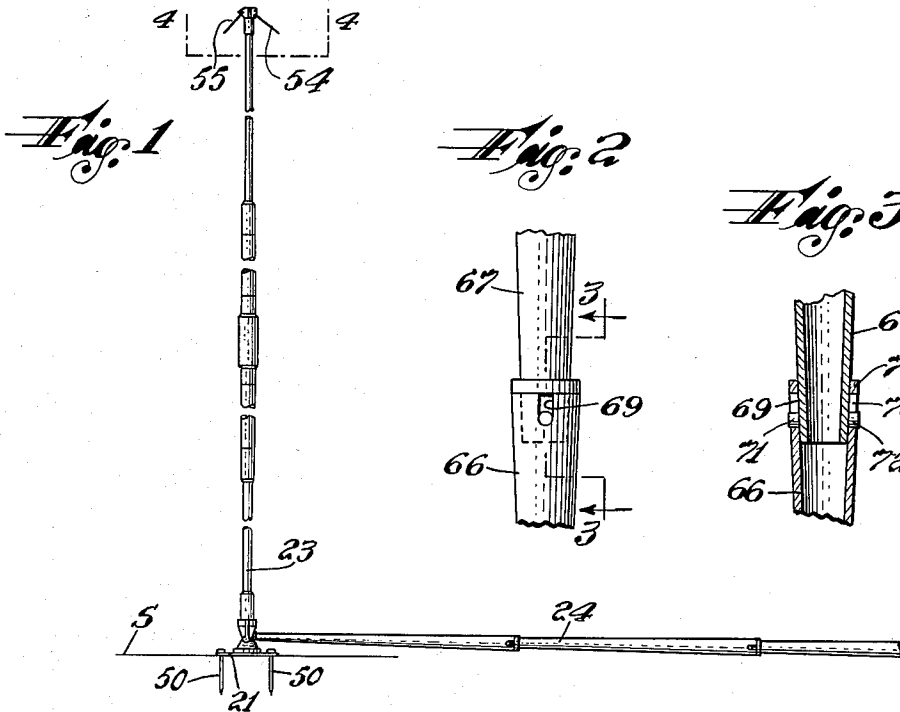

Fig. 1

Fig. 2

Fig. 3

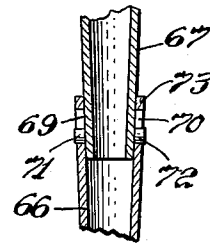
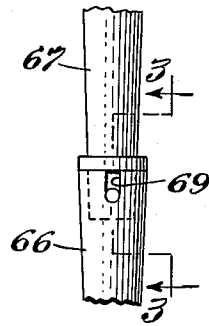
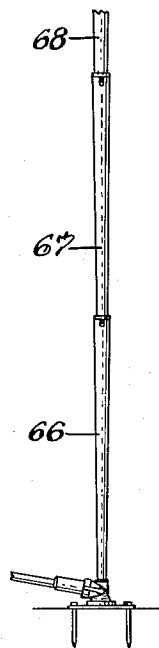
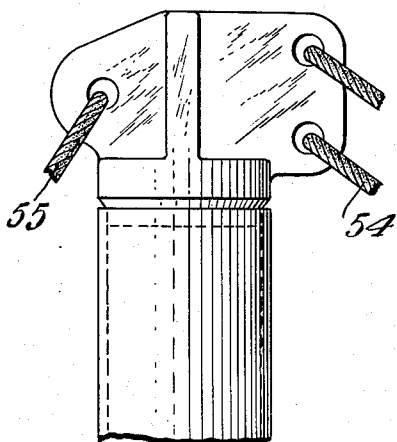

Fig. 4

Fig. 5



INVENTOR.
CARL J. LANGMACK
BY

Harry Foxmeyer
ATTORNEY

Oct. 17, 1961

C. J. LANGMACK

3,004,635

PORTABLE MAST

Filed June 8, 1954

3 Sheets-Sheet 2

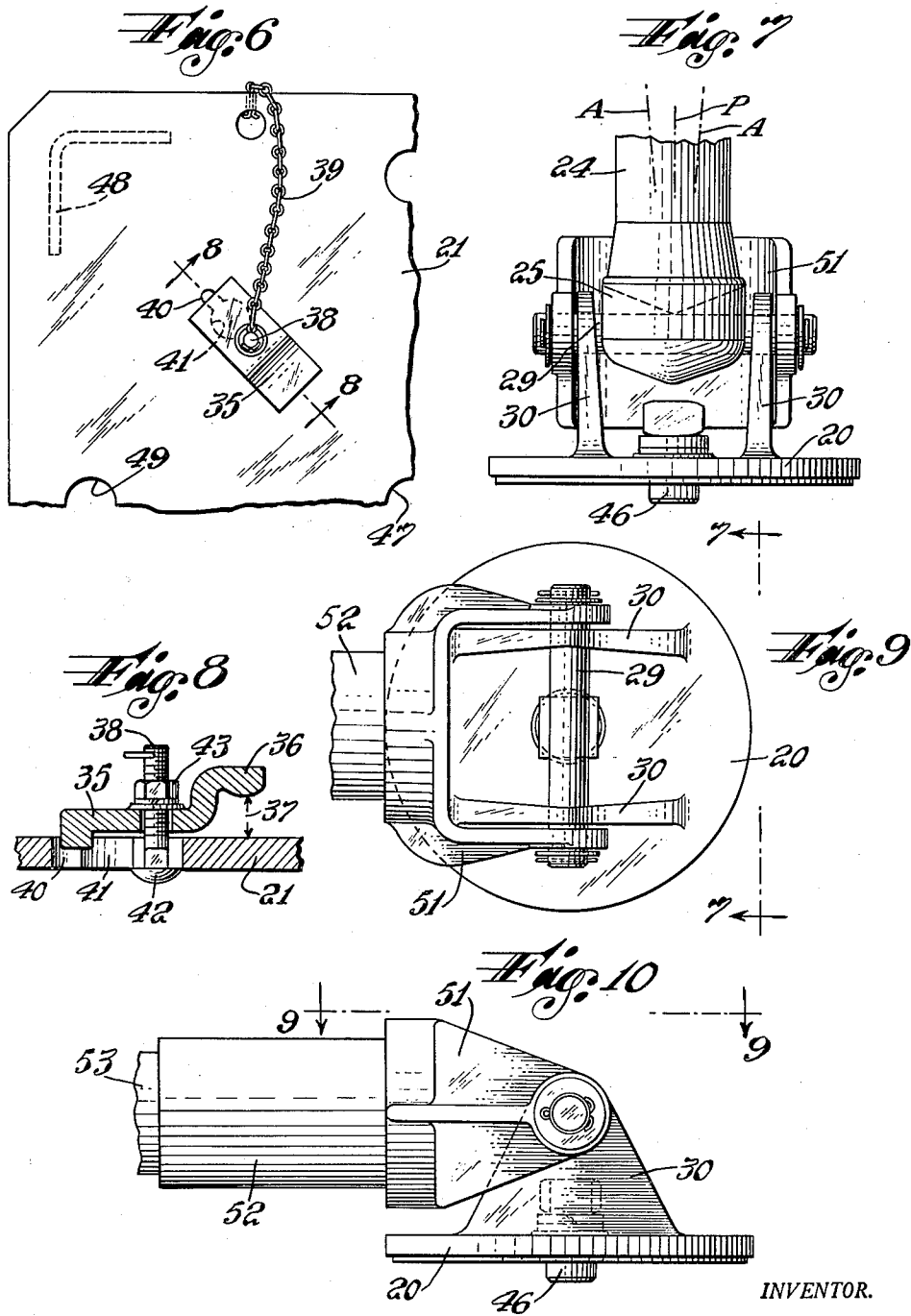

INVENTOR.

BY CARL J. LANGMACK

Harry Brunner
ATTORNEY

Oct. 17, 1961

C. J. LANGMACK

3,004,635

PORTABLE MAST

Filed June 8, 1954

3 Sheets-Sheet 3

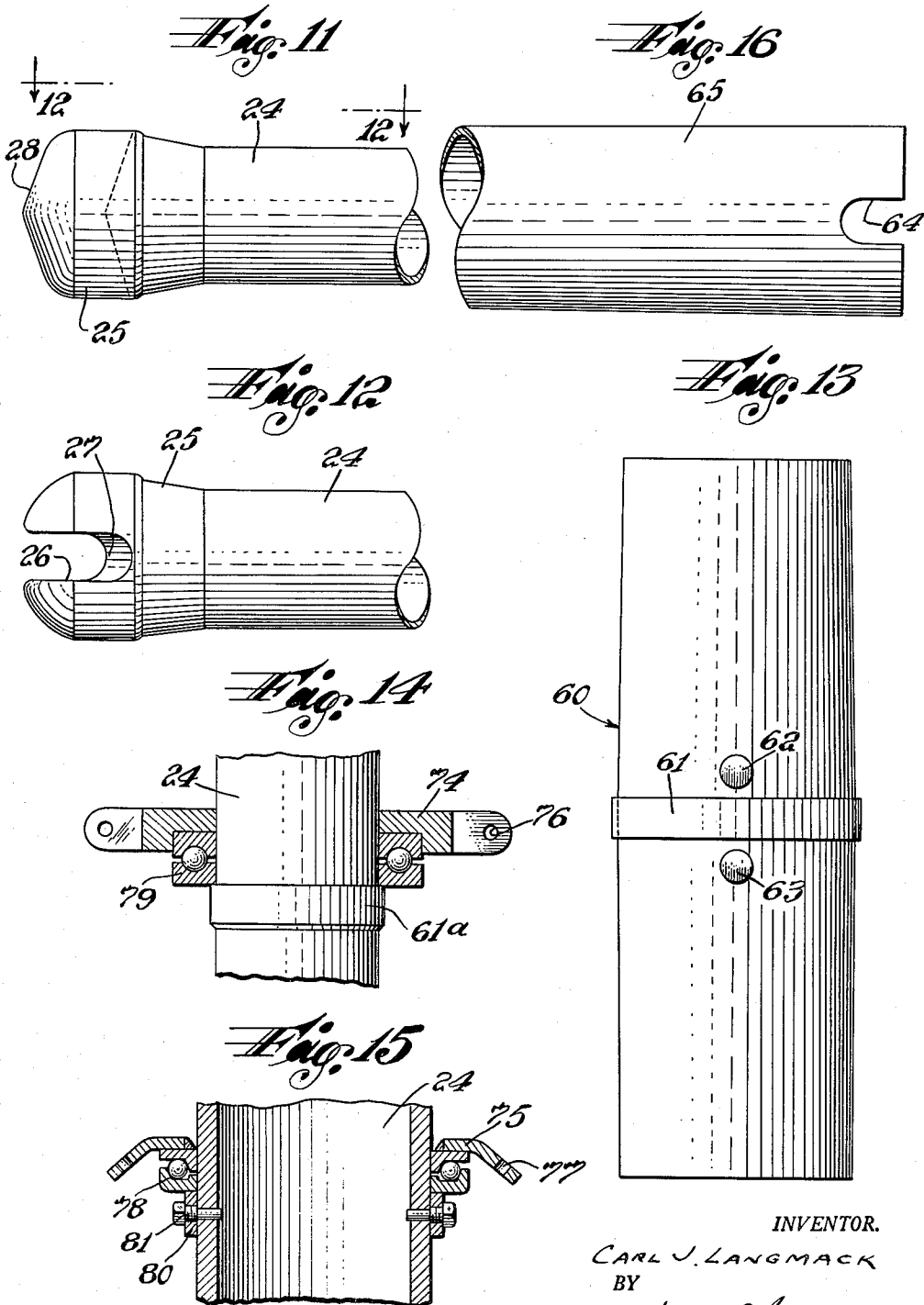

INVENTOR.
CARL J. LANGMACK
BY
Harry Loumes
ATTORNEY

1

3,004,635

PORTABLE MAST

Carl J. Langmack, Plainfield, N.J., assignor to Pfaff and Kendall, Newark, N.J., a corporation of New Jersey
 Filed June 8, 1954, Ser. No. 435,135
 1 Claim. (Cl. 189—26)

This invention relates to a mast useful for public utilities and other purposes. The invention is broadly directed to the provision of a portable mast unit which is so constructed that it may readily be manufactured and stored in a minimum of space, for assembling on the spot, in a rapid manner and without the use of special tools. Its structural features are such that it may be rotated on its own axis, pivotally moved relative to a perpendicular line, and swung in circles, thus enabling a very maximum of positive adjustments to be made at the time of and after installation. Masts made in accordance with the present invention may be erected with an expenditure of but a fraction of the time and effort formerly required for the purpose.

In the drawings:

FIG. 1 is a fragmentary elevational view showing a portable mast unit of this invention, the boom member having been rotated to a vertical position relative to the supporting surface, while the mast member is disposed on said surface, at the time of initiation of elevation of the mast,

FIG. 2 is a fragmentary elevational view of a pair of mast sections embodying the invention,

FIG. 3 is a vertical sectional view thereof, taken on line 3—3 of FIG. 2,

FIG. 4 is an enlarged fragmentary elevational view of the upper end of the boom member shown in FIG. 1,

FIG. 5 is a fragmentary elevational view of boom and mast members embodying the invention, with the mast member shown rotated to the perpendicular position relative to the supporting surface,

FIG. 6 is a quadrant plan view of a base plate adapted for use in carrying out the invention,

FIG. 7 is a fragmentary elevational view taken on line 7—7 of FIG. 9, showing the bearing plate and the mast, the boom mounted thereon being shown fragmentarily,

FIG. 8 is an enlarged sectional view taken on line 8—8 of FIG. 6, showing a form of marginal guide member adapted to be readily secured to the base plate for guiding the marginal edges of the bearing plate,

FIG. 9 is a fragmentary plan view taken on line 9—9 of FIG. 10,

FIG. 10 is a fragmentary elevational view of the bearing plate with the boom post member secured thereto,

FIG. 11 is a fragmentary elevational view of a mast member, embodying the invention,

FIG. 12 is a fragmentary elevational view thereof, taken on line 12—12 of FIG. 11,

FIGS. 13 and 16 are views of a member which may be used as a center section of the mast, and

FIGS. 14 and 15 are detailed sectional views of a means which may be used for securing guying cables to the mast adjacent the top thereof and therealong.

As shown in the drawings, the device of this invention comprises essentially a bearing plate 20, to be secured to supporting surface S (FIG. 1) on which the mast is to be erected, by suitable means, such as, for example, by positioning the bearing plate 20 on a base plate 21. The bearing plate 20 has pivotally mounted thereon the boom post 52 to which the lower end 53 of the main section of a boom 23 may be secured by force-fitting, welding, etc. The mast 24 is pivotally disposed on the bearing plate 20 as by providing the lower end of the mast with the head 25 (FIGS. 11 and 12), having a

2

slot 26, the upper end wall 27 of said slot being inwardly and outwardly extended from the center thereof to facilitate rocking the mast on pin 29 which is freely received in said slot. The lower end 28 of the mast 24 is preferably tapered to correspond with the upper wall of the slot, for the same purpose. Pin 29 is secured to spaced bearings 30 on the bearing plate 20 (FIG. 7). By this construction mast 24 may be rocked on the pin 29 from a perpendicular position P shown on FIG. 7 to angular planes thereto as indicated, by the lines A. Thus, the mast 24 may be rocked on the bearing plate 20 so as to compensate initially or after installation for any deviation in the bearing plate from a true horizontal position, such as might occur where the surface S shifts or is not truly horizontal. The bearing plate 20 is preferably rotatable on the base plate 21; the bearing plate 20 may be made circular as shown in FIG. 9 and the base plate 21 may have means for guiding the marginal edges of said bearing plate during rotation thereof. Such means may be of any convenient form, such as shown by way of example in FIGS. 6 and 8, wherein flanged brackets 35 are shown, each having a free end 36 offset upwardly so that when the bracket is clamped to the base plate 21 said free end will define, with the base plate, an opening 37 in which the bearing plate 20 may rotate. There may be four or more of such brackets disposed on the base plate, the representation in FIG. 6 being for the purpose of illustration only. Said brackets may be secured to the base plate by any suitable means, as for example by providing the brackets with bolts 38 (which might be connected by chains 39 or the like to the base plate 21 so as to preclude accidental separation therefrom preliminary to the assembly of the device). The base plate may be provided with apertures 40 having enlarged portions 41 to first freely receive the heads 42 of the bolts 38 and with constricted portions into which the shanks of said bolts may be moved (with the heads contacting the adjacent bottom surfaces of the base plate 21) to preclude accidental separation of the bolts 38 from the base plates in the initial assembly of the parts; they may be tightened by nut 43 or the like. One end of the bolt 38 may be downturned to dispose the bracket on the base plate in the position shown in FIG. 8. Where, for example, a plurality of brackets 35 are arranged in spaced relation on the base plate, they will serve as a guide to freely receive the bearing plate and permit the latter to rotate on the base plate. To facilitate the rotational location of the bearing plate on the base plate, said bearing plate may be provided with a stud 46 which may be secured thereto centrally for disposition in centrally located aperture 47 (FIG. 6) in the base plate. The latter may be provided with means for securing the same to the surface S; for example angle spacer bars 48 may be welded or otherwise secured to the underside of the base plate, and spikes or anchors 50 may be passed through apertures 49 in the base plate, into the surface S as shown in FIG. 1.

It will be appreciated that when the mast 24 is positioned on the pin 29 of the bearing plate 20, said mast may be rotated on its own axis by rotating the bearing plate 20 on the base plate 21, and may also be rocked as indicated by the lines A—A in FIG. 7, and may be rotated in arcs concentric with its rocked positions, so that an infinite variety of adjustments may be made of the disposition of the mast relative to the surface S.

The boom 23, as above noted, is pivotally mounted on the bearing plate 20, by any suitable means, such as for example, by a yoke member 51 which may be rotatably secured to the pin 29 or pivotally mounted thereon, said yoke member having a stud 52 extending therefrom to which the lower end 53 of the boom may be connected. The yoke 51 and appended stud 52 if desired may be

initially assembled as a unit with the bearing plate 20, moved to a desired location, the base plate 21 secured to the surface S and then the bearing plate 20 positioned on the base plate in a short time. Thereupon the lower end 53 of the boom may be connected to the stud 52 of the bearing plate 20 and the lower end of the mast positioned on the pin 29 and then the mast connected to the boom, as for example, by cables or guy wires 54. Then the boom may be rotated as for example by means of guy wires or cables 55 connected to said boom (FIG. 1) whereupon the mast will be elevated to the desired position. The boom may then be disconnected from the stud 52. A single boom may be thus used with convenience for the rapid positioning of a series of masts pursuant to this invention.

The adjustable features above mentioned in connection with the mast not only permit its initial position in the desired predetermined position but also permit a rapid adjustment to be made from time to time to return the mast to such position.

The mast proper is preferably made of separable sections, as for example by forming the central section 60 (FIG. 13) of the mast in the form of oppositely tapered tube sections, with a stop ring 61 welded or otherwise secured medially of said central section 60. The latter is also provided with pins 62, 63 therethrough for reception in slots such as shown as 64 in the sections such as 65 to be connected with the central section 60. As shown in FIGS. 2 and 3, the mast may be formed of sections of individually tapered tubes such as 66, 67, 68 (FIG. 5) so proportioned as to nest one within another (or alternate sections nesting within alternate sections) to reduce storage space and shipping costs. Such tubes (for example, illustrated in the case of the tube 66 in FIG. 2) may have opposed recesses, 69, 70 for reception of opposed pins 71, 72 of the tube section 67 to be connected thereto. Section 67 may be provided with stop means such as a ring 73 welded thereto and adapted to engage the end of the tube 66 as shown in FIG. 3 to thus register the parts. It will be appreciated that a tube whose internal diameter is slightly larger than the external diameter of the upper end of the tube 66 will snugly receive the tube section 67; by thus proportioning the parts properly the entire mast may be packaged in a relatively few sections at the point of manufacture for shipment and assembly at the point of installation and the parts may be assembled and later disassembled, if desired, readily.

The mast 24 may be provided with means such as the rings 74, 75 (FIGS. 14, 15) having openings 76, 77 for reception of guy wires or cables (not shown) secured at

their other ends to suitable anchor elements in the surface S to connect the mast to said surface and adjust the position thereof from time to time. The said rings 74, 75 may be connected to the mast 24 by anti-friction means such as generally shown as 78, 79 in FIGS. 14 and 15. Ring 78 may be positioned on a ring 80 which in turn may be welded or bolted (as at 81) to the mast; the anti-friction means 79 of FIG. 14 may likewise be positioned on a ring such as 61a. Rings 74, 75 may thus be secured along the mast at the appropriate places, as for example adjacent to the upper end of the mast and along the body thereof, providing an effective and rapid means for connecting guy wires and cables to said mast.

15 Having thus described my invention, what I claim as new and desire to secure by Letters Patent is:

A portable unit for elevating a mast to a position perpendicular and plumb to a horizontal supporting surface, comprising a bearing plate adapted to be secured to the supporting surface, bearings on said plate upstanding therefrom in parallel spaced relation, a pin secured to the bearings in parallel spaced relation to the bearing plate, a yoke having a pair of spaced parallel ends proportioned to be positioned over and to straddle the bearings, a boom secured to said yoke, said pin removably and pivotally connecting said ends of the yoke to the bearings, for radial rotation of the yoke in a plane at right angles to the longitudinal axis of the pin, a mast, the lower end of the mast being transversely slotted to receive the pin secured to the bearings, so that, on connecting the mast to the boom and so radially rotating the yoke and thereby the boom secured thereto, the mast will be radially rotated on the pin to thus elevate the mast to a position perpendicular to the supporting surface, the upper wall of the so-slotted lower end of the mast being upwardly and outwardly extended from the center thereof, so that the mast may be rocked on the pin in the axial plane of the pin, into accurate plumb position on the supporting surface.

References Cited in the file of this patent

UNITED STATES PATENTS

1,581,325	Sands	Apr. 20, 1926
1,917,011	Bird	July 4, 1933
2,351,275	McConnel	June 13, 1944
2,369,533	Cohen	Feb. 13, 1945
2,410,246	Scrivener et al.	Oct. 29, 1946
2,412,678	Goldman	Dec. 17, 1946
2,413,658	Scrivener et al.	Dec. 31, 1946
2,642,754	De Conti	June 23, 1953
2,687,863	Vogt et al.	Aug. 31, 1954