



- (51) International Patent Classification:
H04L 29/06 (2006.01) *H04L 29/08* (2006.01)
- (21) International Application Number:
PCT/US2012/042630
- (22) International Filing Date:
15 June 2012 (15.06.2012)
- (25) Filing Language: English
- (26) Publication Language: English
- (30) Priority Data:
61/497,335 15 June 2011 (15.06.2011) US
- (71) Applicant (for all designated States except US): **INTER-DIGITAL PATENT HOLDINGS, INC.** [US/US]; 3411 Silverside Road, Concord Plaza, Suite 105, Hagley Building, Wilmington, Delaware 19810 (US).
- (72) Inventors; and
- (75) Inventors/Applicants (for US only): **PURKAYASTHA, Debashish** [US/US]; 1200 East Autumn Court, Collegeville, Pennsylvania 19426 (US). **LIU, Hang** [US/US]; 486 Keating Drive, Yardley, Pennsylvania 19067 (US). **LOTFALLAH, Osama** [EG/US]; 518 Crooked Lane, King of Prussia, Pennsylvania 19406 (US). **PATEL, Milan** [GB/GB]; 8 Greville House, Lower Road, Harrow, Middlesex GB HA2 0HB (GB). **KARAMPATIS, Dimitrios** [GR/GB]; 24 Shepherds Lane, Caversham Reading RG4 7JL (GB). **SHAHEEN, Kamel M.** [US/US]; 429 Ashton Drive, King of Prussia, Pennsylvania 19406 (US).

- (74) Agent: **GUSHUE, Joseph P.**; Volpe and Koenig, P.C., United Plaza, Suite 1600, 30 S. 17th Street, Philadelphia, Pennsylvania 19103 (US).
- (81) Designated States (unless otherwise indicated, for every kind of national protection available): AE, AG, AL, AM, AO, AT, AU, AZ, BA, BB, BG, BH, BR, BW, BY, BZ, CA, CH, CL, CN, CO, CR, CU, CZ, DE, DK, DM, DO, DZ, EC, EE, EG, ES, FI, GB, GD, GE, GH, GM, GT, HN, HR, HU, ID, IL, IN, IS, JP, KE, KG, KM, KN, KP, KR, KZ, LA, LC, LK, LR, LS, LT, LU, LY, MA, MD, ME, MG, MK, MN, MW, MX, MY, MZ, NA, NG, NI, NO, NZ, OM, PE, PG, PH, PL, PT, QA, RO, RS, RU, RW, SC, SD, SE, SG, SK, SL, SM, ST, SV, SY, TH, TJ, TM, TN, TR, TT, TZ, UA, UG, US, UZ, VC, VN, ZA, ZM, ZW.
- (84) Designated States (unless otherwise indicated, for every kind of regional protection available): ARIPO (BW, GH, GM, KE, LR, LS, MW, MZ, NA, RW, SD, SL, SZ, TZ, UG, ZM, ZW), Eurasian (AM, AZ, BY, KG, KZ, RU, TJ, TM), European (AL, AT, BE, BG, CH, CY, CZ, DE, DK, EE, ES, FI, FR, GB, GR, HR, HU, IE, IS, IT, LT, LU, LV, MC, MK, MT, NL, NO, PL, PT, RO, RS, SE, SI, SK, SM, TR), OAPI (BF, BJ, CF, CG, CI, CM, GA, GN, GQ, GW, ML, MR, NE, SN, TD, TG).

Published:
— with international search report (Art. 21(3))

[Continued on next page]

(54) Title: METHOD AND APPARATUS FOR DELIVERING CONTENT TO A ROAMING MOBILE STATION USING AN IMS INFRASTRUCTURE

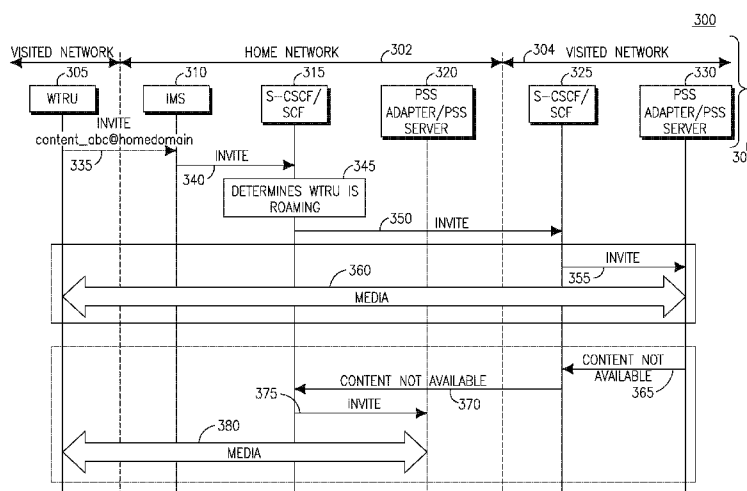

FIG. 3

(57) Abstract: A method and apparatus are described for delivering content object or multimedia service ("content") to a wireless transmit/receive unit (WTRU) roaming in a visited network. In one example, the roaming WTRU sends a request message to a home or visited network. The home or visiting network determines that the WTRU is roaming and availability of the requested content at the visited network. A media path may be established between the WTRU and the visited network/home network on a condition that the requested content is available/unavailable at the visited network. In another example, the home or visiting network may determine an optimal content location and send an indication to the WTRU or a network node to obtain the requested content from the optimal content location. The optimal content location is learnt from content location information obtained from request messages, response messages, subscriptions and published information.

WO 2012/174355 A1

- *before the expiration of the time limit for amending the claims and to be republished in the event of receipt of amendments (Rule 48.2(h))*

METHOD AND APPARATUS FOR DELIVERING CONTENT TO A ROAMING MOBILE STATION USING AN IMS INFRASTRUCTURE

CROSS REFERENCE TO RELATED APPLICATIONS

[0001] This application claims the benefit of U.S. provisional application No. 61/497,335, filed June 15, 2011, the contents of which are hereby incorporated by reference herein.

TECHNICAL FIELD

[0002] This application is related to wireless communications.

BACKGROUND

[0003] In Internet Protocol (IP) multimedia subsystem (IMS) mobile networks, a content object or multimedia service request from a wireless transmit/receive unit (WTRU) roaming in a visited network may be sent to the WTRU's home network to obtain the content object or multimedia service. The home network, (for example, a home network session control function (SCF) and/or packet switch streaming (PSS) adapter), may not know whether the requested content object or multimedia service is available in the visited network, and therefore selects the home network server to serve the request. This approach may not be ideal from a subscriber's perspective and a service provider's perspective as it may introduce delay and use more network resources.

SUMMARY

[0004] A method and apparatus are described for delivering content object or multimedia service ("content") to a wireless transmit/receive unit (WTRU) roaming in a visited network. In one example, the roaming WTRU sends a request message to a home or visited network. The home or visiting network determines that the WTRU is roaming and availability of the requested content at the visited network. A media path may be established between the WTRU and the visited network/home network on a condition that the requested content is available/unavailable at the visited network. In another example, the home or visiting network may determine an optimal content location and send an

indication to the WTRU or a network node to obtain the requested content from the optimal content location. The optimal content location is learnt from content location information obtained from request messages, response messages, subscriptions and published information.

BRIEF DESCRIPTION OF THE DRAWINGS

[0005] A more detailed understanding may be had from the following description, given by way of example in conjunction with the accompanying drawings wherein:

[0006] Figure 1A shows an example communications system in which one or more disclosed embodiments may be implemented;

[0007] Figure 1B shows an example wireless transmit/receive unit (WTRU), (i.e., a STA), that may be used within the communications system illustrated in Figure 1A;

[0008] Figure 1C shows an example radio access network and an example core network that may be used within the communications system illustrated in Figure 1A;

[0009] Figure 2 shows a multimedia system including an Internet Protocol (IP) multimedia subsystem (IMS) home network and an IMS visited network;

[0010] Figure 3 shows an example signal flow diagram of the home network determining content object or multimedia service availability;

[0011] Figure 4 shows an example signal flow diagram with content object or multimedia service location tracking and learning functionality;

[0012] Figure 5 shows an example signal flow diagram with content object or multimedia service publication; and

[0013] Figure 6 shows an example signal flow diagram with content object or multimedia service location and network topology information.

DETAILED DESCRIPTION

[0014] Figure 1A is a diagram of an example communications system 100 in which one or more disclosed embodiments may be implemented. The communications system 100 may be a multiple access system that provides

content, such as voice, data, video, messaging, broadcast, and the like, to multiple wireless users. The communications system 100 may enable multiple wireless users to access such content through the sharing of system resources, including wireless bandwidth. For example, the communications systems 100 may employ one or more channel access methods, such as code division multiple access (CDMA), time division multiple access (TDMA), frequency division multiple access (FDMA), orthogonal FDMA (OFDMA), single-carrier FDMA (SC-FDMA), and the like.

[0015] As shown in Figure 1A, the communications system 100 may include wireless transmit/receive units (WTRUs) 102a, 102b, 102c, 102d, (i.e., STAs), a radio access network (RAN) 104, a core network 106, a public switched telephone network (PSTN) 108, the Internet 110, and other networks 112, though it may be appreciated that the disclosed embodiments contemplate any number of WTRUs, base stations, networks, and/or network elements. Each of the WTRUs 102a, 102b, 102c, 102d may be any type of device configured to operate and/or communicate in a wireless environment. By way of example, the WTRUs 102a, 102b, 102c, 102d may be configured to transmit and/or receive wireless signals and may include user equipment (UE), a mobile station, a fixed or mobile subscriber unit, a pager, a cellular telephone, a personal digital assistant (PDA), a smartphone, a laptop, a netbook, a personal computer, a wireless sensor, consumer electronics, and the like.

[0016] The communications systems 100 may also include a base station 114a and a base station 114b. Each of the base stations 114a, 114b may be any type of device configured to wirelessly interface with at least one of the WTRUs 102a, 102b, 102c, 102d to facilitate access to one or more communication networks, such as the core network 106, the Internet 110, and/or the networks 112. By way of example, the base stations 114a, 114b may be a base transceiver station (BTS), a Node-B, an evolved Node-B (eNB), a Home Node-B (HNB), a Home eNB (HeNB), a site controller, an access point (AP), a wireless router, and the like. While the base stations 114a, 114b are each depicted as a single element, it may be appreciated that the base stations 114a, 114b may include any number of interconnected base stations and/or network elements.

[0017] The base station 114a may be part of the RAN 104, which may also include other base stations and/or network elements (not shown), such as a base station controller (BSC), a radio network controller (RNC), relay nodes, and the like. The base station 114a and/or the base station 114b may be configured to transmit and/or receive wireless signals within a particular geographic region, which may be referred to as a cell (not shown). The cell may further be divided into cell sectors. For example, the cell associated with the base station 114a may be divided into three sectors. Thus, in one embodiment, the base station 114a may include three transceivers, i.e., one for each sector of the cell. In another embodiment, the base station 114a may employ multiple-input multiple output (MIMO) technology and, therefore, may utilize multiple transceivers for each sector of the cell.

[0018] The base stations 114a, 114b may communicate with one or more of the WTRUs 102a, 102b, 102c, 102d over an air interface 116, which may be any suitable wireless communication link (e.g., radio frequency (RF), microwave, infrared (IR), ultraviolet (UV), visible light, and the like). The air interface 116 may be established using any suitable radio access technology (RAT).

[0019] More specifically, as noted above, the communications system 100 may be a multiple access system and may employ one or more channel access schemes, such as CDMA, TDMA, FDMA, OFDMA, SC-FDMA, and the like. For example, the base station 114a in the RAN 104 and the WTRUs 102a, 102b, 102c may implement a radio technology such as universal mobile telecommunications system (UMTS) terrestrial radio access (UTRA), which may establish the air interface 116 using wideband CDMA (WCDMA). WCDMA may include communication protocols such as high-speed packet access (HSPA) and/or evolved HSPA (HSPA+). HSPA may include high-speed downlink (DL) packet access (HSDPA) and/or high-speed uplink (UL) packet access (HSUPA).

[0020] In another embodiment, the base station 114a and the WTRUs 102a, 102b, 102c may implement a radio technology such as evolved UMTS terrestrial radio access (E-UTRA), which may establish the air interface 116 using long term evolution (LTE) and/or LTE-advanced (LTE-A).

[0021] In other embodiments, the base station 114a and the WTRUs 102a, 102b, 102c may implement radio technologies such as IEEE 802.16 (i.e., worldwide interoperability for microwave access (WiMAX)), CDMA2000, CDMA2000 1X, CDMA2000 EV-DO, Interim Standard 2000 (IS-2000), Interim Standard 95 (IS-95), Interim Standard 856 (IS-856), global system for mobile communications (GSM), enhanced data rates for GSM evolution (EDGE), GSM EDGE (GERAN), and the like.

[0022] The base station 114b in Figure 1A may be a wireless router, HNB, HeNB, or AP, for example, and may utilize any suitable RAT for facilitating wireless connectivity in a localized area, such as a place of business, a home, a vehicle, a campus, and the like. In one embodiment, the base station 114b and the WTRUs 102c, 102d may implement a radio technology such as IEEE 802.11 to establish a wireless local area network (WLAN). In another embodiment, the base station 114b and the WTRUs 102c, 102d may implement a radio technology such as IEEE 802.15 to establish a wireless personal area network (WPAN). In yet another embodiment, the base station 114b and the WTRUs 102c, 102d may utilize a cellular-based RAT, (e.g., WCDMA, CDMA2000, GSM, LTE, LTE-A, and the like), to establish a picocell or femtocell. As shown in Figure 1A, the base station 114b may have a direct connection to the Internet 110. Thus, the base station 114b may not be required to access the Internet 110 via the core network 106.

[0023] The RAN 104 may be in communication with the core network 106, which may be any type of network configured to provide voice, data, applications, and/or voice over internet protocol (VoIP) services to one or more of the WTRUs 102a, 102b, 102c, 102d. For example, the core network 106 may provide call control, billing services, mobile location-based services, pre-paid calling, Internet connectivity, video distribution, and the like, and/or perform high-level security functions, such as user authentication. Although not shown in Figure 1A, it may be appreciated that the RAN 104 and/or the core network 106 may be in direct or indirect communication with other RANs that employ the same RAT as the RAN 104 or a different RAT. For example, in addition to being connected to the RAN 104, which may be utilizing an E-UTRA radio technology, the core network 106

may also be in communication with another RAN (not shown) employing a GSM radio technology.

[0024] The core network 106 may also serve as a gateway for the WTRUs 102a, 102b, 102c, 102d to access the PSTN 108, the Internet 110, and/or other networks 112. The PSTN 108 may include circuit-switched telephone networks that provide plain old telephone service (POTS). The Internet 110 may include a global system of interconnected computer networks and devices that use common communication protocols, such as the transmission control protocol (TCP), user datagram protocol (UDP) and the internet protocol (IP) in the TCP/IP internet protocol suite. The networks 112 may include wired or wireless communications networks owned and/or operated by other service providers. For example, the networks 112 may include another core network connected to one or more RANs, which may employ the same RAT as the RAN 104 or a different RAT.

[0025] Some or all of the WTRUs 102a, 102b, 102c, 102d in the communications system 100 may include multi-mode capabilities, i.e., the WTRUs 102a, 102b, 102c, 102d may include multiple transceivers for communicating with different wireless networks over different wireless links. For example, the WTRU 102c shown in Figure 1A may be configured to communicate with the base station 114a, which may employ a cellular-based radio technology, and with the base station 114b, which may employ an IEEE 802 radio technology.

[0026] Figure 1B is a system diagram of an example WTRU 102. As shown in Figure 1B, the WTRU 102 may include a processor 118, a transceiver 120, a transmit/receive element 122, a speaker/microphone 124, a keypad 126, a display/touchpad 128, non-removable memory 106, removable memory 132, a power source 134, a global positioning system (GPS) chipset 136, and other peripherals 138. It may be appreciated that the WTRU 102 may include any sub-combination of the foregoing elements while remaining consistent with an embodiment.

[0027] The processor 118 may be a general purpose processor, a special purpose processor, a conventional processor, a digital signal processor (DSP), a plurality of microprocessors, one or more microprocessors in association with a DSP core, a controller, a microcontroller, Application Specific Integrated Circuits

(ASICs), Field Programmable Gate Array (FPGAs) circuits, any other type of integrated circuit (IC), a state machine, and the like. The processor 118 may perform signal coding, data processing, power control, input/output processing, and/or any other functionality that enables the WTRU 102 to operate in a wireless environment. The processor 118 may be coupled to the transceiver 120, which may be coupled to the transmit/receive element 122. While Figure 1B depicts the processor 118 and the transceiver 120 as separate components, it may be appreciated that the processor 118 and the transceiver 120 may be integrated together in an electronic package or chip.

[0028] The transmit/receive element 122 may be configured to transmit signals to, or receive signals from, a base station (e.g., the base station 114a) over the air interface 116. For example, in one embodiment, the transmit/receive element 122 may be an antenna configured to transmit and/or receive RF signals. In another embodiment, the transmit/receive element 122 may be an emitter/detector configured to transmit and/or receive IR, UV, or visible light signals, for example. In yet another embodiment, the transmit/receive element 122 may be configured to transmit and receive both RF and light signals. It may be appreciated that the transmit/receive element 122 may be configured to transmit and/or receive any combination of wireless signals.

[0029] In addition, although the transmit/receive element 122 is depicted in Figure 1B as a single element, the WTRU 102 may include any number of transmit/receive elements 122. More specifically, the WTRU 102 may employ MIMO technology. Thus, in one embodiment, the WTRU 102 may include two or more transmit/receive elements 122 (e.g., multiple antennas) for transmitting and receiving wireless signals over the air interface 116.

[0030] The transceiver 120 may be configured to modulate the signals that are to be transmitted by the transmit/receive element 122 and to demodulate the signals that are received by the transmit/receive element 122. As noted above, the WTRU 102 may have multi-mode capabilities. Thus, the transceiver 120 may include multiple transceivers for enabling the WTRU 102 to communicate via multiple RATs, such as UTRA and IEEE 802.11, for example.

[0031] The processor 118 of the WTRU 102 may be coupled to, and may receive user input data from, the speaker/microphone 124, the keypad 126, and/or the display/touchpad 128 (e.g., a liquid crystal display (LCD) display unit or organic light-emitting diode (OLED) display unit). The processor 118 may also output user data to the speaker/microphone 124, the keypad 126, and/or the display/touchpad 128. In addition, the processor 118 may access information from, and store data in, any type of suitable memory, such as the non-removable memory 106 and/or the removable memory 132. The non-removable memory 106 may include random-access memory (RAM), read-only memory (ROM), a hard disk, or any other type of memory storage device. The removable memory 132 may include a subscriber identity module (SIM) card, a memory stick, a secure digital (SD) memory card, and the like. In other embodiments, the processor 118 may access information from, and store data in, memory that is not physically located on the WTRU 102, such as on a server or a home computer (not shown).

[0032] The processor 118 may receive power from the power source 134, and may be configured to distribute and/or control the power to the other components in the WTRU 102. The power source 134 may be any suitable device for powering the WTRU 102. For example, the power source 134 may include one or more dry cell batteries (e.g., nickel-cadmium (NiCd), nickel-zinc (NiZn), nickel metal hydride (NiMH), lithium-ion (Li-ion), and the like), solar cells, fuel cells, and the like.

[0033] The processor 118 may also be coupled to the GPS chipset 136, which may be configured to provide location information, (e.g., longitude and latitude), regarding the current location of the WTRU 102. In addition to, or in lieu of, the information from the GPS chipset 136, the WTRU 102 may receive location information over the air interface 116 from a base station, (e.g., base stations 114a, 114b), and/or determine its location based on the timing of the signals being received from two or more nearby base stations. It may be appreciated that the WTRU 102 may acquire location information by way of any suitable location-determination method while remaining consistent with an embodiment.

[0034] The processor 118 may further be coupled to other peripherals 138, which may include one or more software and/or hardware modules that provide additional features, functionality and/or wired or wireless connectivity. For example, the peripherals 138 may include an accelerometer, an e-compass, a satellite transceiver, a digital camera (for photographs or video), a universal serial bus (USB) port, a vibration device, a television transceiver, a hands free headset, a Bluetooth® module, a frequency modulated (FM) radio unit, a digital music player, a media player, a video game player module, an Internet browser, and the like.

[0035] Figure 1C shows an example RAN 104 and an example core network 106 that may be used within the communications system 100 shown in Figure 1A. The RAN 104 may be an access service network (ASN) that employs IEEE 802.16 radio technology to communicate with the WTRUs 102a, 102b, 102c over the air interface 116.

[0036] As shown in Figure 1C, the RAN 104 may include base stations 140a, 140b, 140c, and an ASN gateway 142, though it will be appreciated that the RAN 104 may include any number of base stations and ASN gateways while remaining consistent with an embodiment. The base stations 140a, 140b, 140c may each be associated with a particular cell (not shown) in the RAN 104 and may each include one or more transceivers for communicating with the WTRUs 102a, 102b, 102c over the air interface 116. In one embodiment, the base stations 140a, 140b, 140c may implement MIMO technology. Thus, the base station 140a, for example, may use multiple antennas to transmit wireless signals to, and receive wireless signals from, the WTRU 102a. The base stations 140a, 140b, 140c may also provide mobility management functions, such as handoff triggering, tunnel establishment, radio resource management, traffic classification, quality of service (QoS) policy enforcement, and the like. The ASN gateway 142 may serve as a traffic aggregation point and may be responsible for paging, caching of subscriber profiles, routing to the core network 106, and the like.

[0037] The air interface 116 between the WTRUs 102a, 102b, 102c and the RAN 104 may implement the IEEE 802.16 specification. In addition, each of the

WTRUs 102a, 102b, 102c may establish a logical interface (not shown) with the core network 106. The logical interface between the WTRUs 102a, 102b, 102c and the core network 106 may be used for authentication, authorization, IP host configuration management, and/or mobility management.

[0038] The communication link between each of the base stations 140a, 140b, 140c may include protocols for facilitating WTRU handovers and the transfer of data between base stations. The communication link between the base stations 140a, 140b, 140c and the ASN gateway 142 may include protocols for facilitating mobility management based on mobility events associated with each of the WTRUs 102a, 102b, 102c.

[0039] As shown in Figure 1C, the RAN 104 may be connected to the core network 106. The communication link between the RAN 104 and the core network 106 may include protocols for facilitating data transfer and mobility management capabilities, for example. The core network 106 may include a mobile IP home agent (MIP-HA) 144, an authentication, authorization, accounting (AAA) server 146, and a gateway 148. While each of the foregoing elements are depicted as part of the core network 106, it will be appreciated that any one of these elements may be owned and/or operated by an entity other than the core network operator.

[0040] The MIP-HA may be responsible for IP address management, and may enable the WTRUs 102a, 102b, 102c to roam between different ASNs and/or different core networks. The MIP-HA 144 may provide the WTRUs 102a, 102b, 102c with access to packet-switched networks, such as the Internet 110, to facilitate communications between the WTRUs 102a, 102b, 102c and IP-enabled devices. The AAA server 146 may be responsible for user authentication and for supporting user services. The gateway 148 may facilitate interworking with other networks. For example, the gateway 148 may provide the WTRUs 102a, 102b, 102c with access to circuit-switched networks, such as the PSTN 108, to facilitate communications between the WTRUs 102a, 102b, 102c and traditional land-line communications devices. In addition, the gateway 148 may provide the WTRUs 102a, 102b, 102c with access to the networks 112, which may include

other wired or wireless networks that are owned and/or operated by other service providers.

[0041] Although not shown in Figure 1C, it will be appreciated that the RAN 104 may be connected to other ASNs and the core network 106 may be connected to other core networks. The communication link between the RAN 104 and the other ASNs may include protocols for coordinating the mobility of the WTRUs 102a, 102b, 102c between the RAN 104 and the other ASNs. The communication link between the core network 106 and the other core networks may include protocols for facilitating interworking between home core networks and visited core networks.

[0042] As the availability grows in different networks, it may be possible that the optimal location of the content may not be in the visited or home network. It may be available in another network operator domain. The examples and embodiments described herein may be used to traverse across a network boundary to retrieve contents for another network domain.

[0043] Figure 2 shows an example multimedia system 200 including an Internet Protocol (IP) multimedia subsystem (IMS) visitor network 205 for a WTRU 215 and an IMS home network 210 for a WTRU 215. The IMS network 205 may include a Proxy-Call Session Control Function (P-CSCF) 220, an Interrogating-CSCF (I-CSCF) 222, Interconnection Border Control Function (IBCF) 224, and a Serving-CSCF (S-CSCF) 226. The P-CSCF 220 may be the entry point for the WTRU 215 into the IMS network 205. A home subscriber server (HSS) 228 may be in communication with the I-CSCF 222 and a domain name server (DNS) 230 may be in communication with the S-CSCF 226, which in turn may be in communication with an application server (AS) 232 acting as a session control function (SCF). The AS/SCF 232 may be in communication with a packet switch streaming (PSS) server/media server 234 through S-CSCF 226 and a packet switch streaming (PSS) adapter 233. If the media server 234 does not support IMS SIP, the PSS adapter 233 is needed to translate between the IMS SIP messages and other protocol messages, for example Real Time Streaming Protocol (RTSP) or Hypertext Transfer Protocol (HTTP), that the media server 234 supports. The IMS network 210 may include a P-CSCF 240, an I-CSCF 242,

an IBCF 244 that may be in communication with the IBCF 224, and an S-CSCF 246. A HSS 248 may be in communication with the I-CSCF 242 and the S-CSCF 246 may be in communication with an AS 250 acting as a SCF. The AS/SCF 250 may be in communication with a PSS server/media server 252 through S-CSCF 246 and a PSS adapter 251.

[0044] The WTRU 215 may request content object or multimedia services, (collectively referred to as “content”), when the WTRU 215 visits the IMS network visitor 205. Using a conventional method, the content request may be routed to the IMS home network 210. A media path 270, 272 and 274 may be established over a visited IP connectivity access network (IP-CAN), visited core network, and home core network between the WTRU 215 and the media server 252. This setup may not be optimal. The IMS home network 210 may have the same content requested by the WTRU 215 and therefore it may be more efficient to route the request to the S-CSCF/SCF, and then to a visited Packet-switched Streaming Service (PSS) adapter/content or media server 234, (as shown by media 276). This may result in a shorter path and less delay. As stated above, if the PSS/media server 252 does not support IMS, the PSS adapter 251 is needed to translate between the IMS SIP and other protocols such as RTSP or HTTP. The PSS adapter 233 and 251 may be a separate box between CSCF and the media server 234 or 252 or integrated with the media server 234 or 252, respectively.

[0045] Described herein are routing methods and architecture which route the requests from a roaming WTRU to the closest available content server. In these example routing methods, the IMS networks may be aware of the location of the content being requested via publish or subscribe mechanisms. Based on this awareness, various routing methods are described herein below.

[0046] The methods herein further utilize routing based on a unique “content ID” or “service ID” in the IMS network. A content ID or service ID (collectively “content ID”) may be a uniform resource identifier (URI), a flat name, a hierarchical name or in other forms that uniquely identifies the content. Described herein are how the content ID and its location map may be developed and how this map may be used to route requests to an optimal server location.

[0047] The content may be given a globally unique name, ID or URI. The name or ID may be assigned to the content by the content author, service provider, or some naming authority, which is independent of the locations of the content. Different naming schemes may be used. For example, the content may be assigned a flat name with the form P:L, where P is a cryptographic hash of the principal's public key and L is the flat label. Alternatively, the hash of the content may be used as its name. In another example, the content may be assigned to a hierarchical name in the form of /author domain/category/title, for example, /example.com/news/abc. The terms, "ID", "identifier", URI, and "name" may be used interchangeably, unless otherwise stated.

[0048] The content may be replicated in different locations. For example, the content may be available in both the visited network and the home network of a roaming WTRU. In such a case, the requested content may be provided by the visited network.

[0049] Described herein is an on-demand search method. Figure 3 shows an example signal flow diagram 300 for a multimedia system 301 that may include a home network 302 that determines content availability at a visited network 304. A WTRU 305 may be roaming in the visited network 304. A home network 302 may include a home network IMS 310, a home network S-CSCF/SCF 315, and a home network PSS adapter/PSS server 320. The visited network 304 may include a visited network S-CSCF/SCF 325 and a visited network PSS adapter/PSS server 330.

[0050] Although network nodes, such as an SCF and a PSS adapter/PSS server, are mentioned when describing the example methods herein, it should be understood by one of ordinary skill in the art that other types of nodes, such as an interconnection border control function (IBCF), an interrogating CSCF (I-CSCF), an application server (AS) or other nodes, may be implemented to perform these same examples or embodiments. Although the home networks and visited networks are illustrated with certain types of nodes, other types of nodes are not excluded and may be included. Although the example methods are illustrated in terms of Session Initiation Protocol (SIP) signaling protocol terminology, other protocols may also be used. The network nodes may be

implemented as servers, and other processing systems as described herein and are capable of receiving, transmitting, sending or distributing information and/or signals as described herein. In addition, the network nodes may be configured as defined herein for WTRUs and/or base stations.

[0051] An on-demand search method may be implemented in which the home network S-CSCF/SCF 315 forwards a request to the visited network S-CSCF/SCF 325 once it receives a content request with a content ID from the roaming WTRU 305. The visited network S-CSCF/SCF 325 attempts to get the requested content from the visited network PSS adapter/PSS server 330 by selecting and forwarding the request to the visited network PSS adapter/server 330. If the visited network 304 does not have the requested content, the visited network S-CSCF/SCF 325 sends a “no content/service” signal back to the home network S-CSCF/SCF 315. The home network S-CSCF/SCF 315 sends the request to the home network PSS adapter/PSS server 320.

[0052] As shown in Figure 3, the WTRU 305 in the visited network 304 requests content from the home network 302 by sending an INVITE request message to the home network S-CSCF/SCF 315 (340) through the IMS network 310 and/or other networks (335). The INVITE request message may contain the global unique ID or URI of the content requested by the WTRU 305. Alternatively, the INVITE message may contain a Uniform Resource Locator (URL) which consists of the global unique ID or URI of the requested content and a domain identifier. For example, the URL may be content_abc@homedomain, where content_abc is the global unique ID of the requested content and homedomain is the domain at which the content was originally stored at, i.e. the origin server of the requested content.

[0053] The home network S-CSCF/SCF 315 may determine that the WTRU 305 is roaming (345). For example, this determination may be made by comparing SIP header information. For a roaming WTRU 305, the home network S-CSCF/SCF 315 first determines if the visited network 304 has the requested piece of content object or multimedia service. This may be performed by forwarding the INVITE request message to the visited network S-CSCF/SCF 325 (350). In the event that the URL is in the INVITE request message, the home

network S-CSCF/SCF 315 may change the content URL from content_abc@homedomain to content_abc@visiteddomain.

[0054] When the visited network S-CSCF/SCF 325 receives the INVITE request message and the content identifier, it forwards the INVITE request message to the visited network PSS adapter/PSS server 330 (355). If the content is available, a media path is established between the WTRU 305 and the visited network PSS adapter/PSS server 330 (360).

[0055] If the content is not available, the visited network PSS adapter/PSS server/media server 330 responds with a “content not available” indication to the visited network S-CSCF/SCF 325 (365). The visited network S-CSCF/SCF 325 sends the “content not available” indication to the home network S-CSCF/SCF 315 (370). The home network S-CSCF/SCF 315 then sends the INVITE request message to the home network PSS adapter/PSS server 320 (375). A media path is then established between the WTRU 305 and the home network PSS adapter/PSS server 320 (380). The signaling messages between home network S-CSCF/SCF 315 and the visited network S-CSCF/SCF 325 may go through the IMS 310, i.e., the IP multimedia core network (CN) subsystem, although such signaling is not indicated in Figure 3.

[0056] Figure 4 shows an example signal flow diagram 400 with content object or multimedia service location tracking and learning functionality. An example multimedia system 401 may include a home network 402 and a visited network 404. A WTRU 405 may be roaming in the visited network 404. A visited network 404 may include a visited network IMS/P-CSCF 410, a visited network SCF 415, and a visited network PSS adapter/PSS server 420. A home network 402 may include a home network SCF 425 and a home network PSS adapter/PSS server 430.

[0057] The IMS/P-CSCF 410 and/or the S-CSCF/SCF 415 may be enhanced with content location tracking and learning functionality. The IMS/P-CSCF 410 or S-CSCF/SCF 415 tracker function may be capable of tracking and learning the content locations from routing requests and/or replies. Alternatively, the PSS adapter/PSS server (media server) 420 may publish their content object or multimedia service to the tracker function in the IMS/P-CSCF 410 and/or the S-

CSCF/SCF 415. Based on the tracking results, a content location information table/directory may be built over time which contains content information, (for example location information), available within the visited network 404.

[0058] As shown in Figure 4, the WTRU 405 in the visited network 404 requests content from the visited network 404 by sending an INVITE message to the visited network IMS/P-CSCF 410 (435). The INVITE message may contain the global unique ID or URI of the content requested by the WTRU. Alternatively, the INVITE may contain a URL which consists of the global unique ID or URI of the requested content and a domain identifier. For example, the URL may be content_abc@homedomain, where content_abc is the global unique ID of the requested content and homedomain is the domain where the content is originally stored at, (i.e., the origin server of the requested content).

[0059] As stated, the IMS/P-CSCF 410 may be updated with tracker functions. Based on previous content requests, (i.e., INVITE request messages), the IMS/P-CSCF 410 may learn information about the content availability within the local network, i.e., the visited network 404. Alternatively, the PSS adapter/PSS server (media server) 420 may publish their content to the tracker function. The content may be identified using the global unique content identifier or URIs.

[0060] Use of URLs to identify content may be problematic because the same content may have different URLs in different networks. A universal identification naming system of content may be required to identify content accurately as described herein above. For example, the URL may contain a global unique content identifier and a domain name.

[0061] The visited network IMS/P-CSCF 410 in combination with the visited network S-CSCF/SCF 425 may cache previous content requests in the IMS network to the local PSS adapters/content servers and the content hosts may also inform of their content/services to the tracker function. The combination visited network IMS/P-CSCF 410 and the visited network S-CSCF/SCF 425 may create a mapping table about the availability of content locally in its content servers.

[0062] Referring to Figure 4, the IMS/P-CSCF 410 determines if the WTRU 405 is roaming (440). For roaming WTRUs, the IMS/P-CSCF 410 applies special processing for INVITE messages. The global unique content ID within the INVITE message is searched against its content information table to determine if the content is available locally. If service level agreements (SLAs) between the home network 402 and visited network 404 are in place, then while routing INVITE messages, the IMS/P-SCF 410 may consult a cached table. If the content is available locally (445), the IMS/P-CSCF 410 may change the routing policy and may also modify the domain part of the content URL in the SIP INVITE message, (if a URL is used in the INVITE message), and forwards it to the visited network S-CSCF/SCF 415 (450). The visited network S-CSCF/SCF 415 may then forward the INVITE message to the local PSS Adapter/PSS Server 420 (455). A media path may then be established between the WTRU 405 and the visited network PSS adapter/server 420 (460).

[0063] If the requested content is not available locally (465), then the visited network IMS/P-CSCF 410 forwards the INVITE message to the home network CSCF/SCF 425 (470). In the INVITE message, the visited network IMS/P-CSCF 410 may also indicate that the requested content is not available in the visited network 404 so that the home network 402 may serve this request, (i.e., preventing a return of the INVITE message). The home network S-CSCF/SCF 425 forwards the INVITE message to the home network PSS adapter/PSS server 430 (475), and a media path is established between the WTRU 405 and the home network PSS adapter/server 430 (480).

[0064] Figure 5 shows an example signal flow diagram 500 with content publication. An example multimedia system 501 may include a home network 502 and a visited network 504. A WTRU 505 may be roaming in the visited network 504. A home network 502 may include a home network IMS 510, a home network S-CSCF/SCF 515, and a home network PSS adapter/PSS server 520. A visited network 504 may include a visited network S-CSCF/SCF 525, and a visited network PSS adapter/PSS server 530.

[0065] In this example method, the visited network PSS adapters 530 may publish available content in the visited network 504. The home network PSS

adapters 520 subscribe to the content location information published by the visited network PSS adapters 530, and redirect the content request to the visited network 504.

[0066] The WTRU 505 in the visited network 504 requests content from the home network by sending an INVITE message to the home network S-CSCF/SCF 515 (540) through IMS network 510 (535). The INVITE message may contain the global unique ID or URI of the content requested by the WTRU 505. Alternatively, the INVITE message may contain a Uniform Resource Locator (URL) which consists of the global unique ID or URI of the requested content and a domain identifier. For example, the URL may be content_abc@homedomain, where content_abc is the global unique ID of the requested content and homedomain is the domain at which the content was originally stored, i.e. the origin server of the requested content.

[0067] The home network S-CSCF/SCF 515 forwards the INVITE message to the home network PSS adapter/PSS server 520 (545). The home network PSS adapter/PSS server 520 determines that the WTRU 505 is roaming, (this may be performed by comparing the SIP header information). The home network PSS adapter/PSS server 520 has knowledge, (via its tracker functions), about the requested content such as whether it is available in a more optimal location in terms of retrieval/download cost by the roaming WTRU 505. It may be possible that the requested content is available within the visited network 504. The home network PSS adapter/PSS server 520 informs the home network S-CSCF/SCF 515 about the visited network PSS adapter/server 530 by sending a RE-DIRECT message (550).

[0068] As described herein, tracker functionality may be added to the home network PSS adapter/PSS server 520 and the visited network PSS adapter/PSS server 530. When a change occurs in the content servers in the visited network 504, (i.e., new content is added or existing content is removed), the content servers of the visiting network 504 may inform the visited network PSS adapter 530. The visited network PSS adapter/PSS server 530 may publish the change, and the home network PSS adapter/PSS server 520 may subscribe to the content location information published by the visited network PSS adapter/PSS server

530. In this fashion, the tracker function in the home network PSS adapter/PSS server 520 has up-to-date information of available content in the visited network 504. The combination of the PSS adapter and the tracker function helps in routing of the content request.

[0069] The home network S-CSCF/SCF 515 may change the content URL from content_abc@homedomain to content_abc@visiteddomain, (if the URL is contained in the INVITE message), and may send an INVITE message to the visited network S-CSCF/SCF 525 (555). When the visited network S-CSCF/SCF 525 receives the INVITE message, it may forward the INVITE message to the visited network PSS adapter/PSS server 530 (560). A media path may be established between the WTRU 505 and the visited network PSS adapter/PSS server 530 (not shown).

[0070] Figure 6 shows an example signal flow diagram 600 with content location and network topology information. An example multimedia system 601 may include a home network 602 and a visited network 604. A WTRU 605 may be roaming in the visited network 604. A home network may include a home network IMS 610, a home network S-CSCF/SCF 615, and a home network PSS adapter/PSS server 620. A visited network 604 may include a visited network PSS server/Media Server 630. The PSS server/Media Server 630 may include content location and network topology information to redirect the content to another server so that the download cost is minimal. The PSS server/Media Server 630 may be able to redirect the WTRU 605, irrespective of its current location, i.e., roaming or not, to the correct content server.

[0071] The WTRU 605 in the visited network 604 may send an INVITE message with the content ID to the home network IMS 610 (635), the home network S-CSCF/SCF 615 (640) and finally to the home network PSS adapter/PSS server 620 (645). The INVITE message may contain the global unique ID or URI of the content requested by the WTRU 605. Alternatively, the INVITE message may contain a Uniform Resource Locator (URL) which consists of the global unique ID or URI of the requested content and a domain identifier. For example, the URL may be content_abc@homedomain, where content_abc is the global unique ID of the requested content and homedomain is the domain at

which the content was originally stored, i.e. the origin server of the requested content.

[0072] The home network PSS adapter/server 620 may send the content request to the visited network PSS server/Media server 630. It may be assumed that the PSS server/Media server 630 is in the Internet domain and is capable of reaching other PSS content servers. The PSS server/Media server 630 may not use IMS and may communicate using IP.

[0073] The PSS server/Media server 630 may include a content tracker function and network topology function. The PSS server/Media servers may publish their content among themselves or the PSS server/Media servers may learn the content locations via previous content requests/responses. The PSS server/Media server 630 may determine the optimal server for the roaming WTRU 605 (650). There is an increased or high possibility that the new server is located within the visited network 604. The home PSS adapter/PSS server 620 may send the information about the server to the WTRU 605 in the visited network (655). The WTRU 605 may use the new server address to retrieve the content. A media path may be established between the WTRU 605 and the PSS Server/Media Server 630 (660).

[0074] Embodiments

[0075] 1. A method, implemented in an IMS network node, for delivering content object to a wireless transmit/receive unit (WTRU) roaming in a visited network, the method comprising receiving a request message requesting the content object and including a content identifier associated with the content object.

[0076] 2. The method of embodiment 1, further comprising determining availability of the requested content object at the visited network.

[0077] 3. The method of any of the preceding embodiments, further comprising directing the WTRU to establish a media path with a content server associated with the visited network on a condition that the requested content object is available at the visited network.

[0078] 4. The method of any of the preceding embodiments, wherein a serving call session control function (S-CSCF)/session control function (SCF) in a

home network receives the request message via an Internet Protocol (IP) multimedia subsystem (IMS) and makes a WTRU roaming determination.

[0079] 5. The method of any of the preceding embodiments, wherein a roaming determination is made by comparing session initiation protocol (SIP) header information.

[0080] 6. The method of any of the preceding embodiments, further comprising forwarding the request message to a visited network packet switch streaming (PSS) adapter/PSS server.

[0081] 7. The method of any of the preceding embodiments,, further comprising the visited network PSS adapter/PSS server sending an indication to the visited network S-CSCF/SCF on the availability of the content object.

[0082] 8. The method of any of the preceding embodiments, further comprising changing, by a home network, a uniform resource locator (URL) on a condition that the URL is included in the request message.

[0083] 9. The method of any of the preceding embodiments, wherein a visited network Internet protocol (IP) multimedia subsystem (IMS)/proxy call session control function (P-CSCF) receives the request message, makes a WTRU roaming determination and determines content object availability.

[0084] 10. The method of any of the preceding embodiments, further comprising forwarding the invite message from the visited network IMS/P-CSCF to a visited network S-CSCF/SCF and a visited network packet switch streaming (PSS) adapter/server on a condition that the requested content object is available in the visited network.

[0085] 11 The method of any of the preceding embodiments, further comprising forwarding the invite message from the visited network IMS/P-CSCF to a home network S-CSCF/SCF and a home network packet switch streaming (PSS) adapter/server on a condition that the requested content object is unavailable in the visited network.

[0086] 12. The method of any of the preceding embodiments, further comprising establishing a media path between the WTRU and the home network PSS adapter/server.

[0087] 13. The method of any of the preceding embodiments, wherein a home network sends a redirect message to inform at least the WTRU an optimal location of the requested content object.

[0088] 14. The method of any of the preceding embodiments, wherein one of the visited network and a home network learns content object location through at least one of request messages, response messages, subscriptions and published information.

[0089] 15. A method, implemented in an IMS network node, for delivering content object to a wireless transmit/receive unit (WTRU), the method comprising receiving a request message requesting content object having a content identifier.

[0090] 16. The method of embodiment 15, further comprising determining from content location information an optimal content location of the requested content.

[0091] 17. The method of any one of embodiments 15-16, further comprising establishing a media path between the WTRU and a network having the optimal content.

[0092] 18. The method of any one of embodiments 15-17, wherein a redirect message is sent to inform at least the WTRU the optimal content location of the requested content.

[0093] 19. The method of any one of embodiments 15-18, wherein the content location information is learned through at least one of request messages, response messages, subscriptions and published information.

[0094] 20. A method for delivering content to a wireless transmit/receive unit (WTRU) roaming in a visited network, the method comprising the WTRU sending an invite message to a home network, the message requesting content.

[0095] 21. The method of embodiment 20, further comprising the home network determining whether the visited network has the content requested by the invite message sent by the WTRU on a condition that the WTRU is roaming.

[0096] 22. The method of any one of embodiments 20-21, further comprising establishing a media path between the WTRU and the visited

network on a condition that the visited network does not have the requested content available.

[0097] 23. The method of any one of embodiments 20-22, wherein a serving call session control function (S-CSCF)/session control function (SCF) in the home network receives the invite message via an Internet protocol (IP) multimedia subsystem (IMS) and determines whether the WTRU is roaming.

[0098] 24. The method of any one of embodiments 20-23, wherein the WTRU is determined to be roaming by comparing session initiation protocol (SIP) header information.

[0099] 25. The method of any one of embodiments 20-24, further comprising forwarding the invite message from the home network S-CSCF/SCF to a visited network S-CSCF/SCF.

[0100] 26. The method of any one of embodiments 20-25, further comprising forwarding the invite message from the visited network S-CSCF/SCF to a visited network packet switch streaming (PSS) adapter/server.

[0101] 27. The method of any one of embodiments 20-26, further comprising the PSS adapter server sending an indication to the visited network S-CSCF/SCF that the requested content is not available.

[0102] 28. The method of any one of embodiments 20-27, further comprising the home network changing a uniform resource identifier (URI) of a content identifier included in the invite message.

[0103] 29. A method for delivering content to a wireless transmit/receive unit (WTRU) roaming in a visited network, the method comprising the WTRU sending an invite message to the visited network, the message requesting content.

[0104] 30. The method of embodiment 29, further comprising the visited network determining whether the WTRU is roaming.

[0105] 31. The method of any one of embodiments 29-30, further comprising the visited network determining whether the content requested by the invite message sent by the WTRU is available in the visited network.

[0106] 32. The method of any one of embodiments 29-31, wherein a visited network Internet protocol (IP) multimedia subsystem (IMS)/proxy call

session control function (P-CSCF) receives the invite message, determines whether the WTRU is roaming and determines whether the requested content is available in the visited network.

[0107] 33. The method of any one of embodiments 29-32, further comprising forwarding the invite message from the visited network IMS/P-CSCF to a visited network S-CSCF/SCF and a visited network packet switch streaming (PSS) adapter/server on a condition that the requested content is determined to be available in the visited network.

[0108] 34. The method of any one of embodiments 29-33, further comprising establishing a media path between the WTRU and the visited network PSS adapter/server.

[0109] 35. The method of any one of embodiments 29-34, further comprising forwarding the invite message from the visited network IMS/P-CSCF to a home network S-CSCF/SCF and a home network packet switch streaming (PSS) adapter/server on a condition that the requested content is determined not to be available in the visited network.

[0110] 36. The method of any one of embodiments 29-35, further comprising establishing a media path between the WTRU and the home network PSS adapter/server.

[0111] 37. A method for delivering content to a wireless transmit/receive unit (WTRU) roaming in a visited network, the method comprising the WTRU sending an invite message to the home network, the message requesting content.

[0112] 38. The method embodiment 37, further comprising the home network determining whether the WTRU is roaming.

[0113] 39. The method of any one of embodiments 37-38, further comprising the home network sending a redirect message to inform at least a node and the WTRU about where the requested content can be obtained.

[0114] Although features and elements are described above in particular combinations, one of ordinary skill in the art may appreciate that each feature or element may be used alone or in any combination with the other features and elements. In addition, the methods described herein may be implemented in a computer program, software, or firmware incorporated in a computer-readable

medium for execution by a computer or processor. Examples of computer-readable media include electronic signals (transmitted over wired or wireless connections) and computer-readable storage media. Examples of computer-readable storage media include, but are not limited to, a read only memory (ROM), a random access memory (RAM), a register, cache memory, semiconductor memory devices, magnetic media such as internal hard disks and removable disks, magneto-optical media, and optical media such as CD-ROM disks, and digital versatile disks (DVDs). A processor in association with software may be used to implement a radio frequency transceiver for use in a WTRU, UE, terminal, base station, RNC, or any host computer.

* * *

CLAIMS

What is claimed:

1. A method, implemented in an IMS network node, for delivering content object to a wireless transmit/receive unit (WTRU) roaming in a visited network, the method comprising:

receiving a request message requesting the content object and including a content identifier associated with the content object;

determining availability of the requested content object at the visited network; and

directing the WTRU to establish a media path with a content server associated with the visited network on a condition that the requested content object is available at the visited network.

2. The method of claim 1, wherein a serving call session control function (S-CSCF)/session control function (SCF) in a home network receives the request message via an Internet Protocol (IP) multimedia subsystem (IMS) and makes a WTRU roaming determination.

3. The method of claim 1, wherein a roaming determination is made by comparing session initiation protocol (SIP) header information.

4. The method of claim 2, further comprising:
forwarding the request message to a visited network packet switch streaming (PSS) adapter/PSS server.

5. The method of claim 4, further comprising:
the visited network PSS adapter/PSS server sending an indication to the visited network S-CSCF/SCF on the availability of the content object.

6. The method of claim 1, further comprising:

changing, by a home network, a uniform resource locator (URL) on a condition that the URL is included in the request message.

7. The method of claim 1, wherein a visited network Internet protocol (IP) multimedia subsystem (IMS)/proxy call session control function (P-CSCF) receives the request message, makes a WTRU roaming determination and determines content object availability.

8. The method of claim 7, further comprising:
forwarding the invite message from the visited network IMS/P-CSCF to a visited network S-CSCF/SCF and a visited network packet switch streaming (PSS) adapter/server on a condition that the requested content object is available in the visited network.

9. The method of claim 7, further comprising:
forwarding the invite message from the visited network IMS/P-CSCF to a home network S-CSCF/SCF and a home network packet switch streaming (PSS) adapter/server on a condition that the requested content object is unavailable in the visited network.

10. The method of claim 9, further comprising:
establishing a media path between the WTRU and the home network PSS adapter/server.

11. The method of claim 1, wherein a home network sends a redirect message to inform at least the WTRU an optimal location of the requested content object.

12. The method of claim 1, wherein one of the visited network and a home network learns content object location through at least one of request messages, response messages, subscriptions and published information.

13. A method, implemented in an IMS network node, for delivering content object to a wireless transmit/receive unit (WTRU), the method comprising:

receiving a request message requesting content object having a content identifier;

determining from content location information an optimal content location of the requested content; and

establishing a media path between the WTRU and a network having the optimal content.

14. The method of claim 13, wherein a redirect message is sent to inform at least the WTRU the optimal content location of the requested content.

15. The method of claim 1, wherein the content location information is leaned through at least one of request messages, response messages, subscriptions and published information.

16. An apparatus for delivering content object to a wireless transmit/receive unit (WTRU) roaming in a visited network, comprising:

a network node configured to receive a request message requesting the content object and including a content identifier associated with the content object;

the network node configured to determine availability of the requested content object at the visited network; and

the network node configured to direct the WTRU to establish a media path with a content server associated with the visited network on a condition that the requested content object is available at the visited network.

17. The apparatus of claim 16, wherein the network node is configured to make a roaming determination by comparing session initiation protocol (SIP) header information.

18. The apparatus of claim 16, further comprising:

the network node configured to forward the request message to a visited network packet switch streaming (PSS) adapter/PSS server, wherein the visited network PSS adapter/PSS server sends an indication to a visited network a serving call session control function (S-CSCF)/session control function (SCF) on availability of the content object.

19. The apparatus of claim 16, further comprising:

the network node configured to change a uniform resource locator (URL) on a condition that the URL is included in the request message.

20. The apparatus of claim 16, wherein one of the visited network and a home network learns content object location through at least one of request messages, response messages, subscriptions and published information.

+

100

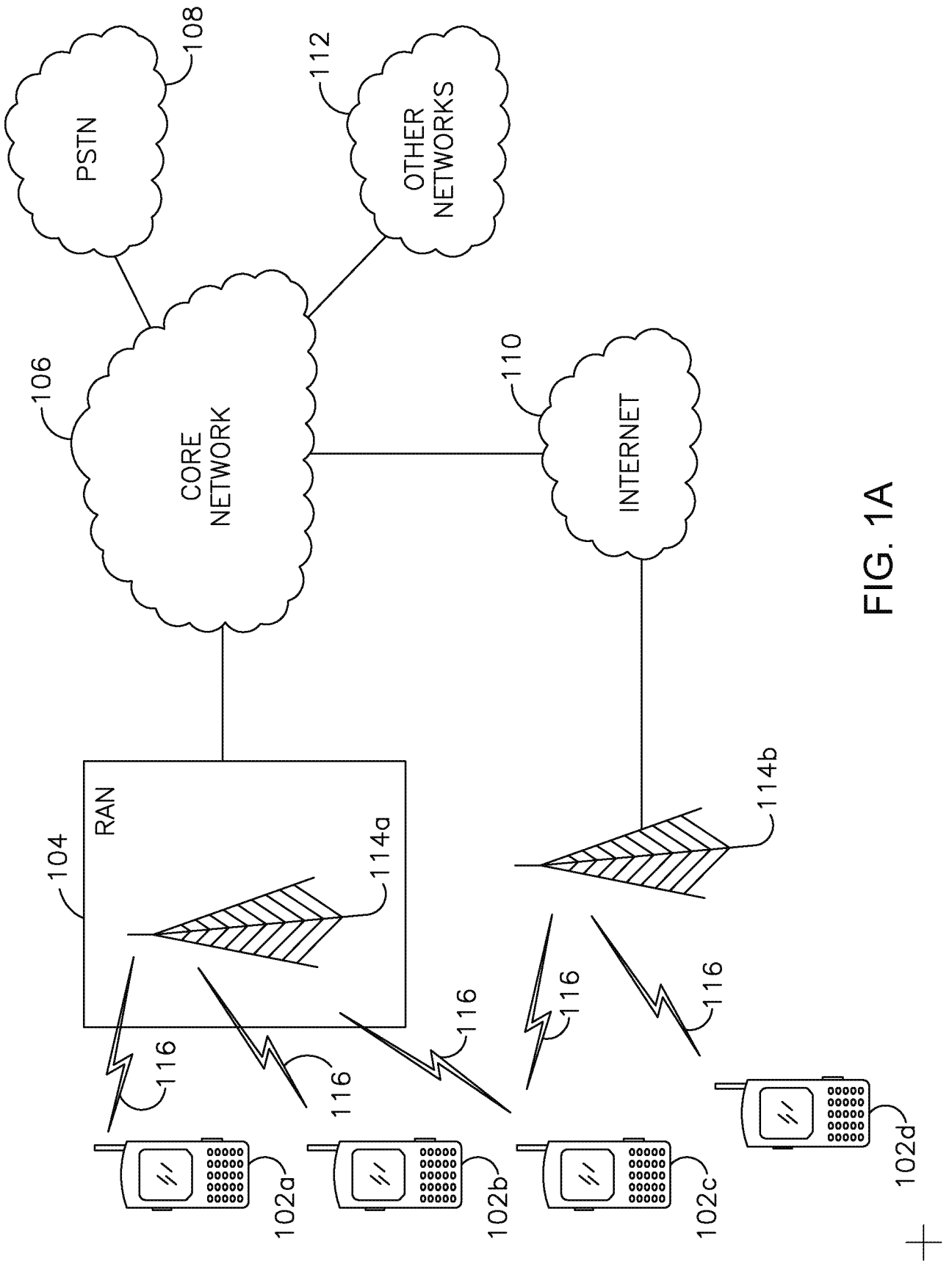

FIG. 1A

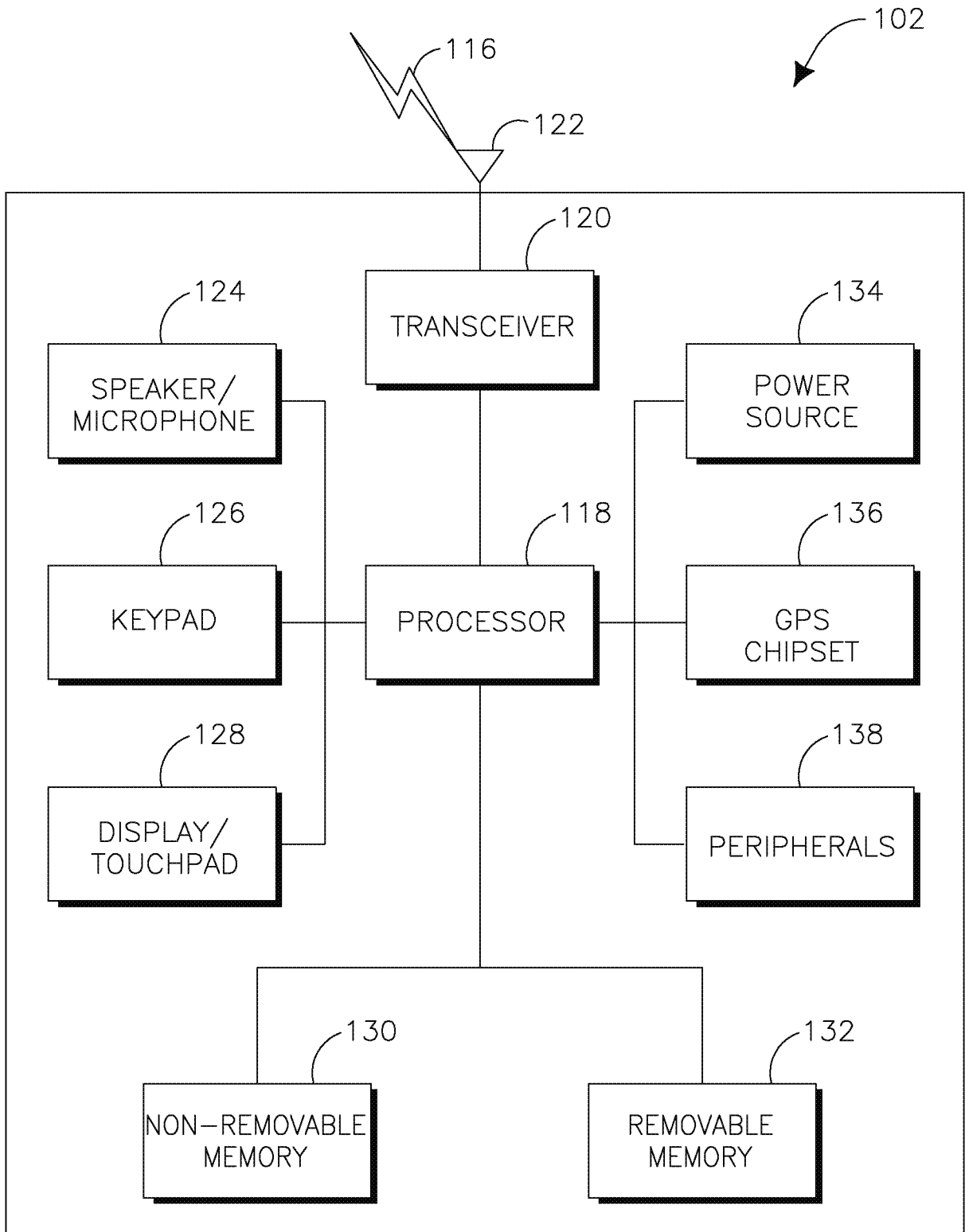

FIG. 1B

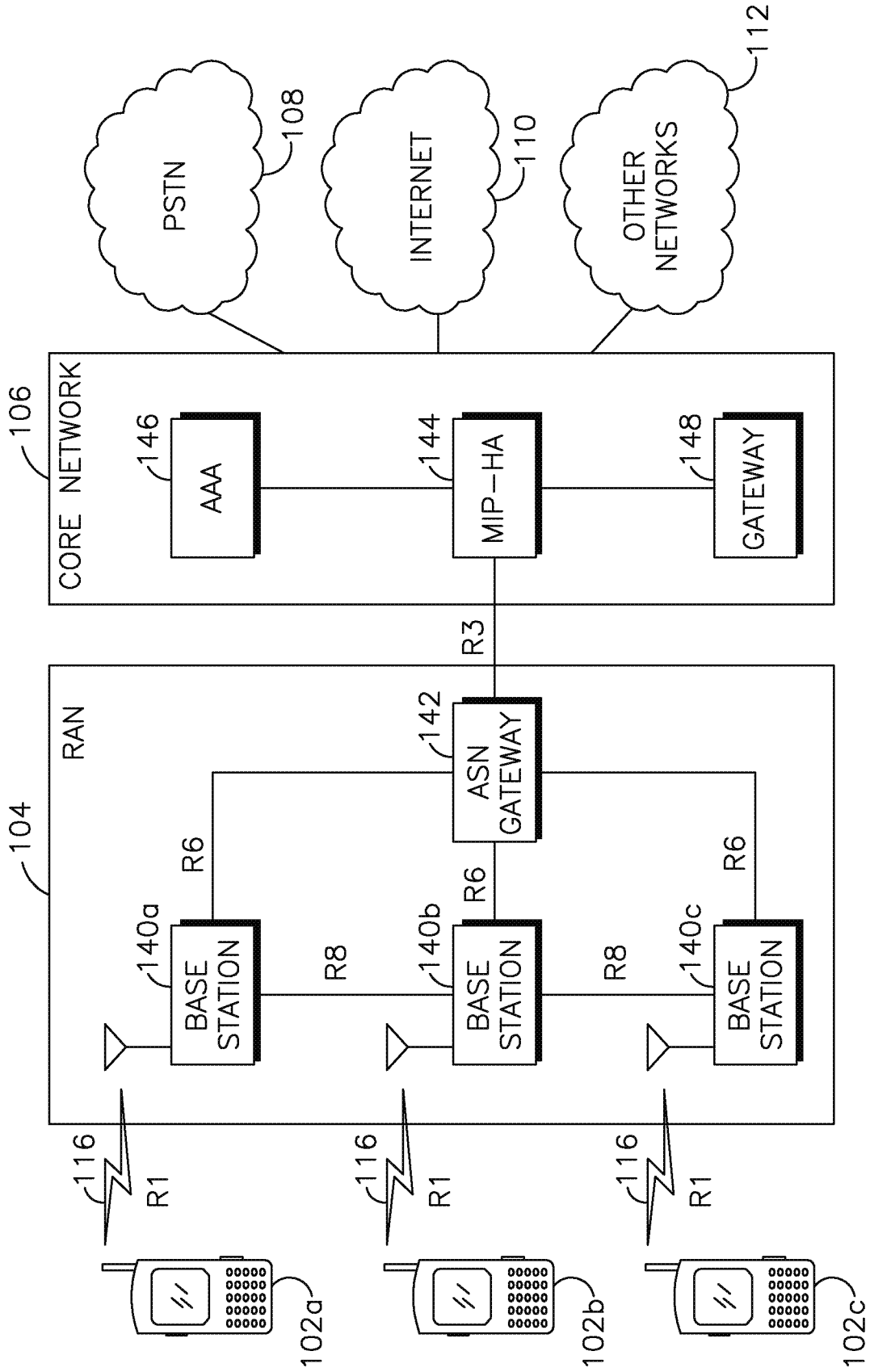

FIG. 1C



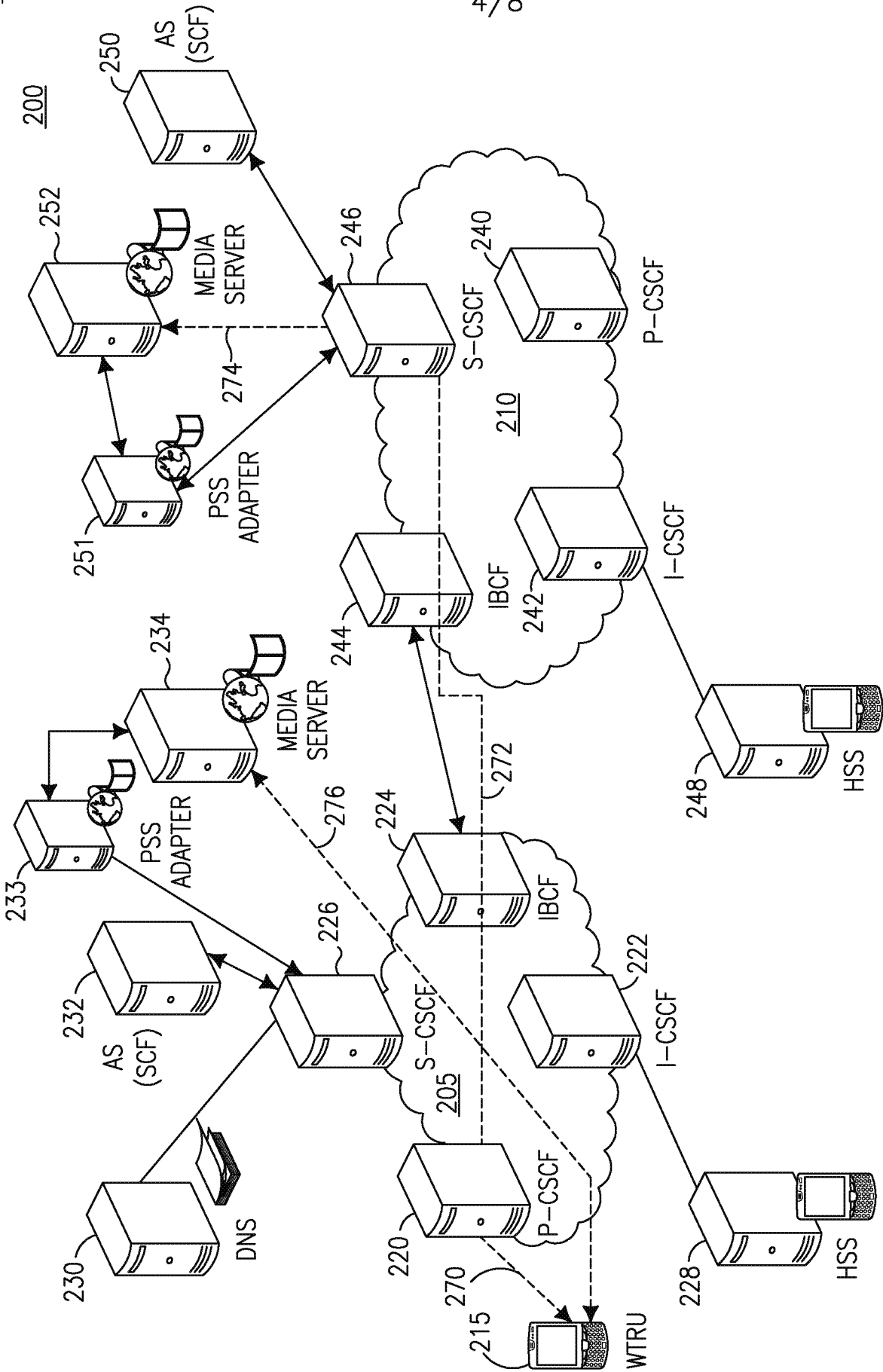

FIG. 2



300

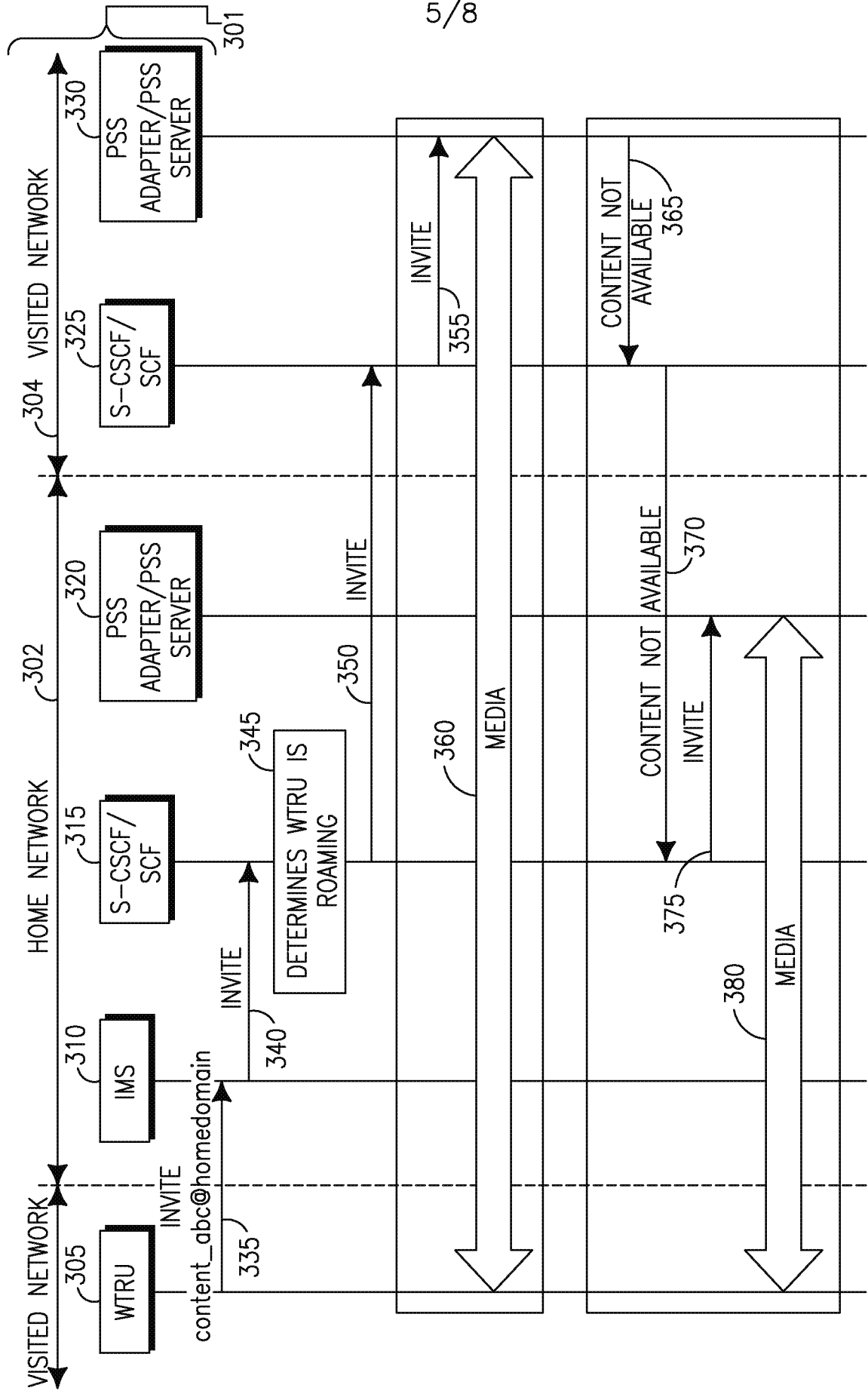

FIG. 3



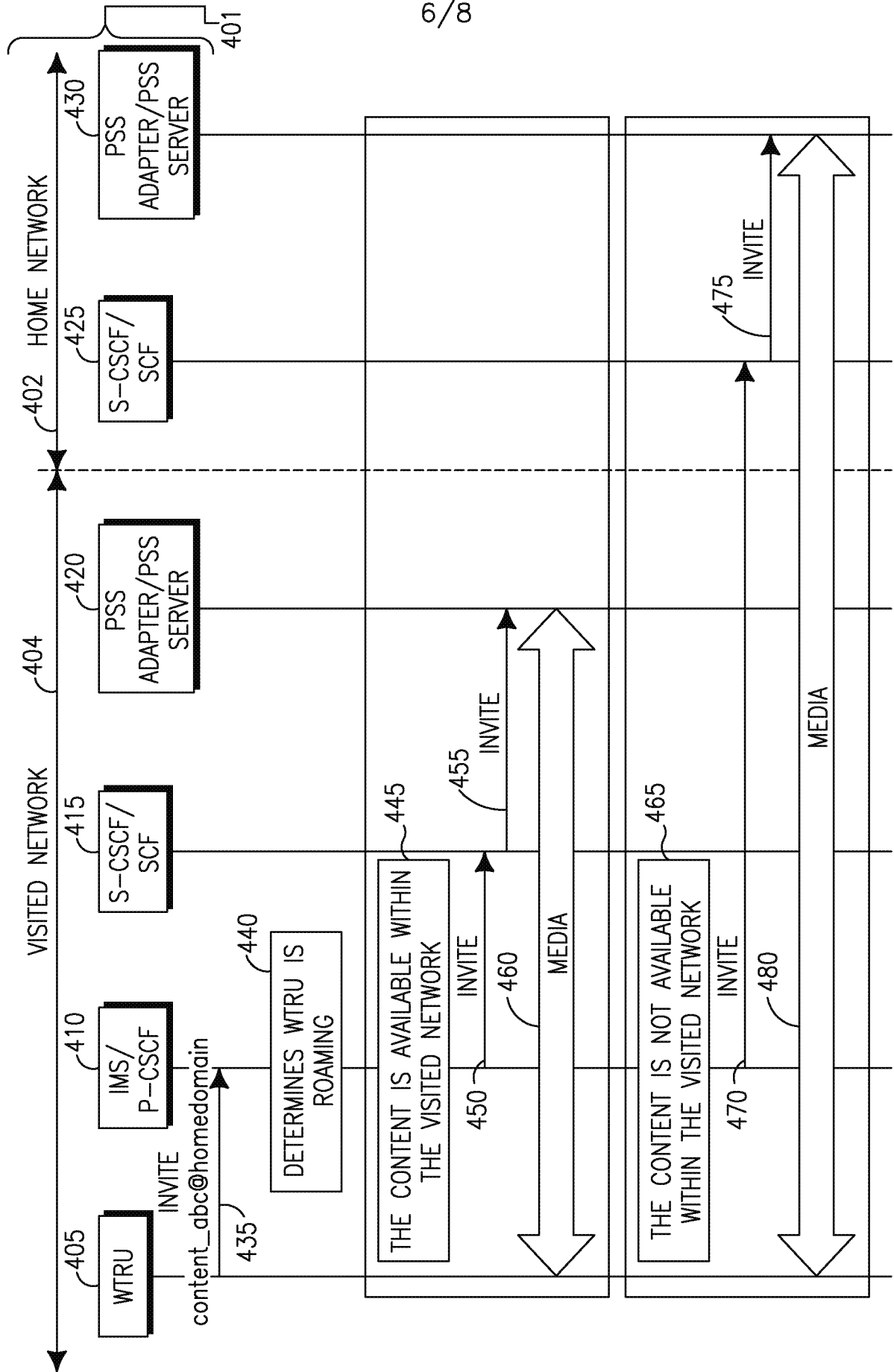

FIG. 4

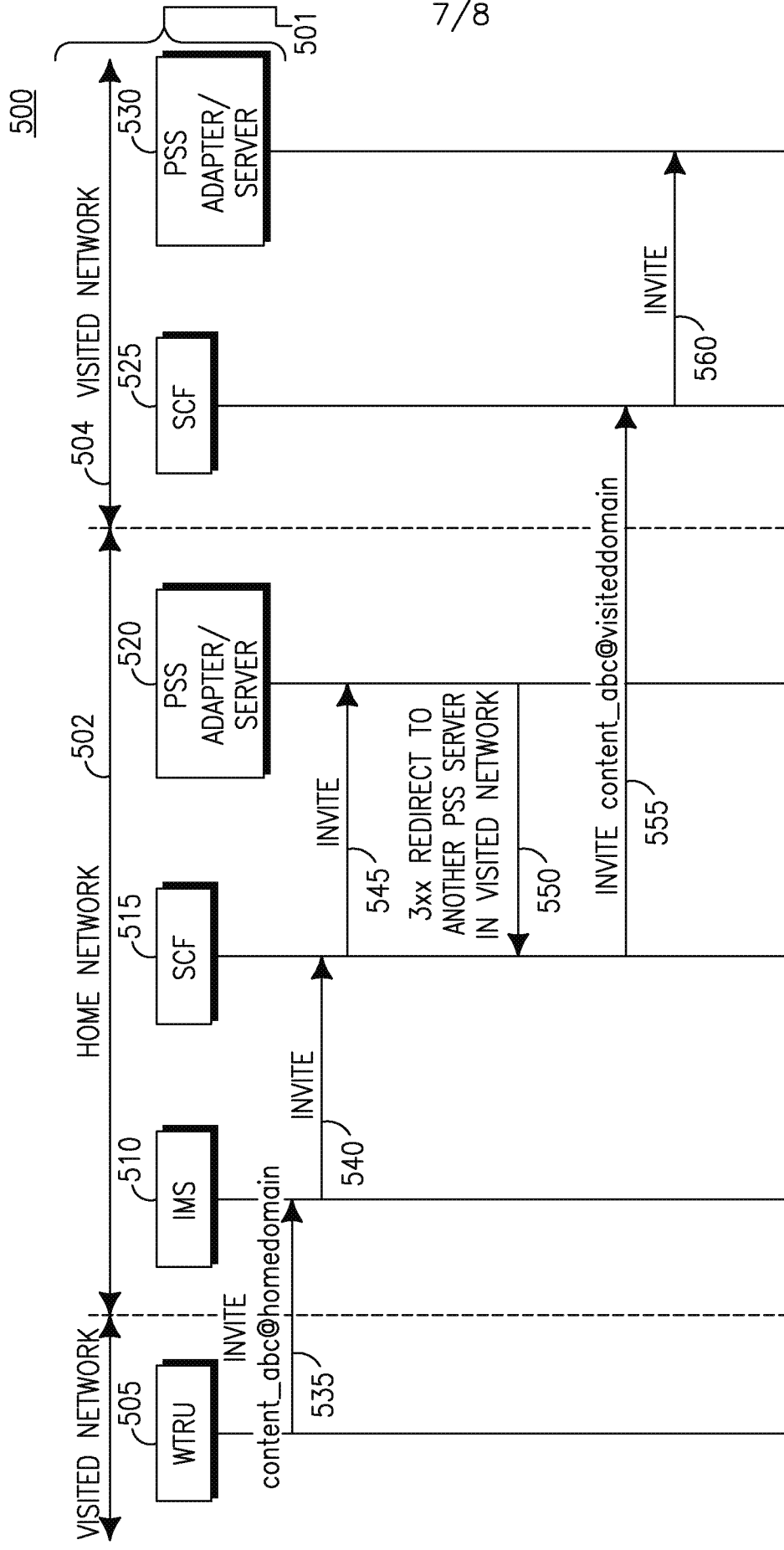

FIG. 5



600

8/8

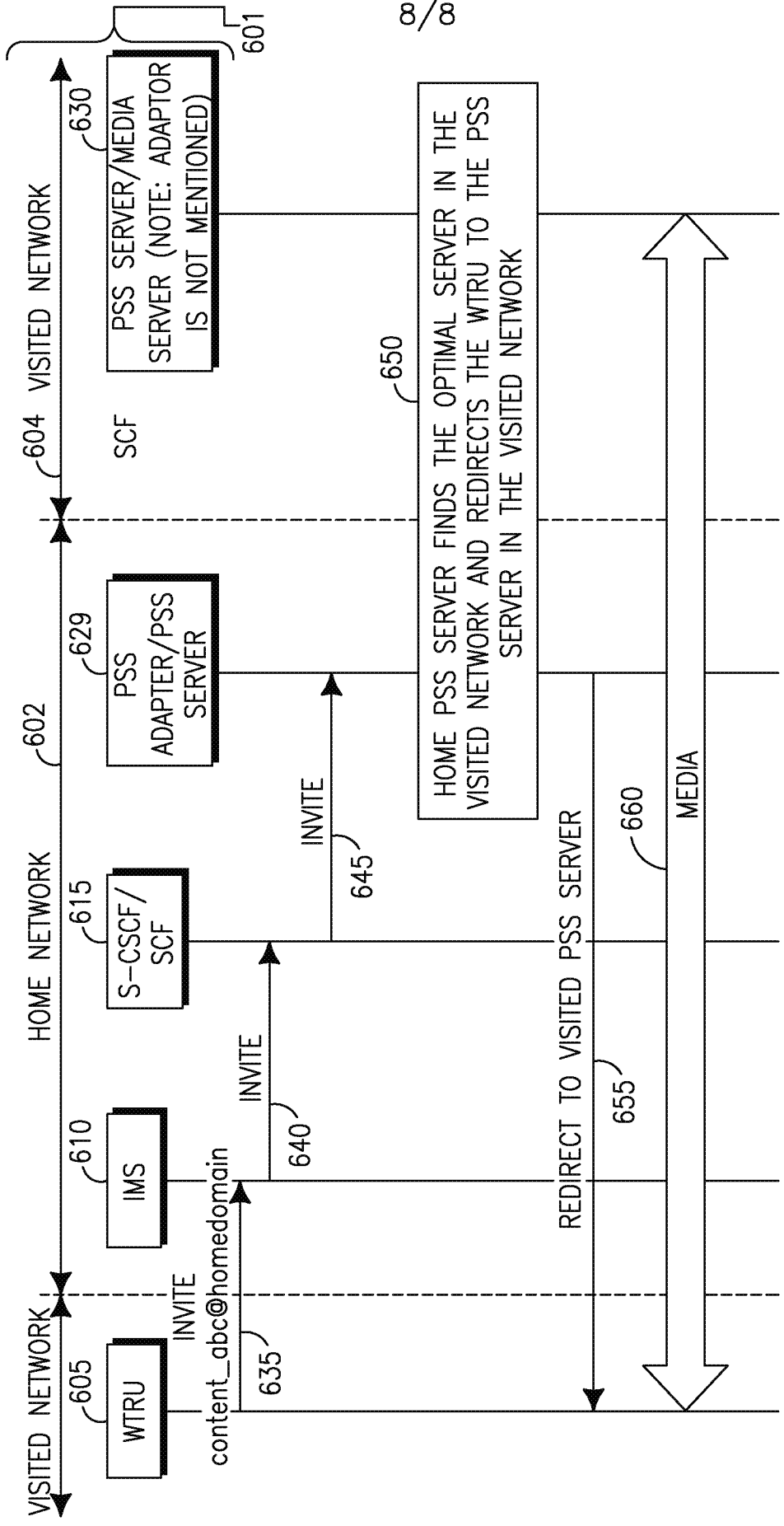

FIG. 6

+

INTERNATIONAL SEARCH REPORT

International application No
PCT/US2012/042630

A. CLASSIFICATION OF SUBJECT MATTER
INV. H04L29/06 H04L29/08
ADD.
According to International Patent Classification (IPC) or to both national classification and IPC

B. FIELDS SEARCHED
Minimum documentation searched (classification system followed by classification symbols)
H04L H04W

Documentation searched other than minimum documentation to the extent that such documents are included in the fields searched

Electronic data base consulted during the international search (name of data base and, where practicable, search terms used)
EPO-Internal, WPI Data

C. DOCUMENTS CONSIDERED TO BE RELEVANT

Category*	Citation of document, with indication, where appropriate, of the relevant passages	Relevant to claim No.
X	EP 1 331 791 A2 (DOCOMO COMM LAB USA INC [US] NTT DOCOMO INC [JP]) 30 July 2003 (2003-07-30) paragraph [0005] - paragraph [0009] paragraph [0047] - paragraph [0053] paragraph [0058] - paragraph [0060] paragraph [0076] - paragraph [0088] paragraph [0097] -----	1-20
X	EP 2 262 199 A1 (HUAWEI TECH CO LTD [CN]) 15 December 2010 (2010-12-15) paragraph [0005] - paragraph [0007] paragraph [0050] - paragraph [0054] paragraph [0123] - paragraph [0135] paragraph [0164] - paragraph [0166] figures 6-8,10 -----	1-20

Further documents are listed in the continuation of Box C.

See patent family annex.

* Special categories of cited documents :

- "A" document defining the general state of the art which is not considered to be of particular relevance
- "E" earlier application or patent but published on or after the international filing date
- "L" document which may throw doubts on priority claim(s) or which is cited to establish the publication date of another citation or other special reason (as specified)
- "O" document referring to an oral disclosure, use, exhibition or other means
- "P" document published prior to the international filing date but later than the priority date claimed

- "T" later document published after the international filing date or priority date and not in conflict with the application but cited to understand the principle or theory underlying the invention
- "X" document of particular relevance; the claimed invention cannot be considered novel or cannot be considered to involve an inventive step when the document is taken alone
- "Y" document of particular relevance; the claimed invention cannot be considered to involve an inventive step when the document is combined with one or more other such documents, such combination being obvious to a person skilled in the art
- "&" document member of the same patent family

Date of the actual completion of the international search
4 October 2012

Date of mailing of the international search report
10/10/2012

Name and mailing address of the ISA/
European Patent Office, P.B. 5818 Patentlaan 2
NL - 2280 HV Rijswijk
Tel. (+31-70) 340-2040,
Fax: (+31-70) 340-3016

Authorized officer
Walker Pina, J

INTERNATIONAL SEARCH REPORT

Information on patent family members

International application No

PCT/US2012/042630

Patent document cited in search report	Publication date	Patent family member(s)	Publication date
EP 1331791	A2	30-07-2003	DE 60319758 T2
			EP 1331791 A2
			JP 2003289327 A
			US 2003145038 A1

EP 2262199	A1	15-12-2010	CN 101547189 A
			EP 2262199 A1
			US 2011023071 A1
			WO 2009117919 A1
