

H. Keeney.

Cheese Curd Cutter.

N^o 49,631.

Patented Aug. 29, 1865.

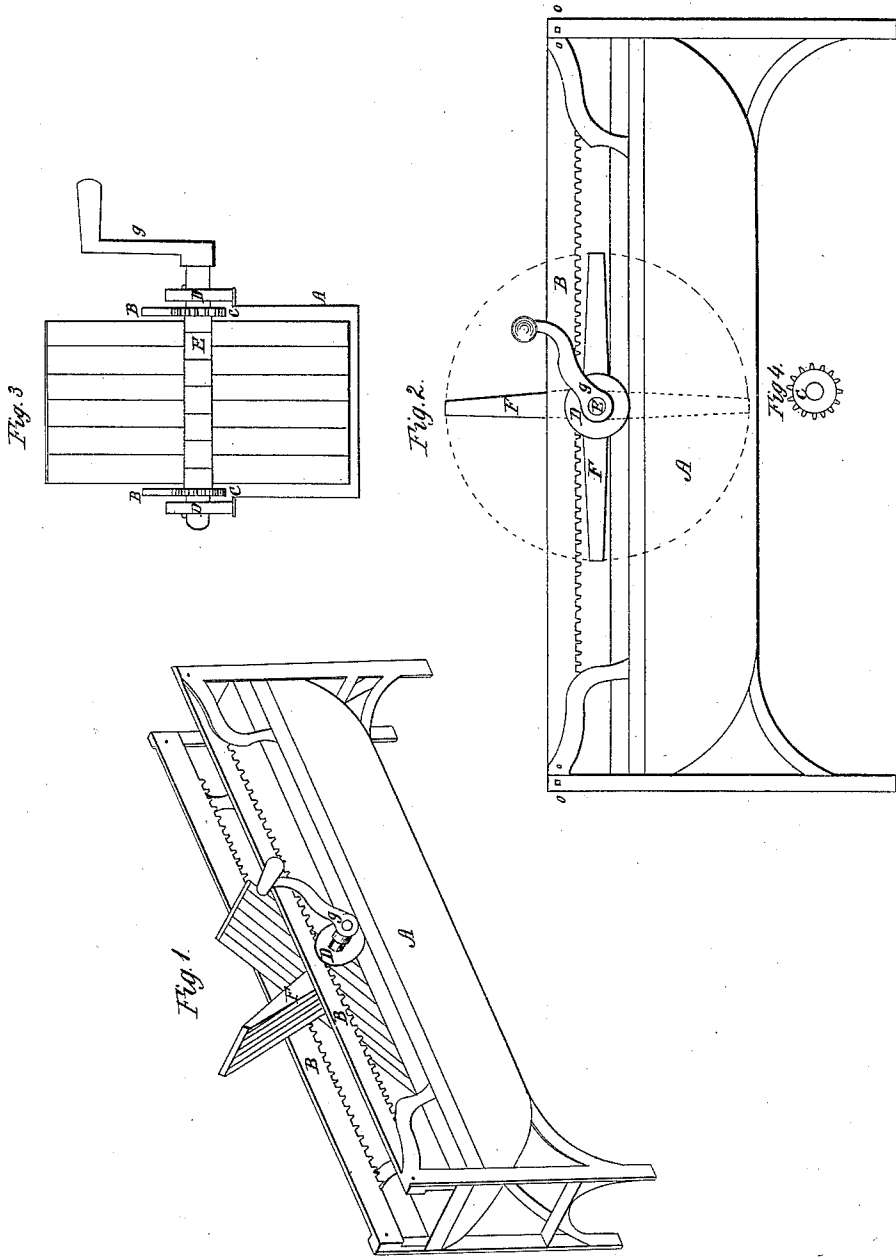

Witnesses:
W. M. Swinton
Ed. A. Gillett

Inventor:
William Keeney

UNITED STATES PATENT OFFICE.

HIRAM KEENEY, OF POTTER CENTRE, NEW YORK.

IMPROVEMENT IN CHEESE-CURD CUTTERS.

Specification forming part of Letters Patent No. 49,631, dated August 29, 1865.

To all whom it may concern:

Be it known that I, HIRAM KEENEY, of Potter Centre, in the county of Yates and State of New York, have invented a new and useful Improvement in Cheese-Curd Cutters; and I do hereby declare that the following is a full, clear, and exact description of the construction and operation of the same, reference being had to the annexed drawings, making a part of this specification, in which—

Figure 1 is a perspective view. Fig. 2 is a side elevation. Fig. 3 is a transverse section. Fig. 4 is a view of pinion C detached.

The letters of reference refer to the same parts in each figure.

The nature of my invention consists in providing cheese-vats with revolving knives for cutting curd. The knives are operated by means of racks and pinions, as hereinafter described.

To enable others skilled in the art to make and use my invention, I will proceed to describe its construction.

I make my cheese-vats of any suitable material, with the ends rounded from the bottom upward, so as to conform to the segment of the circle described by the outer end of the knives, as shown in Fig. 2.

The frame that supports the vat may be made of either wood or metal.

The racks B B, in which the pinions C C work to produce the reciprocating motion, are made adjustable by means of bolts at the ends attached to the frame at *o o*, Fig. 2, so that they and the knives may be removed when desired.

The racks B B are not to be permanently at-

tached to the frame, as represented by the accompanying drawings.

What I wish particularly to describe as part of my invention is the construction and arrangement of the racks B B, pinions C C, and bearing-rollers D D, in connection with the shaft E, on which the revolving knives F F are attached, so that the revolving knives pass through the curd from the bottom of the vat upward in the same direction of the advance motion of the shaft E when turned by crank *g*.

I make my knives of iron or any suitable metal, in four sets, attached to the same shaft, and place them at right angles to each other. Their length must correspond with the depth of vat in which they are used. The number of knives will be governed by the width of the vat, as represented in Figs. 2 and 3.

What I claim as my invention, and desire to secure by Letters Patent, is—

1. The vat A, Figs. 1, 2, and 3, in combination with the racks B B, pinions C C, and rollers D D.

2. So arranging the racks B B, pinions C C, and rollers D D, in combination with shaft E and crank *g*, as to give the knives F F a revolving motion from the bottom of the vat upward through the curd, always in the direction of the advance motion of the shaft E when turned by crank *g*.

3. The revolving knives for the purpose of cutting curds in the process of making cheese, substantially as and for the purpose set forth.

HIRAM KEENEY.

Witnesses:

P. M. HUTTON,

ED. A. GILLET.