

19



LE GOUVERNEMENT
DU GRAND-DUCHÉ DE LUXEMBOURG
Ministère de l'Économie

11

N° de publication :

LU507366

12

BREVET D'INVENTION**B1**

21

N° de dépôt: LU507366

51

Int. Cl.:

G01S 13/91, G01S 7/00, G01S 13/00

22

Date de dépôt: 29/05/2024

30

Priorité:

72

Inventeur(s):

OU Minghui – China

43

Date de mise à disposition du public: 05/12/2024

74

Mandataire(s):

Patent42 SA – 4081 Esch-sur-Alzette (Luxembourg)

47

Date de délivrance: 05/12/2024

73

Titulaire(s):

CHONGQING VOCATIONAL INSTITUTE OF
ENGINEERING – 402260 Chongqing City (China)

54

DEVICE FOR MONITORING VEHICLE DISTANCE OF AUTONOMOUS VEHICLES.

57

The present invention relates to a device for monitoring vehicle distance of autonomous vehicles, including a base plate. A vehicle distance monitoring radar is connected to a top of the base plate in a movable way, two clamping assemblies connected to the vehicle distance monitoring radar is fixedly connected to the top of the base plate in a movable way, and splicing assemblies are arranged at the clamping assemblies. The clamping assemblies are pulled towards two sides, and the clamping assemblies are engaged with the splicing assemblies to cause the splicing assemblies to be separated from the vehicle distance monitoring radar placed on the base plate; and when the vehicle distance monitoring radar is re-mounted, after the vehicle distance monitoring radar is placed on the base plate, the splicing assemblies are pulled, and the clamping assemblies will automatically clamp and fix the vehicle distance monitoring radar.

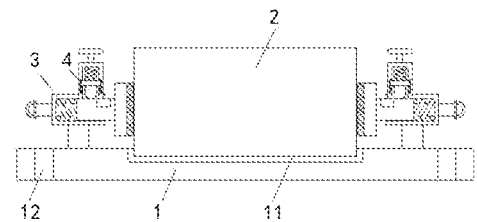

FIG. 1

DESCRIPTION

DEVICE FOR MONITORING VEHICLE DISTANCE OF AUTONOMOUS VEHICLES

TECHNICAL FIELD

The present invention relates to the technical field of vehicle distance monitoring, and in particular to a device for monitoring vehicle distance of autonomous vehicles.

BACKGROUND

Autonomous vehicles, also known as unmanned vehicles, computer-driven vehicles or wheeled mobile robots, are a kind of intelligent vehicles that achieve unmanned driving through computer systems.

It is necessary to use a vehicle distance monitor to monitor the distance to the surrounding vehicles to ensure the safety of driving when an autonomous vehicle is driven. However, most of the vehicle distance monitors available on the current market are inconvenient to disassemble, generally, the bolts are fixed to the vehicle body, and it is troublesome to screw the bolts every time when maintenance is needed. Therefore, a device for monitoring vehicle distance of autonomous vehicles is proposed to solve the above problem.

SUMMARY

In view of the shortcomings of the prior art, the present invention provides a device for monitoring vehicle distance of autonomous vehicles, which has advantages of easy maintenance and solves the problems of fixed structure and inconvenient maintenance.

In order to achieve the above object, the present invention provides the following technical solutions. A device for monitoring vehicle distance of autonomous vehicles includes a base plate.

A vehicle distance monitoring radar is connected to a top of the base plate in a movable way, two clamping assemblies connected to the vehicle distance monitoring radar in a movable way are fixedly connected to the top of the base plate, and splicing assemblies are arranged at the clamping assemblies; and

the clamping assemblies include supporting rods fixedly connected to the top of the base plate, sleeves are fixedly connected to tops of the supporting rods, clamping springs are fixedly connected to inner cavity walls of facing sides of two sleeves, and connecting rods are fixedly connected to facing sides of two clamping springs; and clamping plates connected to the vehicle distance monitoring radar in a movable way are fixedly connected to facing sides of two connecting rods, pull rods penetrating to outer sides of the sleeves are fixedly connected to opposite sides of the two connecting rods, and pull rings are fixedly connected to opposite sides of two pull rods.

Further, a placing groove adapted to the vehicle distance monitoring radar is disposed at the top of the base plate, and two through holes are disposed at the base plate.

Further, the connecting rods are slidingly connected to inner cavity walls of the sleeves, and sides of the connecting rods away from the clamping springs penetrating to outer sides of the sleeves.

Further, non-slip mats are fixedly connected to facing sides of the clamping plates, and the clamping plates are connected to the vehicle distance monitoring radar in a movable way via the non-slip mats.

Further, the splicing assemblies include sleeve shells embedded at tops of the sleeves, splicing springs are fixedly connected to tops of inner cavities of the sleeve shells, sliding blocks slidably connected to inner cavity walls of the sleeve shells are fixedly connected to bottoms of the splicing springs, splicing rods connected to tops of the connecting rods in a movable way are fixedly connected to bottoms of the sliding blocks, driving rods penetrating to tops of outer sides of the sleeve shells are fixedly connected to tops of the sliding blocks, and handles are fixedly connected to tops of the driving rods.

Further, elongated sliding grooves adapted to the sliding blocks are disposed on the inner cavity walls of the sleeve shells, and splicing grooves adapted to the splicing rods are disposed at the tops of the connecting rods.

Compared with the prior art, the present invention has the following advantageous effects.

1. In the device for monitoring vehicle distance of autonomous vehicles, when the vehicle distance monitoring radar needs to be maintained, the clamping assemblies are pulled towards two sides, and the clamping assemblies are engaged with the splicing assemblies to cause the splicing assemblies to be separated from the vehicle distance monitoring radar placed on the base plate. When the vehicle distance monitoring radar is re-mounted, after the vehicle distance monitoring radar is placed on the base plate, the splicing assemblies are pulled, and the clamping assemblies will automatically clamp and fix the vehicle distance monitoring radar. The whole structure is simple, which achieves the object of convenient maintenance of the device for monitoring vehicle distance of autonomous vehicles, and saving time and effort.

2. In the device for monitoring vehicle distance of autonomous vehicles, the base plate can be fixed by bolts penetrating through the through holes of the base plate, the base plate does not need to be disassembled, and the vehicle distance monitoring radar can be locate by the placing groove.

BRIEF DESCRIPTION OF THE DRAWINGS

FIG. 1 is a schematic structural diagram of the present invention;

FIG. 2 is a schematic structural diagram of a clamping assembly of the present invention; and

FIG. 3 is a schematic structural diagram of a splicing assembly of the present invention.

Reference numerals and denotations thereof: 1-base plate; 11-placing groove; 12-through hole; 2-vehicle distance monitoring radar; 3-clamping assembly; 31-supporting rod; 32-sleeve; 33-clamping spring; 34-connecting rod; 35-clamping plate;

36-pull rod; 37-pull ring; 4-splicing assembly; 41-sleeve shell; 42-splicing spring; 43-sliding block; 44-splicing rod; 45-driving rod; and 46-handle.

DETAILED DESCRIPTION

Technical solutions in the examples of the present invention will be described clearly and completely in the following with reference to the attached drawings in the examples of the present invention. Obviously, all the described examples are only some, rather than all examples of the present invention. On the basis of the examples in the present invention, all other examples obtained by those ordinary skill in the art without creative efforts belong to the scope of protection of the present invention.

Referencing to FIG. 1, a device for monitoring vehicle distance of autonomous vehicles in the present example includes a base plate 1. A vehicle distance monitoring radar 2 is connected to a top of the base plate 1 in a movable way, the vehicle distance monitoring radar 2 is a prior art known to the public in the technical field, and the principle and structure of the vehicle distance monitoring radar 2 will not be described in detail; and two clamping assemblies 3 connected to the vehicle distance monitoring radar 2 in a movable way are fixedly connected to the top of the base plate 1, and splicing assemblies 4 are arranged at the clamping assemblies 3.

It is to be noted that a placing groove 11 adapted to the vehicle distance monitoring radar 2 is disposed at the top of the base plate 1, the placing groove 11 is used for assisting a mounting and positioning of the vehicle distance monitoring radar 2, and two through holes 12 are disposed at the base plate 1.

Referencing to FIGS. 2-3, the clamping assemblies 3 in the present example include supporting rods 31 fixedly connected to the top of the base plate 1. Sleeves 32 are fixedly connected to tops of the supporting rods 31, the sleeves 32 are missing pentahedron on a right side; clamping springs 33 are fixedly connected to inner cavity walls of facing sides of two sleeves 32, the vehicle distance monitoring radar 2 is clamped and fixed by the clamping springs 33 by an elastic force given to clamping plates 35 by connecting rods 34, and the connecting rods 34 are fixedly connected to

facing sides of two clamping springs 33, and the clamping plates 35 connected to the vehicle distance monitoring radar 2 in a movable way are fixedly connected to facing sides of two connecting rods 34; and pull rods 36 penetrating to outer sides of the sleeves 32 are fixedly connected to opposite sides of the two connecting rods 34, and pull rings 37 are fixedly connected to opposite sides of two pull rods 36.

In the present example, the pull rods 36 are pulled to drive the connecting rods 34 and the clamping plates 35 to move toward two sides to separated from the vehicle distance monitoring radar 2 until the connecting rods 34 are engaged with splicing rods 44, and the vehicle distance monitoring radar 2 can be easily taken out.

It is to be noted that the connecting rods 34 are slidably connected to inner chamber walls of the sleeves 32, and sides of the connecting rods 34 away from the clamping springs 33 penetrate to the outer sides of the sleeves 32.

It is to be noted that non-slip mats are fixedly connected to facing sides of two clamping plates 35, the non-slip mats are rubber mats, which can increase friction between the clamping plates 35 and the vehicle distance monitoring radar 2, and the clamping plates 35 are connected to the vehicle distance monitoring radar 2 in a movable way via the non-slip mats.

It is to be understood that the splicing assemblies 4 include sleeve shells 41 embedded at tops of the sleeves 32. Splicing springs 42 are fixedly connected to tops of inner cavities of the sleeve shells 41, sliding blocks 43 slidably connected to inner cavity walls of the sleeve shells 41 are fixedly connected to bottoms of the splicing springs 42, and the splicing rods 44 connected to tops of the connecting rods 34 in a movable way are fixedly connected to bottoms of the sliding blocks 43; and driving rods 45 penetrating to tops of outer sides of the sleeve shells 41 are fixedly connected to tops of the sliding blocks 43, and handles 46 are fixedly connected to tops of the driving rods 45. When the pull rings 37 are pulled, with movements of the connecting rods 34, the splicing rods 44 slide on outer surfaces of the connecting rods 34 until splicing grooves on the connecting rods 34 move below the splicing rods 44, and the splicing rods 44 penetrate through inner cavities of the splicing grooves under the action of the splicing springs 42, and form a clamping state with the connecting rods to keep whole clamping assemblies 3 fixed.

Elongated sliding grooves adapted to the sliding blocks 43 are disposed on the inner cavity walls of the sleeve shells 41, and the splicing grooves adapted to the splicing rods 44 are disposed at the tops of the connecting rods 34.

Working principles of the above examples are as follows.

When the vehicle distance monitoring radar 2 needs to be maintained, the pull rings 37 are pulled, the connecting rods 34 are driven by the pull rods 36 to slide in the sleeves 32, and the clamping springs 33 are compressed until the splicing rods 44 are engaged with the connecting rods 34 under the action of the splicing springs 42 in a compressed state and fixed; the clamping plates 35 move along with the connecting rods 34 towards two sides and are separated from the vehicle distance monitoring radar 2, and the vehicle distance monitoring radar 2 can be taken out to perform clearance; when mounted, the vehicle distance monitoring radar 2 is placed in the placing groove 11 on the base plate 1, the handles 46 are pulled, and the splicing rods 44 are driven by the sliding blocks 43 to rise and separate from the connecting rods 34; and after the clamping rods 44 are disengaged from the connecting rods 34, the clamping plates 35 move towards a middle under the action of the clamping springs 33, and the vehicle distance monitoring radar 2 is clamped and fixed, thus achieving an object of convenient maintenance of the device for monitoring vehicle distance of autonomous vehicles, and saving time and effort.

It is to be noted that in the present invention, relational terms such as first and second, and the like, may be used herein to distinguish one entity or action from another entity or action without necessarily requiring or implying any actual such relationship or order between such entities or actions. Furthermore, the terms "including", "comprising", or any other variations thereof, are intended to cover non-exclusive inclusion, so that a process, method, article, or apparatus including a series of elements includes not only those elements, but also other elements not explicitly listed, or elements inherent to such process, method, article, or apparatus. Without further restrictions, an element defined by the phrase "including one....." does not exclude the existence of other identical elements in the process, method, article or apparatus that includes the elements.

While examples of the present invention have been illustrated and described, those ordinary skilled in the art will understand that various changes, modifications, substitutions and variations can be made to these examples without departing from the principles and spirit of the present invention. The scope of the present invention is limited to the appended claims and equivalents thereof.

CLAIMS

1. A device for monitoring vehicle distance of autonomous vehicles, comprising a base plate (1), wherein a vehicle distance monitoring radar (2) is connected to a top of the base plate (1) in a movable way, two clamping assemblies (3) connected to the vehicle distance monitoring radar (2) in a movable way are fixedly connected to the top of the base plate (1), and splicing assemblies (4) are arranged at the clamping assemblies (3); and

the clamping assemblies (3) comprise supporting rods (31) fixedly connected to the top of the base plate (1), sleeves (32) are fixedly connected to tops of the supporting rods (31), clamping springs (33) are fixedly connected to inner cavity walls of facing sides of two sleeves (32), and connecting rods (34) are fixedly connected to facing sides of two clamping springs (33); and clamping plates (35) connected to the vehicle distance monitoring radar (2) in a movable way are fixedly connected to facing sides of two connecting rods (34), pull rods (36) penetrating to outer sides of the sleeves (32) are fixedly connected to opposite sides of the two connecting rods (34), and pull rings (37) are fixedly connected to opposite sides of two pull rods (36).

2. The device for monitoring vehicle distance of autonomous vehicles according to claim 1, wherein a placing groove (11) adapted to the vehicle distance monitoring radar (2) is disposed at the top of the base plate (1), and two through holes (12) are disposed at the base plate (1).

3. The device for monitoring vehicle distance of autonomous vehicles according to claim 1, wherein the connecting rods (34) are slidably connected to inner cavity walls of the sleeves (32), and sides of the connecting rods (34) away from the clamping springs (33) penetrates to the outer sides of the sleeves (32).

4. The device for monitoring vehicle distance of autonomous vehicles according to claim 1, wherein non-slip mats are fixedly connected to facing sides of the clamping plates (35), and the clamping plates (35) are connected to the vehicle distance monitoring radar (2) in a movable way via the non-slip mats.

5. The device for monitoring vehicle distance of autonomous vehicles according to claim 1, wherein the splicing assemblies (4) comprise sleeve shells (41) embedded at tops of the sleeves (32), splicing springs (42) are fixedly connected to tops of inner cavities of the sleeve shells (41), sliding blocks (43) slidably connected to inner cavity walls of the sleeve shells (41) are fixedly connected to bottoms of the splicing springs (42), splicing rods (44) connected to tops of the connecting rods (34) in a movable way are fixedly connected to bottoms of the sliding blocks (43), driving rods (45) penetrating to tops of outer sides of the sleeve shells (41) are fixedly connected to tops of the sliding blocks (43), and handles (46) are fixedly connected to tops of the driving rods (45).

6. The device for monitoring vehicle distance of autonomous vehicles according to claim 5, wherein elongated sliding grooves adapted to the sliding blocks (43) are disposed on the inner cavity walls of the sleeve shells (41), and splicing grooves adapted to the splicing rods (44) are disposed at the tops of the connecting rods (34).

REVENDEICATIONS

1. Dispositif de contrôle de la distance des véhicules autonomes, comprenant une plaque de base (1), dans laquelle un radar de contrôle de la distance des véhicules (2) est connecté à un sommet de la plaque de base (1) de manière mobile, deux ensembles de serrage (3) connectés au radar de contrôle de la distance des véhicules (2) de manière mobile sont connectés de manière fixe au sommet de la plaque de base (1), et des ensembles d'épissure (4) sont disposés sur les ensembles de serrage (3) ; et

les ensembles de serrage (3) comprennent des tiges de support (31) reliées de manière fixe au sommet de la plaque de base (1), des manchons (32) reliés de manière fixe aux sommets des tiges de support (31), des ressorts de serrage (33) reliés de manière fixe aux parois de la cavité intérieure des côtés opposés de deux manchons (32), et des tiges de connexion (34) reliées de manière fixe aux côtés opposés de deux ressorts de serrage (33) ; et des plaques de serrage (35) reliées au radar de surveillance de la distance du véhicule (2) de manière mobile sont reliées de manière fixe aux côtés opposés de deux bielles (34), des tiges de traction (36) pénétrant dans les côtés extérieurs des manchons (32) sont reliées de manière fixe aux côtés opposés des deux bielles (34), et des anneaux de traction (37) sont reliés de manière fixe aux côtés opposés de deux tiges de traction (36).

2. Dispositif de contrôle de la distance des véhicules autonomes selon la revendication 1, dans lequel une rainure de placement (11) adaptée au radar de contrôle de la distance du véhicule (2) est disposée au sommet de la plaque de base (1), et deux trous de passage (12) sont disposés sur la plaque de base (1).

3. Dispositif de surveillance de la distance des véhicules autonomes selon la revendication 1, dans lequel les tiges de connexion (34) sont reliées de manière coulissante aux parois de la cavité intérieure des manchons (32), et les côtés des tiges de connexion (34) éloignés des ressorts de serrage (33) pénètrent dans les côtés extérieurs des manchons (32).

4. Dispositif de surveillance de la distance des véhicules autonomes selon la revendication 1, dans lequel des tapis antidérapants sont reliés de manière fixe aux côtés opposés des plaques de serrage (35), et les plaques de serrage (35) sont reliées au radar de surveillance de la distance des véhicules (2) de manière mobile par l'intermédiaire des tapis antidérapants. ^{LU507366}

5. Dispositif de surveillance de la distance des véhicules autonomes selon la revendication 1, dans lequel les ensembles d'épissure (4) comprennent des coquilles de manchon (41) encastrées dans les sommets des manchons (32), des ressorts d'épissure (42) sont reliés de manière fixe aux sommets des cavités intérieures des coquilles de manchon (41), des blocs coulissants (43) reliés de manière coulissante aux parois des cavités intérieures des coquilles de manchon (41) sont reliés de manière fixe aux sommets des ressorts d'épissure (42), les tiges d'épissage (44) reliées de manière mobile aux sommets des bielles (34) sont reliées de manière fixe aux fonds des blocs coulissants (43), les tiges d'entraînement (45) pénétrant dans les sommets des côtés extérieurs des manchons (41) sont reliées de manière fixe aux sommets des blocs coulissants (43), et les poignées (46) sont reliées de manière fixe aux sommets des tiges d'entraînement (45).

6. Dispositif de contrôle de la distance des véhicules autonomes selon la revendication 5, dans lequel des rainures de glissement allongées adaptées aux blocs de glissement (43) sont disposées sur les parois de la cavité intérieure des manchons (41), et des rainures d'épissure adaptées aux tiges d'épissure (44) sont disposées sur les sommets des bielles (34).

FIGURES

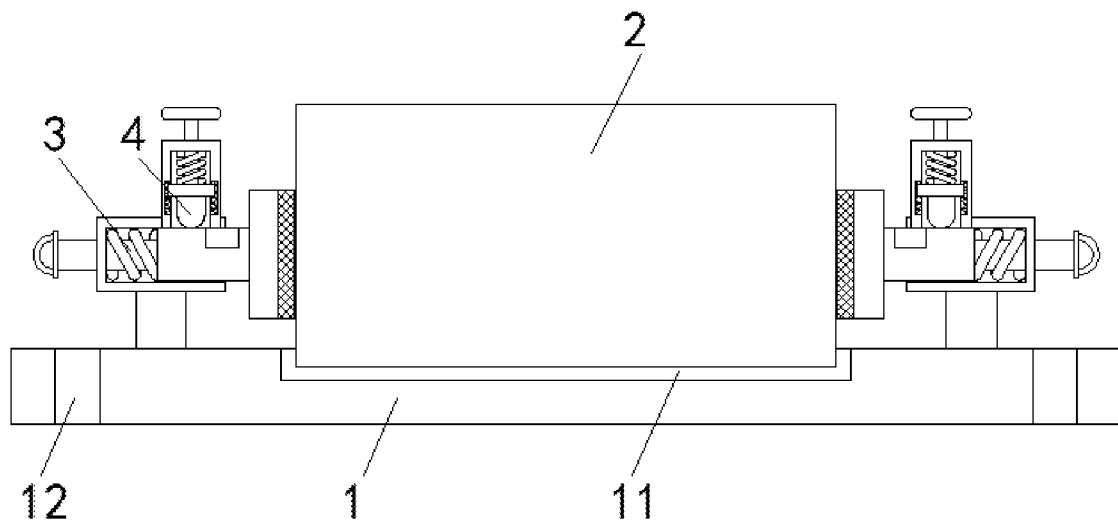

FIG. 1

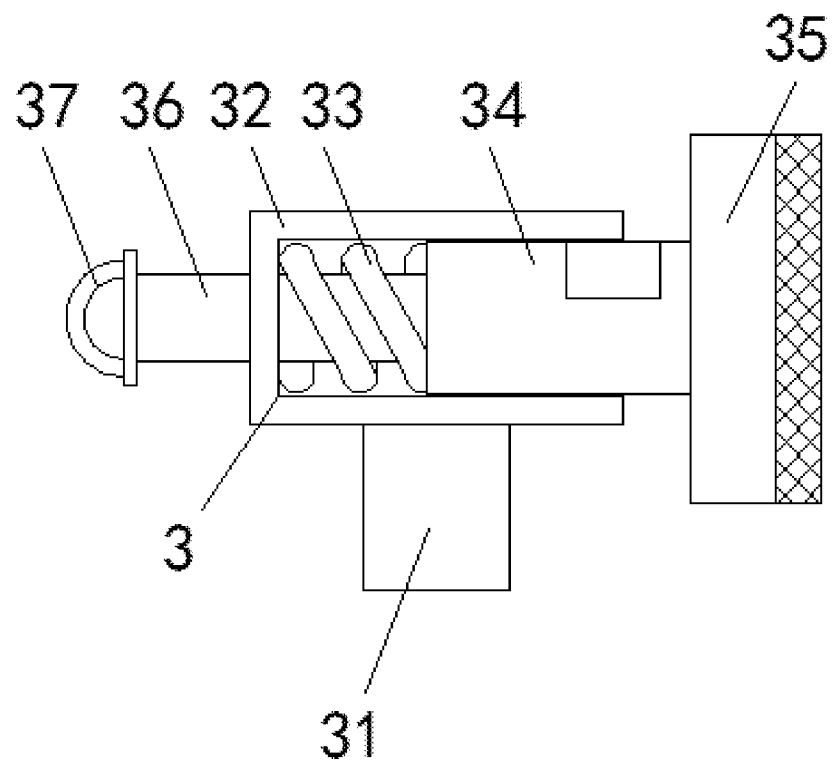

FIG. 2

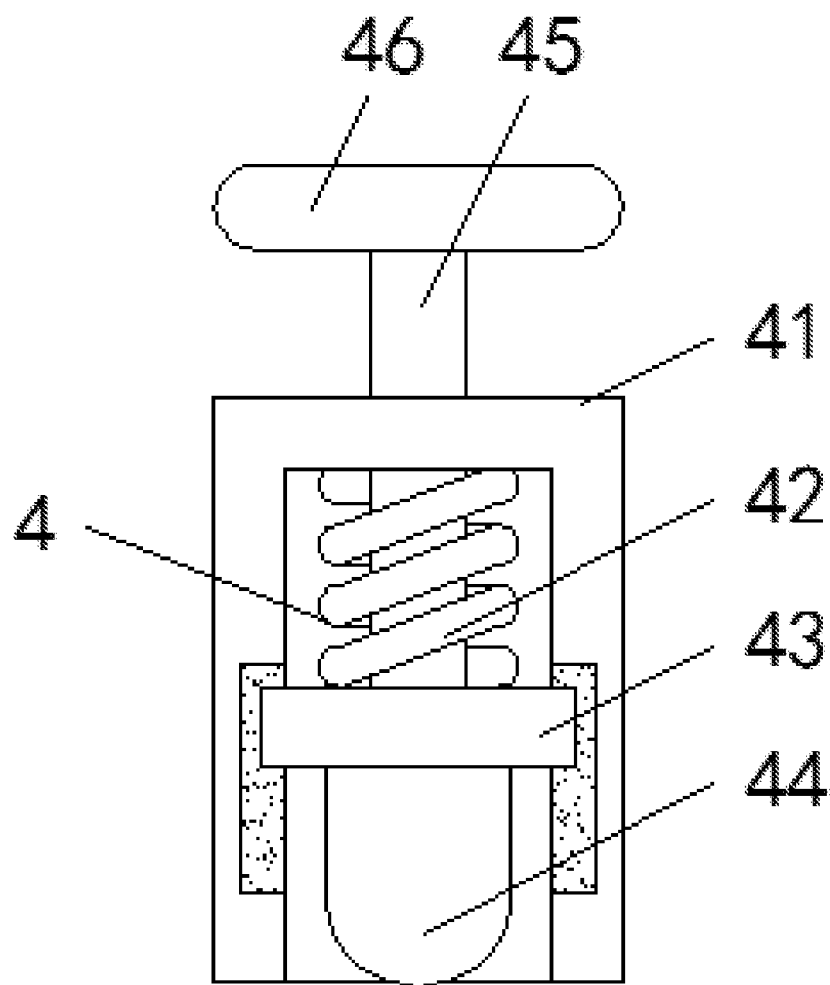

FIG. 3