

R. EMERSON.

Improvement in Machinery for Making Clothes-Pins.

No. 129,118.

Patented July 16, 1872.

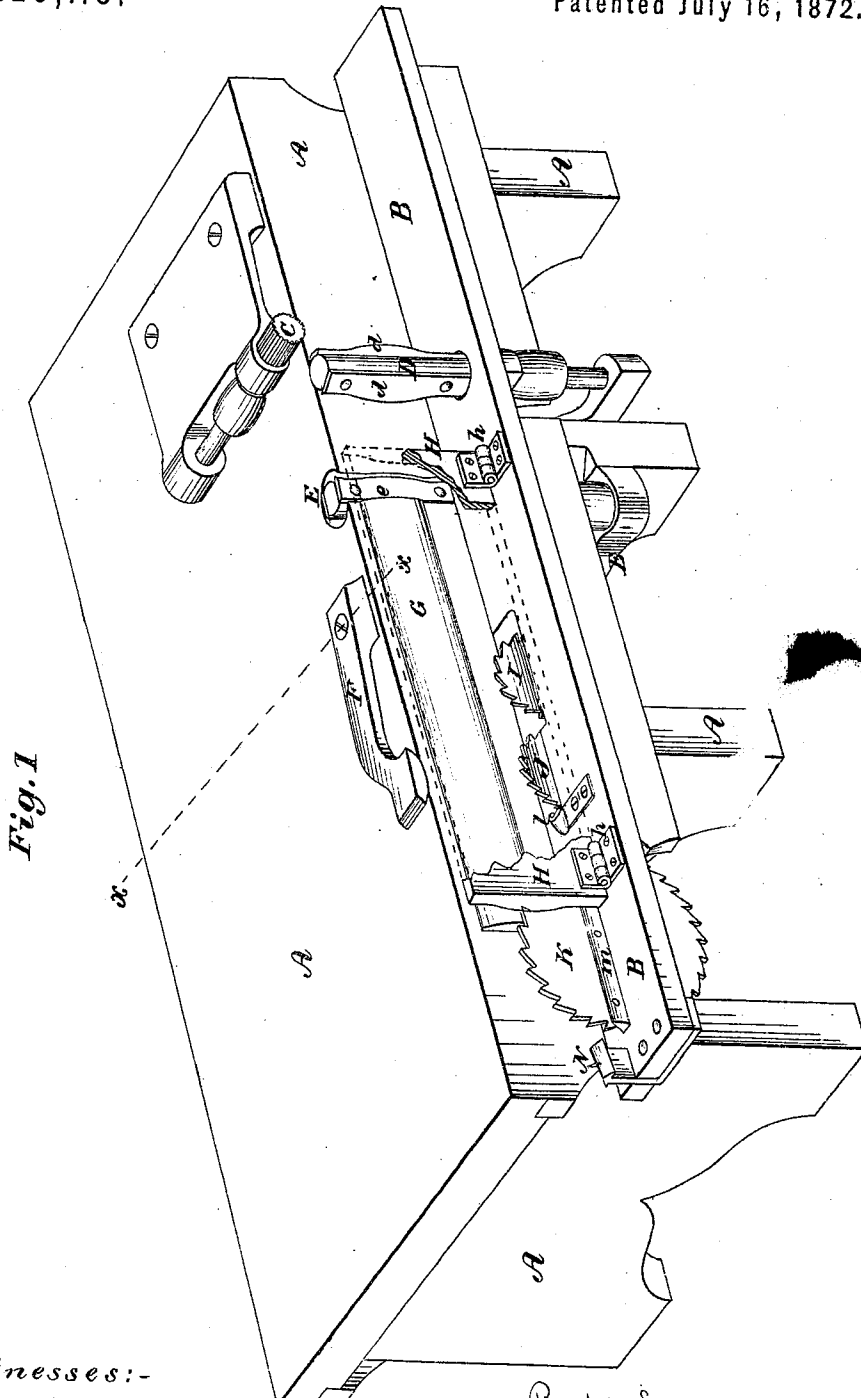

Fig. 1

Witnesses:-  
 W. H. Rowe  
 Edward C. Davidson

Ralph Emerson  
 Inventor:- by his atty  
 Wm. S. Baldwin

R. EMERSON.

Improvement in Machinery for Making Clothes-Pins.

No. 129,118.

Patented July 16, 1872.

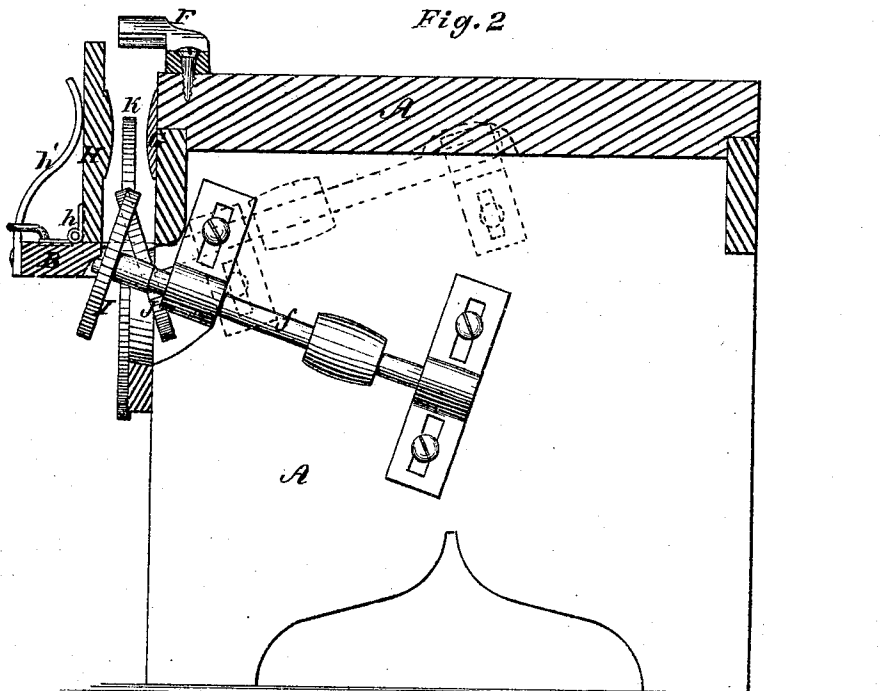
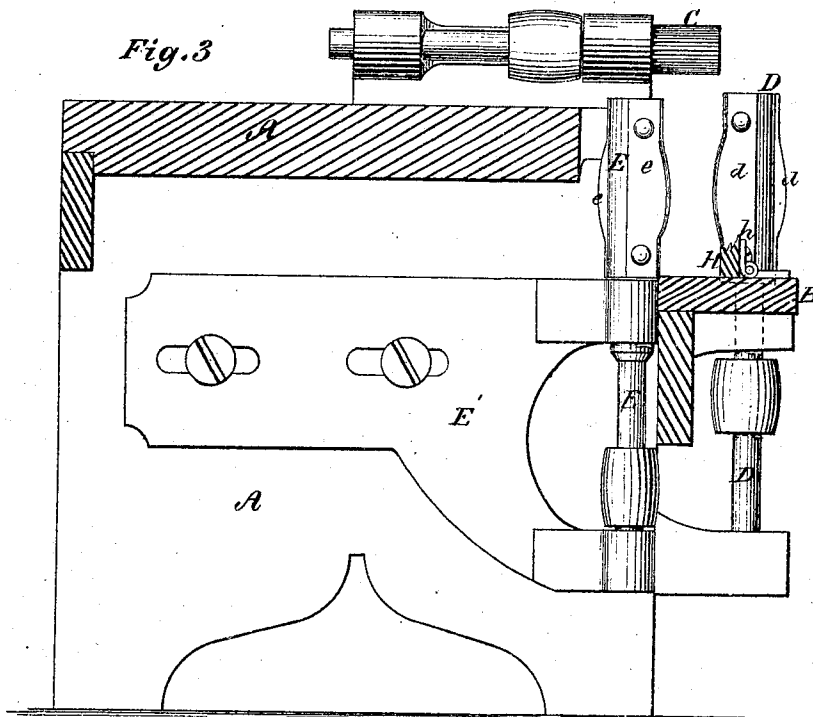

Fig. 2

Fig. 4



Fig. 3



Witnesses:- *W. H. Rowe,*  
*Edw. Davidson*

Inventor:- *Ralph Emerson*  
*by his Atty*  
*Wm. S. Baldwin*

# UNITED STATES PATENT OFFICE.

RALPH EMERSON, OF ROCKFORD, ILLINOIS.

## IMPROVEMENT IN MACHINERY FOR MAKING CLOTHES-PINS.

Specification forming part of Letters Patent No. 129,118, dated July 16, 1872.

*To all whom it may concern:*

Be it known that I, RALPH EMERSON, of Rockford, Illinois, have invented certain new and useful Improvements in Machinery for Manufacturing Clothes-Pins, of which the following is a specification:

The object of my invention is to provide a machine by which to make clothes-pins—such as those shown in an application for Letters Patent filed March 18, 1872. The subject-matter claimed is hereinafter specified.

In the accompanying drawing of my improved machine, Figure 1 is a perspective view; Fig. 2, a transverse section on the line  $xx$  of Fig. 1, looking toward the same; Fig. 3, a similar view, looking the other way; Fig. 4, a view of one of my improved pins.

The mechanism is mounted on a stout frame, A, provided with a shelf, B, upon which the blank from which the pin is formed is held while being worked into shape. This blank consists of a strip, of a proper height and thickness, is fed horizontally past suitable cutters and saws to give the desired shape to the blank, and is then formed into pins by sawing the blank transversely into sections of proper size. A milled feed-roller, C, of ordinary construction is mounted in bearings in an elastic bracket on the frame, and driven in any proper well-known way. This roller overhangs the edge of the table and serves both to feed and to hold down the blank. Cutters or planer-heads  $d$ , of proper outline to give the required shape to the legs of the pin, are fixed on a vertical arbor, D, mounted in a bracket adjustable horizontally and transversely to the line of feed. These cutters shape the outer side of the blank. Similar cutters on an arbor, E, shape the inner side of the blank. This arbor turns in bearings in a bracket, E', made adjustable horizontally by means of slots and screws, as in Fig. 3. The cutters  $e$  revolve in a recess in the side of the table, projecting only enough to do their work. A spring, F, serves to hold down the blank against the upward pressure of the saws, hereinafter described. A fixed guide, G, the counterpart of the outline given to the inner side of the blank, serves to support it while being sawed. An outer guide or presser-leaf, H, of similar form, is hinged at  $h$  to the shelf B, so as to swing down out of the way

when access to the saw is desired. A spring,  $h'$ , keeps this guide up to its work. A buzz-saw, I, is fixed on an arbor,  $f$ , arranged transversely and inclined obliquely to the line of feed, so that the saw makes an inclined cut in the blank parallel to its line of feed. This saw is rendered adjustable in its bearings by means of slots and set-screws, as in Fig. 2, or in other equivalent well-known ways. This adjustment may be used not only to compensate for the wear of the saws, to keep them in their true relation, but may also be used to vary the angle of the cut. A second buzz-saw, J, is in like manner mounted upon the frame behind the other, but with its axis intersecting that of the other at an acute angle. A circular saw, K, of a diameter larger than that of the buzz-saws, is mounted in proper bearings on the frame behind the others in such a manner as to make a vertical cut into the blank parallel to its line of feed. Proper adjustments, both vertical and horizontal, may be given to this saw by well-known means. A clearing-spud,  $l$ , placed between the buzz-saws and the circular saw, clears the chips from the saws and forces them down through a hole in the shelf. Inclined strips  $m$  on each side of the saw K serve to hold the severed sides of the blank steady while the circular saw is making its cut, and prevent them from choking the saw by crowding against it. A burring-knife, N, behind the saw K, smooths any rough edges left in cutting the blank.

The operation of my machine is as follows: A blank of a suitable length, and of a height and thickness to correspond with the size of the finished pin, is placed in the machine with its lower edge resting on the shelf and its upper edge beneath the feed-roller. It is then fed along past the cutters on the arbor, and has its outer side dished, as hereinbefore described, and is then pressed by the hinged leaf against the inner cutters, which cut the opposite side of the blank in a corresponding manner. The blank then passes to the first buzz-saw, which makes an oblique cut, 1 2, Fig. 4, in its bottom, extending inward from one edge past the center line of the block. The second buzz-saw then makes a similar cut, 3 4, intersecting the first one. The sawdust and chips made by these cuts is cleared away by

the spud *l* and conducted beneath the table. The blank then passes over the circular saw, which makes a central longitudinal cut, 5 6, passing through the two oblique cuts at their point of intersection. The burring-knife then removes any burr that is left by the saw, and smoothes the surface of the slot so formed. The jaws and legs of the pin are formed by the three cuts above described, the triangular space 5 being the part which clasps the line. The blank is then sawed up into pieces of suitable thickness, thus making the pin in a very simple, cheap, and expeditious manner.

I claim as my invention—

1. The combination of rotating planer-heads to dress the sides of the blank, guides curved in conformity with the outline of the blank

fed between them, and saws cutting obliquely into the blank, but parallel with its line of movement; all these members being constructed to operate in combination, substantially as set forth.

2. The combination of the inclined saws and clearing-spud, as set forth.

3. The combination of the vertical saw and the leg-guides, as set forth.

4. The combination of the saws and the burring-knife, as set forth.

In testimony whereof I have hereunto subscribed my name.

RALPH EMERSON.

Witnesses:

CLARA GOODALL,

WILLIAM A. TALCOTT.