

(19) **DANMARK**



Patent- og
Varemærkestyrelsen

(10) **DK/EP 3973817 T3**

(12) **Oversættelse af
europæisk patentskrift**

-
- (51) Int.Cl.: **A 47 B 9/10 (2006.01)** **A 47 B 9/02 (2006.01)** **A 47 B 9/12 (2006.01)**
A 47 B 9/20 (2006.01)
- (45) Oversættelsen bekendtgjort den: **2024-05-21**
- (80) Dato for Den Europæiske Patentmyndigheds bekendtgørelse om meddelelse af patentet: **2024-04-24**
- (86) Europæisk ansøgning nr.: **21175115.1**
- (86) Europæisk indleveringsdag: **2021-05-20**
- (87) Den europæiske ansøgnings publiceringsdag: **2022-03-30**
- (30) Prioritet: **2020-09-23 DE 102020211930**
- (84) Designerede stater: **AL AT BE BG CH CY CZ DE DK EE ES FI FR GB GR HR HU IE IS IT LI LT LU LV MC MK MT NL NO PL PT RO RS SE SI SK SM TR**
- (73) Patenthaver: **Kesseböhmer Holding KG, Mindener Straße 208, 49152 Bad Essen, Tyskland**
- (72) Opfinder: **STIEFELMAIER, Philipp, , 73235 Weilheim, Tyskland**
KÖDER, Michael, , 73207 Plochingen, Tyskland
- (74) Fuldmægtig i Danmark: **NORDIC PATENT SERVICE A/S, Bredgade 30, 1260 København K, Danmark**
- (54) Benævnelse: **STØTTEENHED TIL EN HØJDEJUSTERBAR BORDDRAMME**
- (56) Fremdragne publikationer:
EP-A2- 0 963 717
EP-B1- 1 987 734
EP-B1- 2 213 198
WO-A1-2008/145399
US-A1- 2015 047 538

Supporting device for a height-adjustable table frame

The invention relates to a supporting device for a height-adjustable table, in particular for a height-adjustable table having several supporting elements.

5

In the prior art, height-adjustable tables are known which, in order to be able to safely and reliably carry and lift loads which are placed on a table top of the height-adjustable table, have several height-adjustable table legs, which subsequently are also referred to as supporting elements.

10

Thereby, there is the problem that, when the table legs do not move synchronously, components of the height-adjustable table legs can tilt and thus jam.

15

Further, there are two standards for desks in which a minimum adjustable height of the working surface and a required stroke differ. The greater of the requirements of the two standards cannot be fulfilled with 2-part lifting columns, in particular, with installed gas compression springs, since the required minimum adjustable height of the working surface is smaller than the required installation dimension for a gas spring with the required minimum stroke.

20

For this purpose, documents EP 09 63 717 A2, US 2015/0047538 A1, and EP 2 213 198 B1 each disclose a known height-adjustable table system.

25

Document WO 2008/145399 A1 discloses a height-adjustable column, in particular, for tables, which has three extension components. A first extension component, a second extension component, and a third extension component are coupled to one another such that, upon a change in length of the column, a displacement of the second extension component relative to the first extension component in a direction parallel to the change in length synchronously causes a displacement of the third extension component relative to the second extension component in the same direction.

30

Document EP 1 987 734 B1 shows a synchronization device having a rope-like synchronization element, which is fastened at one end to one of the extension components of a first supporting element and is fastened at the other end to the same extension component of a

second supporting element, and having two deflection rollers, which are respectively fastened to another one of the extension components of the first support element and of the second support element, wherein a deflection of the rope-like synchronization element is effected by means of the deflection rollers in such a way that a first relative displacement between the extension components of the first support element results in a synchronous relative displacement between the two extension components of the second support element.

The invention is based on the object of overcoming the above problems and of providing a supporting device for a height-adjustable table which, over an entire adjustment range for an ergonomic working height of the table top, enables a reliable functioning of the height-adjustable table.

The object is achieved by a supporting device according to claim 1 and a height-adjustable table according to claim 12. Advantageous further developments of the invention are included in the dependent claims.

According to an aspect of the invention, a supporting device for a height-adjustable table comprises a first supporting element and at least one second supporting element, wherein the first supporting element and the at least one second supporting element each comprise a first extension component, a second extension component, and a third extension component. The first extension component, the second extension component, and the third extension component are arranged displaceably relative to one another in order to respectively cause a change in length of the first supporting element and of the at least one second supporting element. The second extension component is arranged in a direction of the change in length between the first extension component and the third extension component, and the first extension component, the second extension component, and the third extension component are coupled to one another such that, upon the change in length of the first supporting element and of the at least one second supporting element, a displacement of the second extension component relative to the first extension component in a direction parallel to the change in length synchronously causes a displacement of the third extension component relative to the second extension component in the same direction. The supporting device further comprises a synchronization device which is configured to synchronize, between the first supporting element and the at least one second supporting element, the displacement of the second extension component relative to the first

extension component or the displacement of the third extension component relative to the second extension component.

5 By means of the defined movement of the individual extension components relative to one another, it is enabled that bending moments applied to the supporting elements which arise, for example, as a result of resting on the edge of a table top during a height adjustment or as a result of relatively large eccentrically placed loads on the table top can be offset without excessively loading guides or sliding pieces which are intended to enable the extension components to be moved into one another as backlash-free as possible. This defined movement
10 is correspondingly carried out in a synchronized manner so that tilting of the several supporting elements cannot occur.

In an advantageous embodiment of the supporting device, an extent of the displacement between the second extension component and the first extension component and an extent of
15 the displacement between the third extension component and the second extension component are identical.

By means of the identical displacement extents between the second extension component and the first extension component and between the third extension component and the second
20 extension component, the loading on the guides or sliding pieces can be minimised.

In a further advantageous implementation of the supporting device, the supporting device comprises an endless rope-like element and two third deflection rollers which are arranged spaced apart in the direction of the change in length of the first supporting element and of the at
25 least one second supporting element and are connected to the second extension component, wherein the endless rope-like element is configured such that it is deflected without backlash by the two third deflection rollers and a respective portion of the endless rope-like element is connected to the first extension component and the third extension component in the direction of the change in length of the first supporting element and of the at least one second supporting
30 element between the two third deflection rollers.

By means of this arrangement, in particular, the identical displacement extents between the second extension component and the first extension component and between the third extension component and the second extension component can be easily executed.

According to a further advantageous implementation of the supporting device, the rope-like element is a steel band.

5 By using the steel band with a high tensile strength, the design with a small diameter is possible, which also enables the use of deflection rollers with small dimensions so that installation space can be saved. In addition, due to a small elongation of the steel band, a precisely defined movement of the individual extension components relative to one another is possible.

10

In a further advantageous implementation of the supporting device, the third deflection rollers have a convexity on their running surface along their axis of rotation.

15 Due to the convexity, namely a bulge of the running surface towards the centre of the running surface, self-centring takes place during the running of the steel band so that reliable operation is possible without additional centring devices.

20 According to the invention, the synchronization device has a first rope-like synchronization element which is fastened at one end to one of the extension components of the first supporting element and is fastened at the other end to the same of the extension components of the at least second supporting element and first deflection rollers which are respectively fastened to another one of the extension components of the first supporting element and of the at least second supporting element, wherein the other one of the extension components of the first supporting element and of the at least one second supporting element is respectively the same
25 extension component, and a deflection of the first rope-like synchronization element is effected by means of the first deflection rollers in such a way that a first relative displacement between two of the extension components of the first supporting element results in a synchronous relative displacement between the two same extension components of the at least one second supporting element.

30

By means of this arrangement, the relative displacement between two identical extension components amongst the two supporting elements can be easily executed.

According to a further advantageous implementation of the supporting device, the synchronization device has a second rope-like synchronization element which is fastened at one end to one of the extension components of the first supporting element and is fastened at the other end to the same of the extension components of the at least second supporting element and second deflection rollers which are respectively fastened to the other one of the extension components of the first supporting element and of the at least second supporting element, wherein the other one of the extension components of the first supporting element and of the at least one second supporting element is respectively the same extension component. A deflection of the second rope-like synchronization element is effected by means of the second deflection rollers in such a way that an opposite relative displacement between two of the extension components of the first supporting element opposite to the first relative displacement in the first supporting element results in a synchronous opposite relative displacement between the two identical extension components of the at least one second supporting element.

By means of this arrangement, the opposite relative displacement between two identical extension components between the two supporting elements can also be easily executed.

In a further advantageous implementation of the supporting device, the first and second rope-like elements are respectively a steel band.

The use of the steel band enables the use of deflection rollers having a small diameter and, due to a small elongation of the steel band, a precisely defined synchronization of the relative movement amongst the first supporting element and the second supporting element relative to one another is possible.

In a further advantageous implementation of the supporting device, the first deflection rollers and second deflection rollers have a convexity on their running surface along their axis of rotation.

As a result, self-centring takes place during the running of the steel band so that reliable operation is possible without additional centring devices.

According to the invention, the supporting device comprises a drive or assist element which drives or assists the changes in length of the first supporting element and of the at least one second supporting element.

- 5 By using the drive or assist element, the table top can be adjusted, in particular, in the case of a high load, without or with a low muscle force expenditure.

In a further advantageous implementation of the supporting device, the drive or assist element is a gas compression spring.

10

The gas compression spring as the drive or assist element has a small space requirement and can be provided cost-effectively.

15

In a further advantageous implementation of the supporting device, the gas compression spring is arranged in at least one of the first and the at least one second supporting element.

20

By the coupling of the extension components, it is possible to install a gas compression spring in the supporting element, since the stroke length of the gas compression springs can be smaller than the maximum change in length of the supporting element. As a result, the gas compression spring in its retracted state has a length which is smaller than the available installation space. Thus, a compact design and a smaller overall assembly effort are enabled since the supporting element with the gas spring can already be easily pre-assembled and, thus, an effort in the final assembly is reduced.

25

According to another advantageous implementation of the supporting device, the gas compression spring is provided between the first supporting element and the at least one second supporting element and is configured to apply a drive or assist force to the rope-like synchronization element.

30

According to this implementation, it is possible to provide the supporting elements with a smaller cross section since the space requirement of the gas spring in the supporting element is eliminated so that design requirements can be implemented more easily.

According to the invention, the drive or assist element is configured to apply a drive or assist force between the first extension component and the second extension component.

5 By such an application of the drive or assist force, the drive or assist element can be designed with a shorter travel path and, thus, with a required installation space with a smaller length since the coupling of the first, second, and third extension components results in a greater change in length of the supporting elements than the change in length of the drive or assist element.

10 According to a further aspect of the invention, a height-adjustable table is provided with a supporting device.

In such a height-adjustable table, it is enabled that bending moments applied to the supporting elements, for example, as a result of resting on the edge of a table top during a height
15 adjustment or as a result of relatively large eccentrically placed loads on the table top, can be offset without excessively loading guides or sliding pieces which enable the extension components to be moved into one another as backlash-free as possible. Furthermore, the movement for the height adjustment is carried out in a synchronized manner so that tilting of the several supporting elements cannot occur.

20 Subsequently, the invention is explained on the basis of exemplary embodiments with reference to the accompanying drawings.

In particular,

25 FIG. 1 shows a schematic diagram of a height-adjustable table according to the invention;

FIG. 1a shows a schematic diagram of a supporting element of a height-adjustable table according to the invention;

30 FIG. 2 shows a schematic diagram of a supporting element with a coupling device of a first, second, and third extension component; and

FIG. 3 shows a cross-sectional view of a deflection roller.

FIG. 1 shows a schematic diagram of a height-adjustable table 1 according to the invention.

The height-adjustable table 1 comprises a table top 2 and a supporting device having a first supporting element 3 and a second supporting element 3'. The supporting elements 3, 3' here form table legs in which a change in length L is possible in order to adjust the table top 2 in its height. The supporting elements 3, 3' are connected to one another by means of a crossbar 4 and are fastened to the table top 2 at a suitable distance. In an alternative embodiment, the supporting elements 3, 3' are fastened individually to the table top without having the crossbar 4. In further alternative embodiments, more than two supporting elements 3, 3' are provided.

FIG. 1a shows an enlarged schematic diagram of the supporting element 3.

The supporting elements 3, 3' respectively comprise a first extension component 5, 5', a second extension component 6, 6', and a third extension component 7, 7'. The first extension component 5, 5', the second extension component 6, 6', and the third extension component 7, 7' are arranged displaceably relative to one another in order to respectively effect the change in length L of the first supporting element 3 and of the second supporting element 3'. The second extension component 6, 6' is arranged between the first extension component 5, 5' and the third extension component 7, 7' in the direction of the change in length L. The first extension component 5, 5' is connected to the table top 2. The third extension component 7, 7' is connected to a table foot (not shown) such that the height-adjustable table 1 can stand on a floor without tilting.

The supporting device further comprises, in each of the supporting elements 3, 3', a drive or assist element 17, 17' which drives or assists the change in length L of the first supporting element 3 and of the second supporting element 3'. The assist element 17, 17' assists, for example, a human muscle force during the height adjustment of the table top in order to reduce the force required. The drive element, on the other hand, carries out the height adjustment of the table top without human muscle force.

In this embodiment, the drive or assist element 17, 17' is a gas compression spring. In alternative embodiments, for example, a hydraulic cylinder or an electromotively operated linear drive can be provided. In further alternative embodiments, one of the drive or assist

elements 17, 17' is not provided for each of the supporting elements 3, 3', but only, for example, a single drive or assist element 17, 17' for one of the supporting elements 3, 3'.

5 The gas compression springs are arranged in the supporting elements 3, 3'. In alternative embodiments, the gas compression springs are arranged outside the supporting elements 3, 3'.

10 The drive or assist element 17, 17' is configured to apply a drive or assist force between the first extension component 5, 5' and the second extension component 6, 6'. In an alternative embodiment, the drive or assist element 17, 17' is configured to apply a drive or assist force between the second extension component 6, 6' and the third extension component 7, 7'.

15 The supporting device further comprises a synchronization device which is configured to synchronize, amongst the first supporting element 3 and the second supporting element 3', the displacement of the second extension component 6, 6' relative to the first extension component 5, 5' or the displacement of the third extension component 7, 7' relative to the second extension component 6, 6'.

20 The synchronization device comprises a first rope-like synchronization element 11 which is fastened at one end to one of the extension components, in this embodiment to the second extension component 6, of the first supporting element 3 and is fastened at the other end to the same of the extension components, here also to the second extension component 6', of the second supporting element 3'. Furthermore, the synchronization device comprises two first deflection rollers 12, 13 which are respectively fastened to another one of the extension components, in this embodiment to the first extension component 5, 5'. A deflection of the first rope-like synchronization element 11 is effected by means of the two first deflection rollers 12, 13 in such a way that the relative displacement RV between two of the extension components, in this embodiment between the second extension component 6 and the first extension component 5, of the first supporting element 3 results in a synchronous relative displacement RV between the two identical extension components, in this embodiment between the second extension component 6' and the first extension component 5', of the second supporting element 3'.

In alternative embodiments, the first rope-like synchronization element 11 and the two first deflection rollers 12, 13 can also be attached to other extension components 5, 5', 6, 6', 7, 7' of

the first supporting element 3 and of the second supporting element 3', wherein it is essential that the two extension components 5, 5', 6, 6', 7, 7' are respectively different and the extension component 5, 5', 6, 6', 7, 7' on the first supporting element 3 and the second supporting element 3' is respectively the same extension component 5, 5', 6, 6', 7, 7'.

5

The synchronization device further comprises a second rope-like synchronization element 14 which is fastened at one end to one of the extension components, in this embodiment to the second extension component 6, of the first supporting element 3 and is fastened at the other end to the same of the extension components, here also to the second extension component 6', of the second supporting element 3'. Further, the synchronization device comprises two second deflection rollers 15, 16 which are respectively fastened to another one of the extension components, in this embodiment to the first extension component 5, 5'. A deflection of the second rope-like synchronization element 14 is effected by means of the two second deflection rollers 15, 16 in such a way that an opposite relative displacement RV' between two of the extension components, in this embodiment between the third extension component 7 and the first extension component 5, of the first supporting element 3 results in an opposite relative displacement RV' between the two identical extension components, in this embodiment between the second extension component 6' and the first extension component 5', of the second supporting element 3'.

20

In alternative embodiments, the second rope-like synchronization element 14 and the two second deflection rollers 15, 16 can also be attached to other extension components 5, 5', 6, 6', 7, 7' of the first supporting element 3 and of the second supporting element 3', wherein it is essential that the two extension components 5, 5', 6, 6', 7, 7' of one of the supporting elements 3, 3' are respectively different and the extension component 5, 5', 6, 6', 7, 7' on the first supporting element 3 and the second supporting element 3' is respectively the same extension component 5, 5', 6, 6', 7, 7'.

The first rope-like synchronization element 11 and the second rope-like synchronization element 14 are respectively configured as a steel band. In alternative embodiments, the first rope-like synchronization element 11 and the second rope-like synchronization element 14 can also be respectively configured, for example, as a plastic band or a steel cable.

30

FIG. 2 shows a schematic diagram of one of the supporting elements 3 with a coupling device of the first extension component 5, the second extension component 6, and the third extension component 7. The first extension component 5, the second extension component 6, and the third extension component 7 are coupled to one another such that, upon the change in length L of the first supporting element 3, a displacement of the second extension component 6 relative to the first extension component 5 in a direction parallel to the change in length L synchronously causes a displacement of the third extension component 7 relative to the second extension component 6 in the same direction. The second supporting element 3' comprises an identical coupling device.

10 As the coupling device, the supporting device 3 comprises an endless rope-like element 8. Further, the supporting device 3 comprises two third deflection rollers 9, 10 which are arranged spaced apart in the direction of the change in length L and are connected to the second extension component 6. The endless rope-like element 8 is configured such that it is deflected without backlash by the two third deflection rollers 9, 10 and a portion 8.1, 8.2 is respectively connected to the first extension component 5 and the third extension component 7 in the direction of the change in length L between the two third deflection rollers 9, 10. Hereby, the portion 8.1 is connected to the first extension component 5 and the portion 8.2 is connected to the third extension component 7.

20 An extent of the displacement between the second extension component 6 and the first extension component 5 and an extent of the displacement between the third extension component 7 and the second extension component 6 are identical in this embodiment.

25 In alternative embodiments, if a coupling of the different extension components 5, 5', 6, 6', 7, 7' takes place, for example, via threaded rods coupled to one another with different pitches, the extent of the displacement between the second extension component 6, 6' and the first extension component 5, 5' and the extent of the displacement between the third extension component 7, 7' and the second extension component 6, 6' can be different.

30 The rope-like element 8 is configured as a steel band. In alternative embodiments, the rope-like element 8 can also be configured, for example, as a plastic band or a steel cable.

FIG. 3 shows a cross-sectional view of one of the deflection rollers 9, 10, 12, 13, 14, 15.

The first, second, and third deflection rollers 9, 10, 12, 13, 14, 15 have a convexity on their running surface along their axis of rotation, namely a bulge of the running surface towards the centre of the running surface. In alternative embodiments, at least some of the first, second, and third deflection rollers 9, 10, 12, 13, 14, 15 can also be provided with a straight running surface along their axis of rotation.

In an alternative embodiment, the gas compression spring is provided between the first supporting element 3 and the second supporting element 3' and is configured to apply the drive or assist force to the first or second rope-like synchronization element 11, 14.

In a further alternative embodiment, the synchronization device is not provided with rope-like synchronization elements, but the synchronization takes place, for example, via an axle having a bevel gear transmission on both sides and respective threaded spindles.

All features illustrated in the description, the following claims, and the drawing can be essential to the invention both individually and in any combination with one another.

KRAV**1. Støtteenhed til et højdejusterbart bord (1), der består af:**

et første støtteelement (3) og mindst ét andet støtteelement (3'), hvor det første støtteelement (3) og det mindst ene andet støtteelement (3'), hvor hver

5 består af en første forlængelseskomponent (5, 5'), en anden forlængelseskomponent (6, 6') og en tredje forlængelseskomponent (7, 7'), hvor

den første forlængelseskomponent (5, 5'), den anden forlængelseskomponent (6, 6') og den tredje forlængelseskomponent (7, 7') er arrangeret således, at de kan forskydes i forhold til hinanden for at forårsage en ændring i længden (L) af det første støtteelement (3) og mindst et andet støtteelement (3').

den anden forlængelseskomponent (6, 6') er arrangeret i retning af ændringen i længden (L) mellem den første forlængelseskomponent (5, 5') og den tredje forlængelseskomponent (7, 7').

15 den første forlængelseskomponent (5, 5'), den anden forlængelseskomponent (6, 6') og den tredje forlængelseskomponent (7, 7') er koblet til hinanden på en sådan måde, at under ændringen i længden (L) af det første støtteelement (3) og det mindst ene andet støtteelement (3'), forårsager en forskydning af den anden forlængelseskomponent (6, 6') i forhold til den første forlængelseskomponent (5, 5') i en retning parallelt med ændringen i længden (L) synkront en forskydning af den tredje forlængelseskomponent (7, 7') i forhold til den anden forlængelseskomponent (6, 6') i samme retning.

20 og en synkroniseringsenhed, som er designet til at synkronisere, mellem det første støtteelement (3) og det mindst ene andet støtteelement (3'), forskydningen af den anden forlængelseskomponent (6, 6') i forhold til den første forlængelseskomponent (5, 5') eller forskydningen af den tredje forlængelseskomponent (7, 7') i forhold til den anden forlængelseskomponent (6, 6'),

hvor

25 Støtteenheden omfatter et drev- eller hjælpeelement (17, 17'), som driver eller hjælper med ændringen i længden (L) af det første støtteelement (3) og det mindst ene andet støtteelement (3'), og

30 drev- eller hjælpeelementet (17, 17') er designet til at påføre en køre- eller hjælpekraft mellem den første forlængelseskomponent (5, 5') og den anden forlængelseskomponent (6, 6'),

hvor

synkroniseringsenheden består af:

et første reb-lignende synkroniseringselement (11), som er fastgjort i den ene ende til en af forlængelseskomponenterne (5, 6, 7) af det første støtteelement (3) og er fastgjort i den anden ende til den samme af forlængelseskomponenterne (5', 6', 7') af mindst det ene andet støtteelement (3'),

to første afbøjningsruller (12, 13), som hver er fastgjort til en anden af forlængelseskomponenterne (5, 5', 6, 6', 7, 7') af det første støtteelement (3) og det mindst ene andet støtteelement (3, 3'), hvor den anden af

forlængelseskomponenterne (5, 5', 6, 6', 7, 7') af det første støtteelement (3) og det mindst ene andet støtteelement (3') er henholdsvis den samme forlængelseskomponent (5, 5', 6, 6', 7, 7'), hvor

en afbøjning af det første reb-lignende synkroniseringselement (11) finder sted ved hjælp af de første afbøjningsruller (12, 13) på en sådan måde, at en første relativ forskydning (RV) mellem to af forlængelseskomponenterne (5, 6, 7) af det første støtteelement (3) resulterer i en synkron relativ forskydning (RV) mellem de to samme forlængelseskomponenter (5', 6', 7') af det mindst ene andet støtteelement (3'), og

det første reb-lignende synkroniseringselement (11) er fastgjort til den anden forlængelseskomponent (6, 6').

20 **2.** Støtteanordning i henhold til krav 1, hvor

omfanget af forskydningen mellem den anden forlængelseskomponent (6, 6') og den første forlængelseskomponent (5, 5') og omfanget af forskydningen mellem den tredje forlængelseskomponent (7, 7') og den anden forlængelseskomponent (6, 6') er identiske.

3. Støtteenhed ifølge et af kravene 1 eller 2, hvor

25 støtteenheden består af

et endeløst reb-lignende element (8), og

to tredje afbøjningsruller (9, 10), som er arrangeret med afstand i retning af ændringen i længden (L) og er forbundet til den anden forlængelseskomponent (6, 6'), hvor

30 det endeløse reb-lignende element (8) er designet til at blive afbøjet på en spilfri måde af de to tredje afbøjningsruller (9, 10), og en del (8.1, 8.2) af det endeløse reb-lignende element (8) i retning af ændringen i længden (L) mellem de to tredje afbøjningsruller (9, 10) er forbundet til henholdsvis den første forlængelseskomponent (5, 5') og den tredje forlængelseskomponent (7, 7').

4. Støtteanordning i henhold til krav 3, hvor

det reb-lignende element (8) er en stålband.

5. Støtteenhed ifølge et af kravene 3 eller 4, hvor
de tredje afbøjningsruller (9, 10) har en konveksitet på deres løbeflade langs deres
rotationsakse.
- 5 6. Støtteenhed i henhold til et af de foregående krav, hvor
synkroniseringsenheden består af:
et andet reb-lignende synkroniseringselement (14), som er fastgjort i den ene ende til en
af forlængelseskomponenterne (5, 6, 7) af det første støtteelement (3) og er fastgjort i
den anden ende til den samme af forlængelseskomponenterne af det mindst ene andet
10 støtteelement, og
andre afbøjningsruller (15, 16), som hver især er fastgjort til den anden af
forlængelseskomponenterne (5, 5', 6, 6', 7, 7') af det første støtteelement (3) og det
mindst ene andet støtteelement (3'), hvor den anden af forlængelseskomponenterne (5,
5', 6, 6', 7, 7') af det første støtteelement (3) og det mindst ene andet støtteelement (3')
15 henholdsvis er den samme forlængelseskomponent (5, 5', 6, 6', 7, 7'), hvor
en afbøjning af det andet reb-lignende synkroniseringselement (14) finder sted ved
hjælp af de andet afbøjningsruller (15, 16) på en sådan måde, at en modsat relativ
forskydning (RV') mellem to af forlængelseskomponenterne (5, 6, 7) af det første
støtteelement (3) modsat den første relative forskydning (RV) i det første støtteelement
20 (3) resulterer i en synkron modsat relativ forskydning (RV') mellem de to samme
forlængelseskomponenter (5', 6', 7') af det mindst ene andet støtteelement (3).
7. Støtteanordning i henhold til krav 6, hvor
det første reb-lignende synkroniseringselement (11) og det andet reb-lignende
synkroniseringselement (14) er hver en stålband.
- 25 8. Støtteenhed ifølge et af kravene 6 eller 7, hvor
de første afbøjningsruller (12, 13) og andre afbøjningsruller (15, 16) har en konveksitet på
deres løbeflade langs deres rotationsakse.
9. Støtteenhed i henhold til et af de foregående krav, hvor
drev- eller hjælpeelementet (17, 17') er en gasfjeder.
- 30 10. Støtteanordning i henhold til krav 9, hvor
gasfjederen er placeret i mindst ét af det første støtteelement (3) og det mindst ene andet
støtteelement (3').
11. Støtteanordning i henhold til krav 9, hvor

gasfjederen er placeret mellem det første støtteelement (3) og det mindst ene andet støtteelement (3') og er designet til at påføre en køre- eller hjælpekraft til det reb-lignende synkroniseringselement (11, 14).

12. Højdejusterbart bord (1) med en støtteanordning i henhold til et af de foregående krav.

Drawings

Fig. 1

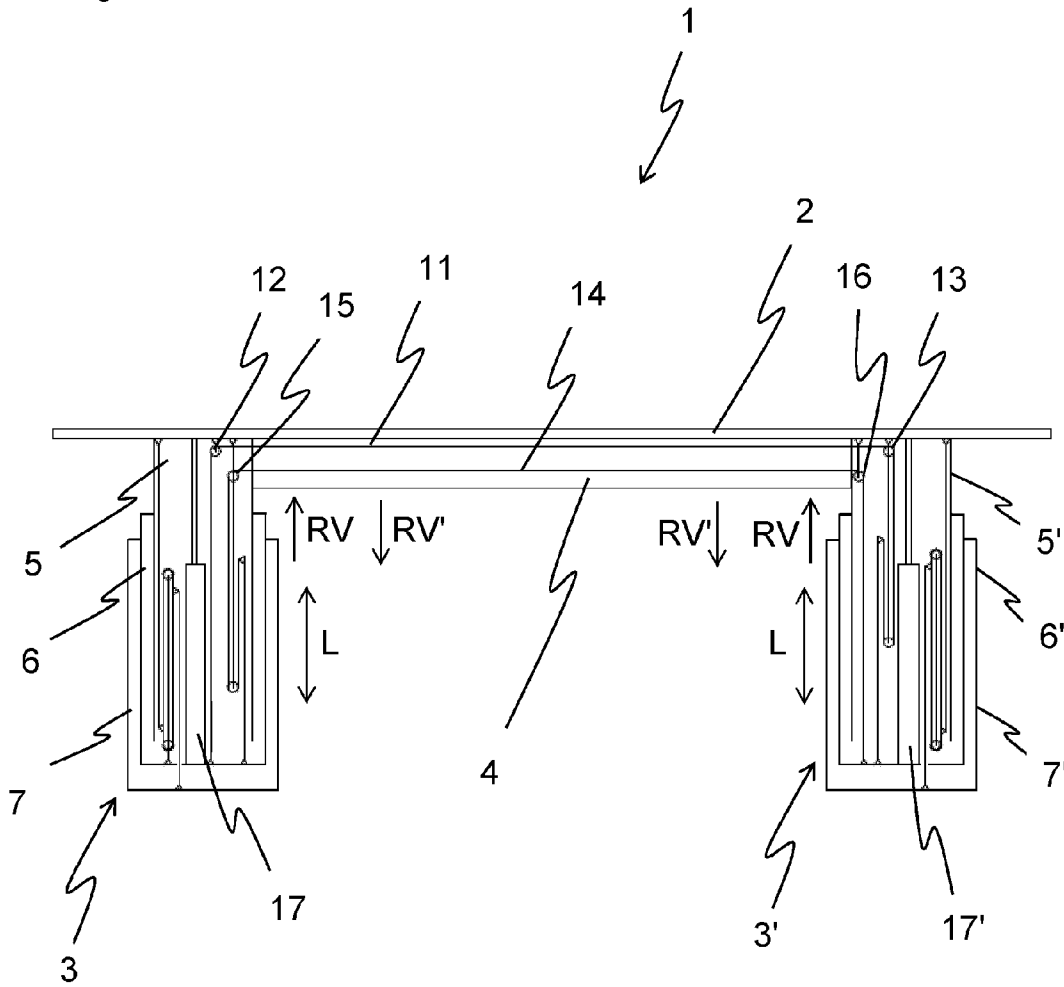

Fig. 1a

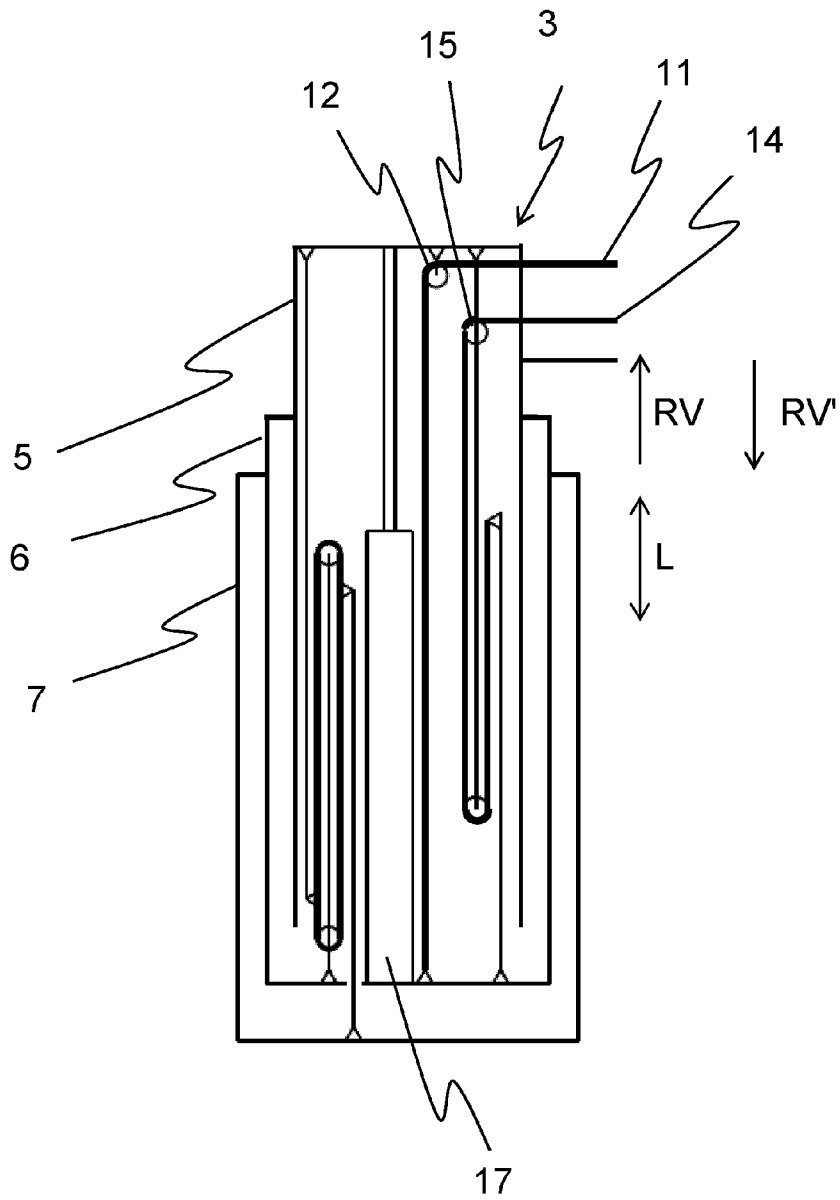

Fig. 2

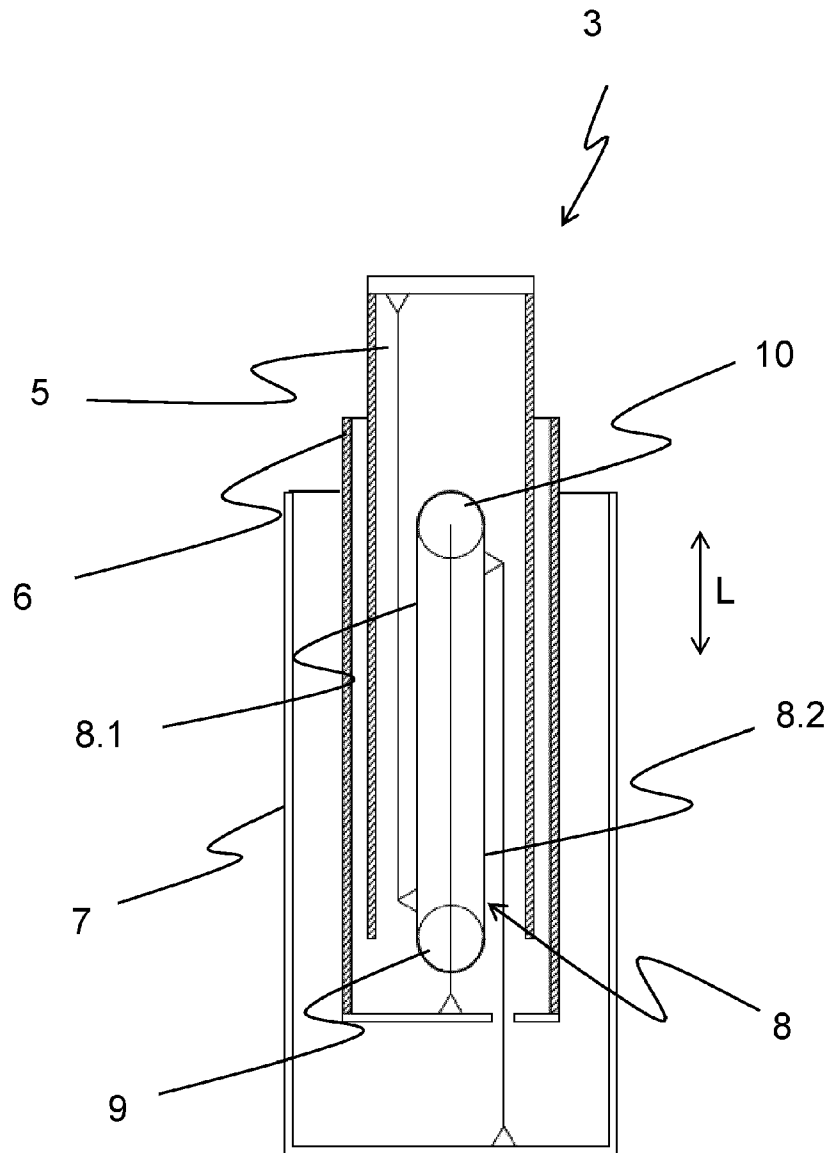

Fig. 3

