

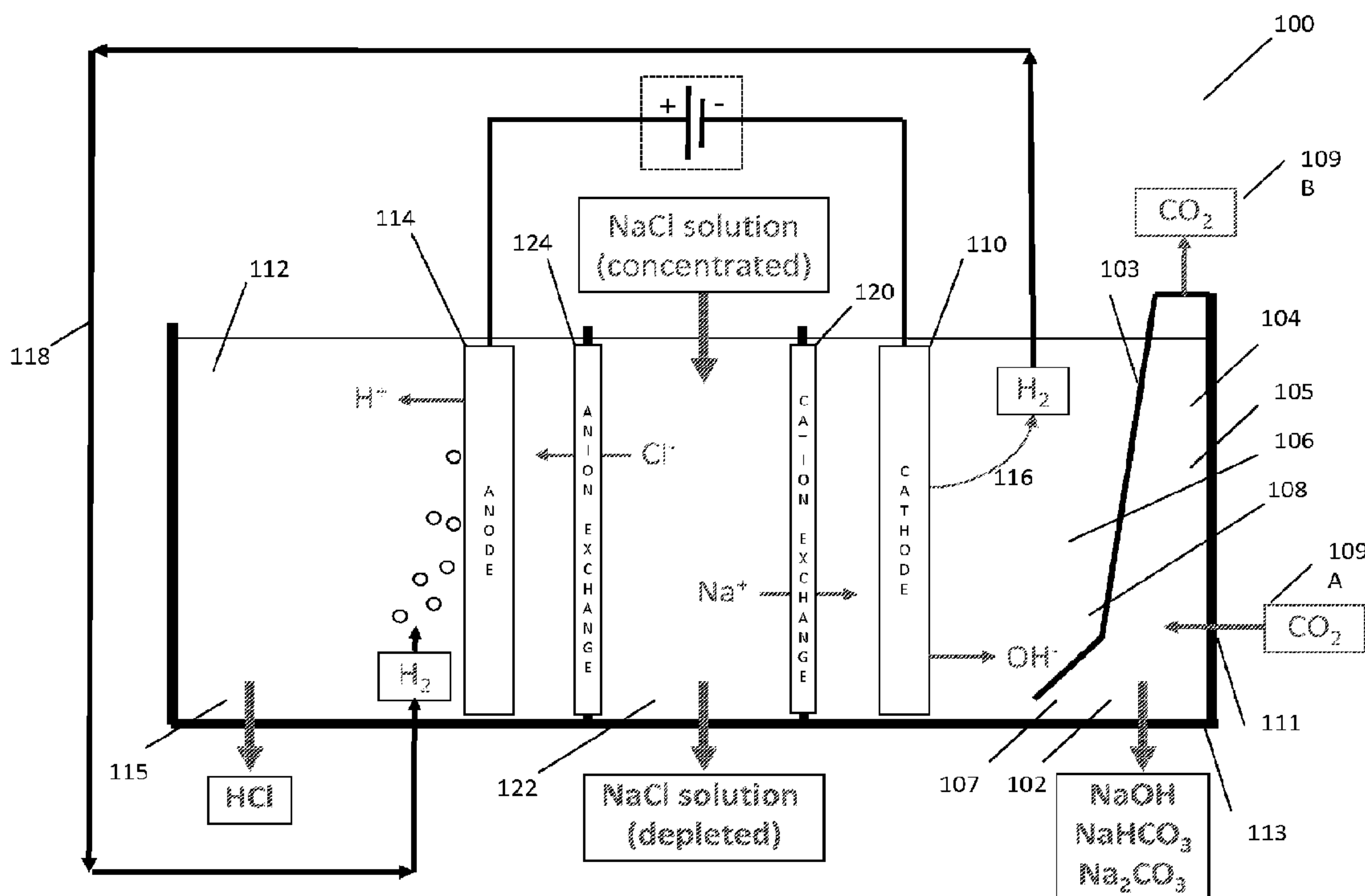

(86) Date de dépôt PCT/PCT Filing Date: 2009/07/15
 (87) Date publication PCT/PCT Publication Date: 2010/01/21
 (45) Date de délivrance/Issue Date: 2014/09/09
 (85) Entrée phase nationale/National Entry: 2010/03/24
 (86) N° demande PCT/PCT Application No.: US 2009/050756
 (87) N° publication PCT/PCT Publication No.: 2010/009273
 (30) Priorités/Priorities: 2008/07/16 (US61/081,299);
 2008/08/25 (US61/091,729);
 2008/12/23 (USPCT/US2008/088242);
 2009/01/28 (USPCT/US2009/032301);
 2009/06/24 (USPCT/US2009/048511);
 2009/07/01 (US61/222,456)

(51) Cl.Int./Int.Cl. *C25B 1/16* (2006.01)
 (72) Inventeurs/Inventors:
 GILLIAM, RYAN J., US;
 ALBRECHT, THOMAS A., US;
 JALANI, NIKHIL, US;
 KNOTT, NIGEL ANTONY, US;
 DECKER, VALENTIN, US;
 KOSTOWSKYJ, MICHAEL, US;
 BOGGS, BRYAN, US;
 ...
 (73) Propriétaire/Owner:
 CALERA CORPORATION, US
 (74) Agent: GOWLING LAFLEUR HENDERSON LLP

(54) Titre : UTILISATION DU CO₂ DANS DES SYSTEMES ELECTROCHIMIQUES
 (54) Title: CO₂ UTILIZATION IN ELECTROCHEMICAL SYSTEMS



(57) Abrégé/Abstract:

A low-voltage, low-energy electrochemical system and method of removing protons and/or producing a base solution comprising hydroxide and carbonate/bicarbonate ions, utilizing carbon dioxide in a cathode compartment that is partitioned into a first cathode electrolyte compartment and a second cathode electrolyte compartment such that liquid flow between the cathode electrolyte compartments is possible, but wherein gaseous communication between the cathode electrolyte compartments is restricted. Carbon dioxide gas in one cathode electrolyte compartment is utilized with the cathode electrolyte in both compartments to produce the base solution with less than 3V applied across the electrodes.

(72) Inventeurs(suite)/Inventors(continued): GORER, ALEXANDER, US; FARSAD, KASRA, US

(12) INTERNATIONAL APPLICATION PUBLISHED UNDER THE PATENT COOPERATION TREATY (PCT)

(19) World Intellectual Property Organization
International Bureau(43) International Publication Date
21 January 2010 (21.01.2010)

PCT

(10) International Publication Number
WO 2010/009273 A1

(51) International Patent Classification:

C25B 1/00 (2006.01) B01D 61/42 (2006.01)

(21) International Application Number:

PCT/US2009/050756

(22) International Filing Date:

15 July 2009 (15.07.2009)

(25) Filing Language:

English

(26) Publication Language:

English

(30) Priority Data:

61/081,299	16 July 2008 (16.07.2008)	US
61/091,729	25 August 2008 (25.08.2008)	US
PCT/US2008/088242	23 December 2008 (23.12.2008)	US
PCT/US2009/032301	28 January 2009 (28.01.2009)	US
PCT/US2009/048511	24 June 2009 (24.06.2009)	US
61/222,456	1 July 2009 (01.07.2009)	US

(71) Applicant (for all designated States except US):
CALERA CORPORATION [US/US]; 14600 Winchester Blvd., Los Gatos, CA 95060 (US).

(72) Inventors; and

(75) Inventors/Applicants (for US only): **GILLIAM, Ryan** [CA/US]; 350 Budd Avenue, Unit #M-11, Campbell, CA 95008 (US). **ALBRECHT, Thomas, A.** [US/US]; 255 S. Rengstorff Avenue, Apt. #141, Mountain View, CA 94040 (US). **JALANI, Nikhil** [IN/US]; 600 MarathonDrive, Apt. #46, Campbell, CA 95008 (US). **KNOTT, Nigel, Antony** [CA/US]; 350 Budd Avenue, Unit #L-10, Campbell, CA 95008 (US). **DECKER, Valentin** [US/US]; 1342 Sherman Avenue, Menlo Park, CA 94025 (US). **KOSTOWSKYJ, Michael** [CA/US]; 350 Budd Avenue, Unit #L-10, Campbell, CA 95008 (US). **BOGGS, Bryan** [US/US]; 225 Union Avenue, Apt. #148, Campbell, CA 95008 (US). **GORER, Alexander** [US/US]; 112 Mill Road, Los Gatos, CA 95032 (US). **FARSAD, Kasra** [US/US]; 677 Colleen Drive, San Jose, CA 95123 (US).(74) Agent: **SCHERER, David, C.**; Bozicevic, Field & Francis, LLP, 1900 University Avenue, Suite 200, East Palo Alto, CA 94303 (US).

(81) Designated States (unless otherwise indicated, for every kind of national protection available): AE, AG, AL, AM, AO, AT, AU, AZ, BA, BB, BG, BH, BR, BW, BY, BZ, CA, CH, CL, CN, CO, CR, CU, CZ, DE, DK, DM, DO, DZ, EC, EE, EG, ES, FI, GB, GD, GE, GH, GM, GT, HN, HR, HU, ID, IL, IN, IS, JP, KE, KG, KM, KN, KP, KR, KZ, LA, LC, LK, LR, LS, LT, LU, LY, MA, MD, ME, MG, MK, MN, MW, MX, MY, MZ, NA, NG, NI, NO, NZ, OM, PE, PG, PH, PL, PT, RO, RS, RU, SC, SD, SE, SG, SK, SL, SM, ST, SV, SY, TJ, TM, TN, TR, TT, TZ, UA, UG, US, UZ, VC, VN, ZA, ZM, ZW.

(84) Designated States (unless otherwise indicated, for every kind of regional protection available): ARIPO (BW, GH, GM, KE, LS, MW, MZ, NA, SD, SL, SZ, TZ, UG, ZM,

[Continued on next page]

(54) Title: CO₂ UTILIZATION IN ELECTROCHEMICAL SYSTEMS

Fig. 1

(57) Abstract: A low-voltage, low-energy electrochemical system and method of removing protons and/or producing a base solution comprising hydroxide and carbonate/bicarbonate ions, utilizing carbon dioxide in a cathode compartment that is partitioned into a first cathode electrolyte compartment and a second cathode electrolyte compartment such that liquid flow between the cathode electrolyte compartments is possible, but wherein gaseous communication between the cathode electrolyte compartments is restricted. Carbon dioxide gas in one cathode electrolyte compartment is utilized with the cathode electrolyte in both compartments to produce the base solution with less than 3V applied across the electrodes.

WO 2010/009273 A1 

ZW), Eurasian (AM, AZ, BY, KG, KZ, MD, RU, TJ, TM), European (AT, BE, BG, CH, CY, CZ, DE, DK, EE, ES, FI, FR, GB, GR, HR, HU, IE, IS, IT, LT, LU, LV, MC, MK, MT, NL, NO, PL, PT, RO, SE, SI, SK, SM, TR), OAPI (BF, BJ, CF, CG, CI, CM, GA, GN, GQ, GW, ML, MR, NE, SN, TD, TG). **Published:** — *with international search report (Art. 21(3))*

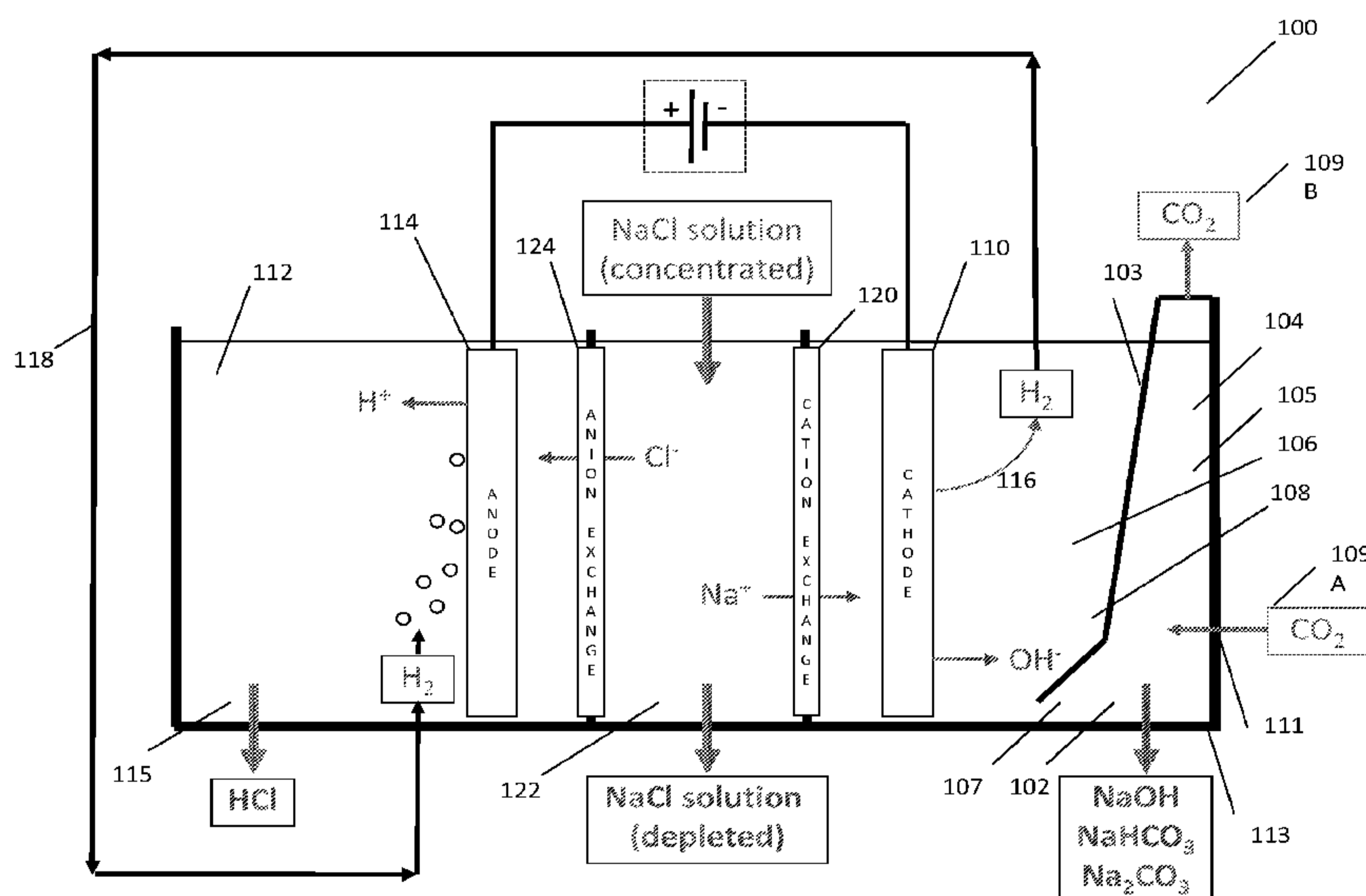
CO₂ UTILIZATION IN ELECTROCHEMICAL SYSTEMS**[0001]**5 **[0002]****[0003]****[0004]**

10

15

BACKGROUND OF THE INVENTION

20 **[0005]** In many industrial processes a large amount of hydroxide ions in a base solution is utilized to achieve a desired reaction, e.g., to neutralize an acid, or buffer the pH of a solution, or precipitate an insoluble hydroxide and/or carbonate and/or bicarbonate from a solution. One method by which the hydroxide ions are produced is by an electrochemical system. In producing the hydroxide ions electrochemically, a large amount of electrical energy is used; consequently, minimizing the electrical energy used is highly desired.

25

SUMMARY OF THE INVENTION

[0006] This invention pertains to a low-voltage, low-energy electrochemical system and method of removing protons, or producing hydroxide ions or both in a cathode electrolyte while dissolving carbon dioxide gas in the cathode electrolyte. In the system, in various embodiments, the cathode electrolyte is partitioned into a first cathode electrolyte compartment and a second cathode electrolyte compartment such that the cathode electrolytes in the two cathode electrolyte compartments are in contact with each other. However, since gas flow between the two cathode electrolyte compartments is restricted, carbon dioxide gas provided to the first cathode electrolyte compartment is prevented from contacting cathode electrolyte in the second cathode electrolyte compartment.

30 **[0007]** In the system, the cathode is in contact with the cathode electrolyte in the second cathode electrolyte compartment and both the cathode electrolyte and the anode electrolyte are composed of an

35

aqueous solution. In the system, by absorbing carbon dioxide in the cathode electrolyte to form carbonate and bicarbonate ions and also to affect the pH of the cathode electrolyte, the hydroxide ions are produced in the cathode electrolyte with a relatively low voltage across the anode and cathode e.g., a voltage of 3V or less, such as 2V or less, or 1V or less.

5 **[0008]** In the system, water in the cathode electrolyte is reduced to hydrogen gas and hydroxide ions at the cathode. At the anode, hydrogen gas, provided to the anode from an external source, is oxidized to hydrogen ions. In some embodiments, the hydrogen gas produced at the cathode is directed to the anode for oxidation to hydrogen ions. In the system, a gas, e.g., oxygen or chlorine is not produced at the anode when the low voltage is applied across the anode and cathode. In the system, hydrogen ions produced at the anode
10 migrate into the anode electrolyte to form an acid solution in the anode electrolyte; and, in the system, hydroxide ions produced at the cathode migrate into the cathode electrolyte to produce the base solution in the cathode electrolyte.

[0009] In the system, the carbon dioxide gas provided to the cathode electrolyte in the first cathode electrolyte compartment dissolves to produce carbonic acid. Depending on the pH of the cathode electrolyte,
15 the carbonic acid in the cathode electrolyte dissociate into carbonate ions and bicarbonate ions. Thus, in the system, since the cathode electrolyte in the first compartment can mix with the cathode electrolyte in the second cathode electrolyte compartment, mixing of the cathode electrolytes in the two cathode electrolyte compartments will result in the cathode electrolyte comprising carbonic acid, hydroxide ions and/or carbonate ions and/or bicarbonate ions.

20 **[0010]** In the system, the voltage across the cathode and anode is dependent on several factors including the difference in the pH value of the anode electrolyte and the cathode electrolyte, as well as the ohmic resistances between the cathode and anode. Thus, in various embodiments, by controlling the difference in pH between the cathode electrolyte and the anode electrolyte, e.g., by dissolving more or less carbon dioxide in the cathode electrolyte, the system will produce hydroxide ions and/or carbonate ions
25 and/or bicarbonate ions in the cathode electrolyte while minimizing the voltage across the anode and cathode, thus minimizing the use of electrical energy.

[0011] In one embodiment, the invention provides a system comprising a cathode compartment partitioned into a first cathode electrolyte compartment and a second cathode electrolyte compartment by a partition wherein, cathode electrolyte in the second cathode electrolyte compartment is in contact with a
30 cathode, and anode electrolyte in an anode compartment is in contact with an anode.

[0012] In another embodiment, the invention provides a method comprising directing a gas into a cathode electrolyte in a first cathode electrolyte compartment; and applying a voltage across a cathode in contact with cathode electrolyte in a second cathode electrolyte compartment that is partitioned from the first cathode electrolyte compartment, and an anode that is in contact with an anode electrolyte.

35 **[0013]** In various embodiments, by partitioning the cathode electrolyte into the first and second cathode electrolytes compartments, and by restricting carbon dioxide gas to the first cathode electrolyte compartment, contact between the carbon dioxide gas and the cathode and/or with the anode and/or with other electrolytes in the system is restricted. Thus, advantageously, in the system, carbon dioxide gas from a variety of sources,

including carbon dioxide from industrial waste gases, e.g., from burning fossil fuels in electrical generating plants and from cement plants, can be utilized. Also, by restricting carbon dioxide gas to the first cathode electrolyte compartment, mixing of carbon dioxide gas with other gases in the system, e.g., mixing of the carbon dioxide with hydrogen gas generated at the cathode, or mixing of carbon dioxide with hydrogen gas supplied to the anode, is avoided.

BRIEF DESCRIPTION OF THE DRAWINGS

[0014] The following drawings illustrate by way of examples and not by limitation embodiments of the present system and method.

10 **[0015]** Fig. 1 is an illustration of an embodiment of the present system.

[0016] Fig. 2 is an illustration of an embodiment of the present system.

[0017] Fig. 3 is an illustration of an embodiment of the present system.

[0018] Fig. 4 is an illustration of the voltage across the anode and cathode vs. the pH of the cathode electrolyte achieved by adding CO₂ to the cathode electrolyte.

15 **[0019]** Fig. 5 is a flow chart of an embodiment of the present method.

Fig. 6 is chart of carbonate composition with ph and temperatures

Fig. 7 is a chart of bicarbonate ion generation in the cathode electrolyte

DETAILED DESCRIPTION OF THE INVENTION

20 **[0020]** In the following detailed description, unless defined otherwise, all technical and scientific terms have the same meaning as commonly understood by one of ordinary skill in the art to which this invention pertains. Herein, all cited publications and patents are incorporated by reference herein in their entirety. Herein, the date cited for publication may differ from the actual publication dates; thus, an actual publication should be independently confirmed. Herein, the singular "a," "an," and "the" include plural references unless the context clearly dictates otherwise.

25 **[0021]** Herein, exemplarity systems and methods are disclosed wherein sodium chloride solution is used in one compartment between the anode electrolyte and cathode electrolyte to produce sodium hydroxide and /or sodium carbonate ions and/or sodium bicarbonate in the cathode electrolyte, and hydrochloric acid in the anode electrolyte. However, as will be appreciated by one ordinarily skilled in the art, the system and method are not limited to the use of sodium chloride solution as disclosed in these exemplarity embodiments since the
30 system and method are capable of using an equivalent salt solution, e.g., an aqueous solution of potassium sulfate and the like to produce an equivalent result. Similarly, in preparing the electrolytes for the system, it will be appreciated that water from various sources can be used including seawater, brackish water, brines or naturally occurring fresh water, provided that the water is purified to an acceptable level for use in the system. Therefore, to the extent that such equivalents embody the present system and method, these equivalents are
35 within the scope of the appended claims.

[0022] As disclosed in U.S. Provisional Patent Application No. 61/081,299 filed July 16, 2008, titled: "Low Energy pH Modulation for Carbon Sequestration Using Hydrogen Absorptive Metal Catalysts" (available

on the USPTO Public Pair website) in various embodiments, the anode and the cathode of the present system may comprise a noble metal, a transition metal, a platinum group metal, a metal of Groups IVB, VB, VIB, or VIII of the periodic table of elements, alloys of these metals, or oxides of these metals. Exemplary materials include palladium, platinum, iridium, rhodium, ruthenium, titanium, zirconium, chromium, iron, cobalt, nickel, palladium-silver alloys, and palladium-copper alloys. In various embodiments, the cathode and/or the anode may be coated with a reactive coating comprising a metal, a metal alloy, or an oxide, formed by sputtering, electroplating, vapor deposition, or any convenient method of producing a layer of reactive coating on the surface of the cathode and/or anode. In other embodiments, the cathode and/or the anode may comprise a coating designed to provide selective penetration and/or release of certain chemicals or hydroxide ions and/or anti-fouling protection. Exemplary coatings include non-metallic polymers; in specific embodiments herein, an anode fabricated from a 20-mesh Ni gauze material, and a cathode fabricated from a 100-mesh Pt gauze material was used.

[0023] In various embodiments, the electrolyte in the cathode compartment is charged with CO₂, e.g., by bubbling CO₂ into the electrolyte. The source of CO₂ may include CO₂ in waste gases of an industrial plant such as the flue gas of a fossil fuelled electrical power generating plant. In various embodiments, the system includes a gas mixer/gas absorber that enhances the absorption of CO₂ in the cathode electrolyte. In one embodiment, the gas mixer/gas absorber comprised a series of spray nozzles that produced a flat sheet or curtain of liquid through which the gas was directed for absorption; in another embodiment the gas mixer/gas absorber comprised spray absorber that created a mist into which the gas was directed for absorption; other commercially available gas/liquid absorber e.g., an absorber available from Neumann Systems, Colorado, USA may be used. In operation, the cathode and anode compartments are filled with electrolytes and a voltage is applied across the cathode and anode. In various embodiments, the voltage is adjusted to a level to cause production of hydrogen gas at the cathode without producing a gas, e.g., chlorine or oxygen, at the anode. In various embodiments, the system includes a cathode and an anode that facilitate reactions whereby the cathode electrolyte is enriched with hydroxide ions and the anode electrolyte is enriched with hydrogen ions.

[0024] Reduction of water at the cathode produces hydroxide ions that migrate into the cathode electrolyte. The production of hydroxide ions in the cathode electrolyte surrounding the cathode may elevate the pH of the cathode electrolyte. In various embodiments, the solution with the elevated pH is used in situ, or is drawn off and utilized in a separate reaction, e.g., to sequester CO₂ as described therein. Depending on the balance of the rate of hydroxide ion production versus the rate of carbon dioxide absorption in the cathode electrolyte, it is possible for the pH to remain the same or even decrease, as hydroxide ions are consumed in reaction with protons from dissociation of carbonic acid into carbonate and bicarbonate ions.

[0025] Oxidation of hydrogen gas at the anode results in production of hydrogen ions at the anode that desorb from the structure of the anode and migrate into the electrolyte surrounding the anode, resulting in a lowering of the pH of the anode electrolyte. Thus, the pH of the electrolytes in the system can be adjusted by controlling the voltage across the cathode and anode and using electrodes comprised of a material capable of absorbing or desorbing hydrogen ions. In various embodiments, the process generates hydroxide ions in

solution with less than a 1:1 ratio of CO₂ molecules released into the environment per hydroxide ion generated.

[0026] In various embodiments, the system includes an inlet system configured to deliver carbon dioxide gas into the first cathode electrolyte compartment; the carbon dioxide includes carbon dioxide from waste gases of fossil fuelled electrical power generating plants, cement plants and the like. In various embodiments, the carbon dioxide gas delivered to the inlet system may comprise other gases, e.g., oxides of nitrogen (nitrous oxide, nitric oxide) and sulfur gases (sulfur dioxide, hydrogen sulfide); in various embodiments, the system includes a gas treatment system that is capable of removing constituents in the carbon dioxide gas before the gas is utilized in the cathode compartment.

[0027] As disclosed in U.S. Provisional Patent Application No. 61/091,729 filed August 25, 2008, titled: "Low Energy Absorption of Hydrogen Ion from an Electrolyte Solution into a Solid Material", and available on the USPTO Public Pair website, the present method in one embodiment pertains to a low-energy absorption of hydrogen ions from an electrolytic fluid into a solid material. In some embodiments, a hydrogen ion transfer element is configured to transfer hydrogen ions between the cathode electrolyte and anode electrolytes in the system. In various embodiments, the process pertains to removal of protons from bicarbonate ions or carbonic acid in the cathode electrolyte. In various embodiments, hydrogen ions are transferred from one electrolyte solution to another using a hydrogen transfer element that includes a hydrogen storage material such as a palladium membrane, foil, or film. In various embodiments, hydrogen ions are obtained from a proton donor, e.g., carbonic acid, bicarbonate ion, water, and the like and are transferred to a second electrolyte solution. In various embodiments, hydrogen ions and/or carbonate ions are produced by contacting an electrolyte solution with CO₂ to remove protons from bicarbonate ions present in the solution. In various embodiments, transferring the hydrogen ions to a second electrolyte solution while contacting a first electrolyte solution with CO₂ allows for a greater concentration of bicarbonate ions in the first electrolyte solution.

[0028] In various embodiments, the anode electrolyte, enriched with hydrogen ions, can be utilized for a variety of applications including dissolving minerals to produce a solution of divalent cations for use in sequestering carbon dioxide. In various embodiments, the electrolytic cell includes a cathode and/or an anode capable of facilitating reactions to remove hydrogen ions from an electrolytic fluid from a donor molecule in an electrolytic fluid, e.g., to enrich a solution with hydroxide ions or hydrogen ions, where donor molecules of interest include carbonic acid, bicarbonate ions, water, and the like.

[0029] The absorption of hydrogen ions from a solution into the structure of a cathode produces an excess of hydroxide ions in the solution surrounding the cathode. In various embodiments, the cathode electrolyte can be used *in situ*, or drawn off and to utilized in a separate reaction, for a variety of purposes, including the sequestration of CO₂ as described therein. In various embodiments, the hydrogen ions can be desorbed from the structure when arranged as an anode to produce excess hydrogen ions in a solution in contact with the anode to lower the pH of the solution.

[0030] In some embodiments, the electrolyte solution in a half-cell is charged with ionized forms of CO₂ for example, by bubbling CO₂ from a source into the electrolyte solution. Ionized forms of CO₂ include bicarbonate ions (HCO₃⁻) and carbonate ions (CO₃⁻²). The source of carbon dioxide can be, for instance, a

waste feed from an industrial plant such as flue gas from a fossil fuelled electrical power generating plant or a cement plant. The CO₂ can be introduced into the electrolyte solution with a sparger, in some embodiments, or by contact with an aqueous liquid spray. In some systems, the reservoir can be enriched with bicarbonate and/or carbonate ions by introducing CO₂ gas into the reservoir as hydrogen is removed. In some systems, an electrolyte solution within a reservoir can be flushed to prevent a build-up of hydrogen ions within the reservoir that would oppose the continued transfer of hydrogen ions between the two reservoirs. In some embodiments, the voltage applied across the anode and the cathode is less than 1.24 volts or less than 1.0 volt. The half-cell can include a mixer to help the CO₂ absorb and dissolve into the electrolyte solution. In various embodiments, a conductive electrolyte solution can be employed as the electrolyte solution within the reservoir and in some embodiments the electrolyte solution comprises seawater, brine, or brackish water.

[0031] As disclosed herein, in various embodiments, hydroxide ions are produced in the cathode electrolyte in a first cathode electrolyte compartment by applying a relatively low voltage, e.g., less than 3V, such as less than 2V, or less than 1V or less than 0.8V or less than 0.6V or less than 0.4V across the cathode and anode while dissolving carbon dioxide in the cathode electrolyte in a second cathode electrolyte compartment. In various embodiments, hydroxide ions are produced from water in the cathode electrolyte in contact with the cathode, and bicarbonate ions and/or carbonate ions are produced in the cathode electrolyte in the first cathode electrolyte compartment by dissolving carbon dioxide gas in the cathode electrolyte in the first cathode electrolyte compartment.

[0032] In various embodiments, cathode electrolyte in the first cathode electrolyte compartment is in contact with the cathode electrolyte in the second cathode electrolyte compartment. The cathode electrolyte in the first cathode electrolyte compartment may comprise a gas or a gas dissolved in the cathode electrolyte. For example, the carbon dioxide is present as carbon dioxide gas and/or as dissolved carbon dioxide in the cathode electrolyte. In various embodiments, the carbon dioxide gas is isolated from cathode electrolyte in the second cathode electrolyte compartment.

[0033] In various embodiments, the cathode electrolyte in the first cathode electrolyte compartment comprises hydroxide ions, carbonic acid, carbonate ions and/or bicarbonate ions. Similarly, the cathode electrolyte in the second cathode electrolyte compartment comprises dissolved carbon dioxide. In other embodiments, the cathode electrolyte in the second cathode electrolyte compartment comprises hydroxide ions, carbonic acid, carbonate ions and/or bicarbonate ions.

[0034] In various embodiments, the system is configured to produce hydroxide ions in the second cathode electrolyte compartment with less than 2V applied across the anode and cathode. The system is also configured to produce hydrogen gas at the cathode. In various embodiments, the system does not produce a gas at the anode; the system, however, is configured to migrate hydroxide ions from the second cathode electrolyte compartment to the first cathode electrolyte compartment. In other embodiments, the system comprises a hydrogen gas delivery system configured to direct hydrogen gas produced at the cathode to the anode. In one embodiment, the first cathode electrolyte compartment is operatively connected to an industrial waste gas system that comprises carbon dioxide. In various embodiments, the carbon dioxide is derived from combusting fossil fuels.

[0035] In other embodiments, the cathode compartment is operatively connected to a waste gas treatment system, wherein the waste gas system comprises carbon dioxide. In other embodiments, the cathode compartment is operatively connected to a hydroxide, carbonate and/or bicarbonate precipitation system. In various embodiments, the precipitation system is configured to utilize the cathode electrolyte to produce hydroxide, carbonates and/or divalent cation bicarbonates. In various embodiments, the anode and cathode are operatively connected to an off-peak electrical power-supply system.

[0036] In various embodiments, the system comprises an ion exchange membrane located between the anode compartment and the cathode compartment. In various embodiments, the ion exchange membranes comprise a cation exchange membrane separating the cathode electrolyte in the second cathode electrolyte compartment from a third electrolyte. In various embodiments, the ion exchange membrane comprises an anion exchange membrane separating the anode electrolyte from the third electrolyte.

[0037] In various embodiments, the third electrolyte comprises sodium ions and chloride ions; the system is configured to migrate sodium ions from the third electrolyte to cathode electrolyte through the cation exchange membrane, and migrate chloride ions from the third electrolyte to the anode electrolyte through the anion exchange membrane.

[0038] In various embodiments, the system is configured to produce sodium hydroxide in the cathode electrolyte; and the system is also configured to produce sodium hydroxide, sodium carbonate and/or sodium bicarbonate in the cathode electrolyte. In various embodiments, the system is configured to produce partially desalinated water in the third electrolyte; and the partially desalinated water is operatively connected to a water treatment system. In other embodiments, the cathode electrolyte is operatively connected to a first carbon dioxide gas/liquid contactor configured to dissolve carbon dioxide in the cathode electrolyte; the system is configured to produce a pH differential of between 0 and 14 or greater pH units between the anode and cathode electrolytes.

[0039] In various embodiments, by the method, hydroxide ions, carbonic acid, carbonates ions and/or bicarbonate ions are produced in the first cathode electrolyte compartment; and carbonate ions and/or bicarbonate ions are produced in the second cathode electrolyte compartment. In various embodiments, hydrogen gas is produced at the cathode and hydrogen ions are produced at the anode.

[0040] In various embodiments, by the method, a gas is not produced at the anode; however, hydrogen gas is produced at the cathode and in some embodiments is directed to the anode. In various embodiments, the voltage across the anode and cathode is less than 2V. By the method, sodium ions are migrated from the third electrolyte to the cathode electrolyte across the cation exchange membrane, and chloride ions are migrated from the third electrolyte to the anode electrolyte across the anion exchange membrane. By the method, sodium carbonate, sodium bicarbonate or sodium hydroxides are produced in the cathode electrolyte, and hydrochloric acid is produced in the anode electrolyte. By the method, acid produced in the anode electrolyte is utilized to dissolve a mafic mineral and/or a cellulose material.

[0041] By the method, partially desalinated water is produced in the third electrolyte. In one embodiment, divalent cation hydroxide, carbonate and/or bicarbonate compounds are produced by contacting the cathode electrolyte with a solution comprising divalent cations, e.g., calcium and magnesium ions. In one embodiment,

the method includes a step of withdrawing a first portion of the cathode electrolyte; dissolving carbon dioxide in the first portion of cathode electrolyte to produce a first enriched carbonated cathode electrolyte; and replenishing cathode electrolyte with the first enriched carbonated cathode electrolyte. In other embodiments, the method comprises the steps of withdrawing a second portion of the cathode electrolyte; dissolving carbon dioxide in the second portion of cathode electrolyte to produce a second enriched carbonated cathode electrolyte; and contacting the second enriched carbonated cathode electrolyte with a divalent cation solution to produce divalent cation carbonates. In various embodiments, the method includes applying an off-peak electrical power-supply across the cathode and anode to provide the voltage across the anode and cathode.

[0042] By the system and method, hydrogen gas is produced at the cathode from water in the cathode electrolyte. In various embodiments, a gas, e.g., oxygen or chlorine is not produced at the anode; in various embodiments, hydrogen gas from an external source is provided to the anode where it is oxidized to hydrogen ions that migrate into the anode electrolyte to produce an acid in the anode electrolyte.

[0043] In various embodiments, hydroxide ions produced at the cathode in the second cathode electrolyte compartment migrate into the cathode electrolyte and may cause the pH of the cathode electrolyte to adjust, e.g., the pH of the cathode electrolyte may increase, decrease or remain the same, depending on the rate of removal of cathode electrolyte from the system. In various embodiments, depending on the pH of the cathode electrolyte and the rate of dissolution of carbon dioxide in the first cathode electrolyte compartment, carbon dioxide gas in contact with cathode electrolyte in the first cathode compartment will dissolve in the cathode electrolyte to produce carbonic acid which may dissociate to bicarbonate and/or carbonate ions in the cathode electrolyte, depending on the pH of the cathode electrolyte. Thus, in various embodiments, since the cathode electrolyte in the first and second cathode electrolyte compartment can intermix, the cathode electrolyte may contain carbonic acid, hydroxide ions and/or carbonate ions and/or bicarbonate ions.

[0044] In various embodiments, the system includes a hydrogen gas transfer system configured to direct hydrogen gas to the anode where the hydrogen gas is oxidized, without intermixing the hydrogen gas with carbon dioxide present in the cathode electrolyte compartment. In various embodiments, the hydrogen gas produced at the cathode is directed to the anode for oxidation to hydrogen ions.

[0045] In various embodiments, a portion of or the entire amount of cathode electrolyte comprising bicarbonate ions and/or carbonate ions/ and or hydroxide ions is withdrawn from the system via an outflow stream. In some embodiments, a portion of the withdrawn cathode electrolyte is contacted with carbon dioxide gas in an exogenous carbon dioxide gas/liquid contactor to increase the absorbed carbon dioxide content in the electrolyte solution. In some embodiments, the solution with the absorbed carbon dioxide is returned to the cathode compartment; in other embodiments, the solution with the absorbed carbon dioxide is reacted with a solution comprising divalent cations to produce divalent cation hydroxides, carbonates and/or bicarbonates. In various embodiments, the system and method are configurable for batch, semi-batch or continuous flow operation.

[0046] In various embodiments, industrial waste gas containing carbon dioxide is utilized to produce carbonate and bicarbonate ions in the cathode electrolyte. In some embodiments, carbon dioxide is prevented

from mixing with other gases in the system, e.g., with hydrogen gas generated at the cathode or with hydrogen gas oxidized at the anode. In other embodiments, carbon dioxide gas is prevented from contacting the cathode and/or anode.

[0047] In various embodiments, the pH of the cathode electrolyte is adjusted by producing hydroxide ions from water at the cathode, and allowing the hydroxide ions to migrate into the cathode electrolyte. The pH is also adjusted by dissolving carbon dioxide gas in the cathode electrolyte to produce carbonic acid and carbonic ion species in the electrolyte that react with the hydroxide ions to produce carbonate ions, or bicarbonate ions, or only carbonate ions, or only bicarbonate ions, or mixtures thereof.

[0048] With reference to Figs. 1 - 3, the system 100, 200, 300 in various embodiments comprises a cathode compartment 102 partitioned into a first cathode electrolyte compartment 104 and a second cathode electrolyte compartment 106 wherein, cathode electrolyte 108 in the second cathode electrolyte compartment is in contact with a cathode 110; and wherein anode electrolyte 115 in an anode compartment 112 is in contact with an anode 114. As is illustrated in Figs. 1-3, the system includes partition 103 that partitions the cathode compartment 102 into the first cathode electrolyte compartment 104 and the second cathode electrolyte compartment 106 such that on placing electrolyte in the cathode compartment, liquid flow between the cathode electrolyte in the first cathode electrolyte compartment 104 and cathode electrolyte in the second cathode electrolyte compartments 106 is possible. In various embodiments, initially the cathode electrolytes comprise an aqueous salt solution e.g., sodium hydroxide, prepared by dissolving the salt in a water-based solvent, e.g., an acceptably clean fresh water, salt water, brackish water, seawater, man-made saltwater and the like.

[0049] As is illustrated in a cross-section view in Figs. 1-3, a partition 103 is configured in an approximate J-shape structure and is positioned in the first cathode electrolyte compartment 104 to define an upward-tapering channel 105 in the first cathode compartment between the partition 103 and a sidewall 111 of the cathode electrolyte compartment. Partition 103 also defines a downward-tapering channel 107 in the first cathode electrolyte compartment between the partitioning member and a bottom wall 113 of the cathode electrolyte compartment.

[0050] In positioning partition 103 in the cathode compartment 102, cathode electrolyte in the cathode compartment is partitioned into the first cathode electrolyte compartment 104 and the second cathode electrolyte compartment 106. In various embodiments, partition 103 is configured such that cathode electrolyte in cathode compartment 102 can flow between the first and second electrolyte compartments; however, partition 103 is also configured such that a gas in the first electrolyte compartment 104 is prevented from mixing with other fluids in the system when cathode electrolyte is present in the cathode compartment 102, at least at a depth that the liquid seals the passageway between the downward-tapering channel 107 in the first cathode electrolyte compartment 104 and the second cathode electrolyte compartment 106.

[0051] With reference to Fig. 1, on introducing carbon dioxide gas 109A, in a lower portion of the first cathode electrolyte compartment 104 with cathode electrolyte present, a portion of the gas may dissolve in the cathode electrolyte while un-dissolved gas being less dense than the electrolyte will bubble upward in upward-tapering channel 105 in the first cathode electrolyte compartment from where it may be vented as

vent gas 109B. In some embodiments not shown, the vent gas 109B is recovered and reused as input carbon dioxide gas 109A.

[0052] With reference to Figs. 1-3, depending on the pH of the cathode electrolyte, carbon dioxide gas 109A introduced into the first cathode electrolyte compartment 104 will dissolve in the cathode electrolyte in the first cathode electrolyte compartment 104 and reversibly dissociate and equilibrate to produce carbonic acid, protons, carbonate and/or bicarbonate ions in the first cathode electrolyte compartment as follows:



As cathode electrolyte in the first cathode electrolyte compartment 104 may mix with cathode electrolyte in the second cathode electrolyte compartment 106 and vice versa, carbonic acid, bicarbonate and carbonate ions formed in the first cathode electrolyte compartment 104 by absorption of carbon dioxide in the cathode electrolyte may migrate and equilibrate with cathode electrolyte in the second cathode electrolyte compartment 106. Thus, in various embodiments, cathode electrolyte in the first cathode electrolyte compartment may comprise dissolved and un-dissolved carbon dioxide gas, and/or carbonic acid, and/or bicarbonate ions and/or carbonate ions; while cathode electrolyte in the second cathode electrolyte compartment may comprise dissolved carbon dioxide, and/or carbonic acid, and/or bicarbonate ions and/or carbonate ions.

[0053] Also with reference to Figs. 1-3, on applying a voltage across the anode 114 and cathode 110, the system 100, 200, 300 in the cathode compartment 102 will produce hydroxide ions in the cathode electrolyte in the second cathode electrolyte compartment 106 and hydrogen gas at the cathode 110 from reduction of water, as follows:



As cathode electrolyte in the first cathode electrolyte compartment can intermix with cathode electrolyte in the second cathode electrolyte compartment, hydroxide ions formed in the second cathode electrolyte compartment may migrate and equilibrate with carbonate and bicarbonate ions in the second cathode electrolyte compartment 106. Thus, in various embodiments, the cathode electrolyte in the first cathode electrolyte compartment may comprise hydroxide ions as well as dissolved and un-dissolved carbon dioxide gas, and/or carbonic acid, and/or bicarbonate ions and/or carbonate ions; while cathode electrolyte in the second cathode electrolyte compartment may comprise hydroxide ions as well as dissolved carbon dioxide, and/or carbonic acid, and/or bicarbonate ions and/or carbonate ions.

[0054] In the cathode electrolyte, carbon dioxide gas may dissolve to form carbonic acid, protons, bicarbonate ions, and carbonate ions, depending on the pH of the electrolyte, as follows:



As the solubility of carbon dioxide and the concentration of bicarbonate and carbonate ions in the cathode electrolyte are dependent on the pH of the electrolyte, the overall reaction in the first cathode electrolyte compartment 102 (i.e., the first cathode electrolyte compartment 104 and the second cathode electrolyte compartment 106) is either:

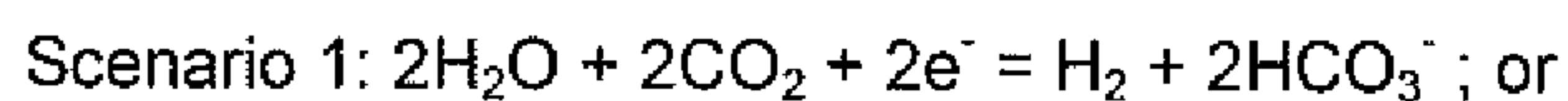

or a combination of both, depending on the pH of the cathode electrolyte, as illustrated in Fig. 6

5 [0055] For either scenario, the overall cell potential of the system can be determined through the Gibbs energy change of the reaction by the formula:

$$E_{\text{cell}} = -\Delta G/nF$$

Or, at standard temperature and pressure conditions:

$$E^{\circ}_{\text{cell}} = -\Delta G^{\circ}/nF$$

10 where, E_{cell} is the cell voltage, ΔG is the Gibbs energy of reaction, n is the number of electrons transferred, and F is the Faraday constant (96485 J/Vmol). The E_{cell} of each of these reactions is pH dependent based on the Nernst equation as demonstrated for Scenario 1, (see Fig. 7).

[0056] Also, for either scenario, the overall cell potential can be determined through the combination of Nernst equations for each half cell reaction:

$$E = E^{\circ} - R T \ln(Q) / n F$$

5 where, E° is the standard reduction potential, R is the universal gas constant, (8.314 J/mol K) T is the absolute temperature, n is the number of electrons involved in the half cell reaction, F is Faraday's constant (96485 J/V mol), and Q is the reaction quotient such that:

$$E_{\text{total}} = E_{\text{cathode}} + E_{\text{anode}}$$

When hydrogen is oxidized to protons at the anode as follows:



E° is 0.00 V, n is 2, and Q is the square of the activity of H^+ so that:

$$E_{\text{anode}} = +0.059 \text{ pH}_a,$$

where pH_a is the pH of the anode electrolyte.

When water is reduced to hydroxide ions and hydrogen gas at the cathode as follows:



E° is -0.83 V, n is 2, and Q is the square of the activity of OH^- so that:

$$E_{\text{cathode}} = -0.059 \text{ pH}_c,$$

where pH_c is the pH of the cathode electrolyte.

20 **[0057]** For either Scenario, the E for the cathode and anode reactions varies with the pH of the anode and cathode electrolytes. Thus, for Scenario 1 if the anode reaction, which is occurring in an acidic environment, is at a pH of 0, then the E of the reaction is 0V for the half cell reaction. For the cathode

reaction, if the generation of bicarbonate ions occur at a pH of 7, then the theoretical E is $7 \times (-0.059 \text{ V}) = -0.413\text{V}$ for the half cell reaction where a negative E means energy is needed to be input into the half cell or full cell for the reaction to proceed. Thus, if the anode pH is 0 and the cathode pH is 7 then the overall cell potential would be -0.413V , where:

$$E_{\text{total}} = -0.059 (\text{pH}_a - \text{pH}_c) = -0.059 \Delta\text{pH}.$$

[0058] For Scenario 2 in which carbonate ions are produced, if the anode pH is 0 and the cathode pH is 10, this would represent an E of 0.59 V.

[0059] Thus, in various embodiments, directing CO_2 gas 109A into the cathode electrolyte may lower the pH of the cathode electrolyte by producing bicarbonate ions and/or carbonate ions in the cathode electrolyte, and also lower the voltage across the anode and cathode to produce hydroxide, carbonate and/or bicarbonate in the cathode electrolyte.

[0060] Thus, as can be appreciated, if the cathode electrolyte is allowed to increase to a pH of 14 or greater, the difference between the anode half-cell potential (represented as the thin dashed horizontal line, Scenario 1, above) and the cathode half cell potential (represented as the thick solid sloping line in Scenario 1, above) will increase to 0.83V. With increased duration of cell operation without CO_2 addition or other intervention, e.g., diluting with water, the required cell potential will continue to increase. The cell potential may also increase due to ohmic resistance losses across the membranes in the electrolyte and the cell's overvoltage potential.

[0061] Herein, overvoltage potential refers to the potential (voltage) difference between a half-reaction's thermodynamically determined reduction potential and the potential at which the redox event is experimentally observed. The term is directly related to a cell's voltage efficiency. In an electrolytic cell the overvoltage potential requires more energy than thermodynamically expected to drive a reaction. In each case, the extra or missing energy is lost as heat. Overvoltage potential is specific to each cell design and will vary between cells and operational conditions even for the same reaction. It can thus be appreciated that operation of the electrochemical cell with the cathode pH at 7 or greater provides a significant energy savings.

[0062] In various embodiments, for different pH values in the cathode electrolyte and the anode electrolyte, hydroxide ions, carbonate ions and/or bicarbonate ions are produced in the cathode electrolyte when the voltage applied across the anode and cathode was less than 3V, 2.9V, 2.8V, 2.7V, 2.6V, 2.5V, 2.4V, 2.3V, 2.2V, 2.1V, 2.0V, 1.9V, 1.8V, 1.7V, 1.6V, 1.5V, 1.4V, 1.3V, 1.2V, 1.1V, 1.0V, 0.9V, 0.8V, 0.7V, 0.6V, 0.5V, 0.4V, 0.3V, 0.2V, or 0.1V. For selected voltages in the above range, the pH difference between the anode electrolyte and the cathode electrolyte was 0, 1, 2, 3, 4, 5, 6, 7, 8, 9, 10, 11, 12, 13, 14 or greater.

[0063] Also, in embodiments wherein it is desired to produce bicarbonate and/or carbonate ions in the cathode electrolyte, the system as illustrated in Figs. 1-3, and as described above with reference to production of hydroxide ions in the cathode electrolyte, can be configured to produce bicarbonate ions and/or carbonate ions in the first cathode electrolyte by dissolving carbon dioxide in the first cathode electrolyte and applying a voltage of less than 3V, or less than 2.5 V, or less than 2V, or less than 1.5V such as less than 1.0V, or even less than 0.8 V or 0.6V across the cathode and anode.

[0064] In some embodiment as illustrated in Figs. 1-3, the system includes a cation exchange membrane 120 that separates the cathode electrolyte in the second cathode electrolyte compartment 106 from a third electrolyte 122, and an anion exchange membrane 124 that separates anode electrolyte 115 in contact with an anode 114 from the third electrolyte 122. As can be appreciated, since a cation exchange membrane will prevent migration of anions across the cation exchange membrane, therefore hydroxide ions and/ or carbonate ions and/or bicarbonate in the second cathode electrolyte compartment 106 will not migrate to the adjacent third electrolyte 122 through the first cation exchange membrane 120. Thus, in the system, the hydroxide ions and/or carbonate ions and/or bicarbonate ions will accumulate in the cathode electrolyte 108, or can be drawn off and use to sequester carbon dioxide as described in U.S. Provisional Patent Application no. 61/081,299 filed July 16, 2008, supra.

[0065] With reference to Fig. 1, where the third electrolyte 122 comprises a dissolved salt, e.g., sodium chloride, since a cation exchange membrane will allow migration of cations through the cation exchange membrane, therefore cations, e.g., sodium ions in the third electrolyte 122 will migrate across cation exchange membrane 120 from the third electrolyte 122 to the cathode electrolyte in the second cathode electrolyte compartment 106, on application of a voltage across the cathode 110 and anode 114. In the cathode compartment 102 sodium ions together with hydroxide ions present in the cathode electrolyte and carbonate ions from dissolved carbon dioxide will produce a sodium salt solution, e.g., sodium hydroxide, and/or sodium carbonate, and/or sodium bicarbonate solution.

[0066] Similarly with reference to Fig. 1, since an anion exchange membrane will allow migration of anions through the anion exchange membrane, therefore anions, e.g., chloride ions in the third electrolyte 122 will migrate across the anion exchange membrane 124 from the third electrolyte to the anode electrolyte 115, on application of a voltage across the cathode 110 and anode 114. In the anode electrolyte, chloride ions together with protons present in the anode electrolyte 115 will form an acid, e.g., hydrochloric acid. Consequently, as can be appreciated, since cations and anions migrate out of the third cathode electrolyte 122, the system will produce partially desalinated water from the third electrolyte 122.

[0067] In various embodiments, hydroxide ions, carbonate ions and/or bicarbonate ions produced in the cathode electrolyte, and hydrochloric acid produced in the anode electrolyzed are removed from the system, while sodium chloride in the third electrolyte is replenished to maintain continuous operation of the system.

[0068] As can be appreciated by one skilled in the art, in various embodiments, the system can be configured to operate in various production modes including batch mode, semi-batch mode, continuous flow mode, with or without the option to withdraw portions of the sodium hydroxide produced in the cathode electrolyte, or withdraw all or a portions of the acid produced in the anode electrolyte, or direct the hydrogen gas produced at the cathode to the anode where it may be oxidized.

[0069] In various embodiments, hydroxide ions, bicarbonate ions and/or carbonate ion solutions are produced in the cathode electrolyte when the voltage applied across the anode and cathode is less than 3V, 2.9V or less, 2.8V or less, 2.7V or less, 2.6V or less, 2.5V or less, 2.4V or less, 2.3V or less, 2.2V or less, 2.1V or less, 2.0V or less, 1.9V or less, 1.8V or less, 1.7V or less, 1.6V, or less 1.5V or less, 1.4V or less,

1.3V or less, 1.2V or less, 1.1V or less, 1.0V or less, 0.9V or less or less, 0.8V or less, 0.7V or less, 0.6V or less, 0.5V or less, 0.4V or less, 0.3V or less, 0.2V or less, or 0.1 V or less.

5 **[0070]** In another embodiment, the voltage across the anode and cathode can be adjusted such that gas will form at the anode, e.g., oxygen or chlorine, while hydroxide ions, carbonate ions and bicarbonate ions are produced in the cathode electrolyte and hydrogen gas is generated at the cathode. However, in this embodiment, hydrogen gas is not supplied to the anode. As can be appreciated by one ordinarily skilled in the art, in this embodiment, the voltage across the anode and cathode will be higher compared to the embodiment when a gas does not form at the anode.

10 **[0071]** With reference to Figs. 1 - 3, anion exchange membrane 114 and cation exchange membrane 120 can be conventional ion exchange membranes. Ideally, the membranes should be capable of functioning in an acidic and/or basic electrolytic solution and exhibit high ion selectivity, low ionic resistance, high burst strength, and high stability in an acidic electrolytic solution in a temperature range of 0°C to 100°C or higher. In some embodiments a membrane stable in the range of 0 °C to 80 °C, or 0 °C to 90 °C, but not stable above these ranges may be used. Suitable membranes include a Teflon™-based cation exchange membrane
15 available from Asahi Kasei of Tokyo, Japan. However, low cost hydrocarbon-based cation exchange membranes can also be utilized, e.g., the hydrocarbon-based membranes available from, e.g., Membrane International of Glen Rock, NJ, and USA.

[0072] In various embodiments, the cathode compartment 102 is operatively connected to a waste gas treatment system (not illustrated) where the base solution produced in the cathode electrolyte is utilized, e.g.,
20 to sequester carbon dioxide contained in the waste gas by contacting the waste gas and the cathode electrolyte with a solution of divalent cations to precipitate hydroxides, carbonates and/or bicarbonates as described in commonly assigned U.S. Patent Application no. 12/344,019 filed on December 24, 2008, (available on the Public Pairs website). The precipitates, comprising, e.g., calcium and magnesium hydroxides, carbonates and bicarbonates in various embodiments may be utilized as building materials, e.g.,
25 as cements and aggregates, as described in commonly assigned U.S. Patent Application no. 12/126,776 filed on May 23, 2008, supra, (available on the Public Pairs website). In some embodiments, some or all of the carbonates and/or bicarbonates are allowed to remain in an aqueous medium, e.g., a slurry or a suspension, and are disposed of in an aqueous medium, e.g., in the ocean depths.

[0073] In various embodiments, the cathode and anode are also operatively connected to an off-peak electrical power-supply system that supplies off-peak voltage to the electrodes. Since the cost of off-peak power is lower than the cost of power supplied during peak power-supply times, the system can utilize off-peak power to produce a base solution in the cathode electrolyte at a relatively lower cost.

[0074] In various embodiments, partially desalinated water is produced in the third electrolyte 122 as a result of migration of cations and anions from the third electrolyte to the adjacent anode electrolyte and
35 cathode electrolyte. In various embodiments, the partially desalinated water is operatively connected to a desalination system (not illustrated) where it is further desalinated as described in commonly assigned U.S. Patent Application no. 12/163,205 filed on June 27, 2008, (available on the USPTO Public Pair website).

[0075] In another embodiment, the system produces an acid, e.g., hydrochloric acid in the anode electrolyte. Thus, in various embodiments, the anode compartment is operably connected to a system for dissolving minerals and waste materials comprising divalent cations to produce a solution of divalent cations, e.g., Ca^{++} and Mg^{++} . In various embodiments, the divalent cation solution is utilized to precipitate hydroxides, carbonates and/or bicarbonates by contacting the divalent cation solution with the present base solution and a source of carbon dioxide gas as described in U.S. Patent Application no. 12/344,019 filed on December 24, 2008, supra, (available on the Public Pairs website). In various embodiments, the precipitates are used as building materials e.g., cement and aggregates as described in commonly assigned U.S. Patent application no. 12/126,776, supra, (available on the USPTO Public Pair website).

[0076] With reference to Figs. 2, in various embodiments, the system includes a cathode electrolyte circulating system 126 adapted for withdrawing and circulating cathode electrolyte in the system. In one embodiment, the cathode electrolyte circulating system comprises a first carbon dioxide gas/liquid contactor 128 that is adapted for dissolving carbon dioxide in the circulating cathode electrolyte, and for circulating the electrolyte in the system. In this embodiment, since sufficient carbon dioxide can be dissolved in the electrolyte in the gas/liquid contactor outside of the cathode electrolyte compartment, optionally it may not be necessary to introduce carbon dioxide 109 A in the cathode electrolyte as is illustrated in Fig. 1 and as described above.

[0077] In another embodiment as is illustrated in Fig. 3, the cathode electrolyte circulating system comprises a second carbon dioxide gas/liquid contactor 130 that is capable of dissolving carbon dioxide in a portion of the circulating cathode electrolyte 126 without returning this electrolyte to the cathode compartment. In this embodiment, the electrolyte can be used, e.g., in precipitating divalent cation carbonates and/or bicarbonates outside of the cathode compartment. Also, as can be appreciated, since the pH of the cathode electrolyte can be adjusted by withdrawing and/or circulating cathode electrolyte from the system, the pH of the cathode electrolyte compartment can be regulated by regulating the amount of electrolyte removed from the system through the second carbon dioxide gas/liquid contactor 130.

[0078] With reference to Figs. 1-3, systems 100, 200 and 300 in various embodiments include a hydrogen gas circulating system 118 adapted for circulating hydrogen gas generated at the cathode 110 for oxidation at the anode 114. In various embodiments, the hydrogen gas is operationally connected to an external supply of hydrogen (not shown) to provide hydrogen gas to the anode 114, e.g., at start-up of operations when the hydrogen supply from the cathode is insufficient.

[0079] In various embodiments, the system includes a cathode electrolyte withdrawal and replenishing system (not illustrated) capable of withdrawing all of, or a portion of, the cathode electrolyte from the cathode compartment 102. In various embodiments, the system also includes a salt solution supply system (not shown) for providing a salt solution, e.g., concentrated sodium chloride, as the third electrolyte 122. In various embodiments the system includes a gas supply system (not shown) for supplying carbon dioxide gas 109A to the cathode electrolyte. In various embodiments, the system also includes inlet ports (not shown) for introducing fluids into the cells and outlet ports (not shown) for removing fluids from the cells.

[0080] As can be appreciated, in various embodiments and with reference to Fig. 1, although the cathode electrolyte is separated from the third electrolyte by the first cation exchange membrane, and the third electrolyte is separated from the anode electrolyte, when a voltage is applied across the anode and cathode, anions in the electrolytes will attempt to migrate towards the anode 114, and cations will attempt to migrate towards the cathode 110 through the cation exchange membrane and the anion exchange membrane.

[0081] With reference to Fig. 1, on applying a voltage across the anode and cathode, protons will form at the anode from oxidation of hydrogen gas supplied to the anode, while hydroxide ions and hydrogen gas will form at the cathode electrolyte from the reduction of water, as follows:



[0082] Since protons are formed at the anode from hydrogen gas provided to the anode; and since a gas such as oxygen does not form at the anode; and since water in the cathode electrolyte forms hydroxide ions and hydrogen gas at the cathode, the system will produce hydroxide ions in the cathode electrolyte and protons in the anode electrolyte when a voltage is applied across the anode and cathode.

[0083] Further, as can be appreciated, in the present system since a gas does not form at the anode, the system will produce hydroxide ions in the cathode electrolyte and hydrogen gas at the cathode and hydrogen ions at the anode when less than 2V is applied across the anode and cathode, in contrast to the higher voltage that is required when a gas is generated at the anode, e.g., chlorine or oxygen. For example, in various embodiments, hydroxide ions are produced when less than 2.0V, 1.5V, 1.4V, 1.3V, 1.2V, 1.1V, 1.0V, 0.9V, 0.8V, 0.7V, 0.6V, 0.5V, 0.4V, 0.3V, 0.2V, 0.1 V or less is applied across the anode and cathode.

[0084] With reference to Fig. 1, on applying a voltage across the anode and cathode, the positively charged protons formed at the anode will attempt to migrate to the cathode through the anode electrolyte, while the negatively charged hydroxide ions formed at the cathode will attempt to migrate to the anode through the cathode electrolyte. As is illustrated in Fig. 1 and with reference to the hydroxide ions in the cathode electrolyte, since the first cation exchange membrane will contain the cathode electrolyte within the cathode compartment, and since the cation exchange membrane will prevent the migration of anions from the cathode electrolyte to the third electrolyte, the hydroxide ions generated in the cathode electrolyte will be prevented from migrating out of the cathode electrolyte through the cation exchange membrane.

Consequently, on applying the voltage across the anode and cathode, the hydroxide ions produced at the cathode will be contained in the cathode electrolyte. Thus, depending on the flow rate of fluids into and out of the cathode electrolyte and the rate of carbon dioxide dissolution in the cathode electrolyte, the pH of the cathode electrolyte will adjust, e.g., the pH may increase, decrease or remain the same.

[0085] Similarly with reference to protons generated at the anode, under the applied voltage across the cathode and anode, the protons will enter the anode electrolyte and migrate to the anion exchange membrane. However, since the anion exchange membrane will block the movement of cations from the

anode electrolyte to the third electrolyte, protons in the anode electrolyte will be prevented from migrating to the third electrolyte. Consequently, on applying the voltage across the anode and cathode, the protons produced at the anode will be contained in the anode electrolyte. Thus, depending on the flow rate of fluids into and out of the anode electrolyte the pH of the anode electrolyte will adjust, e.g., the pH may increase, decrease or remain the same.

[0086] With reference to the third electrolyte initially charged with a concentrated solution of sodium ion and chloride ions and is contained in an electrochemical cell by the anion exchange membrane and the cation exchange membrane, on applying a voltage across the anode and cathode, anions in the third electrolyte, e.g., chloride ions, will migrate to the anode, while cations, e.g., sodium ions in the third electrolyte, will migrate to the cathode. Since the anion exchange membrane will allow the migration of anions from the third electrolyte to the anode electrolyte, chloride ions present in the third electrolyte will migrate to the anode electrolyte where they will form an acid, e.g., hydrochloric acid, with the protons from the anode.

[0087] Further, since the cation exchange membrane will allow migration of cations from the third electrolyte to the cathode electrolyte, sodium ions present in the third electrolyte will migrate to the cathode electrolyte where they will form sodium hydroxide with the hydroxide ions generated at the cathode. Consequently, as is illustrated in Fig. 1- 3, on application of a voltage across the anode and cathode, the cations, e.g., sodium ions, and anions, e.g., chloride ions will migrate out of the third electrolyte, thereby forming desalinated water in the third electrolyte.

[0088] In various embodiments and as is illustrated in Figs. 1 - 3, hydrogen gas is generated at the cathode from reduction of water in the cathode electrolyte. This gas can be vented from the cathode or directed to the anode where it is oxidized to protons as described herein.

[0089] In various embodiments, depending on the ionic species desired in the system, alternative reactants can be utilized. Thus, for example, if a potassium salt such as potassium hydroxide or potassium carbonate is desired in the cathode electrolyte, then a potassium salt such as potassium chloride can be utilized in the third electrolyte 122. Similarly, if sulphuric acid is desired in the anode electrolyte, then a sulphate such as sodium sulphate can be utilized in the third electrolyte 122. Likewise, as described in various embodiments herein, carbon dioxide gas is absorbed in the cathode electrolyte; however, it will be appreciated that other gases including volatile vapors can be absorbed in the electrolyte, e.g., sulfur dioxide, or organic vapors to produce a desired result. As can be appreciated, the gas can be added to the electrolyte in various ways, e.g., by bubbling it directly into the electrolyte, or dissolving the gas in a separate compartment connected to the cathode compartment and then directed to the cathode electrolyte as described herein.

[0090] With reference to Fig. 5, the method 500 comprises a step 502 of directing a gas into cathode electrolyte in a first cathode electrolyte compartment; and a step 504 of applying a voltage across a cathode in contact with cathode electrolyte in a second cathode electrolyte compartment, and an anode in contact with an anode electrolyte, where the first cathode electrolyte is partitioned from the second cathode electrolyte.

[0091] In various embodiments the method further includes a step of adding carbon dioxide to the cathode electrolyte; a step of producing carbonic acid, hydroxide ions, carbonate ions and/or bicarbonate ions

in the first cathode electrolyte compartment by applying a low voltage as described elsewhere herein, across the anode and cathode; a step of producing carbonate ions and/or bicarbonate ions in the second cathode electrolyte compartment; a step of producing hydrogen gas at the cathode and directing the gas to the anode where it is oxidized to hydrogen ions; a step of producing hydrogen ions at the anode; a step wherein a gas is not produced at the anode on applying the present voltage across the anode and cathode; a step wherein the voltage across the anode and cathode is less than 2V; a step of separating the cathode electrolyte from a third electrolyte by a cation exchange membrane; a step of separating the anode electrolyte from the third electrolyte by an anion exchange membrane; a step wherein the third electrolyte comprises sodium and chloride ions; a step of migrating sodium ions from the third electrolyte to the cathode electrolyte across the cation exchange membrane, and migrating chloride ions from the third electrolyte to the anode electrolyte across the anion exchange membrane; a step wherein the cathode electrolyte comprises sodium carbonate, sodium bicarbonate or sodium hydroxide, and the anode electrolyte comprises hydrochloric acid; a step of producing an acid in the anode electrolyte; a step of utilizing the acid to dissolve a mafic mineral or a cellulose materials; a step of producing partially desalinated water in the third electrolyte; a step comprising processing the partially desalinated water in a water desalination system; a step of contacting the cathode electrolyte with a divalent cation solution to produce divalent cation hydroxide, carbonate and/or bicarbonate compounds; a step wherein the divalent carbonate and/or bicarbonate compounds comprise calcium and magnesium; a step of withdrawing a first portion of the cathode electrolyte; dissolving carbon dioxide in the first portion of cathode electrolyte to produce a first enriched carbonated cathode electrolyte; and replenishing cathode electrolyte with the first enriched carbonated cathode electrolyte; a step of withdrawing a second portion of the cathode electrolyte; dissolving carbon dioxide in the second portion of cathode electrolyte to produce a second enriched carbonated cathode electrolyte; and contacting the second enriched carbonated cathode electrolyte with a divalent cation solution to produce divalent cation carbonates; a step of applying an off-peak electrical power-supply across the cathode and anode to provide the voltage across the anode and cathode.

[0092] In various embodiments, hydroxide ions are formed at the cathode and in the cathode electrolyte by applying a voltage of less than 2V across the anode and cathode without forming a gas at the anode, while providing hydrogen gas at the anode for oxidation at the anode. In various embodiments, method 500 does not form a gas at the anode when the voltage applied across the anode and cathode is less than 3V or less, 2.9V or less, 2.8V or less, 2.7V or less, 2.6V or less, 2.5V or less, 2.4V or less, 2.3V or less, 2.2V or less, 2.1V or less, 2.0V or less, 1.9V or less, 1.8V or less, 1.7V or less, 1.6V or less, 1.5V or less, 1.4V or less, 1.3V or less, 1.2V or less, 1.1V or less, 1.0V or less, 0.9V or less, 0.8V or less, 0.7V or less, 0.6V or less, 0.5V or less, 0.4V or less, 0.3V or less, 0.2V or less, or 0.1 V or less, while hydrogen gas is provided to the anode where it is oxidized to protons. As will be appreciated by one ordinarily skilled in the art, by not forming a gas at the anode and by providing hydrogen gas to the anode for oxidation at the anode, and by otherwise controlling the resistance in the system for example by decreasing the electrolyte path lengths and by selecting ionic membranes with low resistance and any other method know in the art, hydroxide ions can be produced in the cathode electrolyte with the present lower voltages.

[0093] In various embodiments, method 500 further comprises a step of directing carbon dioxide gas into the cathode electrolyte; a step of directing carbon dioxide gas into the cathode electrolyte before or after the cathode electrolyte is placed in contact with the cathode; a step of forming hydrogen gas at the cathode; a step of forming protons at the anode; a step of forming a pH differential of 1, 2, 3, 4, 5, 6, 7, 8, 9, 10, 11, 12, 13, 14 pH units or greater between the anode and cathode electrolytes without forming a gas at the anode by selectively applying a voltage of between 3V and 0.5V or less across the anode and the cathode; a step of forming hydroxide ions, bicarbonate ions, carbonate ions and/or a combination thereof in the cathode electrolyte; a step of forming sodium hydroxide, sodium bicarbonate or sodium carbonate in the cathode electrolyte; a step of migrating chloride ions from the third electrolyte across the anion exchange membrane to the anode electrolyte; a step of forming an acid in the anode electrolyte; a step of forming hydrochloric acid in the anode electrolyte; a step of migrating cations from the third electrolyte across a cation exchange membrane to the cathode electrolyte; a step of migrating sodium ions from the third electrolyte across the cation exchange membrane to the cathode electrolyte; a step of directing hydrogen gas formed at the cathode to the anode; and a step of removing cathode electrolyte via an outflow and replenishing cathode electrolyte via an inflow stream to the cathode electrolyte.

[0094] As will be appreciated by one ordinarily skilled in the art, by not forming a gas at the anode and by providing hydrogen gas to the anode for oxidation at the anode, hydroxide ions are produced in the cathode electrolyte with the present voltages. In various embodiments, method 500 in conjunction with the system of Figs. 1-3 further comprises a step of: e.g., applying a voltage across the anode 114 and cathode 110 such that a gas, oxygen or chlorine, is prevented from forming at the anode; a step of forming bicarbonate ions, carbonate ions or a mixture of bicarbonate and carbonate ions in the cathode electrolyte; a step of supplying and oxidizing hydrogen gas at the anode while applying a voltage of 3V, 2.9V, 2.8V, 2.7V, 2.6V, 2.5V, 2.4V, 2.3V, 2.2V, 2.1V, 2.0V, 1.9V, 1.8V, 1.7V, 1.6V, 1.5V, 1.4V, 1.3V, 1.2V, 1.1V, 1.0V, 0.9V, 0.8V, 0.7V, 0.6V, 0.5V, 0.4V, 0.3V, 0.2V, or 0.1 V or less across the cathode and anode and forming hydrogen gas at the cathode; a step of oxidizing hydrogen gas at the anode to form protons at the anode; a step of forming a pH differential of 1, 2, 3, 4, 5, 6, 7, 8, 9, 10, 11, 12, 13, 14 pH units or greater between the anode electrolyte and cathode electrolyte without forming a gas at the anode; a step of forming a pH gradient of pH differential of 1, 2, 3, 4, 5, 6, 7, 8, 9, 10, 11, 12, 13, 14 pH units or greater between the anode electrolyte and cathode electrolyte without forming a gas at the anode; a step of forming sodium carbonate, sodium bicarbonate or mixture of sodium carbonate and sodium bicarbonate in the cathode electrolyte; a step of migrating anions from the third electrolyte across the anion exchange membrane to the anode electrolyte; a step of migrating chloride ions from the third electrolyte across the anion exchange membrane to the anode electrolyte; a step of forming an acid in the anode electrolyte; a step of forming hydrochloric acid in the anode electrolyte; a step of migrating cations from the third electrolyte across the cation exchange membrane 120 to the cathode electrolyte; a step of migrating sodium ions from the third electrolyte across the cation exchange membrane to the cathode electrolyte; a step of directing hydrogen gas formed at the cathode 110 for oxidation at the anode 114; a step of directing at least a portion of the cathode electrolyte from an outflow to an inflow stream of the cathode electrolyte; a step of withdrawing a first portion of the cathode electrolyte,

dissolving carbon dioxide in the first portion of cathode electrolyte to produce a first enriched carbonated cathode electrolyte, and replenishing cathode electrolyte with the first enriched carbonated cathode electrolyte; and a step of withdrawing a second portion of the cathode electrolyte, dissolving carbon dioxide in the second portion of cathode electrolyte to produce a second enriched carbonated cathode electrolyte, and
5 contacting the second enriched carbonated cathode electrolyte with a divalent cation solution to produce divalent cation carbonates.

[0095] In various embodiments, bicarbonate ions and carbonate ions are produced in the cathode electrolyte where the voltage applied across the anode and cathode is less than 3.0V, 2.9V, 2.8V, 2.7V, 2.6V, 2.5V, 2.4V, 2.3V, 2.2V, 2.1V, 2.0V, 1.9V, 1.8V, 1.7V, 1.6V, 1.5V, 1.4V, 1.3V, 1.2V, 1.1V, 1.0V, 0.9V, 0.8V,
10 0.7V, 0.6V, 0.5V, 0.4V, 0.3V, 0.2V, 0.1V or less without forming a gas at the anode. In various embodiments, the method is adapted to withdraw and replenish at least a portion of the cathode electrolyte and the acid in the anode electrolyte back into the system in either a batch, semi-batch or continuous mode of operation.

[0096] With reference to Figs. 1-3, when a voltage is applied across the anode and cathode hydroxide ions and/or carbonate and/or bicarbonate ions will form in the in the cathode electrolyte and, consequently the
15 pH of the cathode electrolyte to be adjusted. In one embodiment, the anode and cathode hydroxide ions and/or carbonate and/or bicarbonate ions will form when a voltage across the cathode and anode is 0.1V or less, 0.2V or less, 0.4V or less, 0.6V or less, 0.8V or less, 1.0V or less, 1.5V or less, or 2.0V or less. For example, when a voltage of 0.8V or less is applied across the anode and cathode, hydroxide ions are produced in the cathode electrolyte solution; in another embodiment, when a voltage of 0.01 to 2.5 V, or
20 0.01V to 2.0V, or 0.1V to 2.0V, or 0.1 to 2.0 V, or 0.1V to 1.5V, or 0.1 V to 1.0V, or 0.1V to 0.8V, or 0.1V to 0.6V, or 0.1V to 0.4V, or 0.1V to 0.2V, or 0.01V to 1.5V, or 0.01 V to 1.0V, or 0.01V to 0.8V, or 0.01V to 0.6V, or 0.01V to 0.4V, or 0.01V to 0.2V, or 0.01V to 0.1V, e.g., or 0.1V to 2.0V is applied across the anode and cathode hydroxide ions are produced in the cathode electrolyte; in yet another embodiment, when a voltage of about 0.1V to 1V is applied across the anode and cathode hydroxide ions are produced in the cathode
25 electrolyte solution increased. Similar results are achievable with voltages of 0.1V to 0.8 V; 0.1V to 0.7 V; 0.1 to 0.6 V; 0.1V to 0.5 V; 0.1V to 0.4 V; and 0.1V to 0.3 V across the electrodes.

[0097] In various embodiments, the method and system are capable of producing a pH difference of more than 0.5 pH units between the anode electrolyte solution and a cathode electrolyte solution when the two electrolyte solutions are separated, e.g., by one or more ion exchange membranes, and when a voltage of 3V or less, 2.9 V or less or 2.5 V or less, or 2V or less is applied across the anode and cathode. In some
30 embodiments the method and system are capable of producing a pH difference of more than 1.0 pH units, or 2 pH units, or 4 pH units, or 6 pH units, or 8 pH units, or 10 pH units, or 12 pH units, or 14 pH units between a first electrolyte solution and a second electrolyte solution where the first electrolyte solution contacts an anode and the second electrolyte solution contacts a cathode, and the two electrolyte solutions are separated, e.g.,
35 by one or more ion exchange membranes, when a voltage of 0.1V or less is applied across the anode and cathode.

[0098] In another exemplary result and with reference to Fig. 4, a system as illustrated in Fig. 1 was configured and operated with constant current density while carbon dioxide gas was continuously dissolved

into the cathode compartment. In the system, the pH in the cathode electrolyte and the voltage across the anode and cathode were monitored. In the system, a platinum loaded gas diffusion electrode was utilized as the anode and a nickel mesh was utilized as the cathode. Original cell concentrations were 5 M NaCl, 1 M NaOH and 1 M HCl in the third electrolyte 122, the cathode electrolyte 108 and anode electrolyte 115, respectively. The ionic membranes utilized were obtained from Membrane International, Inc., of NJ, USA, in particular membrane no. AMI 7001 for anion exchange membrane 124, and membrane no. CMI 7000 for cation exchange membrane 120. As can be seen in Fig. 4, as the reaction proceeded, the pH of the cathode electrolyte decreased as carbon dioxide gas was absorbed in the cathode electrolyte. At the same time, the voltage across the anode and cathode also decreased.

10 **[0099]** As can be appreciated, the solubility of carbon dioxide in the cathode electrolyte is dependent on the pH of the electrolyte, and the voltage across the cathode and anode is dependent on the pH difference between the anode electrolyte and cathode electrolyte. Thus, as is illustrated in Fig. 4, the system can therefore be configured and operated at a specified pH and voltage to absorb carbon dioxide and produce carbonic acid, carbonate ions and/or bicarbonate ions in the cathode electrolyte. Hence, for example, as is 15 illustrated in Fig. 4, the system can be configured and operated at less than 1V across the anode, e.g., at 0.9V to produce a base solution with a pH of 10. In other embodiments, the system can be configured and operated at 0.85V to produce a base solution with a pH of 9. Other operating voltages include voltages in the range of 0.7V to 1.V as illustrated in Fig. 4. Similarly, other operating pH values include pH values in the range of 6 to 12. As discussed above, the base solution produced in the cathode electrolyte and comprising 20 carbonate and bicarbonate ions can be utilized with a divalent cation solution to sequester carbon dioxide by precipitating divalent cation carbonate and bicarbonates from the solution.

[00100] In some embodiments, divalent cations, e.g., magnesium ions or calcium ions are removed from the cathode electrolyte solution during parts of the process where the cathode and anode electrolytes are in contact with the ion exchange membranes. This is done to prevent scaling of the membranes, if necessary 25 for that particular membrane. Thus, in various embodiments the total concentration of divalent cations in the electrolyte solutions when they are in contact with the ion exchange membrane or membranes for any appreciable time is less than 0.06 mol/kg solution, or less than 0.06 mol/kg solution, or less than 0.04 mol/kg solution, or less than 0.02 mol/kg solution, or less than 0.01 mol/kg solution, or less than 0.005 mol/kg solution, or less than 0.001 mol/kg solution, or less than 0.0005 mol/kg solution, or less than 0.0001 mol/kg 30 solution, or less than 0.00005 mol/kg solution.

[00101] In embodiments where carbon dioxide gas is dissolved in the cathode electrolyte, as protons are removed from the cathode electrolyte more carbon dioxide may be dissolved to form carbonic acid, bicarbonate ions and/or carbonate ions. Depending on the pH of the cathode electrolyte the balance is shifted toward bicarbonate ions or toward carbonate ions, as is well understood in the art and as is illustrated in the carbonate speciation diagram, above. In these embodiments the pH of the cathode electrolyte solution may 35 decrease, remain the same, or increase, depending on the rate of removal of protons compared to rate of introduction of carbon dioxide. It will be appreciated that no carbonic acid, hydroxide ions, carbonate ions or

bicarbonate ions are formed in these embodiments, or that carbonic acid, hydroxide ions, carbonate ions, bicarbonate ions may not form during one period but form during another period.

[00102] In another embodiment, the present system and method are integrated with a carbonate and/or bicarbonate precipitation system (not illustrated) wherein a solution of divalent cations, when added to the present cathode electrolyte, causes formation of precipitates of divalent carbonate and/or bicarbonate compounds, e.g., calcium carbonate or magnesium carbonate and/or their bicarbonates. In various embodiments, the precipitated divalent carbonate and/or bicarbonate compounds may be utilized as building materials, e.g., cements and aggregates as described for example in commonly assigned U.S. Patent Application no. 12/126,776 filed on May 23, 2008, (available on the USPTO Public Pair website).

[00103] In an alternative embodiment, the present system and method are integrated with a mineral and/or material dissolution and recovery system (not illustrated) wherein the acidic anode electrolyte solution 115 or the basic cathode electrolyte 102 is utilized to dissolve calcium and/or magnesium-rich minerals e.g., serpentine or olivine, or waste materials, e.g., fly ash, red mud and the like, to form divalent cation solutions that may be utilized, e.g., to precipitate carbonates and/or bicarbonates as described herein. In various embodiments, the precipitated divalent carbonate and/or bicarbonate compounds may be utilized as building materials, e.g., cements and aggregates as described for example in commonly assigned U.S. Patent Application no. 12/126,776 filed on May 23, 2008, (available on the USPTO Public Pair website).

[00104] In an alternative embodiment, the present system and method are integrated with an industrial waste gas treatment system (not illustrated) for sequestering carbon dioxide and other constituents of industrial waste gases, e.g., sulfur gases, nitrogen oxide gases, metal and particulates, wherein by contacting the flue gas with a solution comprising divalent cations and the present cathode electrolyte comprising hydroxide, bicarbonate and/or carbonate ions, divalent cation carbonates and/or bicarbonates are precipitated as described in commonly assigned U.S. Patent Application no. 12/344,019 filed on December 24, 2008, (available on the USPTO Public Pair website). The precipitates, comprising, e.g., calcium and/or magnesium carbonates and bicarbonates in various embodiments may be utilized as building materials, e.g., as cements and aggregates, as described in commonly assigned U.S. Patent Application no. 12/126,776 filed on May 23, 2008, (available on the USPTO Public Pair website).

[00105] In another embodiment, the present system and method are integrated with an aqueous desalination system (not illustrated) wherein the partially desalinated water of the third electrolyte of the present system is used as feed-water for the desalination system, as described in commonly assigned U.S. Patent Application no. 12/163,205 filed on June 27, 2008, (available on the USPTO Public Pair website).

[00106] In an alternative embodiment, the present system and method are integrated with a carbonate and/or bicarbonate solution disposal system (not illustrated) wherein, rather than producing precipitates by contacting a solution of divalent cations with the first electrolyte solution to form precipitates, the system produces a slurry or suspension comprising carbonates and/or bicarbonates. In various embodiments, the slurry or suspension is disposed of in a location where it is held stable for an extended periods of time, e.g., the slurry/suspension is disposed in an ocean at a depth where the temperature and pressure are sufficient to

keep the slurry stable indefinitely, as described in U.S. Patent Application no. 12/344,019 filed on December 24, 2008, (available on the USPTO Public Pair website).

[00107] It will be understood that the scope of the claims should not be limited by the preferred embodiments set forth in the examples, but should be given the broadest interpretation consistent with the description as a whole.

5

CLAIMS

The invention claimed is:

- 5 1. An electrochemical system comprising:
- (a) a cathode compartment comprising a cathode electrolyte in contact with a cathode, wherein the cathode produces hydrogen gas, and wherein the cathode compartment is operatively configured to receive carbon dioxide from an industrial waste gas system which is part of a fossil fuel combusting plant or a cement plant; a gas/liquid contactor operatively connected to the industrial waste gas system wherein the gas/liquid
- 10 contactor contacts the cathode compartment with carbon dioxide from the industrial waste gas system; or combination thereof;
- (b) an anode compartment comprising an anode electrolyte in contact with an anode;
- (c) the cathode electrolyte comprising bicarbonate ions wherein the anode electrolyte and the cathode electrolyte have a pH differential of between 6-12;
- 15 (d) a hydrogen gas delivery system configured to direct hydrogen gas from the cathode to the anode; and a Nernst cell voltage of less than 0.8V across the anode and the cathode.
2. The system of claim 1, wherein the system is configured to absorb the carbon dioxide gas into the cathode electrolyte, and further wherein the cathode electrolyte comprises hydroxide ions, carbonic acid,
- 20 carbonate ions, or any combination thereof.
3. The system of claim 1, wherein the cathode compartment is partitioned into a first cathode electrolyte compartment and a second cathode electrolyte compartment by a partition such that on placing the cathode electrolyte in the cathode compartment, there is a liquid flow between the cathode electrolyte in the first
- 25 cathode electrolyte compartment and the cathode electrolyte in the second cathode electrolyte compartment and wherein the carbon dioxide gas is isolated from the cathode electrolyte in the second cathode electrolyte compartment such that the carbon dioxide gas is prevented from contacting the cathode.
4. The system of claim 1, wherein the system is configured to produce hydroxide ions in the cathode
- 30 electrolyte with less than 0.6V across the anode and cathode.
5. The system of claim 3, wherein the system is configured to migrate hydroxide ions from the second cathode electrolyte compartment to the first cathode electrolyte compartment.
- 35 6. The system of claim 1, wherein the cathode compartment is operatively connected to a hydroxide, carbonate and/or bicarbonate precipitation system, wherein the precipitation system is configured to utilize the cathode electrolyte to produce hydroxide, divalent cation carbonates and/or divalent cation bicarbonate compounds.

7. The system of claim 1, further comprising at least one ion exchange membrane between the anode compartment and the cathode compartment.
8. The system of claim 7, wherein the at least one ion exchange membrane comprises a cation exchange membrane separating the cathode electrolyte from a third electrolyte, an anion exchange membrane separating the anode electrolyte from the third electrolyte, or both the cation exchange membrane separating the cathode electrolyte from a third electrolyte and the anion exchange membrane separating the anode electrolyte from the third electrolyte.
9. The system of claim 8, wherein the third electrolyte comprises sodium ions and chloride ions and wherein the system is configured to migrate the sodium ions from the third electrolyte to the cathode electrolyte through the cation exchange membrane, and migrate the chloride ions from the third electrolyte to the anode electrolyte through the anion exchange membrane, and further wherein the system is configured to produce hydrochloric acid in the anode electrolyte.
10. The system of claim 9, wherein the system is configured to produce sodium hydroxide, sodium carbonate and/or sodium bicarbonate in the cathode electrolyte and partially desalinated water in the third electrolyte.
11. The system of claim 1, wherein the gas/liquid contactor is configured to contact the carbon dioxide from the industrial waste gas system with cathode electrolyte withdrawn from the cathode compartment.
12. The system of claim 11, wherein the gas/liquid contactor is configured to return the cathode electrolyte comprising carbon dioxide to the cathode compartment.
13. An electrochemical method comprising: contacting an anode electrolyte with an anode in an anode compartment wherein the anode oxidizes hydrogen gas to hydrogen ions; contacting a cathode electrolyte with a cathode in a cathode compartment wherein the cathode produces hydroxide ions and hydrogen gas; directing hydrogen gas produced at the cathode to the anode; directing an industrial waste gas comprising carbon dioxide into the cathode electrolyte in the cathode compartment or directing carbon dioxide into the cathode electrolyte from a gas/liquid contactor that is in contact with an industrial waste gas; converting bicarbonate ions to carbonate ions in the cathode electrolyte and producing a pH differential between the anode electrolyte and the cathode electrolyte of between 6-12; and applying a Nernst cell voltage of less than 0.8V across the cathode and the anode.
14. The method of claim 13, comprising producing hydroxide ions, carbonic acid, carbonate ions, and/or bicarbonate ions in the cathode electrolyte.

15. The method of claim 13, wherein the voltage applied across the anode and the cathode is less than 0.6V.
16. The method of claim 14, further comprising producing hydrogen ions at the anode.
- 5 17. The method of claim 13, further comprising separating the cathode electrolyte from a third electrolyte by a cation exchange membrane, separating the anode electrolyte from the third electrolyte by an anion exchange membrane, or both.
- 10 18. The method of claim 17, wherein the third electrolyte comprises sodium ions and chloride ions.
19. The method of claim 18, comprising separating the cathode electrolyte from the third electrolyte by the cation exchange membrane and separating the anode electrolyte from the third electrolyte by the anion exchange membrane and wherein the third electrolyte is positioned between the cathode electrolyte and the anode electrolyte and further comprising migrating the sodium ions from the third electrolyte to the cathode electrolyte across the cation exchange membrane, and migrating the chloride ions from the third electrolyte to the anode electrolyte across the anion exchange membrane, producing an acid in the anode electrolyte, and producing sodium carbonate, sodium bicarbonate or sodium hydroxide in the cathode electrolyte.
- 15 20. The method of claim 19, further comprising contacting the cathode electrolyte with a divalent cation solution to produce divalent cation hydroxide, carbonate and/or bicarbonate compounds, wherein the divalent carbonate and/or bicarbonate compounds comprise calcium, magnesium, or both calcium and magnesium.
- 20

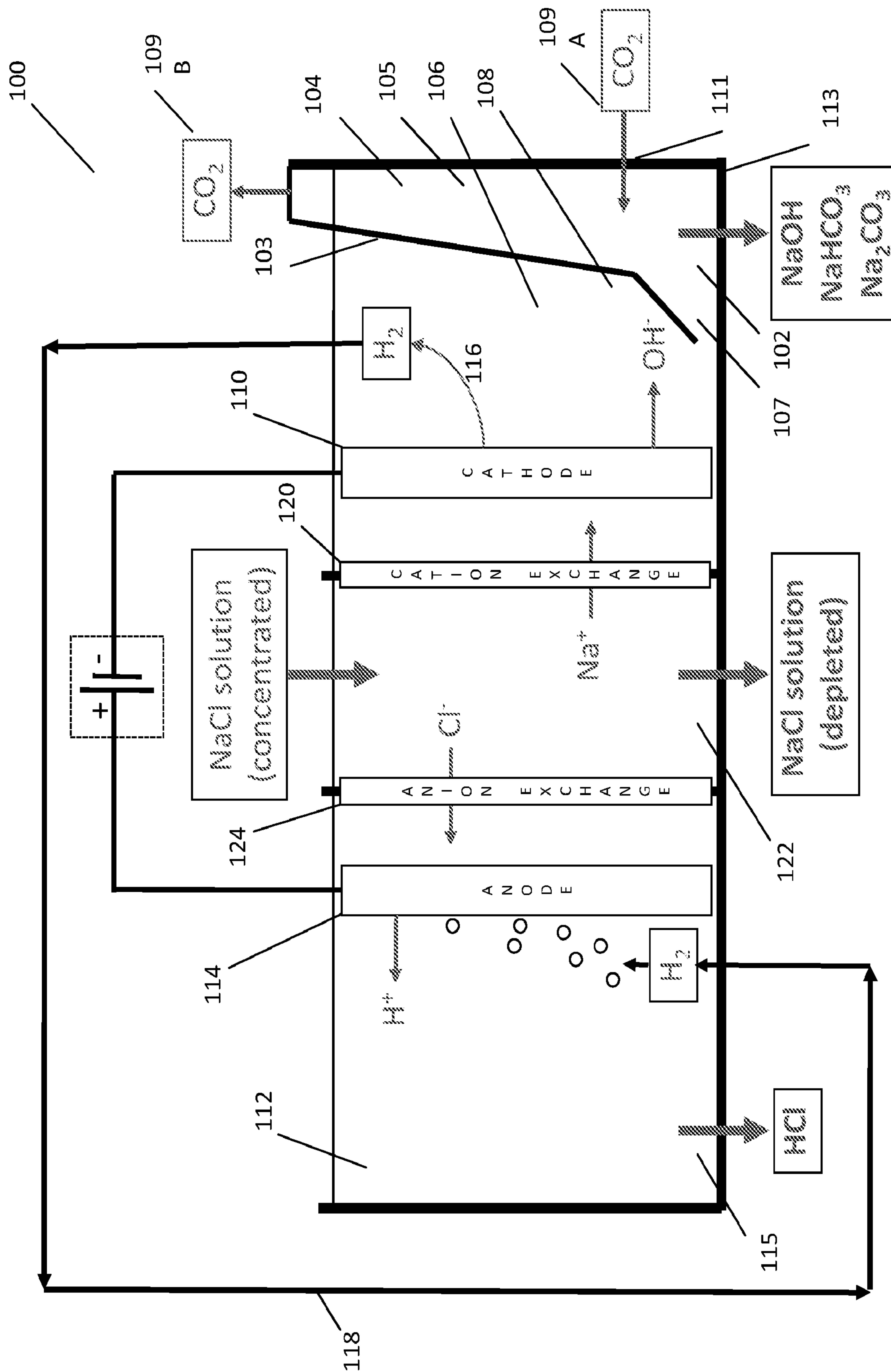

Fig. 1

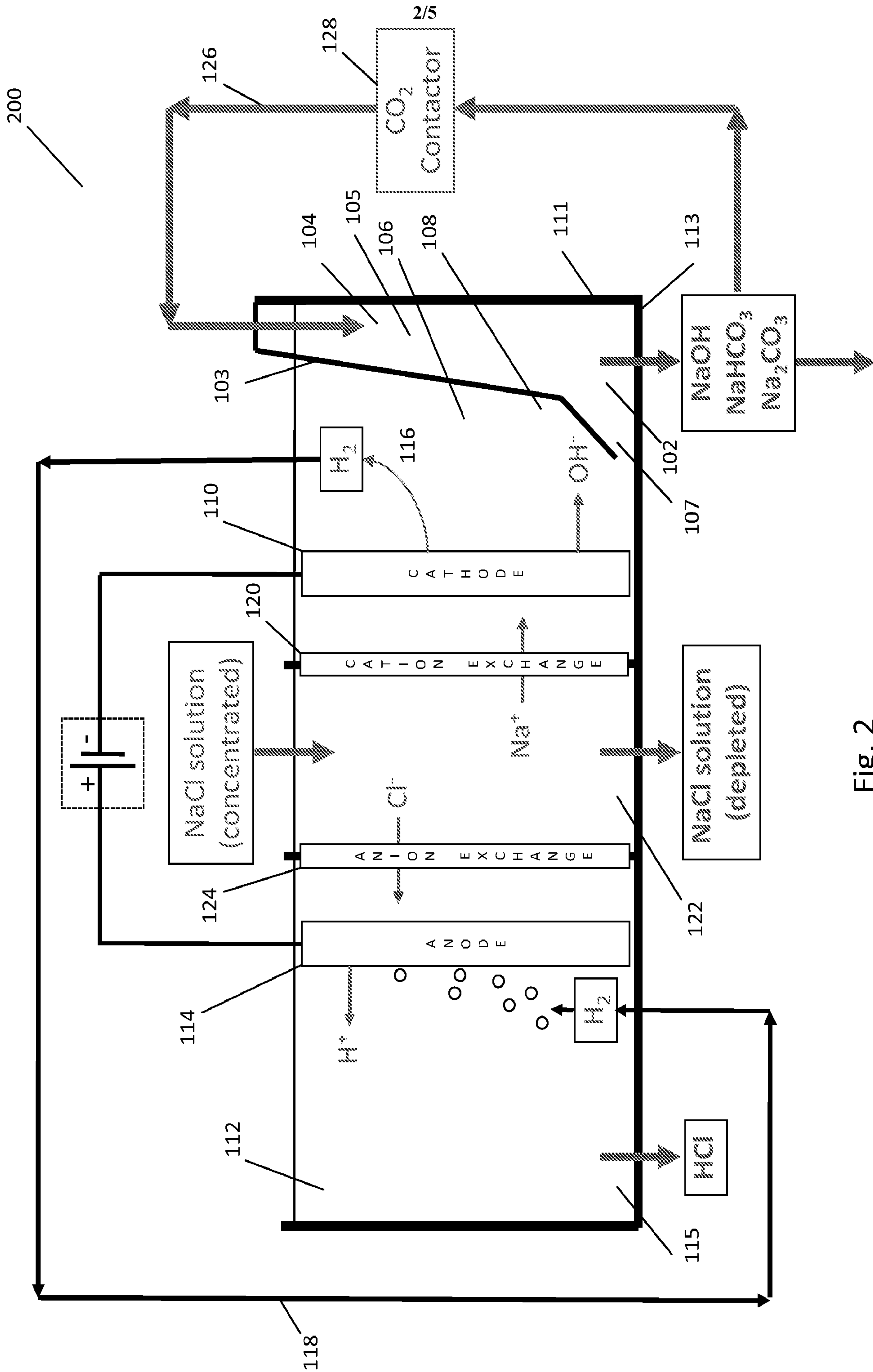

Fig. 2

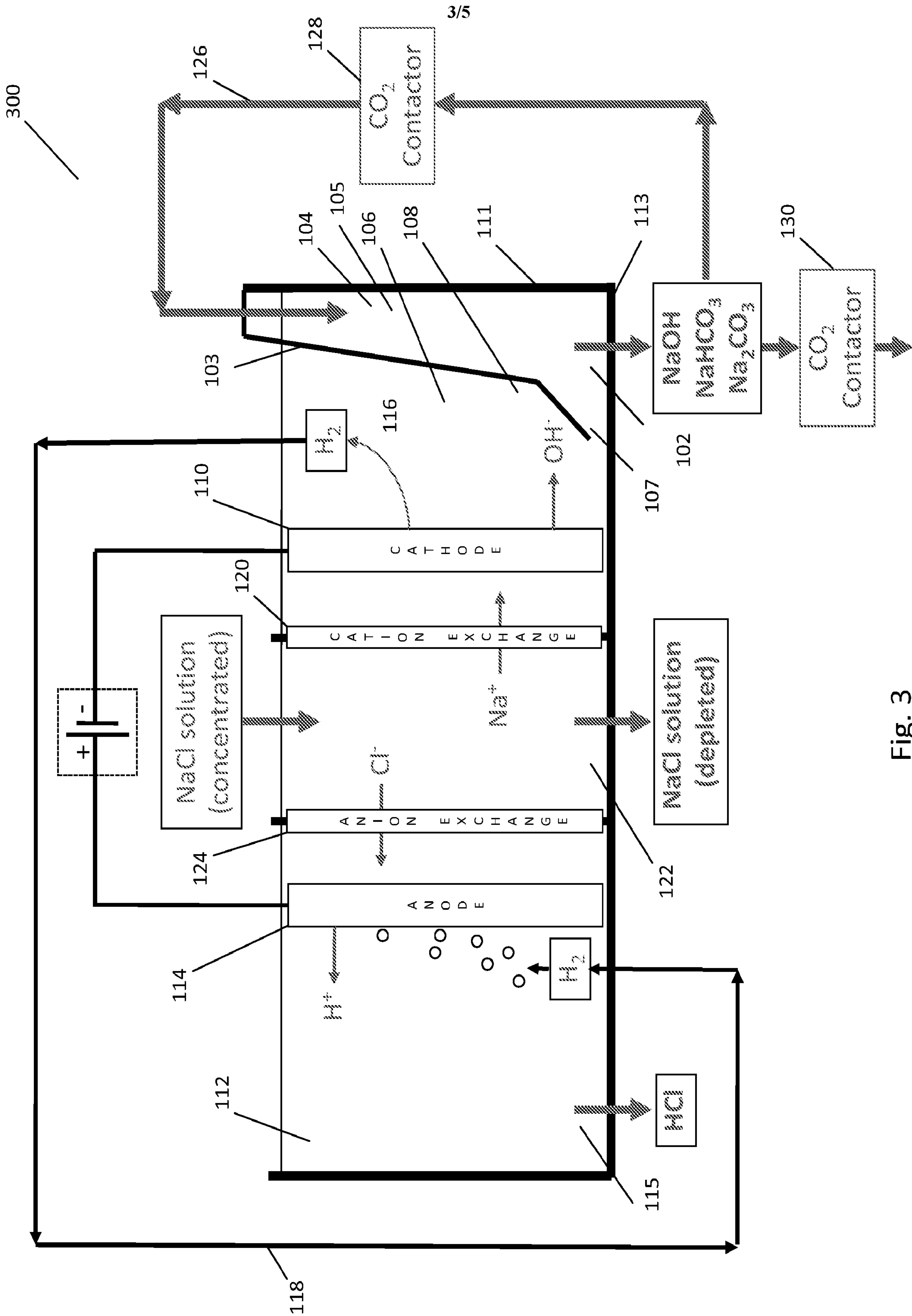

Fig. 3

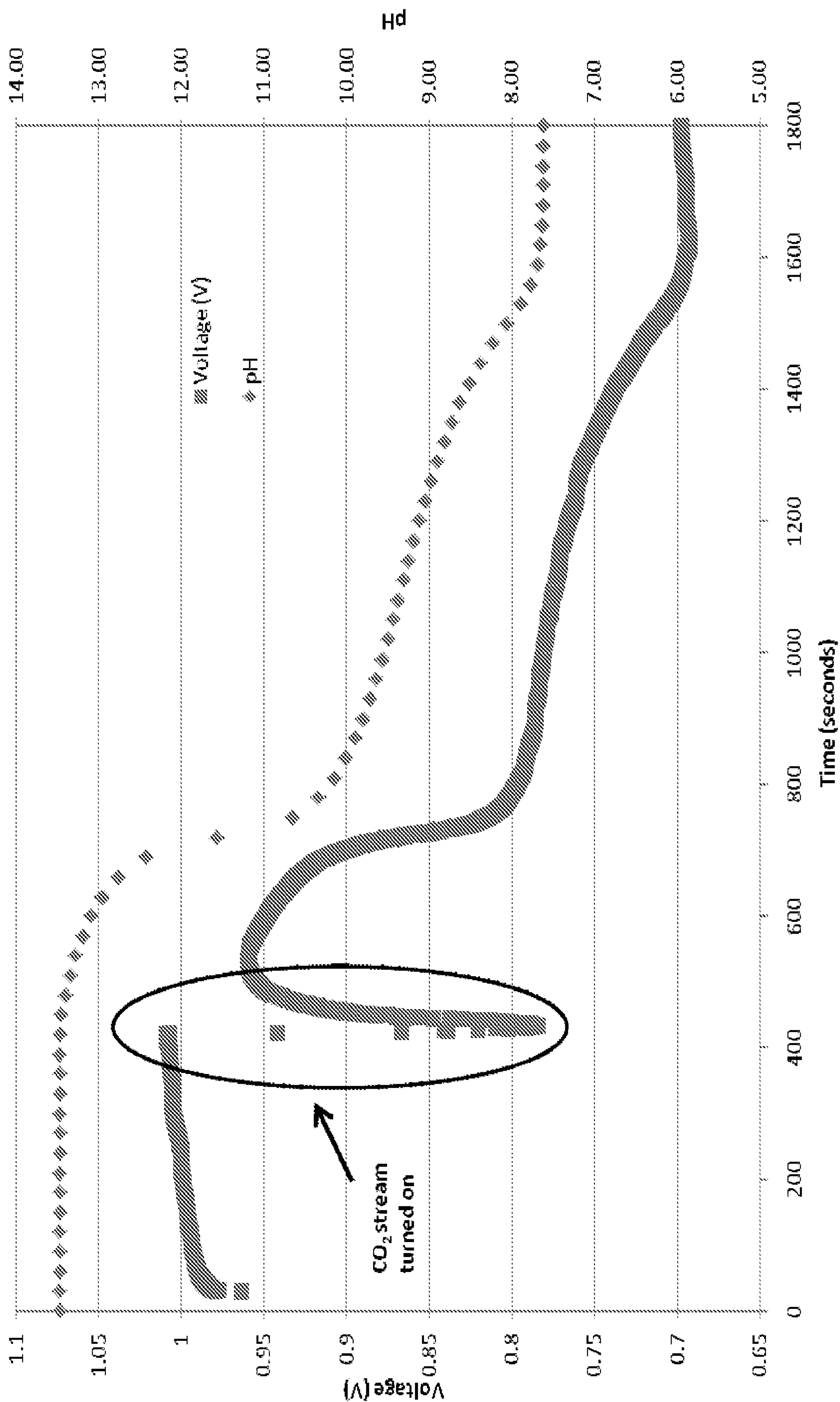

Fig. 4

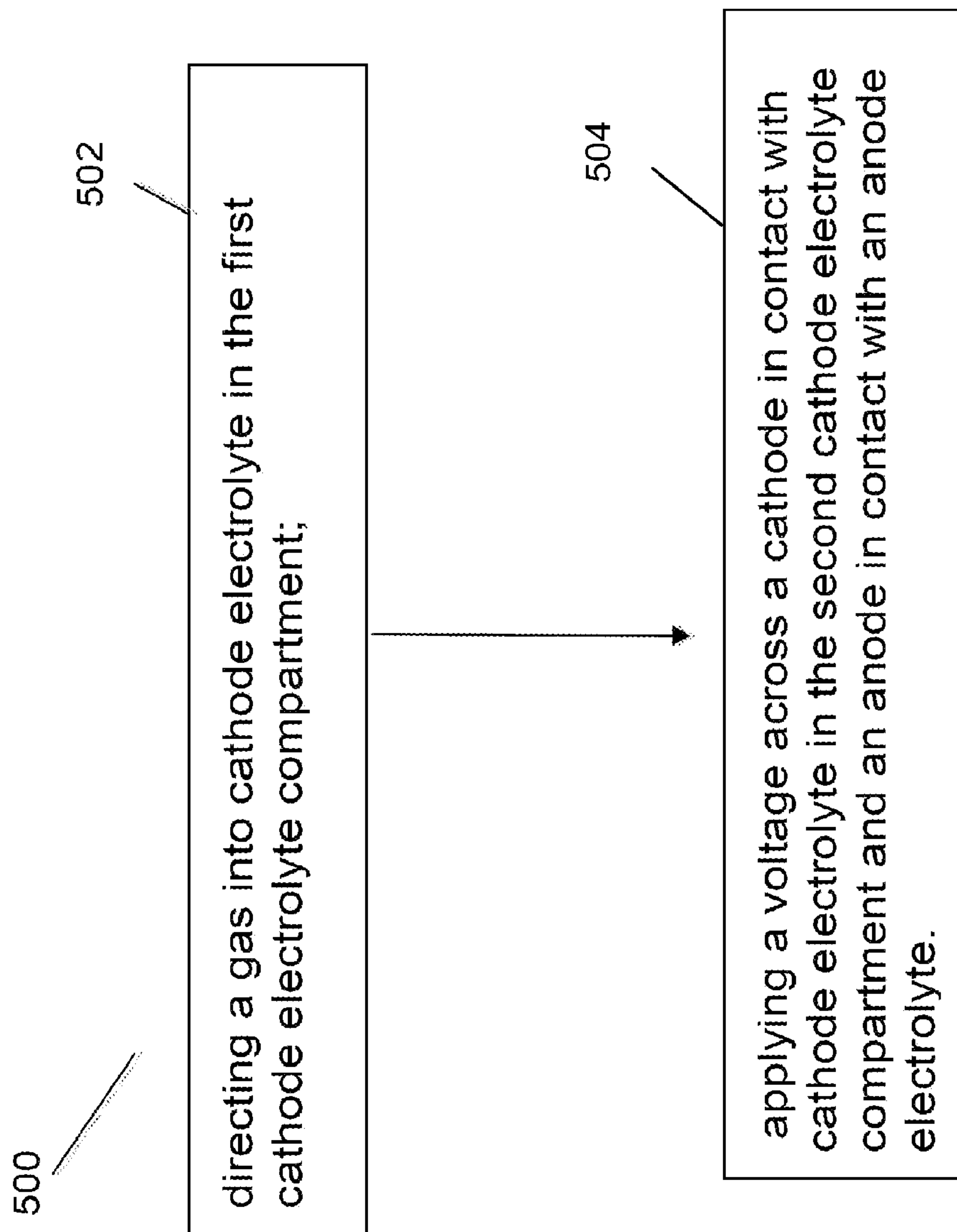

Fig. 5

Carbonate/Bicarbonate speciation in H₂O v. pH at 25 °C.

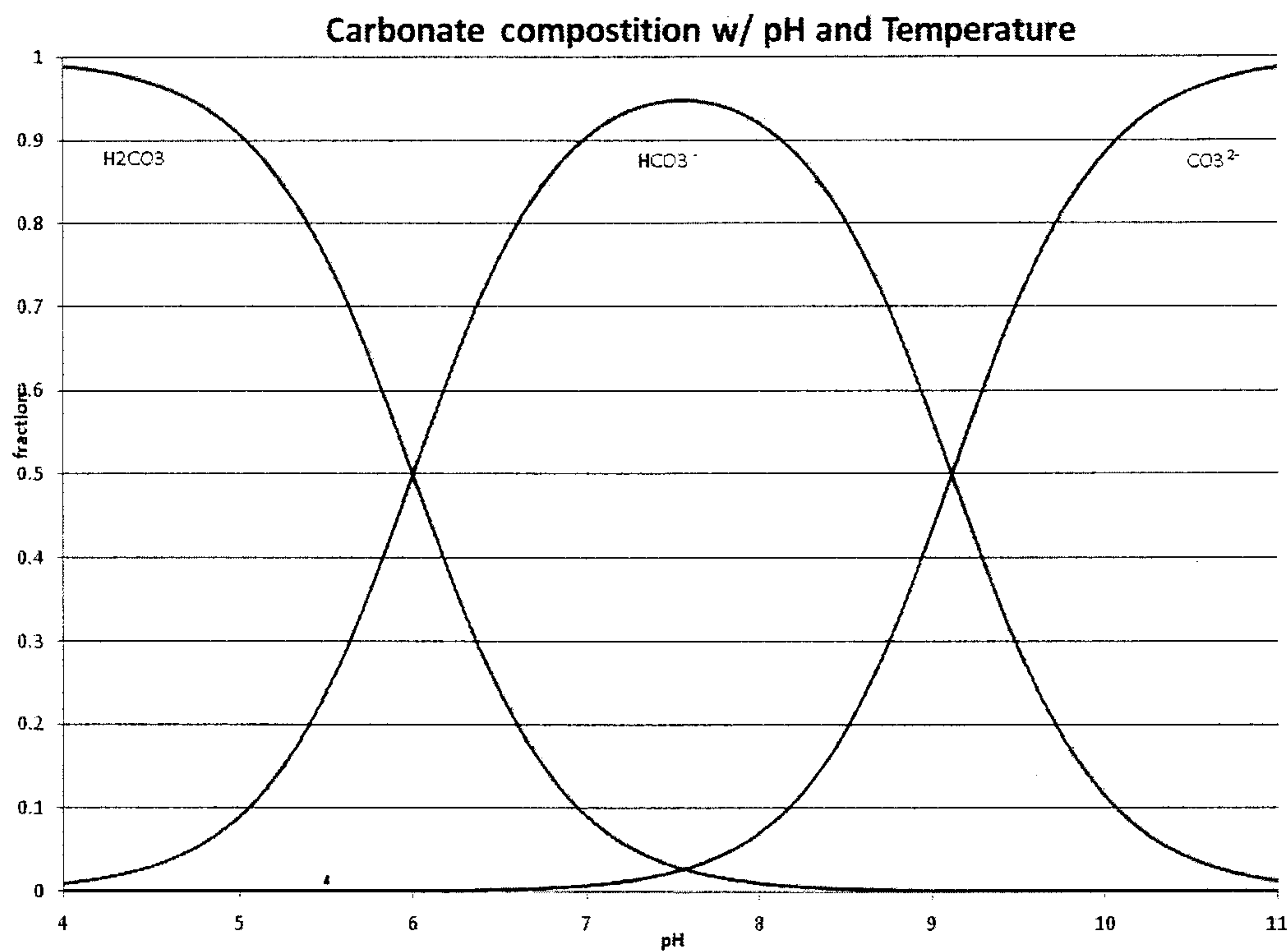

Fig. 6

Scenario 1: Bicarbonate Ion Generation in the Cathode Electrolyte

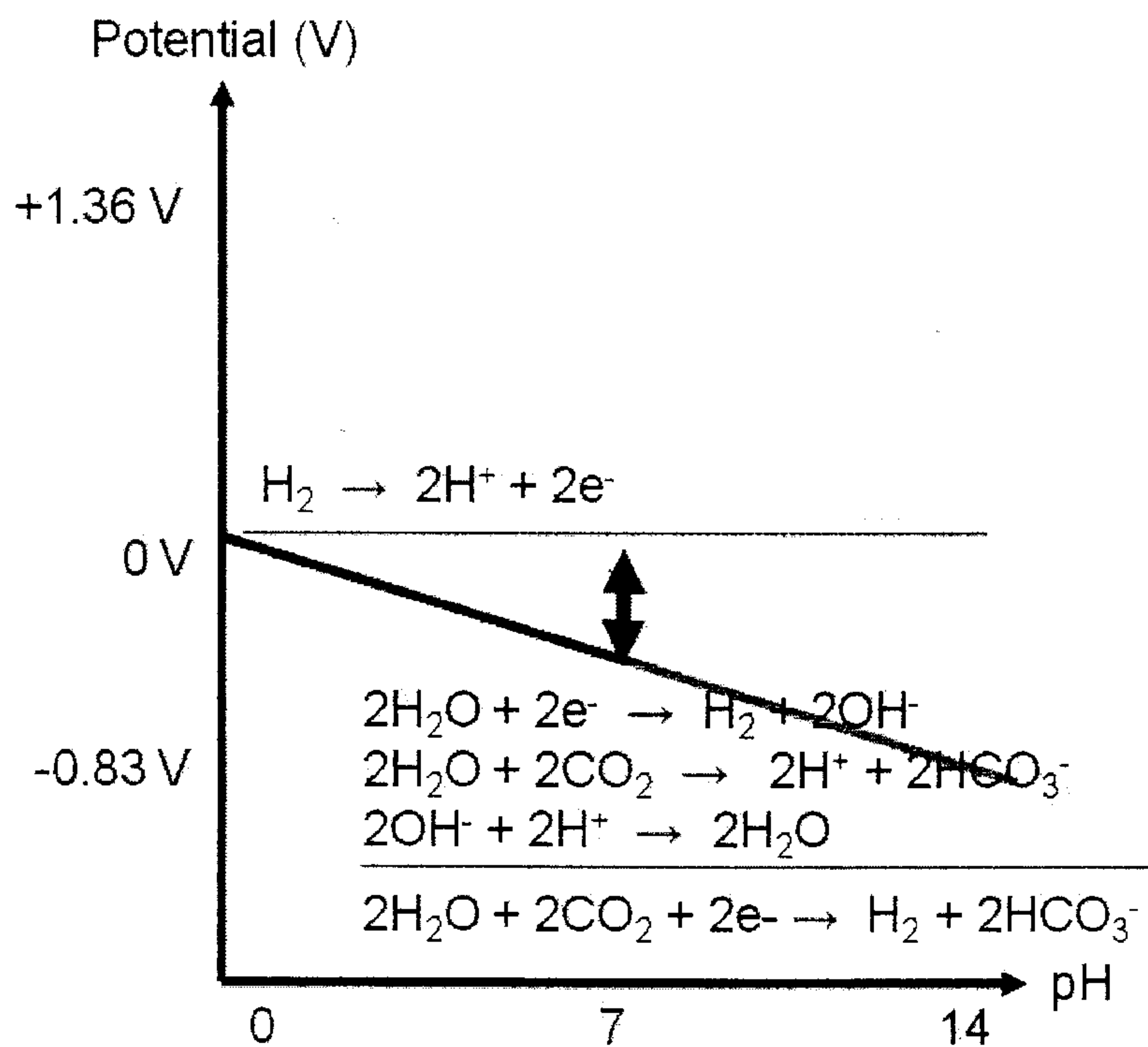

Fig. 7

