



⑫ **EUROPEAN PATENT APPLICATION**

⑰ Application number: **90309364.9**

⑸ Int. Cl.<sup>5</sup>: **G08B 3/10**

⑱ Date of filing: **28.08.90**

⑳ Priority: **06.09.89 GB 8920104**  
**23.08.90 GB 9018501**

㉓ Date of publication of application:  
**13.03.91 Bulletin 91/11**

㉔ Designated Contracting States:  
**AT BE CH DE DK ES FR GB GR IT LI LU NL SE**

㉑ Applicant: **Gauthier, Michel J.**  
**16 Dysart Avenue**  
**Kingston-on-Thames, Surrey KT2 5RB(GB)**

Applicant: **Taylor, Michael R.**  
**Southways, 23 Butts Road**  
**Chiseldon, Swindon, Wiltshire(GB)**

㉒ Inventor: **Gauthier, Michel J.**  
**16 Dysart Avenue**  
**Kingston-on-Thames, Surrey KT2 5RB(GB)**  
Inventor: **Taylor, Michael R.**  
**Southways, 23 Butts Road**  
**Chiseldon, Swindon, Wiltshire(GB)**

㉕ Representative: **Lawrence, Brian Richard**  
**59 Shenfield Place**  
**Shenfield Brentwood Essex CM15 9AH(GB)**

⑤④ **Access control devices and systems incorporating such devices.**

⑤⑦ An access control device in the form of a programmable electronic 'key' 33 is provided, especially for use in hotels, for allowing access to restricted access areas, e.g. hotel rooms protected by programmable door locks. The electronic 'key' 33 is provided with a paging device for receiving paging signals whereby messages 25 may be transmitted to the holder of the 'key' 33.

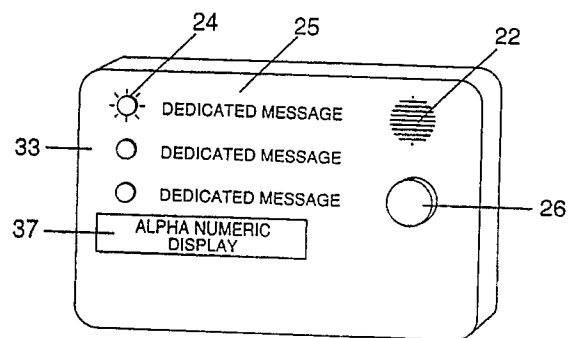

FIGURE 3

## ACCESS CONTROL DEVICES AND SYSTEMS INCORPORATING SUCH DEVICES

### TECHNICAL FIELD

This invention relates to access control devices and to systems incorporating such devices. It is particularly applicable to such devices and systems for use within hotel environments, commercial and financial offices and industrial complexes.

### BACKGROUND ART

#### Access Control.

Security is an increasing problem in every walk of life and is particularly acute within the hotel industry. Theft can be in the form of property stolen from hotel bedrooms or it can be in the form of unauthorised and unpaid usage of hotel facilities such as gymnasiums, saunas, swimming pools. Theft can even take the form of unauthorised consumption of food and drink by non-registered guests. Increased security in the form of access control can therefore readily provide benefits for both guest and hotel operator alike. The guests gain from added security, whilst the operator gains from reduced levels of fraud.

In order to contain the above problems, increasing effort is being focused on the design of secure access control systems.

Electro-mechanical programmable door locks represent important elements of access control systems and are being installed in increasing numbers, particularly in high technology hotels which cater for the international business traveller. Whenever a new guest registers in one of these hotels he may be allocated a unique 'key' which is coded and can only be used to operate the lock controlling access to his room - and then only during the period of his stay. The 'key' may be constructed from a thin strip of card or plastic or from a laminated hybrid structure.

Lock code changes are routinely carried out by a member of the hotel staff physically reprogramming the lock mechanisms - usually during or after room preparation. This process is often achieved by the insertion of a two part coded card into the door lock mechanism - one part of the card, containing the new code, being snapped off and left within the lock mechanism, whilst the other part, the 'key', is removed and deposited with hotel check-in staff. The 'key' is then issued to the guest who is allocated the room with the matching coded lock.

If the 'key' is lost during the guest's stay then

the door lock is reprogrammed with another two part coded card and the 'key' portion is once more issued to the guest. When the guest checks out of the hotel the door lock allowing access to the room in which the guest stayed is once again reprogrammed. The old 'key' is either discarded or retained by the guest as a souvenir.

Lock codes are normally written on a magnetic strip printed or attached by some means onto the surface of the 'key', although it will be appreciated that the same code may be electronically or optically stored within the body of the 'key' or even stored in the form of physical holes or deformations on part of the 'key'.

Many hotel guests entertain business clients or attend conferences and presentations within hotels whilst simultaneously needing to be kept informed of other business activities via incoming telephone calls and messages. Telephone messages are frequently left with hotel telephone operators when the intended recipient cannot be found; an illuminated light on the guest's telephone being the only indication of a lost telephone call or of a message left with the hotel telephone operator. Such failures to establish direct telephone contact during business negotiations can prove very costly, particularly in situations where accurate information and precise timing are crucial.

It is an object of the present invention to provide an improved access control device and access control system which incorporates means for communicating with hotel guests whilst they are in the vicinity of the hotel. It will be appreciated that whilst the invention is particularly applicable to the hotel industry, it will have much wider application.

### DISCLOSURE OF THE INVENTION

According to one aspect of the present invention there is provided an access control device which is programmable to allow access to a restricted access area, characterised by pager means which is formed as part of said device for receiving a transmitted paging signal.

Thus, by incorporating a pager within the usual access control device or electronic 'key', in a hotel application, for example, all guests who have been issued with an electronic key may be paged should contact need to be made with them.

In a preferred arrangement, said device will take the form of an electronic 'smart' card, which conveniently comprises means for affording an audible or visual indication when a paging signal has been received.

Advantageously, a received paging signal may be represented by illuminating a light adjacent or near to text which is descriptive of the intended message of the received paging signal, or an alpha-numeric display may be provided for displaying a received paging signal.

It may be arranged that the access control device is programmed with an electronic, magnetic, optical, mechanical or electrical code to allow access to a restricted access area.

In an especially preferred arrangement according to the first aspect of the present invention, the access control device will include a transponding arrangement for receiving an interrogation signal and for transponding a predetermined code when an interrogation signal has been received to allow access to a restricted access area.

Advantageously said access control device may be programmed with a paging code which determines the paging signals which are receivable by said device, and said device may be adapted to be used as an electronic data transfer device e.g. for electronic credit, charge card or data bank purposes.

According to a second aspect of the present invention there is provided an access control system comprising a plurality of access control devices according to the aforesaid first aspect of the present invention and further comprising coding means for programming each of said access control devices with an access code to allow access to a specified restricted access area, further coding means for programming each specified restricted access area with an access code which corresponds to the access code of one or more of said access control devices, and means for transmitting a coded paging signal to one or more of said access control devices.

In a preferred arrangement for carrying out the invention according to the second aspect, a programmable security device will be provided for restricting access to each specified restricted access area, said further coding means being effective for programming each programmable security device with an access code, each of said programmable security devices being responsive to one or more access control devices having the same code for allowing access to the specified restricted area thereof.

In an especially preferred arrangement according to the second aspect of the invention in which said access control devices each include a transponding arrangement, it will be arranged that each programmable security device comprises means for transmitting an interrogating signal when it is actuated, and means for receiving a transponded signal from an access control device which is in receipt of said interrogating signal, said program-

mable security device being responsive to a transponded signal from an access control device having the same access with which it is programmed for allowing access to the restricted access area thereof.

It may be arranged that said programmable security devices are programmed manually or are programmed remotely, in which case a signal may be transmitted to said programmable security devices for programming each said programmable security device with its access code.

In an access control system for use in a hotel reservation system, it may be arranged that said access control devices constitute room key devices which are programmed with an access code which is also programmed into an electronic door lock associated with a specified room of said hotel to allow access to said room when the access code of said access control device corresponds to the access code of said electronic door lock, means being provided for transmitting a coded paging signal to one or more of said access control devices.

#### BRIEF DESCRIPTION OF THE DRAWINGS

An exemplary embodiment of the invention will now be described reference being made to the accompanying drawings, in which:

Figure 1 is a block schematic diagram of an access control system in accordance with the present invention;

Figure 2 is a perspective view of one form of access control device in accordance with the present invention, for use in the system of Figure 1;

Figure 3 is a perspective view of another form of access control device in accordance with the present invention, for use in the system of Figure 1;

Figure 4 is a block schematic diagram of the access control device of Figure 3;

Figure 5 is a diagrammatic perspective view of a programmable door lock mechanism for use in the system of Figure 1;

Figure 6 is a block schematic diagram of the programmable door lock mechanism of Figure 5;

Figure 7 is an illustration of typical code fields which can be used to create the combination codes for use in the system of Figure 1 and the access control devices of Figures 2 and 3;

Figure 8 is a flow chart illustrating the procedure for programming the access control devices of Figures 2 and 3 and the programmable door lock mechanism of Figures 5 and 6;

Figure 9 is a flow chart illustrating the operation

of the programmable door lock mechanism of Figures 5 and 6;

Figure 10 is a flow chart illustrating the operation of the paging base station of the access control system of Figure 1; and

Figure 11 is a flow chart illustrating the operation of the access control device of Figures 3 and 4.

#### DETAILED DESCRIPTION OF THE INVENTION

The exemplary embodiment of the invention to be described is based on use in a hotel installation but it should be appreciated that the invention has much wider application and may be used, for example, within commercial, industrial, business, sports and leisure environments.

The invention is based on the use of an access control device in the form of an electronic 'key' which incorporates a 'pager' which may be used to make contact with the person who has possession of the 'key'. For the purposes of the following description the electronic 'key' incorporating the pager will be referred to as a 'PAGEKEY'.

The access control system which is to be described is based on the use of a programmable door lock mechanism which is fitted to each of the hotel rooms, each of the door lock mechanisms being programmed with a unique code such that it can only be opened, to gain access to the room, by a 'PAGEKEY' which is coded with the same unique code. Each 'PAGEKEY' is provided with a paging facility for receiving a transmitted paging signal which is used to contact the person in possession of the 'PAGEKEY'.

In Figure 1 of the drawings there is shown a hotel access control system which comprises a control unit 18, which is typically located on or near the hotel reception desk. Each of the rooms of the hotel is fitted with a programmable door lock mechanism 13 and a room telephone 17, and each guest of the hotel is provided with a 'PAGEKEY' 14.

The control unit 18 comprises a reception check-in console 11 which is interconnected with the hotel telephone exchange 16, a 'PAGEKEY' and lock programmer 12, and a 'PAGEKEY' paging base station 15.

When a new guest checks into the hotel, the receptionist identifies a suitable room for the guest via the check-in console 11 which also generates a suitable code which is to be allocated to that particular room for the period that the room is to be allocated to the new guest. The code generated by check-in console 11 is fed to the 'PAGEKEY' and lock programmer 12 into which is inserted the 'PAGEKEY' 14 which is to be allocated to the new

guest. The 'PAGEKEY' and lock programmer 12 codes the 'PAGEKEY' 14 with the required code and the code is also fed to the 'PAGEKEY' paging base station 15 where it is transmitted via aerial 19 to the programmable door lock mechanism 13, via its aerial 52, of the room which has been allocated to the new guest. The coded 'PAGEKEY' is then issued to the new guest which enables them to gain access only to the room which has been allocated to them. Other areas of the hotel which are provided only for the benefit of hotel guests, such as gymnasiums, saunas, swimming pools, etc. may also be provided with programmable door lock mechanisms 13, which are programmed such that any guest having a valid 'PAGEKEY' can gain access thereto.

If the hotel receptionist needs to contact a particular hotel guest for any reason, a coded paging signal is transmitted by the 'PAGEKEY' paging and base station 15, via its aerial 19, to the appropriately coded 'PAGEKEY' 14, via its aerial 20. In this way the hotel receptionist can make direct contact with any required hotel guest. It may also be arranged that when a telephone call is received for a hotel guest, when the call is transferred to the guest's room telephone, if the guest is absent and unable to answer the call, it may be arranged that a paging signal is transmitted to the 'PAGEKEY' of the hotel guest in question who will then know that contact should be made to the hotel reception.

The paging signal which is transmitted to the 'PAGEKEY' 14 by the 'PAGEKEY' paging base station 15 of Figure 1 may take a variety of different forms.

Radio page receivers are finding widespread use throughout the world and are currently classified into two types. Firstly, there is the type which only generates an attention getting tone or flashes a light emitting diode (LED) on reception and identification of an appropriate call code. For the purposes of this invention this receiver will be called a tone-only type of receiver. The second type of receiver can display a variety of messages in addition to the generation of an audible tone and will be called a receiver of the display type.

There are also different types of paging system which provide varying degrees of coverage. For example, some systems provide paging coverage over typically several hundred miles or more, whilst other systems hereafter referred to as local area paging systems, provide coverage restricted to defined areas such as industrial or commercial premises. Of particular relevance to this invention is the local area paging system which may use electromagnetic radiation, inductive pick-up, ultrasonic or infra-red radiation as a means of data communication between base station and receiver and in some cases between receiver and base station.

In Figure 2 of the drawings there is shown a 'PAGEKEY' 23 (corresponding to 'PAGEKEY' 14 of Figure 1) which incorporates a tone-only type of page receiver. The 'PAGEKEY' 23 is based on 'smart card' technology and is similar in construction to a thin pocket calculator and consists of an electronic structure incorporating typically semiconductor memories, processing and communication circuits, an antenna, etched or wound coils, tone transducers, displays, switches and subminiature batteries. The 'PAGEKEY' 23 includes a magnetic, optical, mechanical, or electronically readable strip or electrical connection 21 attached to it, and by means of which the unique code which is allocated to the 'PAGEKEY' 23 is stored therein or input thereto. When the 'PAGEKEY' 23 receives a paging signal it illuminates a light source 24, which may, for example, be indicative of a telephone call having been received as indicated by the 'TELEPHONE' message 25, and/or it may emit an audible tone from beeper 22. The light 24 and the audible tone may be terminated manually by operating a push button 26 or they may be terminated by the reception console unit 18 (Figure 1).

In Figure 3 of the drawings there is shown a 'PAGEKEY' 33 (corresponding to 'PAGEKEY' 14 of Figure 1), which is similar to the 'PAGEKEY' 23 of Figure 2 but which is of the display type and which, as will be described, incorporates a transponder for accessing its stored code. The 'PAGEKEY' 33 of Figure 3 includes three light sources 24 each associated with a particular dedicated message 25 printed on the surface of the 'PAGEKEY' 33, the light sources 24 being selectively lit in response to a received paging signal dependent upon the particular dedicated message being sent. The 'PAGEKEY' 33 is also provided with an alphanumeric display 37 by means of which messages stored within the 'PAGEKEY' 33 can be displayed.

In Figure 7 of the drawings, there is shown a typical code field for generating a combination code suitable for use with the access control system of Figure 1 and the 'PAGEKEY' of Figure 3. The code series of Figure 7 comprises a 'Guest' code X (typically of 16 bits) as indicated at 71, a 'Room' code Y (typically of 12 bits) as indicated at 72, and a 'Message' code Z (typically 4 bits) as indicated at 73. It will be appreciated that the combination of codes may be achieved using a variety of techniques, the salient feature being that part of the code is determined from the code allocated to the guest and part from the code allocated to either the room number or phone extension within the room. If the guest code X consisted of 16 binary bits for example, then 65,536 unique guest codes could be issued before all code possibilities were exhausted. If the room code

Y consisted of 12 binary bits, then 4,096 unique room codes could be allocated before all room code possibilities were exhausted.

It is an additional feature of this invention that by combining every possible 16 bit guest code X with every possible 12 bit room code Y, a total of 268,435,456 unique guest/room combination codes could be issued before all combination codes were exhausted. Such a quantity of numbers is considered to be sufficient to provide more than adequate security in any high-technology hotel or environment. The possibility of an intruder successfully hacking a counterfeit 'PAGEKEY' combination code is considered improbable, and in any case the 'hacking' process may readily be detected by the programmable door lock mechanism 13 (Figure 1).

It will be appreciated that although 16 and 12 bit codes have been used in the above example, larger or smaller codes may be used depending on the number of unique combination codes required.

The message code 73 may be used to transmit the particular message which 'PAGEKEY' 33 of Figure 3 is required to display. With a 4 bit code up to sixteen different messages may be selected, but it should be appreciated that the message code 73 may comprise more or less bits dependent upon the number of displayed messages required.

In Figure 4 of the drawings there is shown the block schematic diagram of the 'PAGEKEY' 33 of Figure 3. When the 'PAGEKEY' 33 of Figure 3 is used in the paging mode, a paging signal is received by antenna 20 and is fed, via transmit/receive (T/R) switch 46, to a receiver 41 in which it is detected and demodulated. The demodulated signal from receiver 41 is decoded by the central processor unit (CPU) 42 and compares the code of the paging signal with the code which was programmed into 'PAGEKEY' 33 and which is stored in memory 43. If the two codes correspond then the message code Z is decoded by the CPU 42 and, via input/output (I/O) driver 44, is used to selectively activate beeper 22, light sources 24 or display 37, the push button 26 being provided for 'reset' purposes.

As has already been mentioned, the 'PAGEKEY' 33 of Figure 4 is provided with a transponder for accessing its stored code and which obviates the need to actually insert the 'PAGEKEY' 33 in a programmable lock mechanism 13 (Figure 1) when entrance to a hotel room is required.

When the 'PAGEKEY' 33 of Figure 4 is used in its transponding mode, it receives and decodes an interrogation signal generated by the programmable lock mechanism 13 (as will be described). The combination code which has been programmed into the 'PAGEKEY' 33 and which is stored in memory 43 is then output to the antenna 20 by a short range transmitter 45 via I/O driver 44 and T/R

switch 46. The combination code transmitted by the transmitter 45 is received by the programmable lock mechanism which initiated the interrogation signal and is used to selectively open the lock as will be described with reference to Figure 5.

In Figure 5 of the drawings there is shown a diagrammatic view of a programmable door lock mechanism 13 which is attached to the door or door frame 61 of a hotel room. In Figure 6 of the drawings there is depicted a block schematic diagram of the programmable door lock mechanism of Figure 5. The mechanism 13 comprises a handle 62, the spindle of which is provided with a cam 58 which, when the handle 62 is turned, causes a microswitch 55 or other suitable switch to be operated. The output from the microswitch 55 is applied to an access control module 59 which will be described in greater detail with reference to Figure 6. The access control module 59 is powered from a battery 51 and is connected to an antenna 52 and to the solenoid 49 of a lock mechanism 50. The lock mechanism 50 is provided with a protruding door catch 60 which normally locks the hotel door closed but which is retracted when the solenoid 49 of the lock mechanism 50 is activated to release the door.

Turning now to Figure 6, the access control module 59 of Figure 5 comprises a transmit/receive (T/R) switch 54 to which the antenna 52 is connected, a receiver (Rx) 48, a central processor unit (CPU) 47, a memory 53, a short range transmitter (Tx) 57 and input/output (I/O) driver 56 to which the lock mechanism 50 and the microswitch 55 are connected.

The programmable door lock mechanism 13 of Figures 5 and 6 operates as follows. Remote programming of the door lock mechanism is achieved by transmitting the required code from the paging base station 15 of Figure 1. This code is received by the antenna 52 and applied via T/R switch 54 to receiver 48 in which it is received and demodulated. The transmitted code is decoded by CPU 47 and stored in memory 53.

When a 'PAGEKEY' 33 (Figure 3) is in the vicinity of the programmable door lock mechanism 13 and the handle 62 thereof is turned, the closing of the microswitch 55 is detected by the CPU 47 via I/O driver 56, and is used to generate an interrogation signal which is transmitted by transmitter 57 and antenna 52 via I/O driver 56 and T/R switch 54.

As has been described with reference to Figure 4, when the interrogation signal is received by the 'PAGEKEY' 33 it transponds by transmitting its own combination code and this is received by the receiver 48 of Figure 6 via the antenna 52 and T/R switch 54. The received combination code is decoded by CPU 47 and if it corresponds to its own

code stored in memory 53 it causes the solenoid 49 of the lock mechanism 50 to be activated to cause the door catch 60 (figure 5) to be retracted to release the door and allow access to the hotel room. If the received combination code does not correspond to the code stored in memory 53, this may be indicative of someone trying to make a forced or illegal entry and an alarm signal may be transmitted from the transmitter 57 to the paging base station 15 (Figure 1) to inform the hotel staff.

In Figures 8 to 11 of the accompanying drawings, there are shown various flow charts which illustrate the operation of the access control system and 'PAGEKEYS' herein described.

The flow chart of Figure 8 illustrates the procedure for programming the 'PAGEKEY' 23 of Figure 2, the 'PAGEKEY' 33 of Figure 3 and the programmable door lock mechanism of Figures 5 and 6.

The flow chart of Figure 9 illustrates the operation of the programmable door lock mechanism of Figures 5 and 6.

The flow chart of Figure 10 illustrates the operation of the paging base station 15 of Figure 1.

The flow chart of Figure 11 illustrates the operation of the 'PAGEKEY' 33 of Figures 3 and 4.

It should be appreciated that the embodiment of the invention which has been described has been given by way of example only and various modifications may be made whilst still utilising the basic principles thereof. For example, instead of using transmitted signals for programming the programmable door lock mechanisms they may be individually manually programmed as has been described, they may be programmed using fixed wiring between the mechanisms and a programming console, or they may be programmed through the electrical mains wiring using, for example, frequency shift keying (FSK) techniques. Also, although it is advantageous to use a transponding type 'PAGEKEY', a non-transponding type may equally well be used.

It will also be appreciated that the integrated architecture of the 'PAGEKEY' allows it to be readily used as what might be called an electronic purse, charge or credit card. In operation purchases made within the hotel environs may be recorded within the 'PAGEKEY' and debited from a pre-stored credit level or added to a running total of transaction charges.

## Claims

1. An access control device which is programmable to allow access to a restricted access area, characterised by pager means which is formed as part of said device for receiving a transmitted paging signal.

2. A device as claimed in claim 1, in the form of an electronic 'smart' card.

3. A device as claimed in claim 1 or claim 2, comprising means for affording an audible indication when a paging signal has been received.

4. A device as claimed in any preceding claim, comprising means for affording a visual indication when a paging signal has been received.

5. A device as claimed in claim 4, wherein a received paging signal is represented by illuminating a light adjacent or near to text which is descriptive of the intended message of the received paging signal.

6. A device as claimed in claim in, comprising an alpha-numeric display for displaying a received paging signal.

7. A device as claimed in any preceding claim, which is programmed with an electronic, magnetic, optical, mechanical or electrical code to allow access to a restricted access area.

8. A device as claimed in any preceding claim, which includes a transponding arrangement for receiving an interrogation signal and for transponding a predetermined code when an interrogation signal has been received to allow access to a restricted access area.

9. A device as claimed in any preceding claim, which is programmed with a paging code which determines the paging signals which are receivable by said device.

10. A device as claimed in any preceding claim, adapted to be used as an electronic data transfer device e.g. for electronic credit, charge card or data bank purposes.

11. An access control system comprising a plurality of access control devices as claimed in any preceding claim, coding means for programming each of said access control devices with an access code to allow access to a specified restricted access area, further coding means for programming each specified restricted access area with an access code which corresponds to the access code of one or more of said access control devices, and means for transmitting a coded paging signal to one or more of said access control devices.

12. An access control system as claimed in claim 11, comprising a programmable security device for restricting access to each specified restricted access area, said further coding means being effective for programming each programmable security device with an access code, each of said programmable security devices being responsive to one or more access control devices having the same code for allowing access to the specified restricted area thereof.

13. An access control system as claimed in claim 12 when claim 11 is dependent from claim 8, in which the programmable security device comprises

means for transmitting an interrogating signal when it is actuated, and means for receiving a transponded signal from an access control device which is in receipt of said interrogating signal, said programmable security device being responsive to a transponded signal from an access control device having the same access code with which it is programmed for allowing access to the restricted access area thereof.

14. An access control system as claimed in claim 12 or claim 13, in which said programmable security devices are programmed manually.

15. An access control system as claimed in claim 12 or claim 13, in which said programmable security devices are programmed remotely.

16. An access control system as claimed in claim 15, in which a signal is transmitted to said programmable security devices for programming each said programmable security device with its access code.

17. A system as claimed in any of claims 11 to 16, for use in a hotel reservation system, in which said access control devices constitute room key devices which are programmed with an access code which is also programmed into an electronic door lock associated with a specified room of said hotel to allow access to said room when the access code of said access control device corresponds to the access code of said electronic door lock, means being provided for transmitting a coded paging signal to one or more of said access control devices.

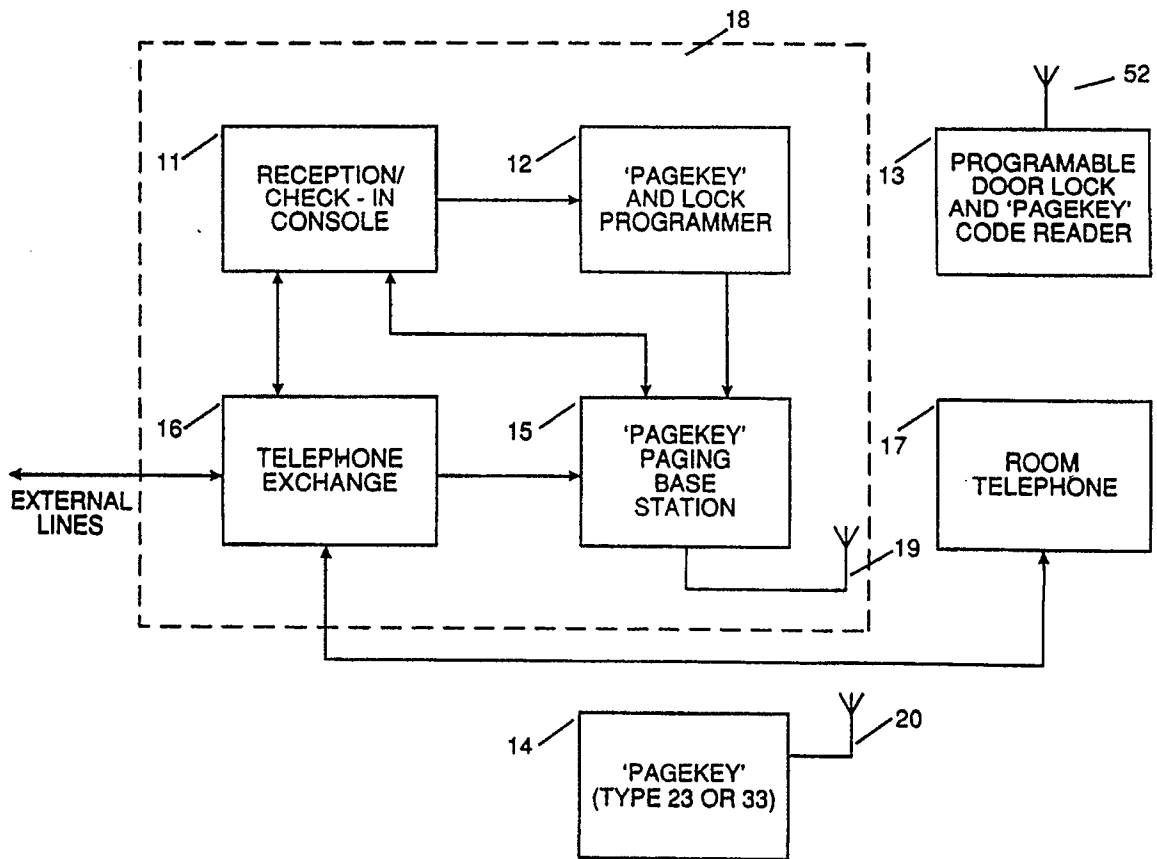

FIGURE 1

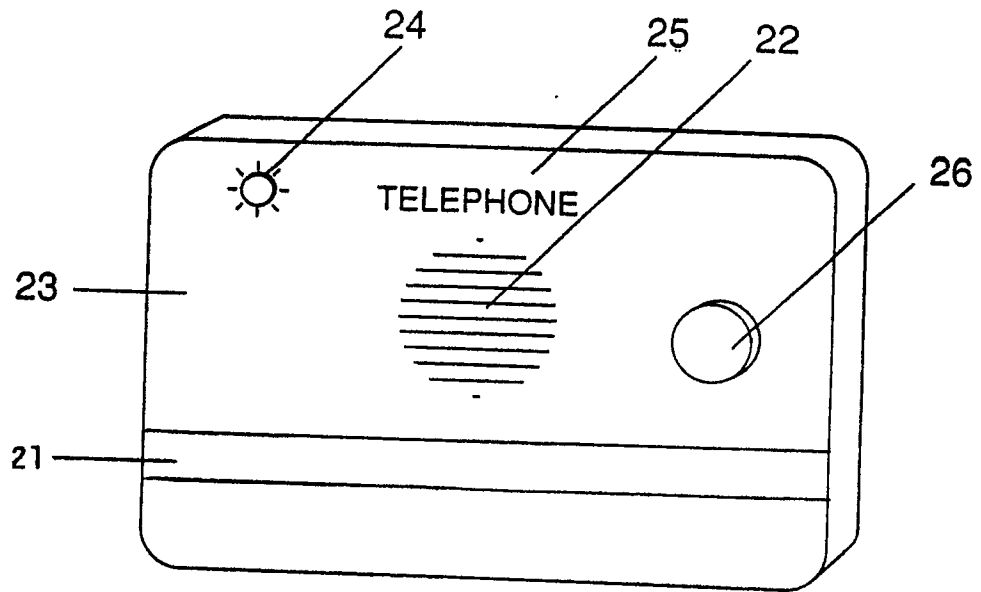

FIGURE 2

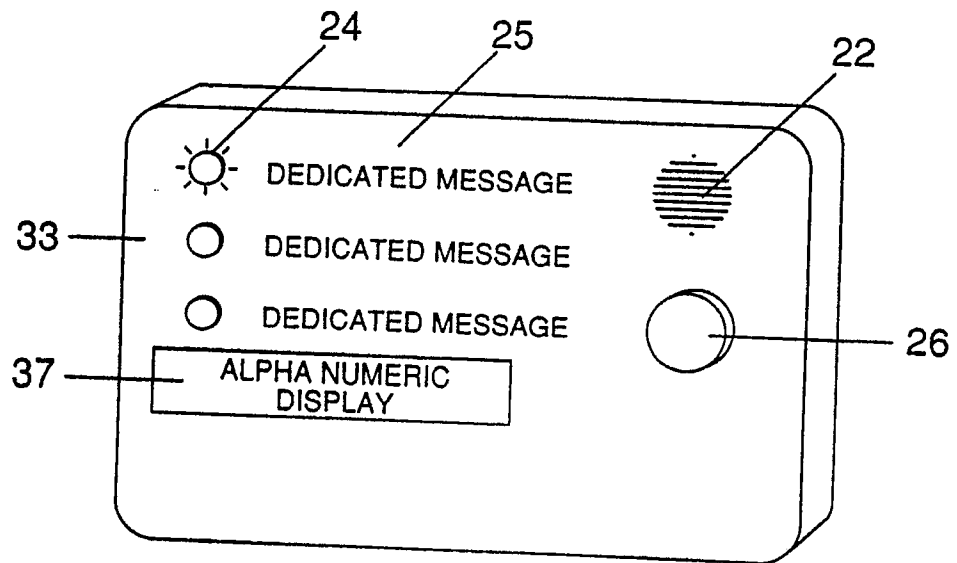

FIGURE 3

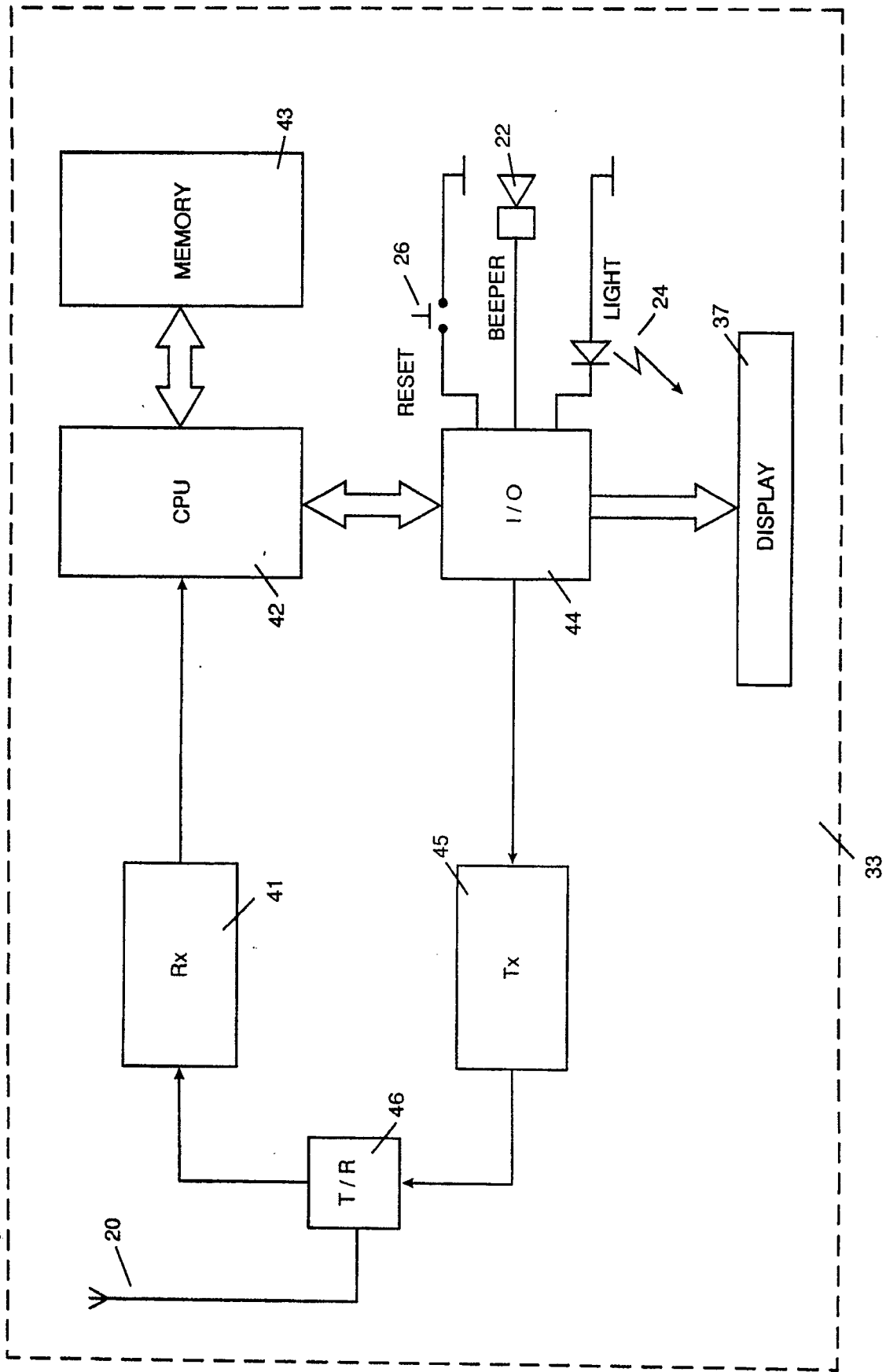

FIGURE 4

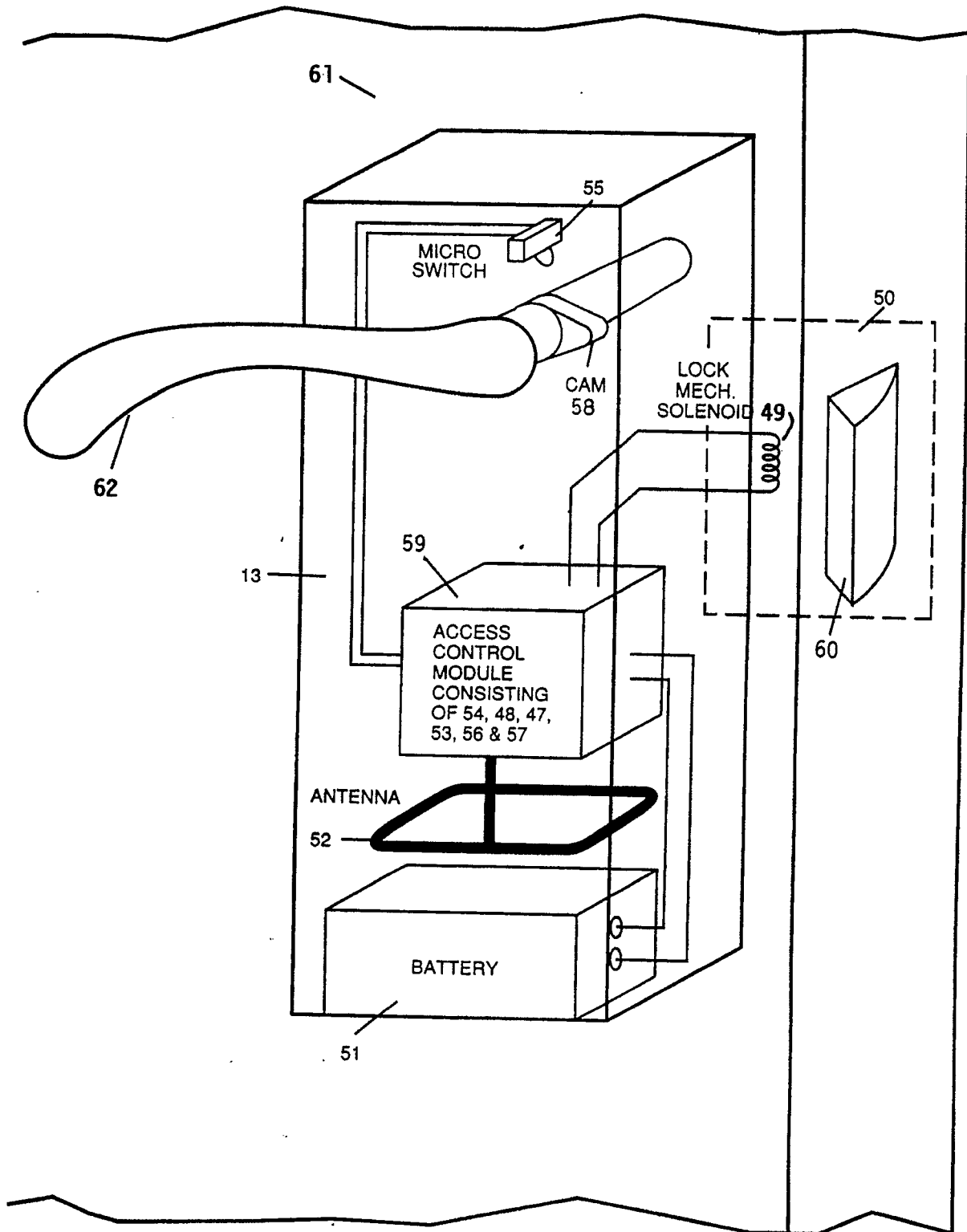

FIGURE 5

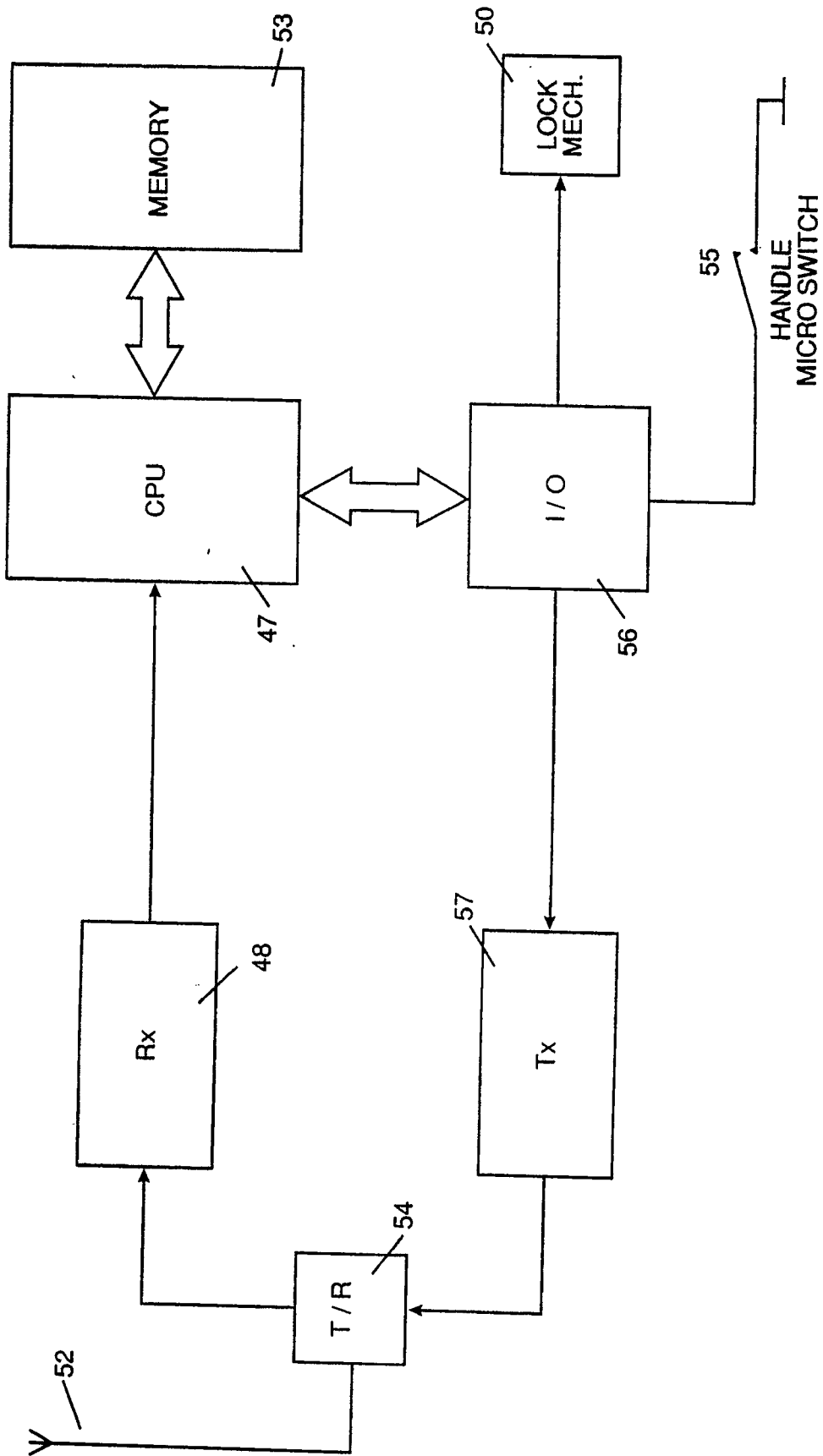

FIGURE 6

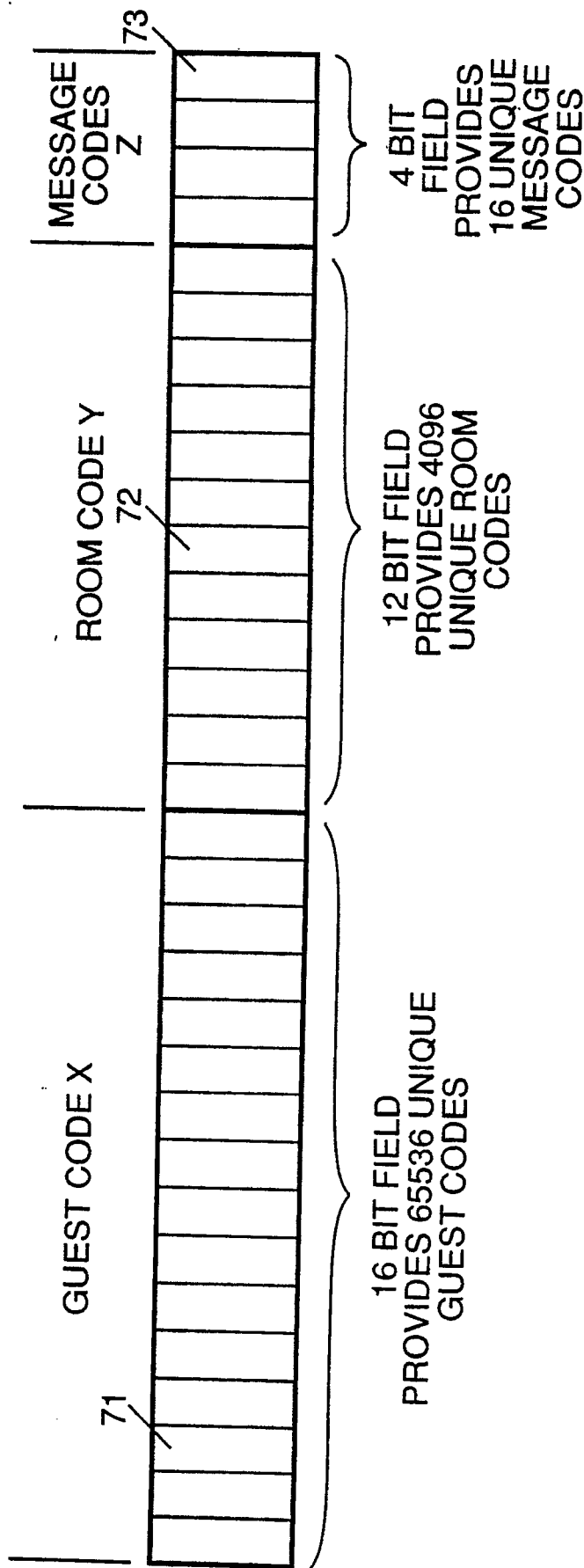

FIGURE 7

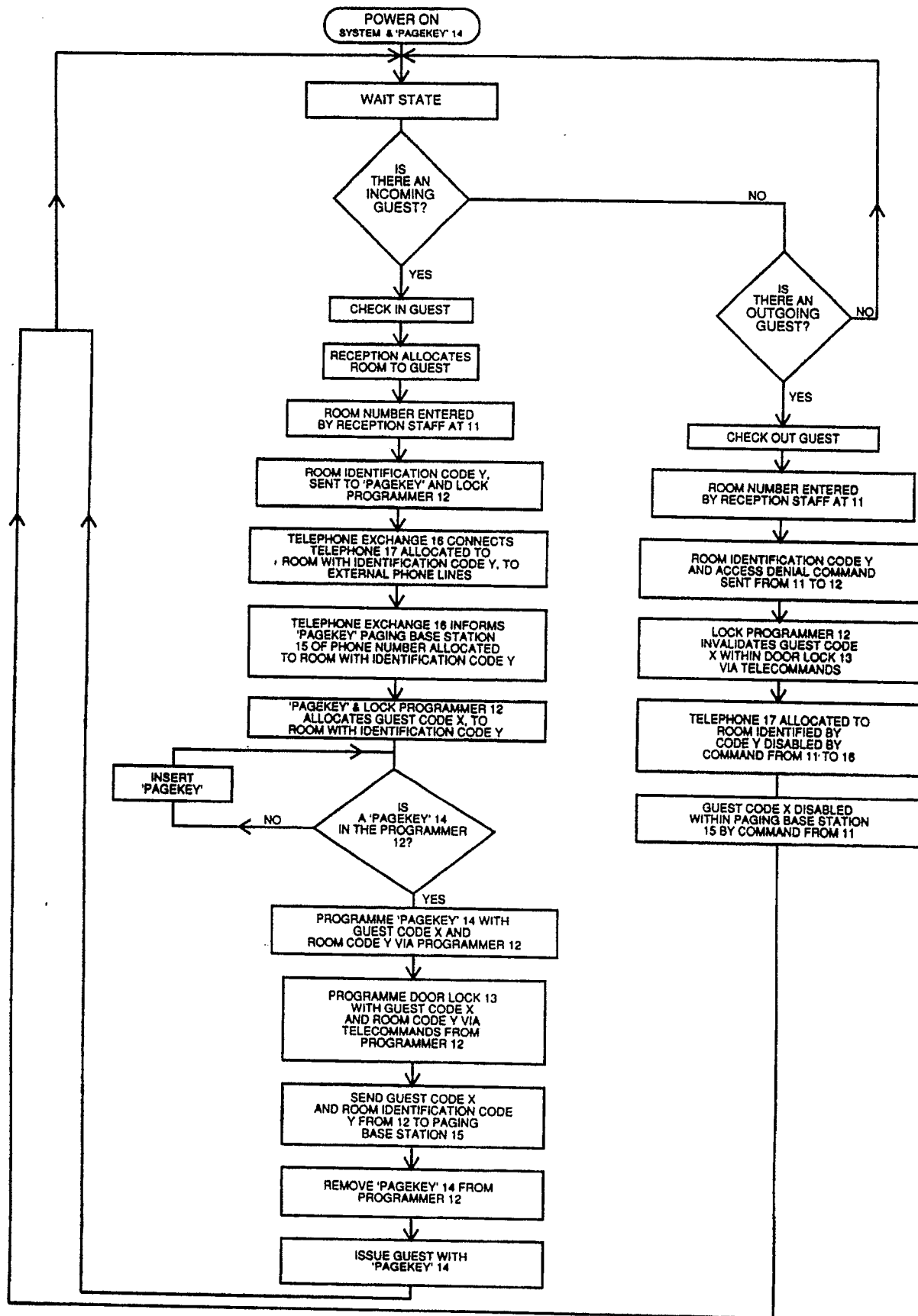

FIGURE 8

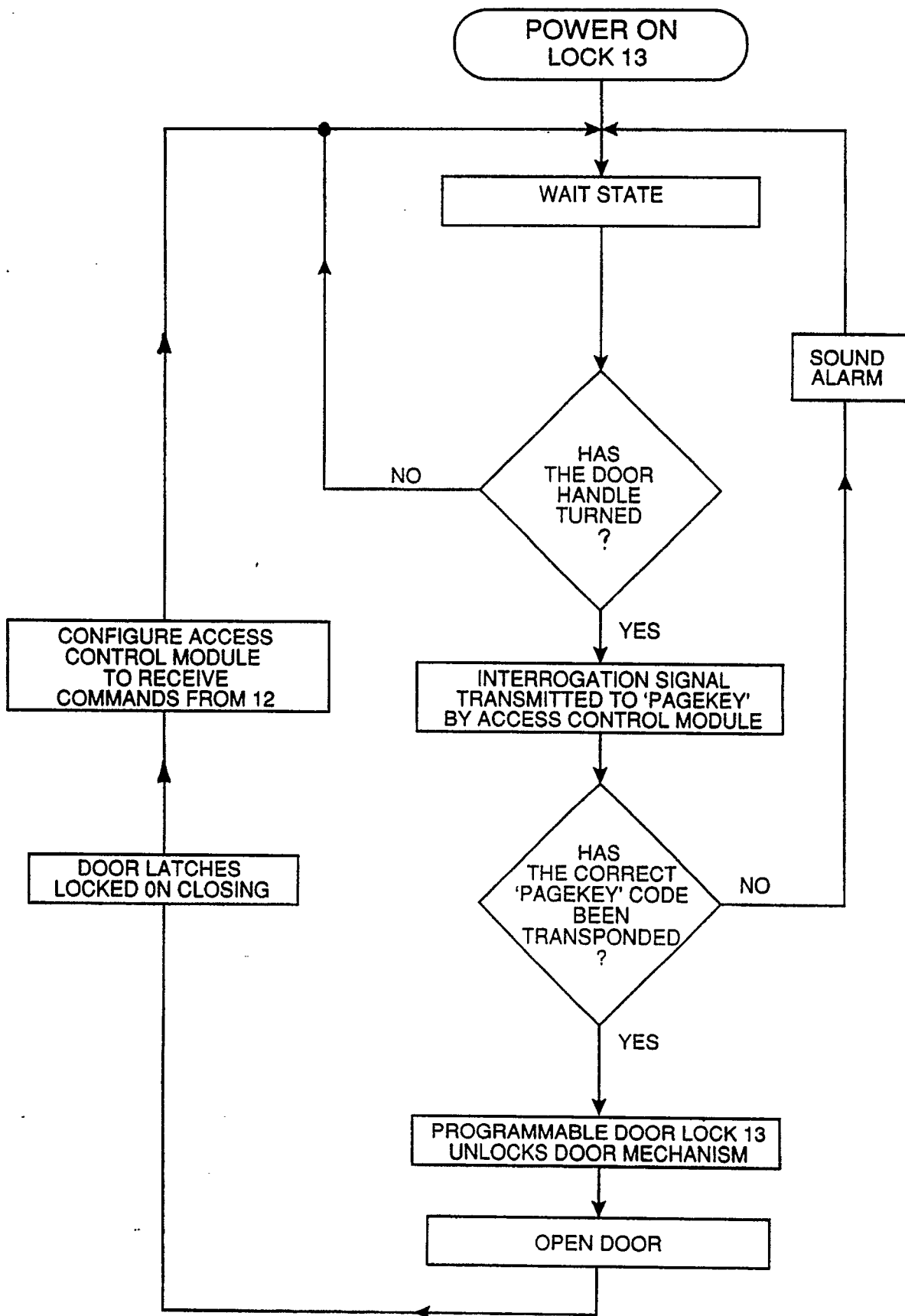

FIGURE 9

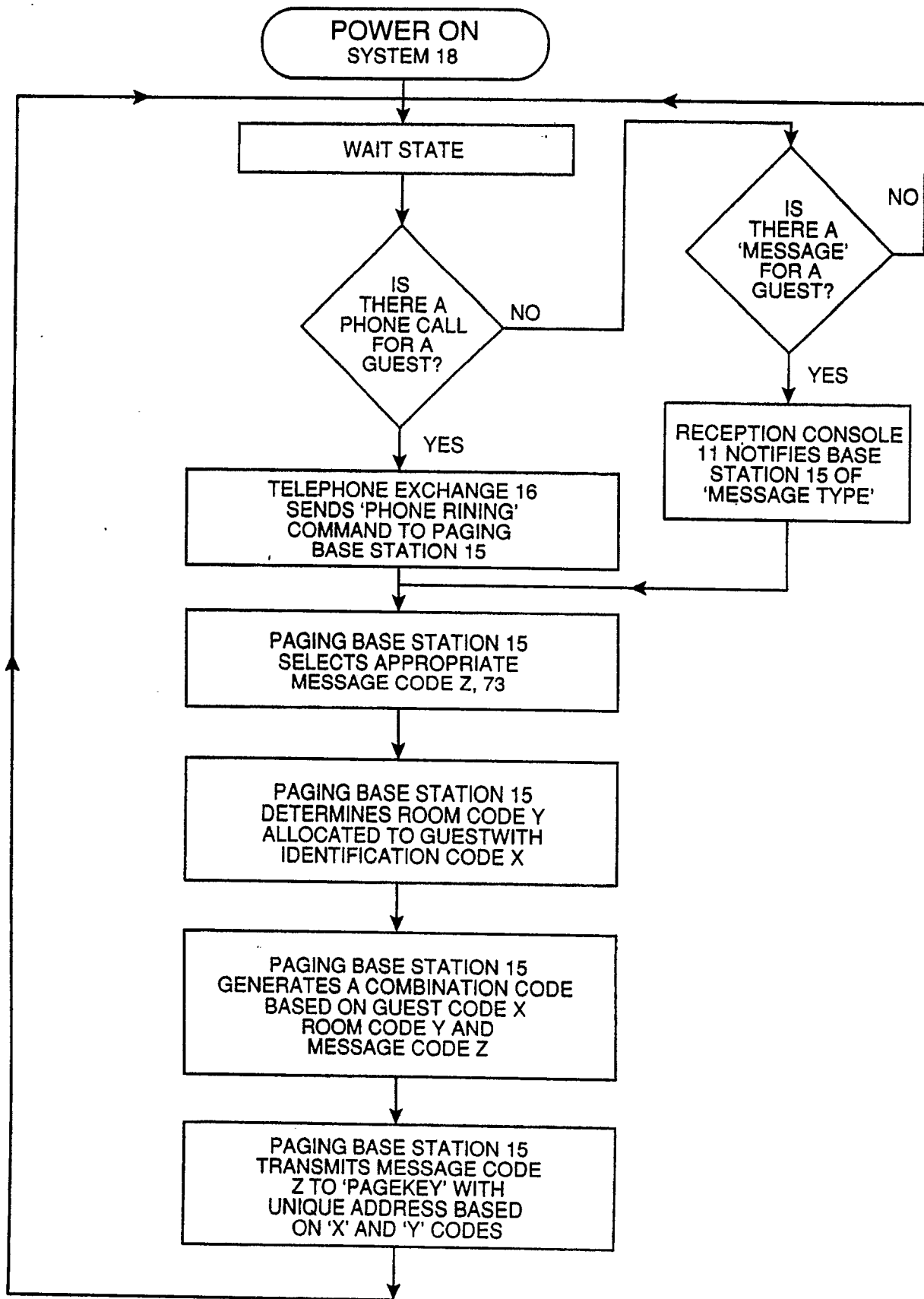

FIGURE 10

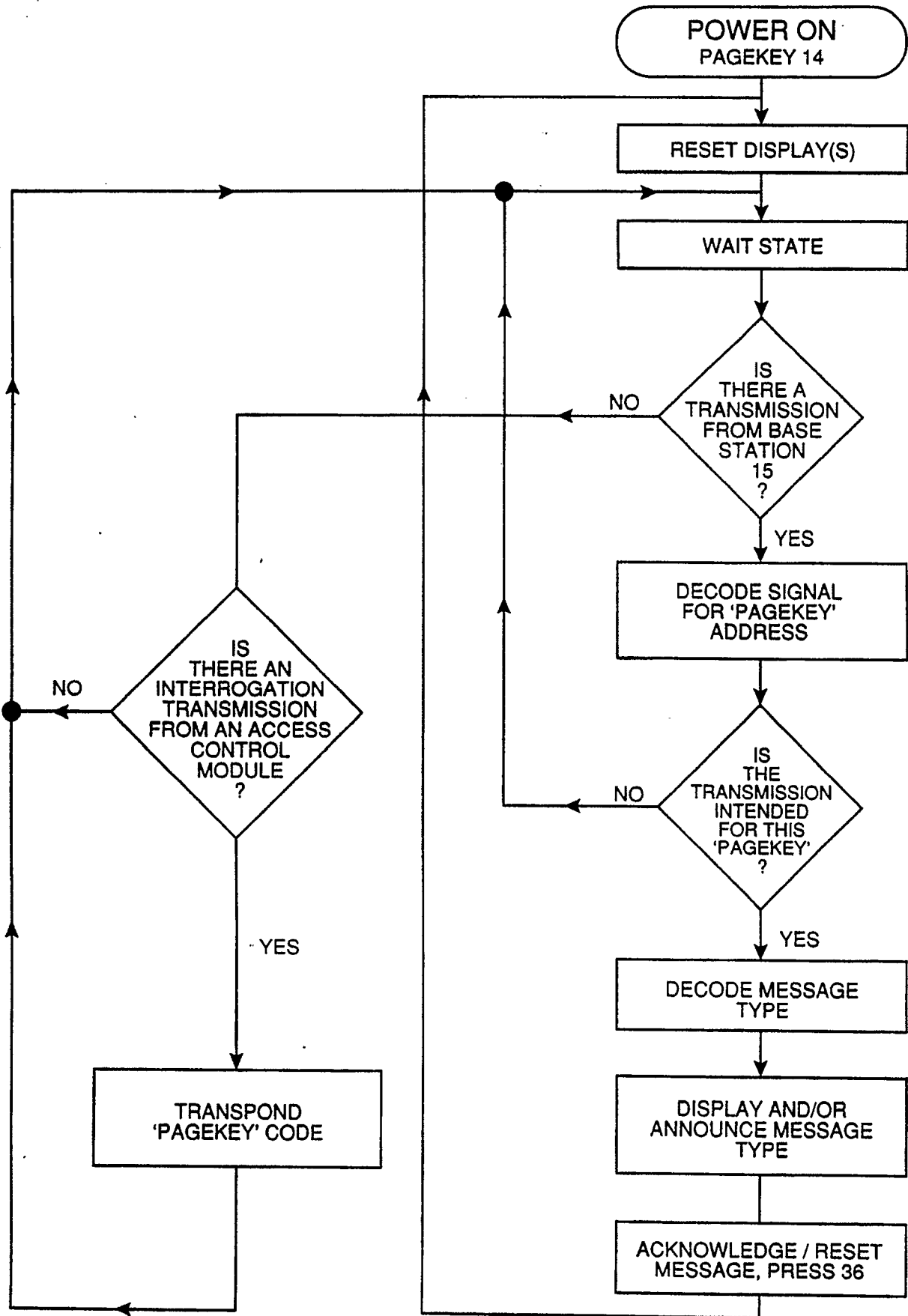

FIGURE 11