

(19) World Intellectual Property Organization  
International Bureau



(43) International Publication Date  
15 December 2011 (15.12.2011)

(10) International Publication Number  
**WO 2011/156171 A1**

- (51) **International Patent Classification:**  
E04C 2/24 (2006.01)
- (21) **International Application Number:**  
PCT/US2011/038510
- (22) **International Filing Date:**  
31 May 2011 (31.05.2011)
- (25) **Filing Language:** English
- (26) **Publication Language:** English
- (30) **Priority Data:**  
12/794,959 7 June 2010 (07.06.2010) US
- (71) **Applicant (for all designated States except US):** CERTAINTED GYPSUM, INC. [US/US]; 4300 W. Cypress Street, Suite 500, Tampa, Florida 33607 (US).
- (72) **Inventors; and**
- (75) **Inventors/Applicants (for US only):** HAUBER, Robert Joseph [US/US]; 10133 Queens Park Drive, Tampa, Florida 33647-3166 (US). BOYDSTON, Gerald D. [US/US]; 124 Siddle Drive, Cody, Wyoming 82414-9236 (US).
- (74) **Agent:** COLITZ, III, Michael J.; GrayRobinson, P.A., 201 N. Franklin Street, Suite 2200, Tampa, Florida 33602 (US).

- (81) **Designated States (unless otherwise indicated, for every kind of national protection available):** AE, AG, AL, AM, AO, AT, AU, AZ, BA, BB, BG, BH, BR, BW, BY, BZ, CA, CH, CL, CN, CO, CR, CU, CZ, DE, DK, DM, DO, DZ, EC, EE, EG, ES, FI, GB, GD, GE, GH, GM, GT, HN, HR, HU, ID, IL, IN, IS, JP, KE, KG, KM, KN, KP, KR, KZ, LA, LC, LK, LR, LS, LT, LU, LY, MA, MD, ME, MG, MK, MN, MW, MX, MY, MZ, NA, NG, NI, NO, NZ, OM, PE, PG, PH, PL, PT, RO, RS, RU, SC, SD, SE, SG, SK, SL, SM, ST, SV, SY, TH, TJ, TM, TN, TR, TT, TZ, UA, UG, US, UZ, VC, VN, ZA, ZM, ZW.
- (84) **Designated States (unless otherwise indicated, for every kind of regional protection available):** ARIPO (BW, GH, GM, KE, LR, LS, MW, MZ, NA, SD, SL, SZ, TZ, UG, ZM, ZW), Eurasian (AM, AZ, BY, KG, KZ, MD, RU, TJ, TM), European (AL, AT, BE, BG, CH, CY, CZ, DE, DK, EE, ES, FI, FR, GB, GR, HR, HU, IE, IS, IT, LT, LU, LV, MC, MK, MT, NL, NO, PL, PT, RO, RS, SE, SI, SK, SM, TR), OAPI (BF, BJ, CF, CG, CI, CM, GA, GN, GQ, GW, ML, MR, NE, SN, TD, TG).

**Published:**

— with international search report (Art. 21(3))

(54) **Title:** METHOD FOR CONSTRUCTING COMPOSITE BUILDING BOARDS USING DISSOLVABLE FILMS

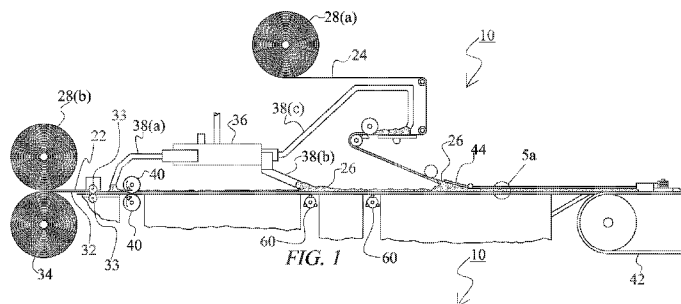

(57) **Abstract:** Disclosed are building board manufacturing techniques that minimize the build-up of slurry on associated forming equipment and also produce panels with enhanced physical properties. The methods involve applying a dissolvable film laminate to one or more fiber mats at the outset of the forming process. In the un-dissolved state, the film acts as a containment envelope for the gypsum slurry and any free floating glass fibers. During subsequent curing, the film is dissolved by vaporized water. In its dissolved state, the film is liquefied and coats the fibers of the underlying mat. This results in a building board with improved physical properties.

WO 2011/156171 A1

# METHOD FOR CONSTRUCTING COMPOSITE BUILDING BOARDS USING DISSOLVABLE FILMS

## CROSS REFERENCE TO RELATED APPLICATION

5 [1] This application claims the benefit of priority to U.S. Patent Application Serial Number  
12/794,959, filed on June 7, 2010 and entitled "Method for Constructing Composite Building  
Boards Using Dissolvable Films", the contents of which are incorporated herein.

## BACKGROUND OF THE INVENTION

### Field of the Invention

10 [2] This invention relates to a method for constructing composite building boards. More  
particularly, the present invention relates to the use of dissolvable films in the construction of  
composite gypsum building boards.

### Description of the Background Art

15 [3] Building board, also known as wallboard, plasterboard, or drywall, is one of the most  
commonly used building components in the world today. Building board is frequently used  
within the interior of a dwelling, where it functions both as a finished wall covering and as a  
structural room partition. Building board can also be used on the exterior of a dwelling, where  
it serves as a sheathing to provide weather protection and insulation. Building board can also  
be used as an interior facing for other structures as well, such as stairwells, elevator shafts,  
and interior ducting.

20 [4] One particularly popular form of building board is known as glass reinforced gypsum  
(GRG) board. An example of one such board is disclosed in U.S. Patent No. 4,265,979 to  
Baehr et. al. Baehr discloses a building board constructed from opposing glass fiber mats  
with an intermediate gypsum core. This construction provides a hardened external surface  
and is an improvement over earlier paper faced boards.

25 [5] Current GRG manufacturing techniques have some significant drawbacks. Namely,  
during construction, some of the individual mat fibers are not covered by the gypsum slurry  
core and are therefore exposed. These fibers have a tendency to dry out and disengage  
from the board. As a result, free floating glass fibers tend to accumulate on and damage  
associated forming equipment, such as forming tables, forming plates, motor drives,  
30 bearings, and the like. The presence of disengaged fibers also presents a significant hazard

to workers who must wear appropriate safety masks so as not to ingest the fibers. The most common way to combat this problem is through the use of expensive dust collection equipment and/or the periodic and repeated cleaning of the forming equipment.

5 [6] A subsequent board manufacturing technique is described in commonly owned U.S. Patent No. 4,378,405 to Pilgrim. The contents of the Pilgrim patent are fully incorporated herein by reference. Pilgrim discloses a GRG board that is faced on one or both sides with a porous, nonwoven glass mat. The glass mat of Pilgrim is slightly embedded into the slurry core. This is accomplished by vibrating the gypsum slurry to cause it to pass through the porous openings in the mat. Embedding the mat within the core as taught in Pilgrim results  
10 in a thin film of slurry being formed on the outer surface of the board. Building boards with this construction are referred to as embedded glass reinforced gypsum (EGRG) boards.

[7] EGRG boards eliminate, or greatly reduce, the presence of exposed fibers and greatly reduce the presence of free floating fibers. However, the construction of EGRG boards also has its drawbacks. Namely, EGRG boards require the application of large amounts of gypsum slurry. This slurry leaks from the boards during manufacture and accumulates on  
15 associated forming equipment. Thus, during manufacture, the forming tables, forming belts, and associated rollers and motors are exposed to substantial build-ups of gypsum slurry. Over time, if not repeatedly cleaned, the manufacturing process comes to a complete stop. Thus, in traditional GRG and EGRG building board manufacturing techniques there is a  
20 substantial capital investment in equipment designed to clean the forming areas.

[8] Additionally, even in the construction of EGRG boards, there is a continuing problem with some fibers becoming exposed, dried and detached. This, in turn, results in the accumulation of free fibers on the forming tables, forming belts and associated rollers and  
25 motors. As with the excess gypsum slurry, these fibers must be removed in order to prevent downtime.

[9] During the drying of GRG boards, excess water in the gypsum core is boiled off and passes through the facing mats. These vapors serve to breakdown and weaken binders within the mats and surrounding core. This, in turn, releases silica-based granules that are likewise damaging to forming tables, forming belts, and associated rollers and motors. This,  
30 too, leads to the need for periodic cleaning and maintenance.

[10] Thus, there exists a need in the art for improved building board manufacturing techniques. More specifically, there is a need in the art for manufacturing techniques that minimize the acumination of gypsum slurry and/or free floating fibers on associated forming equipment. There also exists a need to minimize capital investment needed to construct GRG and EGRG building boards. There is yet another need to economically produce GRG and EGRG building boards with improved physical characteristics. The present invention is aimed at achieving these objectives.

#### SUMMARY OF THE INVENTION

[11] It is therefore one of the objectives of this invention to manufacture building boards in a way that minimizes the accumulation of slurry on associated forming equipment.

[12] It is also an object of this invention to construct fiber reinforced building boards via techniques that minimize and/or eliminate the presence of exposed and/or free floating fibers.

[13] It is still yet another object of this invention to utilize a dissolvable film during the manufacture of building boards.

[14] Another object of this invention is to use a dissolvable film in the construction of building boards, where in the un-dissolved state, the film acts as a containment envelope for slurry and glass fibers.

[15] Still yet another object of this invention is to use a dissolvable film in the construction of building boards, where the dissolved film improves the physical properties of the resulting building board.

[16] The foregoing has outlined rather broadly the more pertinent and important features of the present invention in order that the detailed description of the invention that follows may be better understood so that the present contribution to the art can be more fully appreciated. Additional features of the invention will be described hereinafter which form the subject of the claims of the invention. It should be appreciated by those skilled in the art that the conception and the specific embodiment disclosed may be readily utilized as a basis for modifying or designing other structures for carrying out the same purposes of the present invention. It should also be realized by those skilled in the art that such equivalent

constructions do not depart from the spirit and scope of the invention as set forth in the appended claims.

#### BRIEF DESCRIPTION OF THE DRAWINGS

[17] For a fuller understanding of the nature and objects of the invention, reference should be had to the following detailed description taken in connection with the accompanying drawings in which:

[18] Fig. 1 is an elevational view of the first part of the manufacturing process wherein the slurry is applied to fiber mats;

[19] Fig. 2 is an elevational view of the second part of the manufacturing process wherein the building boards are cut and flipped;

[20] Fig. 3 is an elevational view of the third part of the manufacturing process wherein the building boards are delivered into a series of dryers;

[21] Fig. 4 is a cross section of the fourth part of the manufacturing process wherein the building boards exit with a previously applied film dissolved;

[22] Fig. 5A is a detailed cross section of the building board taken from Figures 1 and 2.

[23] Fig. 5B is a detailed cross section of the building board taken from Figure 2.

[24] Fig. 5C is a detailed cross section of the building board taken from Figure 4.

Similar reference characters refer to similar parts throughout the several views of the drawings.

#### DETAILED DESCRIPTION OF THE PREFERRED EMBODIMENT

[25] The present disclosure relates to building board manufacturing techniques that minimize the build-up of slurry on associated forming equipment and that also produce panels with enhanced physical properties. The method involves applying a dissolvable film to one or more fiber mats at the outset of the forming process. In the un-dissolved state, the film acts as a containment envelope for the slurry and any free floating glass fibers. During subsequent curing, the film dissolves when heated and by the passage of vaporized water through the film. In its fully dissolved state, the film coats any exposed fibers and sinks down into the slurry core. This eliminates exposed fibers and produces building boards with enhanced physical properties. The disclosed method can be utilized in the production of GRG or EGRG boards.

[26] The present method is carried out via a building board production line **10**. The various sections of this line are sequentially illustrated in Figures 1-4. The various components of the building boards are assembled in the first stage illustrated in Figure 1. As is known in the art, conventional GRG/EGRG building boards are formed from one or more glass fiber mats that are lined with a gypsum slurry. In the depicted embodiment, first and second glass fiber mats (**22** and **24**, respectively) are adhered to opposing sides of a slurry core **26**. Slurry core **26** is preferably formed from a gypsum slurry. Mats **22** and **24** are dispensed from upper and lower rolls (**28(a)** and **28(b)**, respectively).

[27] The mats are preferably constructed from a series of nonwoven, randomly aligned glass fibers. The mats are also preferably pre-coated with an organic or inorganic resin binder to hold the individual fibers together. However, the disclosed method can be carried out with a variety of other mat constructions. For instance, the mats can be formed from woven or non woven filaments of organic and/or inorganic fibers. Continuous or non-continuous filament fibers can likewise be used. Additionally, the mats can be supplied uncoated, with the resin binder being applied at a point along the production line **10**.

[28] As illustrated in Figure 1, the lower glass mat **22** is supplied to a forming table via lower mat roll **28(b)**. Figure 1 also illustrates a film **32** being adhered to the underside of lower glass mat **22** prior to application of gypsum slurry **26**. Glass mat **22** is referred to as being the "lower" glass mat in that it is initially beneath the upper mat **24** during the assembly process. However, it is understood that during subsequent processing mat **22** is cut into individual boards, which are then inverted or flipped. As such, lower glass mat **22** eventually becomes an upper glass mat **22**; namely, after being flipped, mat **22** is oriented over mat **24**. Additionally, although underlying film **32** initially faces the forming table, it is eventually exposed after the board is flipped.

[29] A variety of materials can be used for film **32**. In the preferred embodiment, film **32** is a water soluble, synthetic polymer, such as a Polyvinyl Alcohol ("PVOH"). PVOH films are preferred because they are temperature sensitive, reactive to water, and gas permeable during phase change, and heat curable. In the preferred embodiment, PVOH film **32** is between approximately .5 and 2.5 mils thick. By way of non-limiting example, a PVOH film **32** having a thickness of approximately 1.8 mil is preferred. One suitable PVOH film is made

by Monosol<sup>®</sup> of Portage, Indiana. Other water and/or heat dissolvable films can be utilized by the present method. For example, certain water dissolvable polyethylene-based composite films produced by Aicello Chemical Co., Ltd. of Toyohashi, Japan have been found to be acceptable. Alternatively, heat dissolvable films may also be used such as certain Ethylene Vinyl Alcohol ("EVA") films. Still yet other films that dissolve in the presence of heat and/or water may suffice.

[30] The film **32** is stored in a roll **34** and is applied via a slip sheet. Proper adherence is achieved by delivering mat **22** and film **32** through opposing hot laminating rollers **33**. It is preferred that the width of film **32** be equal or slightly greater than to the width of glass mat **22** to ensure that the entire undersurface of glass mat **22** is covered by film **32**. After being passed through the hot laminating rollers **33**, film **32** preferably has a tackiness that assists in adhering film **32** to mat **22**. Alternatively, film **32** is formed from a material that does not interfere with proper adherence between film **32** and mat **22**. The tackiness of film **32** also assists in adhering the upper mat **24** to the folded edges of lower mat **22** during subsequent processing as described below. As noted hereinafter, upper mat **24** may or may not include a film layer **32**.

[31] Film **32** can also be adhered to mat **22** by way of a heat activated adhesive. This adhesive can be applied to mat **22** prior to unrolling the mat **22** in the gypsum board manufacturing process. This would allow film **32** to be laminated to mat **22** via a simple low cost heated roller or compression nip. Suitable adhesives include a hot melt polyolefin adhesives. Ethylene vinyl acetate (EVA) adhesives can likewise be used. Organic and/or inorganic cold thermal setting or hot applied thermoplastic adhesives can likewise be utilized.

[32] Alternatively, film **32** can be coated with a suitable heat activated adhesive along production line **10** prior to film **32** being secured to mat **22**. The preferred adhesive in this instances would be a tacky adhesive with a long open time. In still yet another embodiment, film **32** could be laminated to glass mat **22** prior to in-plant use. Namely, mat **22** would be received by the plants with film **32** already laminated to it.

[33] Once film **32** is laminated to mat **22** one or more layers of gypsum slurry **26** are then applied to the upper surface of lower mat **22**. In the depicted embodiment, a mixer **36** supplies a series of gypsum slurry layers to mat **22**. In the depicted embodiment, slurry **26** is

supplied from mixer **36** via outlets **38(a)**, **38(b)**, and **38(c)**. The first slurry layer is supplied via outlet **38(a)**. The slurry can be applied at varying densities, and/or with varying additives, from the different outlets **38(a)**, **38(b)**, and **38(c)**. A similar slurry application technique is described in commonly owned U.S. Pat. 6,878,321 to Hauber et. al. and entitled "Method of Manufacture of Glass Reinforced Gypsum Board and Apparatus Therefor." The contents of this commonly owned patent are fully incorporated herein.

[34] Prior to the application of slurry at outlet **38(a)**, the edges of mat **22**, along with the secured film **32**, can be folded upwardly via crimping rollers to create a containment envelope at the edges of the board. This prevents, or greatly lessens, the amount of slurry that leaks from the sides of the board during subsequent processing. A suitable edge folding mechanism is disclosed in commonly owned U.S. Pat. 6,524,679 to Hauber. The contents of this patent are fully incorporated herein.

[35] In the production of EGRG boards, after slurry is supplied at outlet **38(a)**, mat **22** passes through a pair of opposing roller coaters **40**. Roller coaters **40** function in assuring that slurry **26** penetrates glass mat **22** and coats the individual fibers. During this penetration, film **32** functions as a containment envelope and prevents slurry from leaking through the bottom of mat **22** and contaminating the underlying forming table. Roller coaters **40** also ensure that a dense slurry layer **30** is formed between lower mat **22** and film **32**(note Fig. 5a). The slurry density achieved by roller coaters **40** is greatly improved via the containment functions of the film **32** and folded edges. The increased density, in turn, allows for better slurry penetration and the near total embedment of mat fibers.

[36] However, the method disclosed herein can also be utilized in the production of GRG boards, such as the boards disclosed in U.S. Pat. 4,265,979. In this embodiment, gypsum core **26** is applied over top of mat **22** but does not fully penetrate mat **22**. This lack of penetration results in voids being present along the boundary of film **32** and underlying mat **22**. Some of these voids are subsequently filled with slurry from core **26**. However, because mat **22** is not fully embedded, some voids are present in the finished board. This results in a board with less adherence and a looser bond between film **32** and mat **22**.

[37] After the application of slurry at outlet **38(a)**, and as illustrated in Figure 1, a forming belt **42** transports the partially formed board to a second slurry outlet **38(b)** where a second layer



of gypsum slurry **26** is applied directly over the first layer. As noted above, slurry supplied by outlet **38(b)** is preferably less dense than the slurry provided at outlet **38(a)**. Vibrators **60** underlying the forming table can be employed to remove any air voids and to ensure mat **22** is completely embedded within slurry **26**. This second layer forms the major part of the slurry core **26**. During the application of slurry, in multiple layers or otherwise, the un-dissolved film laminate **32** continues to act as a containment envelope to prevent slurry from leaking onto the underlying forming equipment.

[38] With continuing reference to Figure 1, an upper glass fiber mat **24** is applied to the exposed slurry to form a composite panel. Upper glass mat **24** is supplied from an additional glass mat roll **28(a)** and associated guide rollers. In the disclosed embodiment, mats **22** and **24** have an identical construction. However, depending upon the desired application, it is within the scope of the present invention to use differing constructions for mats **22** and **24**. It is also within the scope of the present invention to employ a PHOV film **32** overtop of mat **24**. Such a film would be applied prior to mat **24** being delivered to associated roller coaters and would otherwise be adhered in a fashion similar to the application of film **32** to mat **22** as described above. However, in the preferred embodiment depicted in Figures 1-5, film **32** is limited to lower mat **22**.

[39] A layer of slurry is thereafter applied to the face of mat **24** via slurry outlet **38(c)**. Slurry from outlet **38(c)** can be applied at a separate forming table if desired. Again, slurry from outlet **38(c)** can have a higher density than the slurry from outlet **38(b)**. As described above in connection with EGRG board production, roll coaters can be used to force the slurry through mat **24** to create a thin surface layer of slurry **30**.

[40] Upper mat **24** (with or without an adhered film layer **32**) is then delivered via transfer rollers over top of slurry core **26** and the lower mat **22** to form a composite panel. In the event edges of mat **22** are folded, the lateral edges of mat **24** are adhered to the folded edges of mat **22**, with the tackiness of film **32** functioning as an adhesive. Alternatively, an adhesive can be applied between the lateral edges of mat **24** and the folded edges of mat **22**.

[41] The composite panel is then delivered to a forming plate **44**. Forming plate **44** further compacts the applied slurry and constrains the panel to a desired thickness. During this

process, additional slurry is forced through and over underlying mat **22**. Excess slurry is prevented from contacting the underlying forming belt **42**, associated drives, bearings, and other surfaces by the way of the un-dissolved film **32**. Film **32** continues to perform this containment function as the board travels along the various stages of production line **10**.

5 [42] Next, as illustrated in Figure 2, forming belt **42** routes the panel to a roller section **48** and an associated cutting station. At the cutting station, knives **50** cuts the panel into a number of discrete building boards of a desired length. The building boards can be cut into any length that is desired for various purposes. The individual boards are then passed along accelerator belts **52** to a flipping table **54**. At flipping table **54**, the individual building boards  
10 are turned over. As a result, film **32** underlying lower (or first) glass mat **22** is exposed (compare Figs. 5a and 5b). Likewise, upper (or second) glass mat **24** and covering gypsum layer **30** are placed in facing relation with the forming belt **42** following flipping table **54**.

[43] As noted in Figure 3, a transfer table **58** delivers the individual boards to the infeed section **62** of the first dryer zone **64(a)**. It is important to maintain the integrity of film **32** prior  
15 to the boards being delivered to the infeed section **62** of dryers **64**. Namely, film **32** should remain non-porous as the boards are being transferred and flipped. Maintaining film integrity ensures that wet slurry does not come into contact with the forming equipment as noted above.

[44] Thereafter, as is conventional in the manufacture of gypsum building products, a series  
20 of dryers are utilized to heat the gypsum within the panels and vaporize any non-crystalline water. In the depicted embodiment, there are four dryer zones **64(a)**, **64(b)**, **64(c)** and **64(d)**. However, the number of dryer zones employed is not critical to the present invention. Dryers **64** are designed to heat the building boards to a degree sufficient to cure the gypsum. This is typically achieved at a temperature of approximately 212°F. The presence of entrained water within the gypsum core will generally prevent the temperature of the gypsum core from  
25 raising above 212 °F. Dryers **64** of the depicted embodiment utilize a conventional construction and run at temperature levels that range anywhere between approximately 650 °F to 180 °F, which is typical for gypsum drying operations.

[45] As a result of this heating process, water is vaporized and delivered upwardly through  
30 film **32**. PVOH films are advantageous because they become porous when heated, thereby

allowing water vapor to escape and avoiding blistering. The escaping water vapor, and the exothermic nature of gypsum rehydration, also furthers the dissolution of the PVOH film. Thus, the dissolution characteristics of PVOH films are dependent upon time and exposure to heat and water vapor. In the context of a board dryer, PVOH films start to become permeable at approximately 60°F and achieve total permeability at approximately 212°F. Other films can be chosen to achieve total film dissolution at between 110°F and 120°F. Films that have no dissolution state, or that are less porous, are not desirable because they do not adequately allow for the passage of vaporized water and therefore result in blistering.

[46] The passage of water vapor through film **32** serves to liquefy the film **32**. This, in turn, results in the liquefied PVOH film melting downwardly over mat **22** (note Fig. 5c). Embedding mat **22** within core **26** serves to coat most, but not all, of the exposed fibers of mat **22**. Any fibers left exposed after embedment are subsequently completely coated by dissolved film **32**. This prevents the disengagement of loose fibers.

[47] The dissolved PVOH film also sinks into the face of the board and is partially absorbed by gypsum core **26**. After film **32** has been absorbed, the PVOH film **32** may chemically bond with other polymers additives within core **26**. Such bonding may be accomplished during curing. In still yet other embodiments, film **32** includes polymer additives that bond to additives within gypsum core **26**. These additives can be selected to enhance any of a variety of physical properties and may impart, for example, increased board strength, water resistance, mould protection, and or ultraviolet protection.

[48] By the end of the fourth dryer zone **64(d)**, film **32** is completely dissolved. Depending on the composition of film **32**, it may be translucent, partially translucent, or opaque upon dissolution. A coloring can also be imparted to the board by way of film **32**. The application of the liquefied PVOH film to the panel provides a smoother finish and results in a building board with superior water resistance. In the preferred embodiment, the resulting board has a moisture resistance that meets the American Society of Testing and Materials standard ASTM-C 1177. The resulting board has a smoother texture by virtue of film **32** and therefore exhibits improved bonding to paints and joint compounds.

[49] The method described above utilizes a dissolvable film **32** in the construction of GRG or EGRG building boards. However, the method can also be applied to other building board

5 constructions. Film **32** has primarily been disclosed as a containment envelope with the film integrity being maintained at all points prior to the boards being dried. Namely, film **32** can be adhered to mat **22** via an adhesive, with film **32** being dissolved in the presence of water vapor and at a temperature at or above 212°F. However, the present method also allows for the controlled dissolution of film **32** at any point in the process. For instance, film **32** can be used as a slip sheet between the board and underlying forming table. Film **32** can also be made from materials that dissolve as a result of the exothermic reaction and/or water condensation associated with setting gypsum. More specifically, film **32** can be selected to realize complete film dissolution at any point during the process. This dissolution point can be selected based upon the specific objectives of the manufacturing process. For example, in certain circumstances the gypsum may be cured prior to passage through one or more driers. This may be carried out, for instance, via known ultraviolet (UV) curing processes. In this instance, it would be desirable to affect dissolution of film **32** at an earlier point during the board manufacturing process.

10 [50] The present disclosure includes that contained in the appended claims, as well as that of the foregoing description. Although this invention has been described in its preferred form with a certain degree of particularity, it is understood that the present disclosure of the preferred form has been made only by way of example and that numerous changes in the details of construction and the combination and arrangement of parts may be resorted to without departing from the spirit and scope of the invention.

20 Now that the invention has been described,

WHAT IS CLAIMED IS:

1. A method for the manufacture of composite building boards formed from first and second mats of non-woven, randomly aligned glass fibers and an intermediate gypsum core, the method comprising the following steps:

5 adhering a PVA film to a lower surface of the first mat, the PVA film being completely dissolvable in the presence of heat and water;

pouring a layer of gypsum slurry over an upper surface of the first mat, the slurry penetrating the first mat but being retained by the PVA film;

10 applying the second mat to the gypsum slurry layer, the first and second mats and intermediate gypsum slurry forming a composite panel;

15 passing the composite panel along a forming belt, wherein the PVA film functions as a containment envelope to prevent the accumulation of gypsum slurry on the forming belt;

cutting the composite panel into composite building boards of desired lengths;

flipping the composite building board, whereby PVA film the is exposed and the second mat faces the forming belt;

20 heating the composite building boards in a series of dryers to cure the gypsum slurry, wherein during the curing process entrained water within the gypsum slurry is vaporized and passes through the exposed PVA film;

dissolving the PVA film via heat from the dryers and the vaporized water, the dissolved film flowing over and adhering to the fibers of the first mat to thereby enhance the physical properties of the composite building boards.

2. A method for the manufacture of composite building board comprising the following steps:

applying a dissolvable film to a surface of a porous mat;

25 pouring a layer of wet slurry over the porous mat, the wet slurry penetrating the porous mat but being retained by the film;

passing the porous mat along a belt, wherein the film prevents the accumulation of wet slurry on the belt;

heating the porous mat and wet slurry, wherein the wet slurry is dried and the film is dissolved.

30 3. The method as described in claim 2 wherein the film is dissolved by the heat applied to

the porous mat and wet slurry.

4. The method as described in claim 2 wherein the film is dissolved by water escaping from the wet slurry.

5

5. The method as described in claim 2 wherein the film is a PVA laminate.

6. The method as described in claim 2 further comprising the step of applying a second porous mat over the wet slurry, wherein the first and second porous mats and intermediate wet slurry form a composite panel.

10

7. The method as described in claim 2 further comprising the step of liquefying the film such that it flows over and adheres to the porous mat to thereby enhance the physical properties of the composite building board.

15

8. A method for the manufacture of building board comprising the following steps:  
applying a dissolvable film to a surface of a porous mat;  
pouring a layer of wet slurry over the porous mat, the wet slurry penetrating the porous mat but being retained by the film;

20

passing the porous mat along a belt, wherein the film prevents the accumulation of wet slurry on the belt;

dissolving the film, whereby the dissolved film enhances the physical properties of the building board.

25

9. The method as described in claim 8 wherein the film is a PVA laminate.

10. The method as described in claim 8 wherein the film is an EVA laminate.

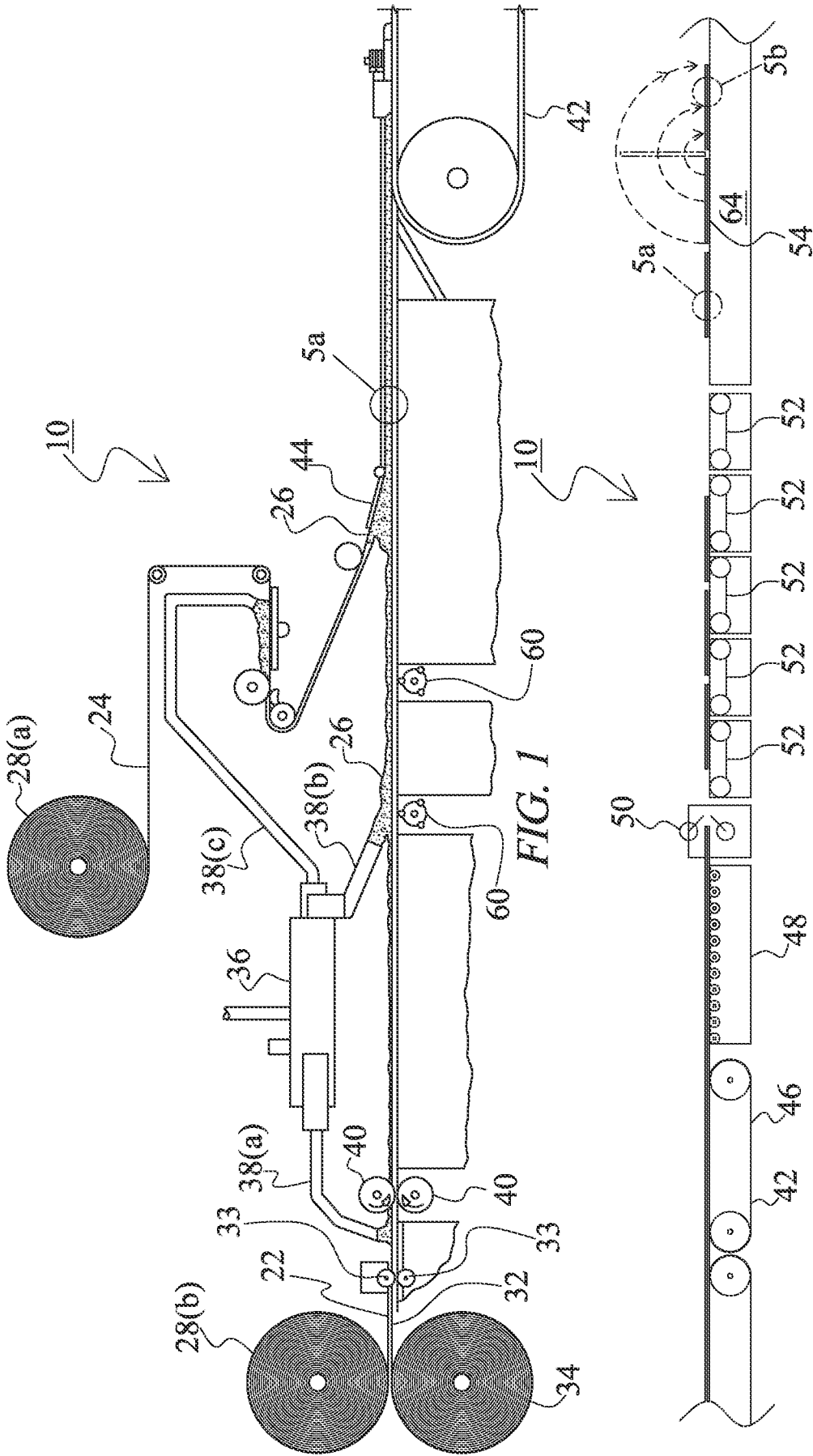
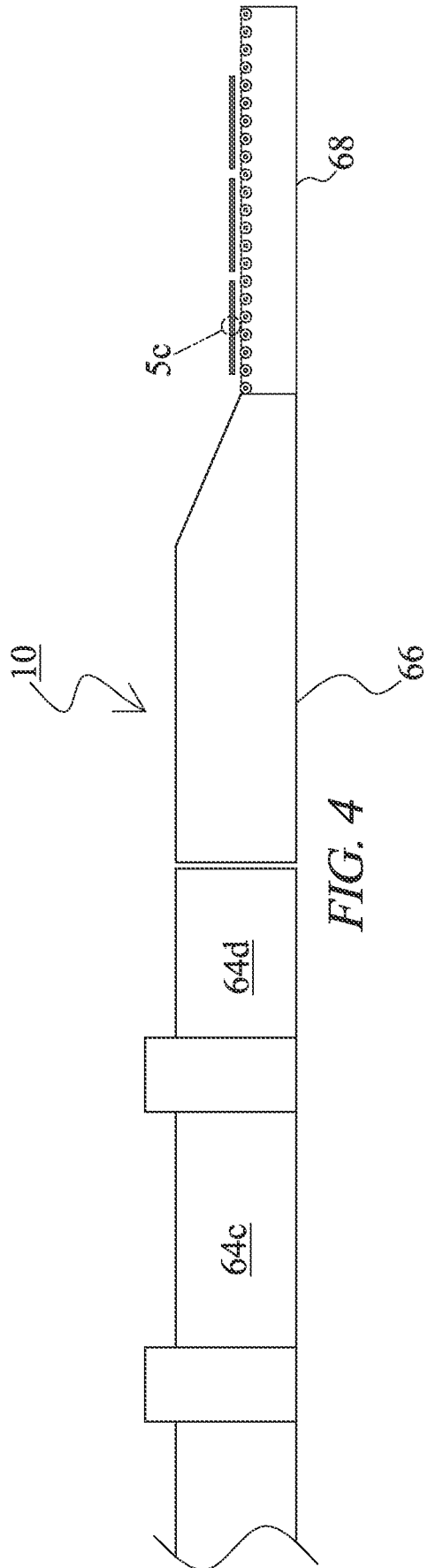
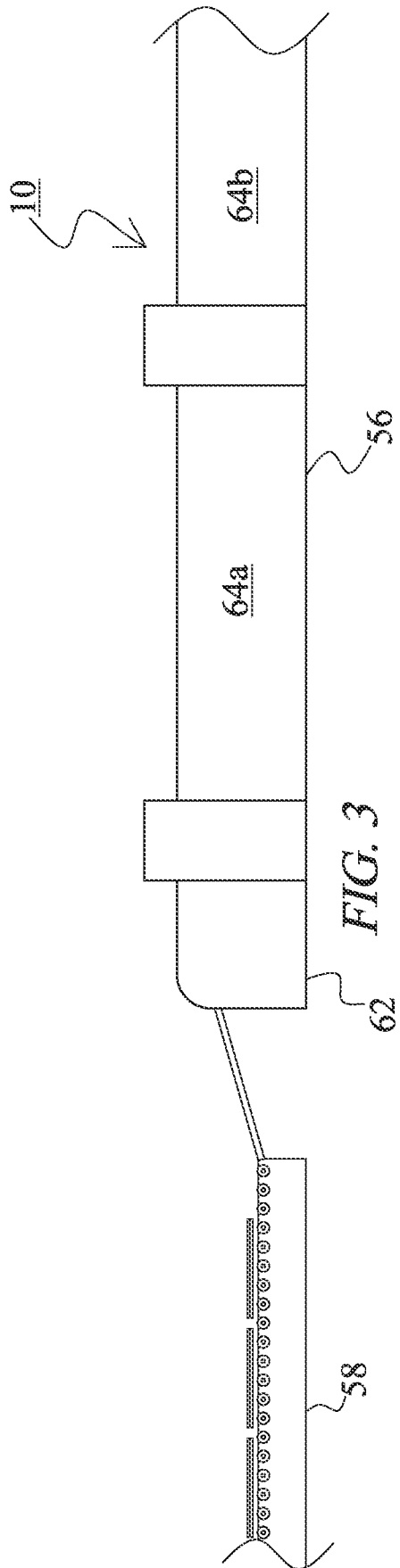

FIG. 2





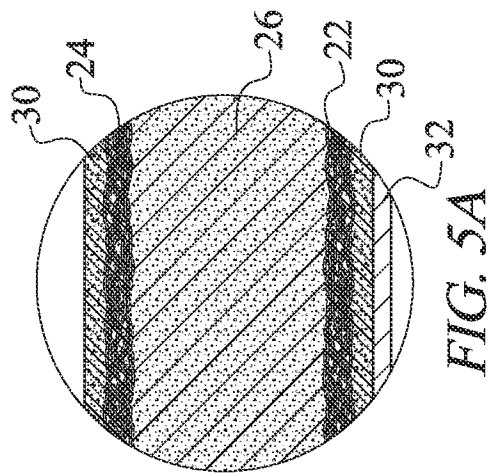

FIG. 5A

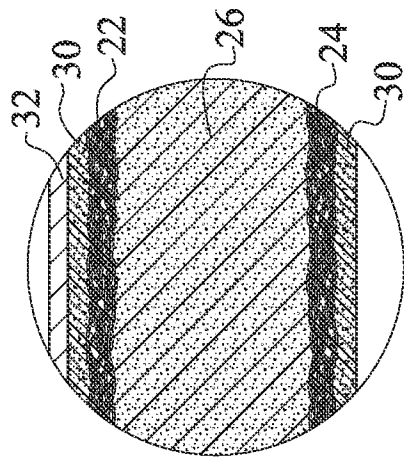

FIG. 5B

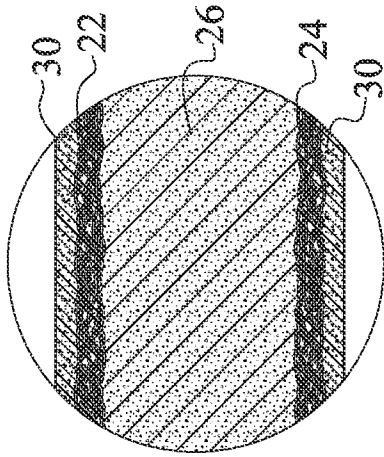

FIG. 5C

## INTERNATIONAL SEARCH REPORT

International application No.

PCT/US2011/038510

## A. CLASSIFICATION OF SUBJECT MATTER

IPC(8) - E04C 2/24 (2011.01)

USPC - 428/68

According to International Patent Classification (IPC) or to both national classification and IPC

## B. FIELDS SEARCHED

Minimum documentation searched (classification system followed by classification symbols)

IPC(8) - E04C 2/00, 24(2011.01)

USPC - 52/all subclasses; 414/all subclasses; 428/68, 294.1; 442/all subclasses

Documentation searched other than minimum documentation to the extent that such documents are included in the fields searched

Electronic data base consulted during the international search (name of data base and, where practicable, search terms used)

PatBase, Google Patents, Google

## C. DOCUMENTS CONSIDERED TO BE RELEVANT

Category*	Citation of document, with indication, where appropriate, of the relevant passages	Relevant to claim No.
Y	US 2005/0202742 A1 (SMITH et al) 15 September 2005 (15.09.2005) entire document	1-10
Y	Celvol® Polyvinyl Alcohol - Solution Preparation Guidelines. Guidelines [online], Sekisui Specialty Chemicals America, LLC < <a href="http://www.celvol.com/sekisui/home.htm">http://www.celvol.com/sekisui/home.htm</a> >. 2009-12-21 [retrieved on 2011-09-15]. Retrieved from the internet: <URL: <a href="http://www.celvol.com/sekisui/files/solution_preparation_guide_pvoh_1060.pdf">http://www.celvol.com/sekisui/files/solution_preparation_guide_pvoh_1060.pdf</a> >	1-10
Y	US 2002/0187296 A1 (HAUBER et al) 12 December 2002 (12.12.2002) entire document	1

 Further documents are listed in the continuation of Box C.

\* Special categories of cited documents:

"A" document defining the general state of the art which is not considered to be of particular relevance

"E" earlier application or patent but published on or after the international filing date

"L" document which may throw doubts on priority claim(s) or which is cited to establish the publication date of another citation or other special reason (as specified)

"O" document referring to an oral disclosure, use, exhibition or other means

"P" document published prior to the international filing date but later than the priority date claimed

"T" later document published after the international filing date or priority date and not in conflict with the application but cited to understand the principle or theory underlying the invention

"X" document of particular relevance; the claimed invention cannot be considered novel or cannot be considered to involve an inventive step when the document is taken alone

"Y" document of particular relevance; the claimed invention cannot be considered to involve an inventive step when the document is combined with one or more other such documents, such combination being obvious to a person skilled in the art

"&amp;" document member of the same patent family

Date of the actual completion of the international search

15 September 2011

Date of mailing of the international search report

**22 SEP 2011**

Name and mailing address of the ISA/US

Mail Stop PCT, Attn: ISA/US, Commissioner for Patents

P.O. Box 1450, Alexandria, Virginia 22313-1450

Facsimile No. 571-273-3201

Authorized officer:

Blaine R. Copenheaver

PCT Helpdesk: 571-272-4300

PCT OSP: 571-272-7774