

April 26, 1966

D. E. BLOXSOM
SKYLIGHT CONSTRUCTION

3,247,632

Filed April 17, 1963

2 Sheets-Sheet 1

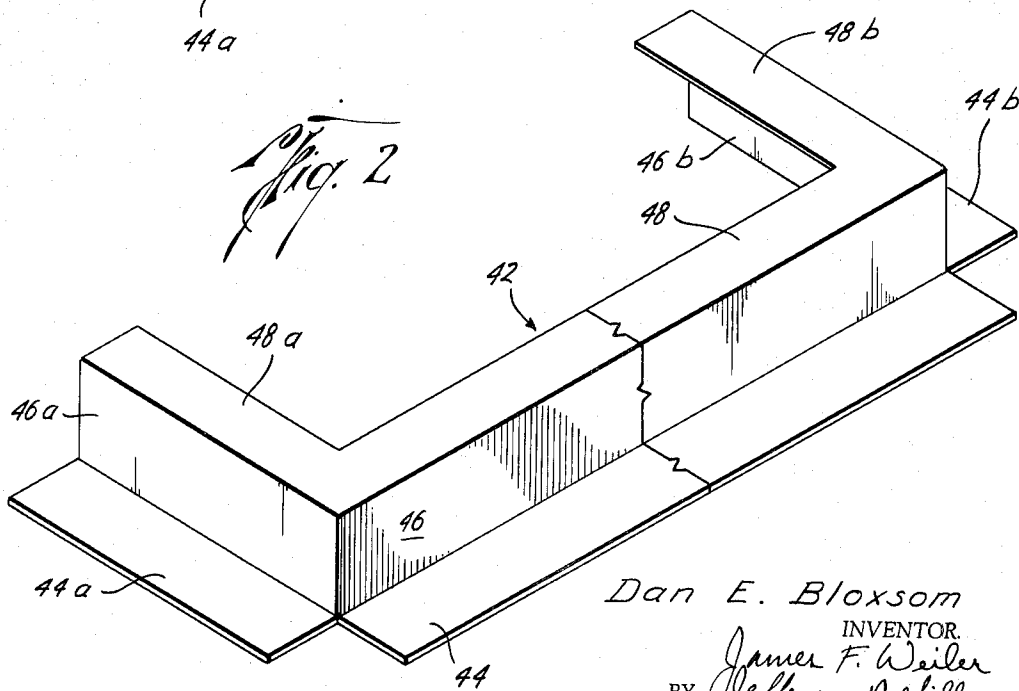
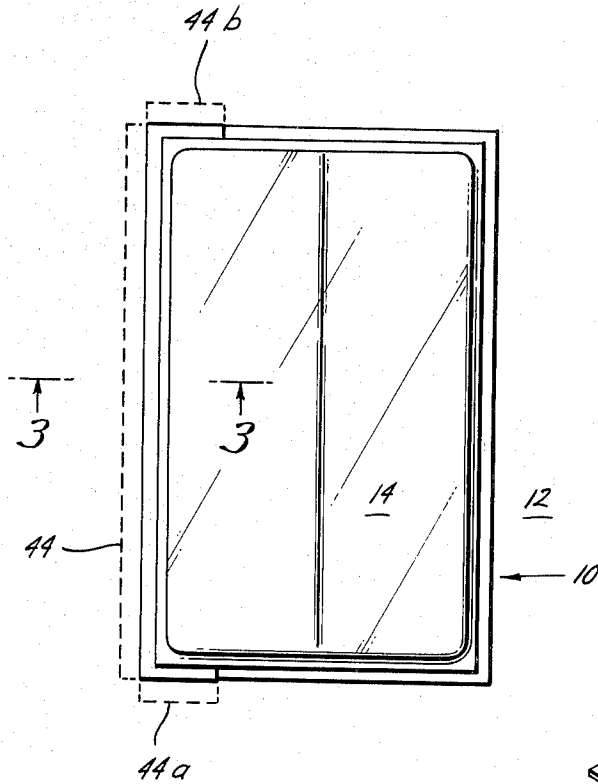

Dan E. Bloxsom
INVENTOR

BY *James F. Weiler*
Jefferson D. Miller
William A. Stout &
Paul R. Denton II
ATTORNEYS

April 26, 1966

D. E. BLOXSOM

3,247,632

SKYLIGHT CONSTRUCTION

Filed April 17, 1963

2 Sheets-Sheet 2

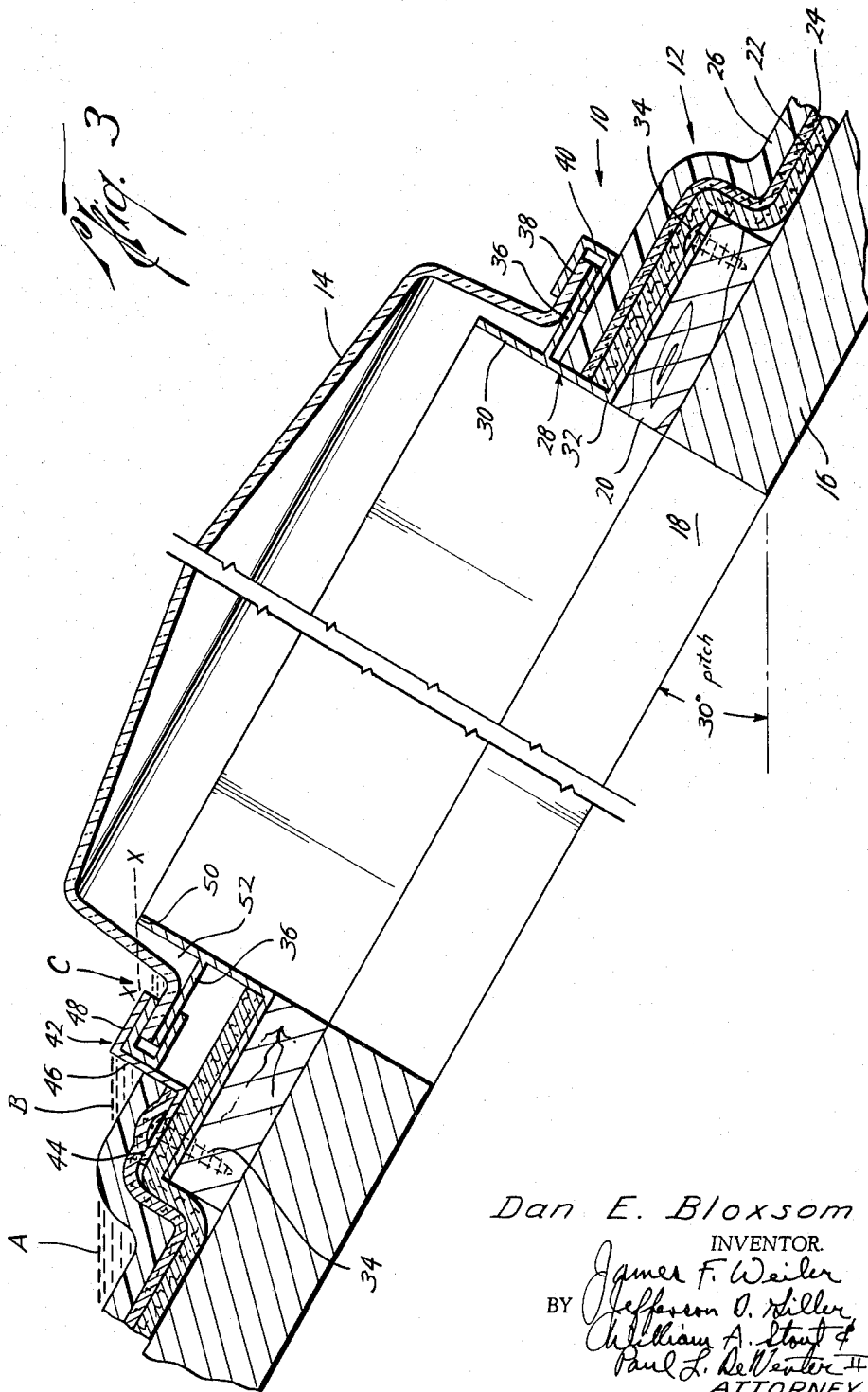

Dan E. Bloxsom
INVENTOR.

BY James F. Weiler
Jefferson O. Miller
William A. Stout &
Paul L. DeVenter, Jr.
ATTORNEYS

1

3,247,632

SKYLIGHT CONSTRUCTION

Dan E. Bixsom, 5615 Rice Ave., Houston, Tex.
 Filed Apr. 17, 1963, Ser. No. 273,698
 8 Claims. (Cl. 52—200)

This invention relates to improvements in skylight construction.

The use of skylight construction, such as plastic domes, has generally been limited to substantially flat or gently sloping roof structures. These skylight constructions have not been satisfactory for more sharply pitched roofs, for example a roof having a pitch of 30°, due to water flowing down the roof and into the skylight and leaking. There have been many skylight constructions proposed and made, but none is known which effectively prevents leaking on sharply pitched roofs, such as roofs having a pitch of 30° and more.

It would be highly advantageous to provide a skylight construction, that is one utilizing a plastic or other type dome, which will not leak even when used on sharply pitched roofs, such as roofs having a pitch in the range of 30° and more. The present invention is directed to such a skylight construction.

It is therefore an object of the present invention to provide a skylight construction which will not leak when placed on sharply pitched roofs.

Yet a further object of the present invention is the provision of a skylight construction which may be used on sharply pitched roofs of the order of 30° and more which are relatively simple and inexpensive to construct and install and which are leak proof in use.

Other and further objects, features and advantages of the present invention will appear from the following description of a presently-preferred embodiment thereof, given for the purpose of disclosure, and taken, in conjunction with the accompanying drawings, in which like reference numerals designate like parts throughout the several views, and where

FIGURE 1 is a plan view of a skylight construction according to the invention,

FIGURE 2 is an enlarged, perspective view of a gutter member illustrated in FIGURE 1, and

FIGURE 3 is a cross-sectional view taken along the line 3—3 of FIGURE 1.

Referring now to the drawings, and particularly to FIGURE 1, the skylight construction is generally indicated by the reference numeral 10 and is shown in place on the pitched roof 12. The skylight construction 10 includes the plastic bubble or dome 14 which covers the skylight opening 18 in the roof. The dome 14, of course, may be made of any suitable material which will withstand the weather conditions to be encountered and yet provide light into the skylight opening 18. Since any desired dome made of any suitable material may be used, no detailed description thereof is deemed necessary or given.

The details of the skylight construction 10 are best illustrated in FIGURE 3, to which reference is now made. In this illustration the roof is of the so-called "built up type" although it may be of any desired type, for example shingles and the like.

As illustrated, the built up roof 12 includes the roof decking 16 which is provided with the skylight opening 18. Disposed about the skylight opening 18 is a framing or curb member 20, which in the case of built up roofs of the type illustrated is placed on top of the decking 16 adjacent the opening 18.

A typical built up roof is illustrated which includes a first layer of fibrous insulating material, such as the felt paper 22, disposed on the decking 16 and over the curb member 20, ordinarily a second layer of such fibrous in-

2

ulating material 24 on top of the first layer 22 over which is placed a layer of tar or asphaltic material 26 into which is placed gravel, slag and the like, not shown. This is a typical built up roof construction; however, it will be understood that the skylight construction 10 may be applied to any type roof construction.

The skylight construction includes a structural or frame member 28, which includes what might be termed a retaining wall 30 which extends upwardly from the curb member 20 around the skylight opening 18 and forms a continuation thereof. The frame member 28 includes an outwardly extending base flange member 32 which seats on and is secured to the curb member 20, such as by the screws 34.

It is noted that the base member or flange 32 is disposed under the roof materials, here shown as the layers of felt paper 22 and 24, and the layer of tar or asphaltic material 26.

Disposed intermediate the ends of the retaining wall or member 30, and extending outwardly is the flange 36, which extends completely around the retaining wall 30, and which forms a seat against which the outer marginal ends 38 of the plastic skylight 14 are placed and tightly secured thereto by the generally U-shaped securing member 40, which is welded or otherwise secured together so that it completely surrounds the marginal ends 38 of the plastic skylight 14 and the underside of the seat 36 as shown. Thus, the skylight 14 is supported by and is securely held in place by means of the seat 36 and the retaining or securing member 40.

With the construction described and shown, and without any additional leakage preventing means, leakage would occur at the high side of the skylight construction when placed on a sharply pitched roof. In order to prevent this leakage from occurring, what might be termed an additional seal strip generally indicated by the reference numeral 42 is utilized adjacent the high side of the skylight construction which preferably extends downwardly along the sides of the skylight construction a short distance.

The seal strip 42 includes a generally flat, sheet-like base member 44, an upstanding wall member 46 and a flange member 48 extending inwardly from the upstanding member 46. In the event the side members are utilized, corresponding members 44a, 44b, 46a, 46b, 48a and 48b, are provided. Preferably, the members of the seal strip 42 are disposed at right angles to one another as shown, although any desired angle may be utilized.

Turning again to FIGURE 3, the seal strip 42 is shown in place and is here shown as secured by the same securing means, the screws 34, as the base flange 32 is secured to the curb 20. The base flange 44 of the auxiliary seal strip 42 is disposed under the second layer of felt paper 24 with the asphaltic material 26 disposed on top.

As best seen in FIGURE 1, the sides 44a and 44b extend a relatively short distance along the sides of the skylight construction 10 and, if desired, may be omitted.

Turning again to FIGURE 3, it is noted that on the upper side of the skylight construction 10 there are in effect three gutters formed as indicated by the letters A, B, and C. The first gutter A drains a considerable amount of water around the skylight construction. The second gutter B drains a still further amount of water around the skylight construction, and the gutters A and B, prevent any substantial accumulation of water in the third gutter C. In this connection it is noted that the top or high side 50 of the retaining wall 30 has a vertical height in a horizontal plane generally indicated by the dotted line X—X. Thus, no leakage will occur inside of the skylight construction and into the opening 18 unless the water rises to a vertical height above the

horizontal level indicated by the dotted line X—X. The gutter arrangement illustrated prevents the water from rising above this level since the upper end of the upstanding wall member 46 of the seal strip 42 extends to a vertical height in a horizontal plane above the top or high side 50 of the retaining wall 30 and, hence, prevents leakage.

The water in the gutters A, B and C flow around the skylight construction and down the roof. Also, any water which might seep into the space 52 between the retaining wall 28 above the intermediate flange or seat 36 and the skylight 14, flows around the retaining wall and out the lower side.

As previously mentioned, the side walls of the auxiliary seal strip 42 may be omitted with satisfactory results. Preferably, however, the side members are provided and extend a relatively short distance to insure against any possibilities of leakage at the upper part of the sides. If desired, the side wall may extend a substantial distance; however, it is essential that drainage be provided at the lower side of the skylight construction for draining any water which may get into the skylight construction as previously described.

The structural members of the skylight construction may be formed of any suitable material, such as various of the metals and the like, for example extruded aluminum as well as other materials which are strong enough and which are suitable for such construction purposes.

The skylight opening 18 may be of any shape, and may be for single or multiple skylights. In this event, the frame member 28 is suitably conformed to the shape, the seat 36 is suitably provided to support the skylight domes, and the auxiliary seal strip 42 is suitably shaped and disposed around a high side of the skylight opening.

In some roof construction, the curb 20 is not raised, for example in shingle roof construction, where it is flush with the structural roof members. The skylight construction of the present invention is secured to these curb members as previously described and provides a satisfactory leak-proof skylight construction on inclined roofs.

While the present invention is particularly useful on highly or sharply pitched roofs, for example, of the order of 30° or more, it is also useful on roofs of less pitch. It is only necessary that the vertical height of the auxiliary seal strip be above the height in a horizontal plane of the wall of the skylight to effectively drain away from it and thus avoid leaking.

The present invention, therefore, is well adapted and suited to attain the objects and ends and has the advantages and features mentioned as well as others inherent therein.

While only a presently-preferred embodiment of the invention is given for the purpose of disclosure, changes in details and arrangement of parts may be made which are within the spirit of the invention as defined by the scope of the appended claims.

What is claimed is:

1. A skylight construction mounted on a pitched roof provided with a skylight opening comprising,
 a skylight frame member having an outwardly-extending base flange secured to and seated on the pitched roof about the skylight opening,
 an upstanding wall extending from and substantially normal to the base flange and about the skylight opening,
 a peripheral flange extending outwardly from and intermediate the ends of the upstanding wall,
 a skylight extending over the upstanding wall and enclosing the skylight opening, the periphery of the skylight terminating in an outwardly-extending flange disposed against and seated on the peripheral flange,

means securing the outwardly-extending flange of the skylight to the peripheral flange, and
 a seal strip disposed on the pitched roof adjacent and extending along the length of the high side of the skylight frame member, said seal strip including an upstanding member extending upwardly from the pitched roof, the upper end of which extends to a vertical height in a horizontal plane above the upper end of the upstanding wall and a flange extending angularly from adjacent the upper end of the upstanding member and extending over the securing means.

2. The skylight construction of claim 1 in which the upstanding member and the flange of the seal strip extend at least a portion of the length of the sides of the skylight frame member from the high side.

3. A skylight construction mounted on a pitched roof provided with a skylight opening comprising,

a skylight frame member having an outwardly-extending base flange secured to and seated on the pitched roof about the skylight opening,

an upstanding wall extending from and substantially normal to the base flange and about the skylight opening,

a peripheral flange extending outwardly from and intermediate the ends of the upstanding wall,

a skylight extending over the upstanding wall and enclosing the skylight opening, the periphery of the skylight terminating in an outwardly-extending flange disposed against and seated on the peripheral flange,

means securing the outwardly-extending flange of the skylight to the peripheral flange, and

a seal strip disposed on the pitched roof at the high side of the skylight frame member, said seal strip including a base member extending along the length of the high side of the skylight frame and disposed on the pitched roof, a wall member extending angularly and upwardly from the base member to a vertical height in a horizontal plane above the upper end of the upstanding wall of the skylight frame member, and a flange extending angularly toward and over the securing means from and adjacent the upper end of the wall member and extending over the securing means.

4. The skylight construction of claim 3 in which the base member, the wall member and the flange of the seal strip extend at least a portion of the length of the sides of the skylight frame member from the high side.

5. A skylight construction mounted on a pitched roof provided with a skylight opening comprising,

a skylight frame member having an outwardly extending base flange secured to and seated on the pitched roof adjacent the skylight opening,

an upstanding wall extending from and substantially normal to the base flange and about the skylight opening,

a peripheral flange extending outwardly from and intermediate the ends of the upstanding wall and providing a seat,

a skylight extending over the upstanding wall enclosing the skylight opening, the periphery of the skylight terminating in an outwardly-extending flange disposed against and seated on the seat,

means securing the outwardly-extending flange of the skylight to the peripheral flange, said means comprising a generally U-shaped member, when viewed in vertical section, the legs of which are disposed over the top of the outwardly extending flange of the skylight, the sides of the outwardly extending flange of the skylight and the seat and under the seat and snugly secure the skylight to the seat, and

a seal strip disposed on the pitched roof extending along the length of the high side of the skylight frame member, said seal strip including an upstanding member

extending upwardly from the pitched roof, the upper end of which extends to a vertical height in a horizontal plane above the upper end of the upstanding wall, and a flange extending angularly toward and over the securing means from and adjacent the upper end of the upstanding member. 5

6. The skylight construction of claim 5 in which the upstanding member and the flange of the seal strip extend at least a portion of the length of the sides of the skylight frame member from the high side. 10

7. A skylight construction mounted on a pitched roof provided with a skylight opening comprising, 10
 a skylight frame member having an outwardly-extending base flange secured to and seated on the pitched roof adjacent the skylight opening,
 an upstanding wall extending upwardly from and substantially normal to the base flange about the skylight opening,
 a peripheral flange extending outwardly from and intermediate the ends of the upstanding wall and providing a seat, 20
 a skylight extending over the wall and enclosing the skylight opening, the periphery of the skylight terminating in an outwardly-extending flange disposed against and seating on the seat, 25
 means securing the outwardly-extending flange of the skylight to the seat, said means comprising a generally U-shaped member, when viewed in vertical section, the legs of which are disposed over the top of the outwardly extending flange of the skylight, the sides of the outwardly extending flange of the

skylight and the seat and under the seat and snugly secure the skylight to the seat, and
 a seal strip disposed on the pitched roof at the high side of the skylight frame, said seal strip including a base flange extending along the length of the high side of the skylight frame and disposed on the pitched roof, a wall member extending angularly and upwardly from the base flange to a vertical height in a horizontal plane about the upper end of the upstanding wall of the skylight frame member, and a flange extending angularly toward and over the securing means from and adjacent the upper end of the wall member.

8. The skylight construction of claim 7 in which the base flange, the wall member and the flange of the seal strip extend at least a portion of the length of the sides of the skylight frame member from the high side.

References Cited by the Examiner

UNITED STATES PATENTS

470,896	3/1892	Parrott	50—117	X
1,626,808	5/1927	Gibson	98—60	X
3,068,753	12/1962	Kirkpatrick	50—116	X
3,090,613	5/1963	Bechtold	50—52	

FOREIGN PATENTS

91,914	6/1958	Norway.
--------	--------	---------

CHARLES E. O'CONNELL, *Primary Examiner.*
 JACOB SHAPIRO, EARL J. WITMER, *Examiners.*