

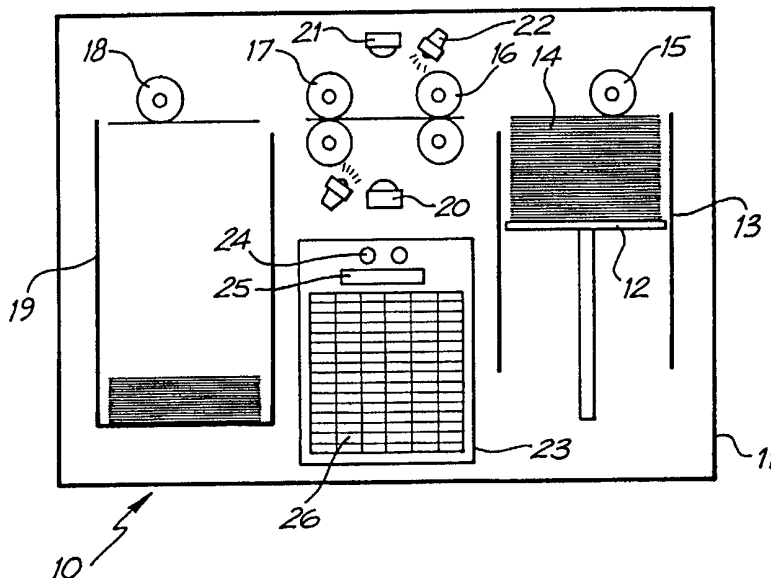

INTERNATIONAL APPLICATION PUBLISHED UNDER THE PATENT COOPERATION TREATY (PCT)

<p>(51) International Patent Classification <sup>7</sup> : <b>G06M 7/06, G06K 9/00, A63F 1/06, B07C 1/04</b></p>	<p><b>A1</b></p>	<p>(11) International Publication Number: <b>WO 00/51076</b> (43) International Publication Date: 31 August 2000 (31.08.00)</p>
<p>(21) International Application Number: PCT/AU00/00150 (22) International Filing Date: 24 February 2000 (24.02.00) (30) Priority Data: PP 8871 24 February 1999 (24.02.99) AU PQ 1444 6 July 1999 (06.07.99) AU PQ 4297 24 November 1999 (24.11.99) AU (71) Applicant (for all designated States except US): DOLPHIN ADVANCED TECHNOLOGIES PTY. LIMITED [AU/AU]; 600 Waterdale Road, Heidelberg West, Victoria 3081 (AU). (72) Inventor; and (75) Inventor/Applicant (for US only): PURTON, William, Westmore [AU/AU]; 99 Hotham Street, East Melbourne, Victoria 3002 (AU). (74) Agent: MISCHLEWSKI, Darryl, Burnett; 24 Christowel Street, P.O. Box 1254, Camberwell, VIC 3124 (AU).</p>		<p>(81) Designated States: AE, AL, AM, AT, AU, AZ, BA, BB, BG, BR, BY, CA, CH, CN, CR, CU, CZ, DE, DK, DM, EE, ES, FI, GB, GD, GE, GH, GM, HR, HU, ID, IL, IN, IS, JP, KE, KG, KP, KR, KZ, LC, LK, LR, LS, LT, LU, LV, MA, MD, MG, MK, MN, MW, MX, NO, NZ, PL, PT, RO, RU, SD, SE, SG, SI, SK, SL, TJ, TM, TR, TT, TZ, UA, UG, US, UZ, VN, YU, ZA, ZW, ARIPO patent (GH, GM, KE, LS, MW, SD, SL, SZ, TZ, UG, ZW), Eurasian patent (AM, AZ, BY, KG, KZ, MD, RU, TJ, TM), European patent (AT, BE, CH, CY, DE, DK, ES, FI, FR, GB, GR, IE, IT, LU, MC, NL, PT, SE), OAPI patent (BF, BJ, CF, CG, CI, CM, GA, GN, GW, ML, MR, NE, SN, TD, TG).</p> <p><b>Published</b> With international search report. Before the expiration of the time limit for amending the claims and to be republished in the event of the receipt of amendments.</p>

(54) Title: INSPECTION OF PLAYING CARDS



(57) Abstract

A card inspection device comprising: a loading area (13) adapted to receive one or more decks of playing cards, a drive or feed roller (15) to impinge on a card present in the loading area to urge the card one at a time through an exit of the loading area, a transport path (16, 17, 18 of fig.1) extending from the loading area to a card accumulation area (19 of fig.1) or a window on the loading area floor (154 of fig.6), a digital camera (20 of fig.1) located to sense the suit and value of the card either in the transport path or in the window of the loading area (153 of fig.6), a processor for governing the operation of the camera and the movement of card, and a printer for producing a record of the device's operation based on an output of the processor.

*FOR THE PURPOSES OF INFORMATION ONLY*

Codes used to identify States party to the PCT on the front pages of pamphlets publishing international applications under the PCT.

AL	Albania	ES	Spain	LS	Lesotho	SI	Slovenia
AM	Armenia	FI	Finland	LT	Lithuania	SK	Slovakia
AT	Austria	FR	France	LU	Luxembourg	SN	Senegal
AU	Australia	GA	Gabon	LV	Latvia	SZ	Swaziland
AZ	Azerbaijan	GB	United Kingdom	MC	Monaco	TD	Chad
BA	Bosnia and Herzegovina	GE	Georgia	MD	Republic of Moldova	TG	Togo
BB	Barbados	GH	Ghana	MG	Madagascar	TJ	Tajikistan
BE	Belgium	GN	Guinea	MK	The former Yugoslav Republic of Macedonia	TM	Turkmenistan
BF	Burkina Faso	GR	Greece	ML	Mali	TR	Turkey
BG	Bulgaria	HU	Hungary	MN	Mongolia	TT	Trinidad and Tobago
BJ	Benin	IE	Ireland	MR	Mauritania	UA	Ukraine
BR	Brazil	IL	Israel	MW	Malawi	UG	Uganda
BY	Belarus	IS	Iceland	MX	Mexico	US	United States of America
CA	Canada	IT	Italy	NE	Niger	UZ	Uzbekistan
CF	Central African Republic	JP	Japan	NL	Netherlands	VN	Viet Nam
CG	Congo	KE	Kenya	NO	Norway	YU	Yugoslavia
CH	Switzerland	KG	Kyrgyzstan	NZ	New Zealand	ZW	Zimbabwe
CI	Côte d'Ivoire	KP	Democratic People's Republic of Korea	PL	Poland		
CM	Cameroon	KR	Republic of Korea	PT	Portugal		
CN	China	KZ	Kazakstan	RO	Romania		
CU	Cuba	LC	Saint Lucia	RU	Russian Federation		
CZ	Czech Republic	LI	Liechtenstein	SD	Sudan		
DE	Germany	LK	Sri Lanka	SE	Sweden		
DK	Denmark	LR	Liberia	SG	Singapore		
EE	Estonia						

## INSPECTION OF PLAYING CARDS

### FIELD OF THE INVENTION

The invention pertains to playing cards and more particularly to a device  
5 and methods for inspecting playing cards at speeds higher than achieved with  
manual inspection. Methods and apparatus for sorting are also provided.

### BACKGROUND OF THE INVENTION

Playing cards are used in casinos worldwide. Many casinos have  
10 hundreds or thousands of decks of playing cards in use during the course of a  
business day. Different casino games require different decks, that is to say that  
not all games are played with a 52 card deck. Playing cards are currently  
inspected manually. A deck is inspected to insure that after use, the deck is  
complete and that no extra cards are present. This requires sorting the cards in  
15 each deck by suit and face value. Some games use multiple decks which  
further complicates the sorting process. Sorting after play is also performed so  
that integral decks may be re-sold.

### OBJECTS AND SUMMARY OF THE INVENTION

20 It is an object of the invention to provide an alternative to manual card  
inspection or sorting.

It is another object of the invention to provide a device and methods for  
inspecting, counting and reporting on the status of playing card decks.

It is also an object of the invention to provide a device which rapidly and  
25 conveniently produces a visual indication if a deck or group of decks is not  
integral.

Accordingly, the invention provides a card inspection device comprising: a loading area adapted to receive one or more decks of playing cards; a feed roller located adjacent the loading area and positioned to impinge of a card if a card were present in the loading area; the loading area having an exit through which cards are urged, one at a time, by the feed roller; a transport path extending from the loading area exit to a card accumulation area; the transport path further defined by two pairs of transport rollers, one roller of each pair above the transport path and one roller of each pair below the transport path; a digital camera located between the two pairs of transport rollers; a processor for governing the operation of the digital camera and rollers; and a printer for producing a record of the device's operation based on an output of the processor.

In another embodiment of the invention, a digital camera is mounted above either of the two platforms and captures imaging data by looking down.

In another embodiment of the invention, the digital camera is mounted between the two platforms.

In yet another embodiment of the invention, both platforms are operated, in synchrony, by a single electric motor.

In yet another embodiment of the invention, each platform is driven independently by an electric motor and the two electric motors are synchronised.

In another preferred embodiment, both platforms are driven by a single continuous belt, the belt being driven in forward and reverse directions by a single electric motor.

In one embodiment, an output of the reader is used to generate data for a printed report, the report produced by a printer located within a case which also contains the conveyor and optical reader.

5 In another embodiment, the circumference of each roller is at least as long as the path length of a card.

In yet another embodiment, illumination for the optical reader is provided by one or more blue LEDs.

In a further embodiment, all the rollers are driven by a single motor.

10 In a further preferred embodiment, the two or more pairs of rollers are driven by a single belt.

#### BRIEF DESCRIPTION OF THE DRAWING FIGURES

Figure 1 is a schematic diagram illustrating an example of a card inspection device according to the teachings of the present invention,

Figure 2 is a schematic elevation of an embodiment of a card inspection device according to the teachings of the present invention,

Figure 3 is a third embodiment of a card inspection device,

20 Figures 4 and 5 are schematic illustrations of alternate embodiments of a card inspection device according to the teachings of the invention,

Figure 6 is a schematic side elevation of a transport mechanism including camera placements for a card inspection device,

25 Figure 7 is a cross section of a card inspection device,

Figure 8 is a cross sectional side elevation of a card inspection device,

Figure 9 is another cross sectional side elevation of a card inspection device,

Figure 10 is a cross sectional top plan view of a card inspection device,

5 Figure 11 illustrates front and cross sectional side views of a card sensor,

Figures 12 and 13 are schematic cross sections of a card inspection device featuring a single drive roller,

10 Figure 14 is a schematic illustration of a card inspection device with collation features according to the teachings of the present invention,

Figure 15 is a schematic side elevation of a device incorporating an arrangement of tool sensors and baffles,

15 Figure 16 is a cross sectional elevation of a further embodiment including drive roller cleansing brush and removable accumulation container,

Figure 17 is a top view of the device depicted in Fig. 16,

Figure 18 is a left side elevation in cross section depicting the device shown in Fig. 16,

20 Figure 19 is a right side elevation which has been cross sectioned to illustrate the interior of the device depicted in Fig. 16.

#### BEST MODE AND OTHER EMBODIMENTS OF THE INVENTION

As shown in Figure 1, a card inspection device 10 of the present invention comprises a secure cabinet 11 which affords the user easy access to a card loading area 13 and a card accumulation area 19. The card loading area incorporates a moving platform or elevator 12. Cards 14 are placed on the  
25 loading platform or area 12 which is capable of lifting the one or more decks into engagement with a feed roller 15. The feed roller 15 feeds individual cards

between the first of a pair of transport rollers 16. Cards are passed between the first pair of transport rollers 16 to a second pair of transport rollers 17. An optional take-up roller 18 assists the cards into the accumulation area 19.

5           Below the gap between the first and second transport rollers there is located an optical scanning device. The scanning device 20 reads the card passing through the roller pairs and transmits the scan information to a computer or other signal processing device which identifies the value and suit of the card and compiles a tally of all cards read. The optical scanner may also  
10 be located above the gap 21 if the cards are face on the platform 12. In the alternative, optical scanners can be positioned both above and below the gap so that both sides of a card may be read or so that inverted cards may be detected and identified. Preferably a low temperature source of light 22 is located so as to illuminate the area of the card that is being scanned.

15           The computer or signal processor compiles the scan data and reports and records the result of the scans of all of the cards in the one or more decks. Preferably, the report is displayed on a graphic indicator 23. The report data or any portion of it may also be provided as the output of a RS232 port or other data port. The indicator 23 may be mounted directly on the cabinet 11. The  
20 indicator may include, for example, a red warning light 24 to show when an irregularity has been detected by the computer or signal processor. An adjacent green light would be indicative of a successful scan. In addition another display 25 could be used to reveal the exact card count. Another display 26 could be used to display exactly how many of each card were  
25 detected. For example a display matrix 26 could show all possible card values (i.e. A, K, Q,...4,3,2...Joker...blank) in a first column and all possible suits in a first row. By reading the numerical value in the intersection of a row and a

column, one can determine the quantity of each card in the deck or decks scanned. For example in an eight deck scan, one would expect that the display 26 would show in the intersection of the K(ing) row and the Spade column, the value 8.

5           Figure 2 illustrates, schematically, that the card accumulation area 19 may also be supplied with a moving accumulation platform 20. A means 21 of synchronising the two platforms 19 and 20 may also be provided. The means for synchronising 21 may be mechanical (pulleys, cables, toothed belts etc.) or electromechanical using servo motors or sensors etc. In this way the rising of  
10 the loading platform 12 may be synchronized with the falling of the accumulation platform 20.

          As shown in Figure 3, the cards 32 to be scanned may also be loaded from above, rather than from below. In this illustration, the cards are loaded from above into a bounded loading area 30. Cards are fed into the transport  
15 rollers by a feed roller 31 located below the cards 32. A weight 33 may be placed on the cards 32 to facilitate contact with the feed roller 31.

          As shown in Fig. 4, a further embodiment of a card inspection device  
20 110 comprises two card platforms 111, 112. Cards are placed face up, for example, on the first platform 111. An electric motor 113, for example a DC stepping motor is mechanically coupled to the first platform 111. When the appropriate commands are provided to the electric motor 113, the platform 111 goes up (as suggested by the arrow 114) so that a stack of playing cards 115 is urged into contact with a drive roller 116. In this example the face up cards in the feed stack 115 are individually imaged by a downward looking digital  
25 camera 117. A mirror may be employed so that the camera may read the face up cards from other orientations. The imaging information is provided to a microprocessor or digital signal processor 118. The output 119 of the



microprocessor 118 is used to drive any number of devices including for example a visual display, alarm devices or a printer (the various output devices being designated together as item 120).

5 The drive roller 116 ejects the cards from the first stack 115 into a second or output stack 121. So that the output stack forms in an orderly fashion, the second platform 112 descends 122 at the same rate as or at least in synchrony with the first stack. The motion of the second platform 112 and second stack 121 may be governed by the same electric motor 113 that drives the first platform 111. In the alternative, the motion of the second platform 112  
10 may be determined by an optional second electric motor 123 which is synchronised with the first motor 113 so that the stacks move at the same rate but in opposite directions.

In another embodiment of the invention, the downward looking digital camera 125 (or mirror arrangement) is placed above the second stack, looking  
15 down at it to image cards only after they have been loaded into the second stack 121. In any of the embodiments discussed here, a digital camera may image by looking at a mirror aimed at the target area of a card rather than at the target area directly. The use of a mirror folds the image path and can make it more compact.

20 So that the device may be loaded from either platform 111, 112 an additional and optional second drive roller 126 may be provided above the second platform 112. When cards are being fed by the first drive roller 116 from the first stack 115, the second drive roller 126 is raised 127 so that it does not interfere with the passage of playing cards from the first stack to the  
25 second. When the second drive roller 126 is used to feed cards onto the first platform 111, the first drive roller 116 must similarly be elevated to avoid interfering with the passage of cards onto the first platform 111.

As shown in Fig. 5, a single continuous belt 130 may be used to drive both card platforms 131, 132 in synchrony and with a single electric motor 133 (for example a DC stepping motor). Where the device 110 is only intended to feed cards from the first platform 131, to the second platform 132 only a single drive roller 134 is required. In this case, the first platform 131 is elevated by the continuous belt 130 so that the first stack 135 is brought into contact with the drive roller 134. The drive roller 134 transports cards to the second platform 132. The digital camera 136 may be located between the two platforms 131, 132 (either above or below) or it may be located directly above either platform as explained with reference to Fig. 4. Optional pairs of pinch rollers 140 may be provided between the two platforms 131, 132 to assist in the transport of cards from one platform to the other. Together, the drive roller 134 and the pinch rollers 140 define a transport path for the cards.

So that the device 110 of Fig. 5 may be loaded from either platform 131, 132 a second and optional drive roller 141 may be provided above the second stack 132. As mentioned with reference to Fig. 4, the second drive roller 141 must be elevated 142 when cards are being fed from the first platform 131. When feeding from the second platform 132, the direction of motion of the pinch rollers 140 must be reversed. Similarly, the direction of the belt 130 must also be reversed so that the first platform 131 is lowered as the second platform 132 is raised.

As shown in Fig. 6, a card stack 150 may be supported by a platform 151 through which a drive roller 152 extends. This allows cards to be fed from the bottom of the stack 150. In this embodiment, the cards are placed face down. So that each card may be read by an upward looking digital camera 153, the platform 151 is provided with a window or opening 154. In the alternative, the cards may be read between stacks 150, 155, by a digital

camera 156 mounted above (with the cards face up) or below the pinch rollers (with the cards face down) 157 which facilitate card transport between the two stacks 150, 155.

As shown in Figures 7-10, another embodiment of a card auditing machine 210 comprises a case 211. Within the case, an input or loading bin 212 is adapted to receive one or more decks of cards 213. The cards are loaded face up. A door 214 to the loading bin is hinged 215 along a lower edge. A free sliding weight 205 extends into the loading bin and when released, impinges on the cards 213 and urges them downward. A free weight 10 may also be used. The base of the loading bin is defined by a platen 217 having a rectangular opening 216. The cards 213 rest on the platen 217. The first roller 218 is formed as a cam, that is, a cylinder from which a flat spot along its entire length has been removed, for example, by abrasion. The roller rotates at a fixed speed and when it is in contact with a card, imparts a linear motion to the card. The flat spot on the roller does not contact the cards and therefore defines a gap between successive cards which are being urged by the roller 218 into the card path.

A card from the bottom of the stack (or the last one) is propelled by the first roller toward and into engagement with a first pair of rollers. The first pair 20 of rollers 219, 220 pinch together lightly (but need not contact) and rotate in synchrony. The first pair 219, 220 receives the card (preferably still in contact with the first roller) and advances the card toward and into engagement with the second pair of rollers 221, 222. Because the distance between the pairs of rollers is equal to or less than the length of the card in the direction of the path, positive control of the card is maintained until the card is ejected from the 25 second roller pair 221, 222 into the output bin 223.

In alternate embodiments, the platen 217 optionally extends along the card path past the loading bin 212 so as to support the card, at least as far as the second roller pair 221, 222 (or as required). Openings 216 in the platen 217 allow both rollers in each pair to be positioned in the card path. Additional  
5 guide rails 280 adjacent the card path may be used to assist the transport.

As seen in Figure 7, a single motor 224 drives all five rollers 218 – 222. A single belt 225 drives the two pairs of rollers 219 – 222. A second belt 226 goes around the sheaves associated with one roller 219 of the first pair and the first roller 218.

10 A card presence sensor 230 (see Figure 11) is located between the roller pairs 219 – 222. The sensor uses, for example, optical means to detect the presence and position of a card and may act as a trigger to the camera control software so that an image will be captured at the appropriate point in time. The sensor may also be used to detect machine malfunctions. By  
15 detecting that the frequency of cards passing it varies from the expected rate, the sensor output may be used to report malfunction or failure or to cause the machine's operation to be ceased.

As there is no appreciable light within the case 211, an LED illuminator 231 is also located between the roller pairs. The illuminator comprises a single  
20 or multiple LEDs. The LED illuminator provides an output in the blue range which is optimised to maximize the contrast in the monochrome image made by the red suits. In this (monochrome) example, six individual blue LEDs are assembled into a bank to provide adequate and even illumination. Thus, in this monochrome example red and black are practically indistinguishable, but the  
25 enhanced performance in the red range is traded for colour (red-black) detection, which is of little use. The camera 232 reads the face of the cards and using on board image processing, provides a data output which includes

the suit and value portion of the face of the card. This is done by the software and without recourse to the colour of the suit, by examining parameters of the camera image such as image "centre of gravity", perimeter length, number and type of edge and other characteristics of the suit and value as they are  
5 displayed on the cards. The data output can be used to determine the identity of a card or to "train" verification or recognition software for future use. In the alternative, full colour imaging (digital or analogue) may be employed.

A keypad 235 on the front of the machine is used to input data about the identity of the user, the location or table number, the game the cards are used  
10 for, the number of packs to be checked and configuration information such as time and date etc. The user may be lead through the data input routine by prompts provided on a display screen 240, in this example, located near the keypad. The keypad input and camera output are used to generate a file which can be printed by the printer 234 or displayed on the front panel display 240.  
15 The keypad may also be used for secure access and other control functions related to the use of the device.

Some playing cards carry a significant static charge and are difficult to separate. Accordingly, the device may incorporate a means for removing or dissipating the static charge. One method of dissipating the static charge is to  
20 line the input bin with a material such as polyethylene impregnated with carbon black 281 (see Figures 7 and 10). Conductive brushes which contact both surfaces of the card may be used. Such brushes should be placed, for example, after each or any exit side of a pair of transport roller or the exit of the device.

25 In keeping with the teachings provided above, simplified mechanical transport may be achieved, as shown in Figures 12 and 13, by providing a window or transparent region 260 in the bottom surface or floor 261 of the input

bin 262. This allows cards (now face down) to be read from within the bin 262. Cards are removed to an output or collection bin 263 by a roller 264. The roller may be driven directly or with a motor and belt system 265.

5 If the camera 270 will fit directly below the window 260 it may be located there without the need for mirrors or prisms. If more room is required, the camera or imager 270 may be offset with the use of mirrors or prisms 271, 272. Vertical and horizontal camera placements are depicted in Figures 12 and 13. Lighting for such arrangements may be provided by locating the LED or other illumination source 275 so that it shines in the mirror 271 but is not directly in  
10 the optical path of the camera. As shown in Figure 12, upward shining LEDs may be located near the lens 276 of the camera without blocking the view of the camera. As shown in Figure 13, additional and direct illumination may be provided by locating LEDs near the window 260.

15 As shown in Figure 14, a card inspection device 300 may be equipped with a collator 301 rather than a single collection stack. One purpose of a collator 301 is to allow the unsorted cards in the input stack 302 to be reassembled into useable and potential vendible decks. In this example, the output of the digital camera 303 is supplied to a microprocessor 304. The microprocessor 304 performs the functions which have been described above  
20 and in addition co-ordinates the timing of the main drive wheel 305 and intermediary drive or transport rollers 306, 307 with the movements of the collator 301. The collator 301 features a plurality of output trays 308 each of which are capable of receiving individual cards and each of which can accommodate a full deck. The trays 308 move, for example, up and down  
25 owing to the operation of a transport mechanism 309 which receives instructions from the microprocessor 304. Individual cards 310 are first read by the digital camera 303 and microprocessor 304 before being introduced into a

tray 308. The microprocessor 304 tallies the value and suit of each card in a tray 308. When it is determined that the insertion of a card 310 would represent a duplicate within a given tray 308, the microprocessor 304 instructs the transport mechanism 309 to present a new tray 308 to the exiting card 310.

5 In this way, no tray 308 can contain duplicate cards. The initial input from the machine operator instructs the microprocessor 304 as to how many decks will be input into the device. This data is used to then instruct the collator 301 as to how many trays 308 to present to the cards exiting the device. The transport mechanism 309 may consist of a belt drive or a direct drive

10 mechanism featuring a DC stepping motor and controller which is responsive to the command signals sent by the microprocessor 304 or peripheral device under the control of the microprocessor 304. Each tray 308 features an exit opening 310 through which cards may be removed. Ideally, the collation process will produce an intact and integral deck in each operational tray 308. It

15 will be appreciated that a collator 301 may be used as an accessory to or as a replacement for the output stack in any one of the embodiments that have been disclosed.

As shown in Figure 15, some embodiments of the invention utilise other sensors in addition to a digital camera. In addition to the digital imaging

20 camera and its light source which have been discussed above, a device according to the teachings of the present invention may also incorporate a line scanner, a photodiode or a plurality of different sensors, each of which responds to a different type of light source. Casino players are known to utilise pinholes, score marks, scratches, marking inks and invisible chemicals which

25 may make microscopic surface changes on the cards for the purpose of cheating and defrauding casinos. As mentioned above, the detection of card suit and value may be accomplished with a blue LED. The detection of

different forms of tampering requires the utilisation of white light, polarised light, UV, IR (infra-red) and other coloured light. In addition, the card's fluorescence and absorption properties on both surfaces may need to be sensed. It has been found that the orientation of a light source may need to be changed during the examination of a card. different lighting conditions and lighting orientations may therefore be required to detect deliberate or incidental handling damage which may act as a cue for card counters and cheats. In order to enable the device to contend with many different forms of detection and light sources, the card transport path must be subdivided.

Figure 15 illustrates how a card transport path 400 may be subdivided by locating baffles 401 above or below the roller pairs 402 in order to create distinct zones 403. Each zone 403 may have a particular form of detector, polarimeter, diode or line scanner as well as a particular light source or lighting method. By locating sensors both above and below the transport path, both sides of the card may be examined simultaneously. This provides the opportunity to detect suit and value of an inverted card as well as increasing the sophistication with which tampering may be detected.

Polarised light may be used to detect certain forms of tampering. In such a case, the polarity of the light source may be rotated during the detection process. Similarly, an unpolarised source may be moved during the detection process to create a moving shadow.

One or more light sources 404 may be movable or set to illuminate off-axis so that certain forms of scratches and pinholes may be more easily detected by their shadow or reflectance. It is contemplated that both colour and monochrome imaging methods may provide useful information about the condition of the cards. Similarly both digital and analogue sensing methods are seen to have independent utility and functionality with regard to both suit



and value detection as well as the detection of faults, wear and tampering. It should be noted that the compartmentalisation of the card transport path into distinct lighting and sensing zones may be applied to any one of the embodiments disclosed within this document and suggested in the  
5 accompanying Figures 1-14.

As shown in Fig. 16, each playing card may be cleaned as it enters the transport path 500 by positioning a rotating brush 501 so that it impinges on, in this example, the drive roller 510. The drive roller transfers dirt etc. from the cards to the brush 501. As best seen in Figure 18, this brush is generally  
10 cylindrical and preferably includes radially oriented camel hair bristles. Camel hair bristles resist the effect of moisture and are capable of removing grease, talc and dirt from the cards.

Figure 16 also illustrates that the card accumulation area 503 may take the form of an elevator. The elevator is driven by a motor such as a DC  
15 stepping motor which is co-ordinated with the action of the drive and transport rollers. The elevator is adapted to removably receive a container 504. The container 504 may be in the form of a transparent box which temporarily and mechanically interconnects with the elevator mechanism. The elevator and therefore the box 504 begin at an upper 505 position and gradually descend as  
20 more cards are placed on top of the accumulating output stack 506. When the box 504 is full or when the inspection operation is complete, the box 504 is removed. Prior to closing or sealing the box with its lid (not shown), the printed report which is output by the device's printer is inserted in the box 504. The cleaning brush 501 may be driven by or synchronized with a synchronisation  
25 belt 511 which is also connected to the drive roller 510.

As shown in Figs. 16 and 19, the device may also be provided with an integral handle 520 for convenience of handling. In some embodiments, the

back of the cover 521 may be hinged at a lower extremity 522 so that the transport path may be conveniently accessed if required for the purpose of maintenance or the clearing of the transport path 500.

5 While the invention has been described with reference to particular details of construction, these should be taken as illustrative and useful in various combination and not as limitations to the scope or spirit of the invention.

CLAIMS

1. A card inspection device comprising:
  - a loading area adapted to receive one or more decks of playing cards;
  - a drive roller located adjacent the loading area and positioned to impinge of a card if a card were present in the loading area;
  - the loading area having an exit through which cards are urged, one at a time, by the feed roller;
  - a transport path extending from the loading area exit to a card accumulation area;
  - the transport path further defined by two pairs of transport rollers, one roller of each pair above the transport path and one roller of each pair below the transport path;
  - a camera located between the two pairs of transport rollers;
  - a processor for governing the operation of the digital camera and rollers; and
  - a printer for producing a record of the device's operation based on an output of the processor.
  
2. The device of claim 1, wherein:
  - a second camera is located between the two pairs of transport rollers, a sensor located on the opposite side of the transport path as the other camera;
  - the camera used to sense the suit and value of a card and the sensor used to sense the colour or other attribute of the back of the card.
  
3. The device of claim 1, wherein:

a portion of the transport path is illuminated by one or more blue LEDs.

4. The device of claim 1, wherein:  
the device is enclosed in a secure case, the case having on its exterior, a keypad for supplying instructions and user data to the processor.
5. The device of claim 1, wherein:  
the card accumulation area comprises a bin having a card entry toward an upper extremity.
6. The device of claim 1, wherein:  
the card accumulation area comprises a movable platform, the motion of the platform being coordinated with a rate of entry of cards into the area.
7. The device of claim 1, wherein:  
the accumulation area also serves as a second loading area;  
the second loading area having a second feed roller;  
the second feed roller adapted to impinge on a card and insert it into the transport path;  
the transport rollers being bi-directional so that card may be loaded into either the loading area or the second loading area.
8. The device of claim 1, wherein:  
the various rollers are driven by a single motor.

9. The device of claim 8, wherein:  
the various rollers are driven by a single belt.
10. The device of claim 1, wherein:  
all rollers are of the same diameter.
11. The device of claim 1, wherein:  
a distance between adjacent pairs of transport rollers is equal to or less than the length of a card which the device is adapted to inspect.
12. The device of claim 1, wherein:  
a trigger to the processor is provided in the transport path, the trigger adapted to sense the presence of a card and transmit a signal to the processor to facilitate the capture of an image from the camera.
13. The device of claim 1, wherein:  
the card accumulation area comprises a collator, the collator having a plurality of bins, each positionable into and out of the transport path according to instruction from the processor.
14. A card inspection device comprising:  
a loading area adapted to receive two or more decks of playing cards;  
a feed roller located adjacent the loading area and positioned to impinge on a card if a card were present in the loading area;  
the loading area having an exit through which cards are urged, one at a time, by the feed roller;

the loading area having a floor, the floor having a window through which a card may be imaged;

a card accumulation area located immediately adjacent the exit;

a digital camera having an optical path which includes the window;

a processor for governing the operation of the digital camera and feed roller; and

a printer for producing a record of the device's operation based on an output of the processor.

15. The device of claim 15, wherein:

the window is illuminated by one or more blue LEDs.

16. The device of claim 14, wherein:

the device is enclosed in a secure case, the case having on its exterior, a keypad for supplying instructions and user data to the processor.

17. The device of claim 14, wherein:

the card accumulation area comprises a bin having a card entry toward an upper extremity.

18. The device of claim 17, wherein:

the card accumulation area comprises a movable platform, the motion of the platform being coordinated with a rate of entry of cards into the area.

19. The device of claim 14, wherein:

a trigger to the processor is provided in the transport path, the trigger adapted to sense the presence of a card and transmit a signal to the processor to facilitate the capture of an image from the camera.

20. The device of claim 14, wherein:

the card accumulation area comprises a collator, the collator having a plurality of bins, each positionable into and out of the transport path according to instruction from the processor.

21. The device of claim 1, wherein:

the transport path comprises two or more zones separated by baffles, at least one sensing device or camera and a light source located in each zone.

22. The device of claim 21, wherein:

one of the sensing devices is a line scanner, colour sensor, photo diode, UV sensor, IR sensor or polarimeter.

23. The device of claim 21, wherein:

the baffles are located above or below a roller pair in the transport path and the baffles are light seals.

24. The device of claim 1, further comprising:

a rotating cleaning brush which impinges on the drive roller.

25. The device of claim 21, wherein:

the accumulation area further comprises a removable container for receiving the cards.



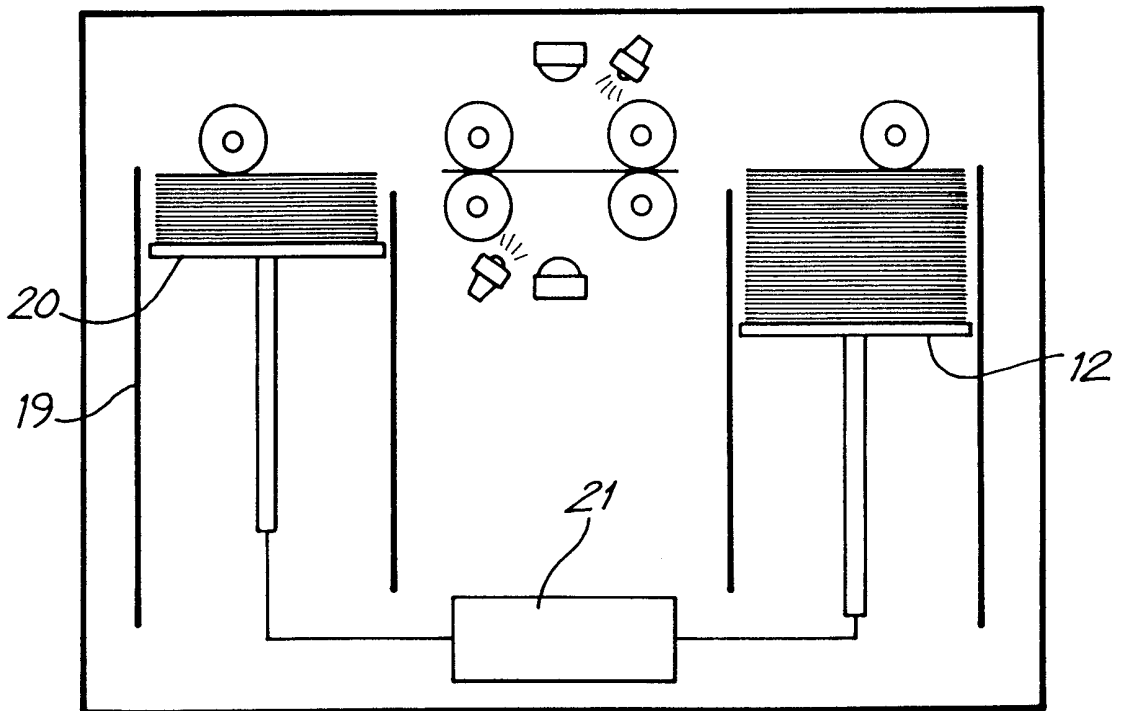
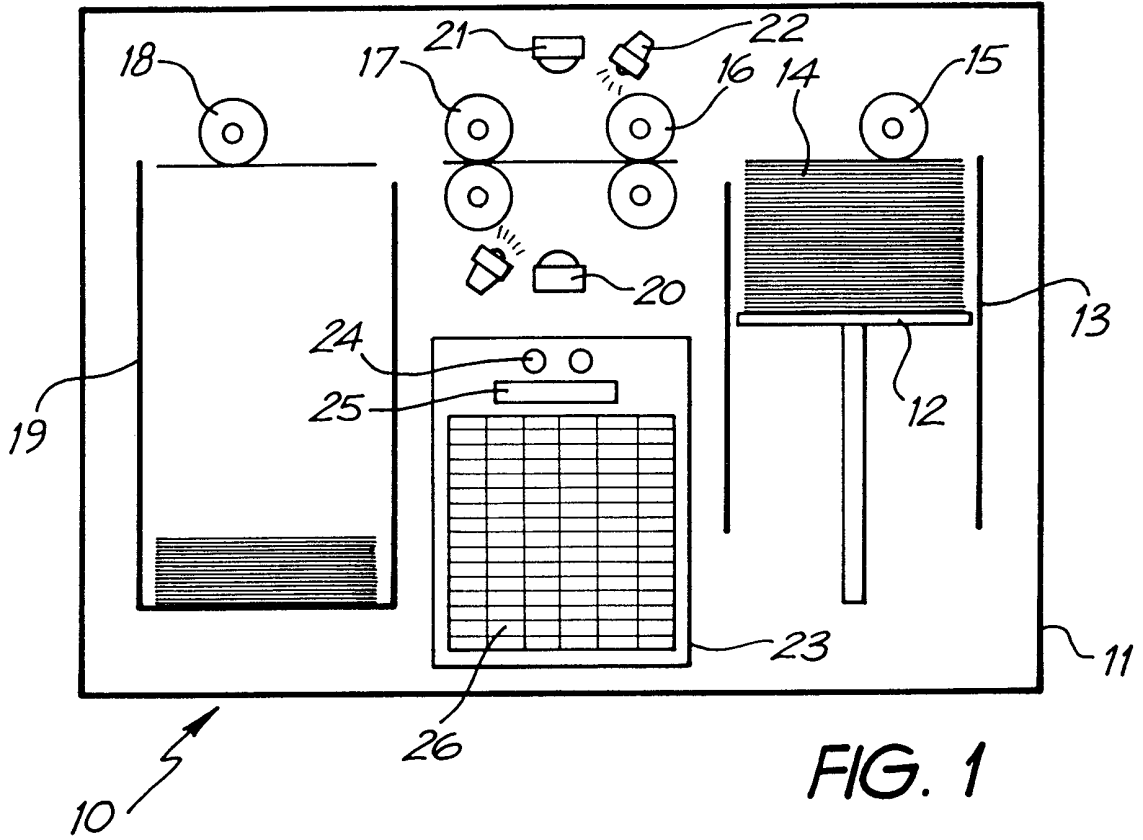

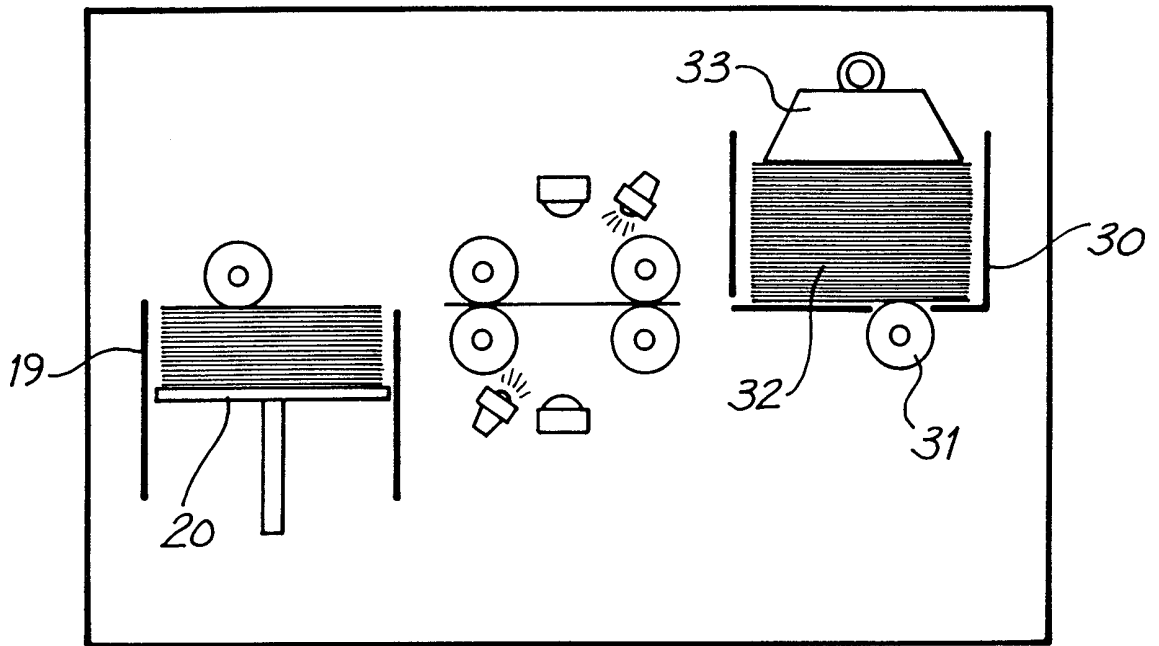

FIG. 3

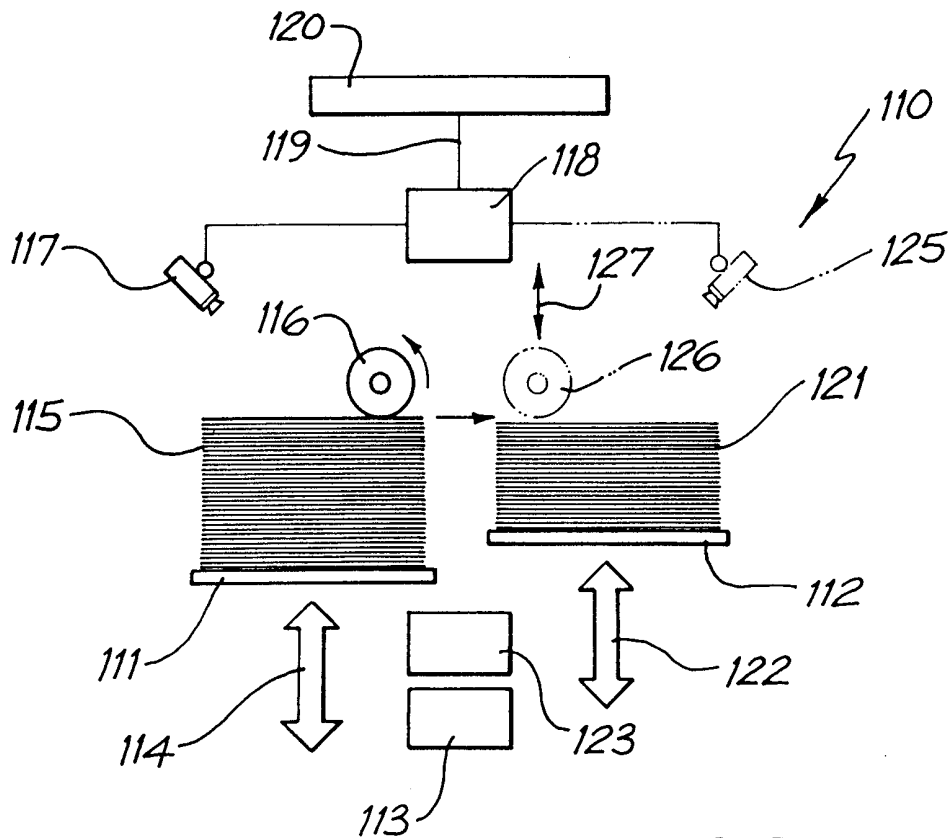

FIG. 4

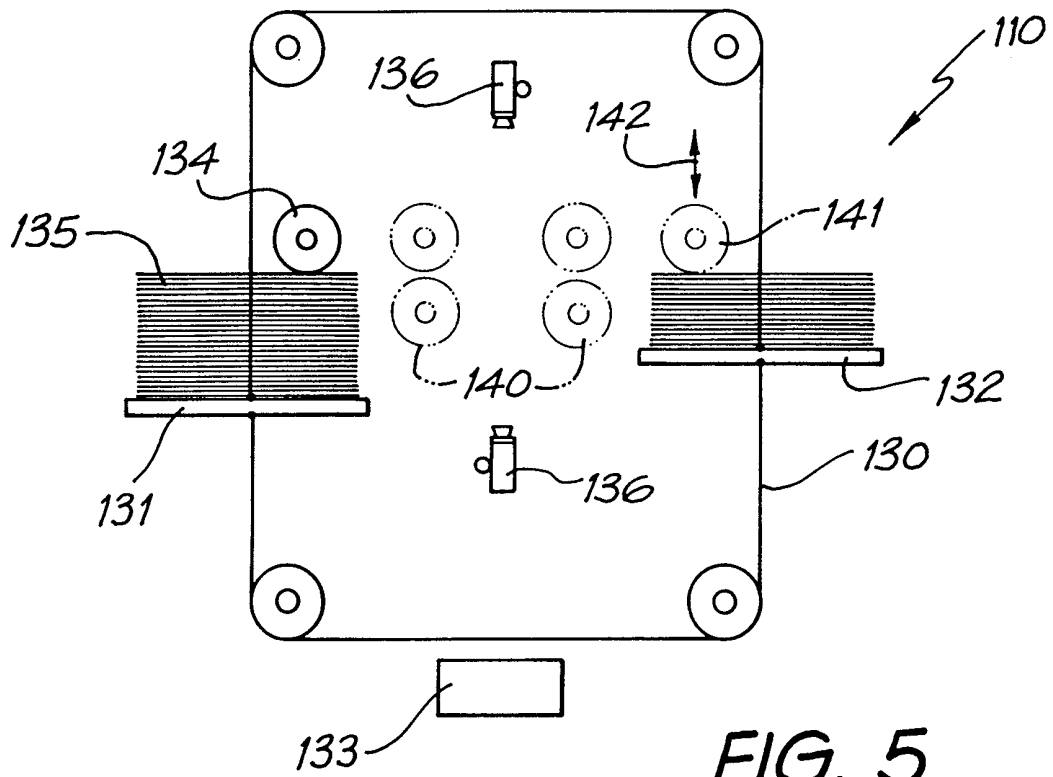

FIG. 5

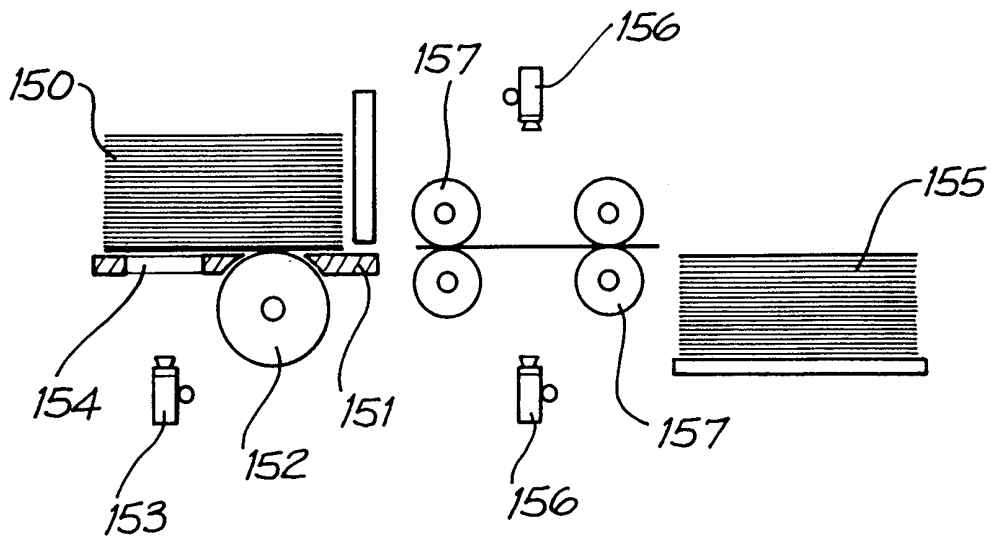

FIG. 6

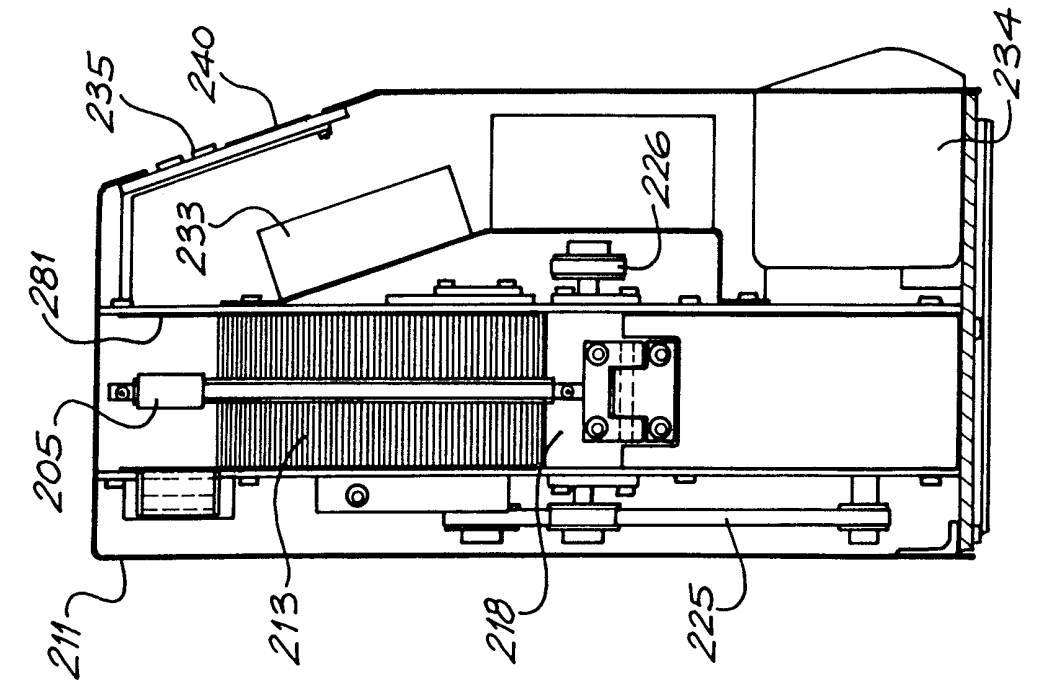

FIG. 7

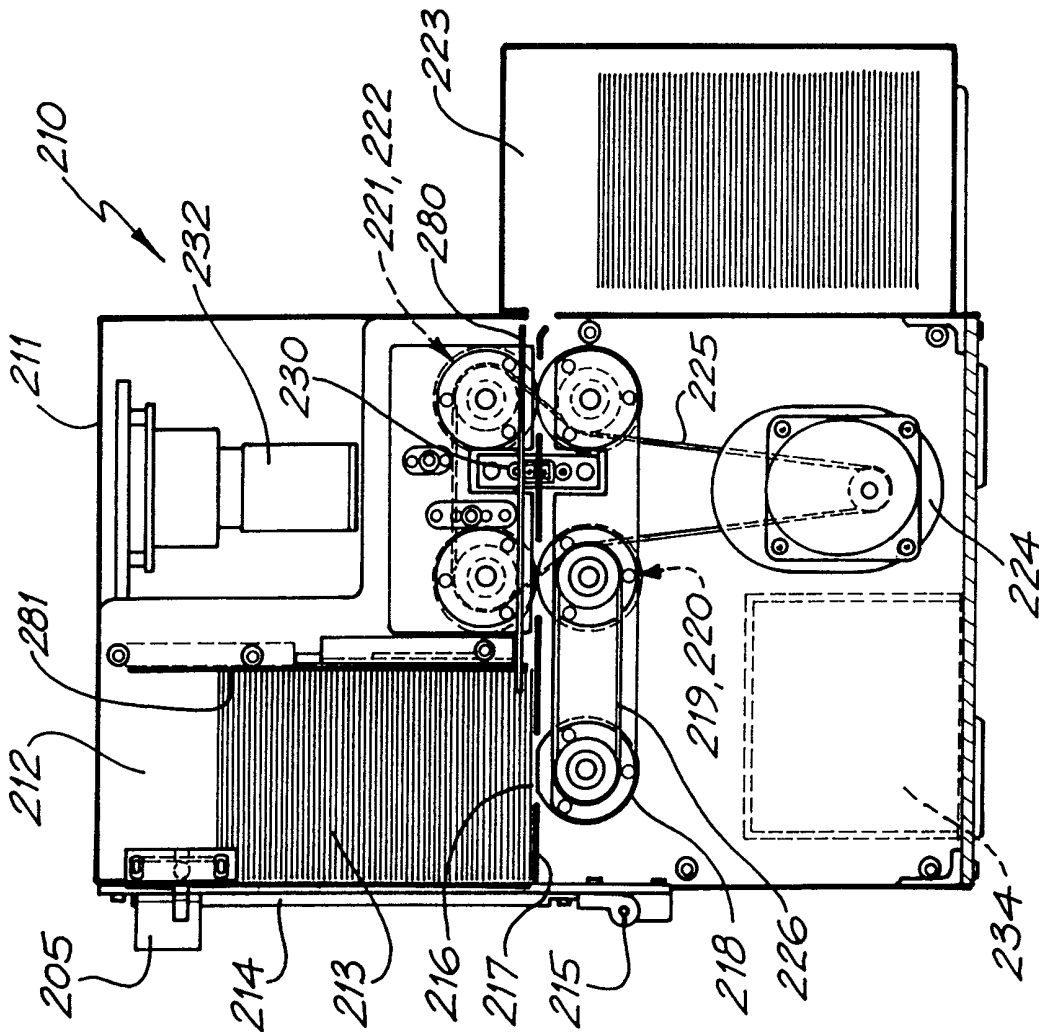

FIG. 8

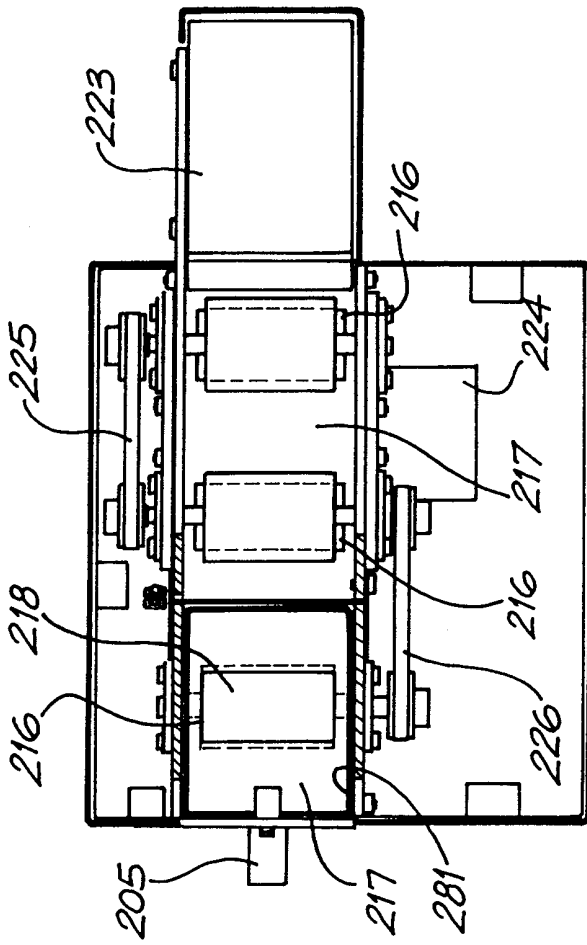

FIG. 10

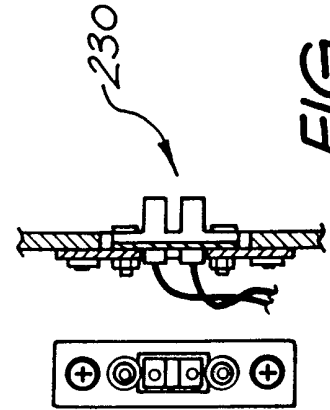

FIG. 11

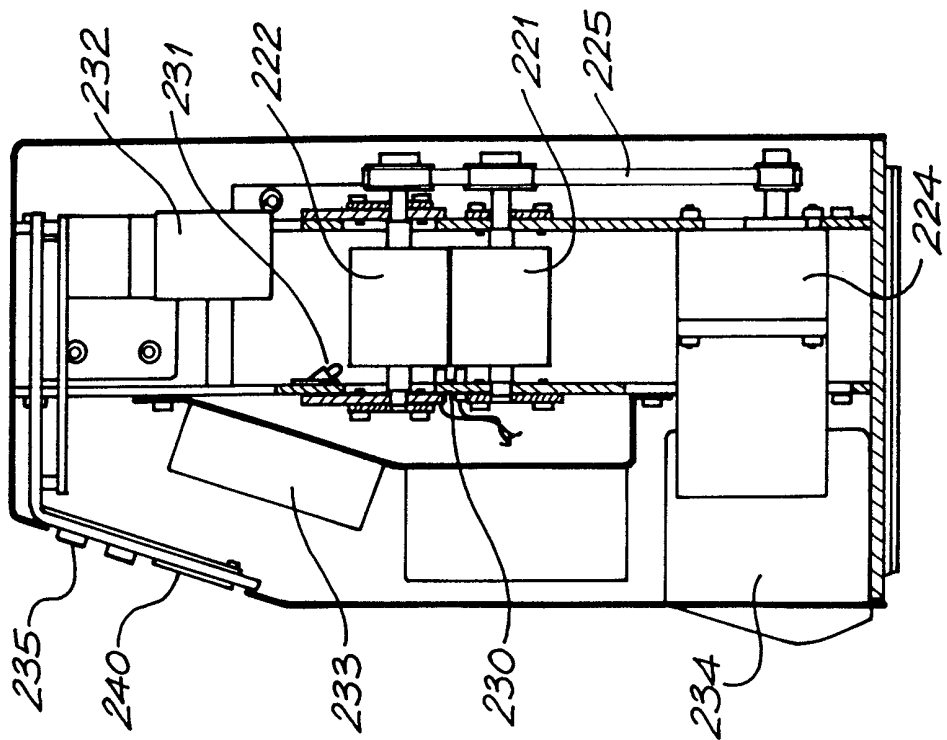

FIG. 9

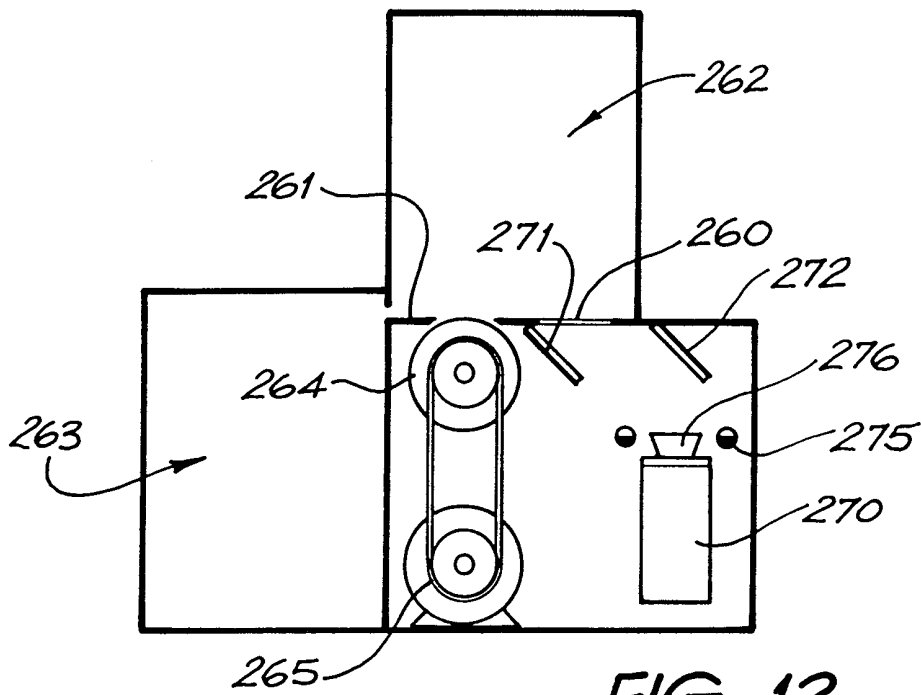

FIG. 12

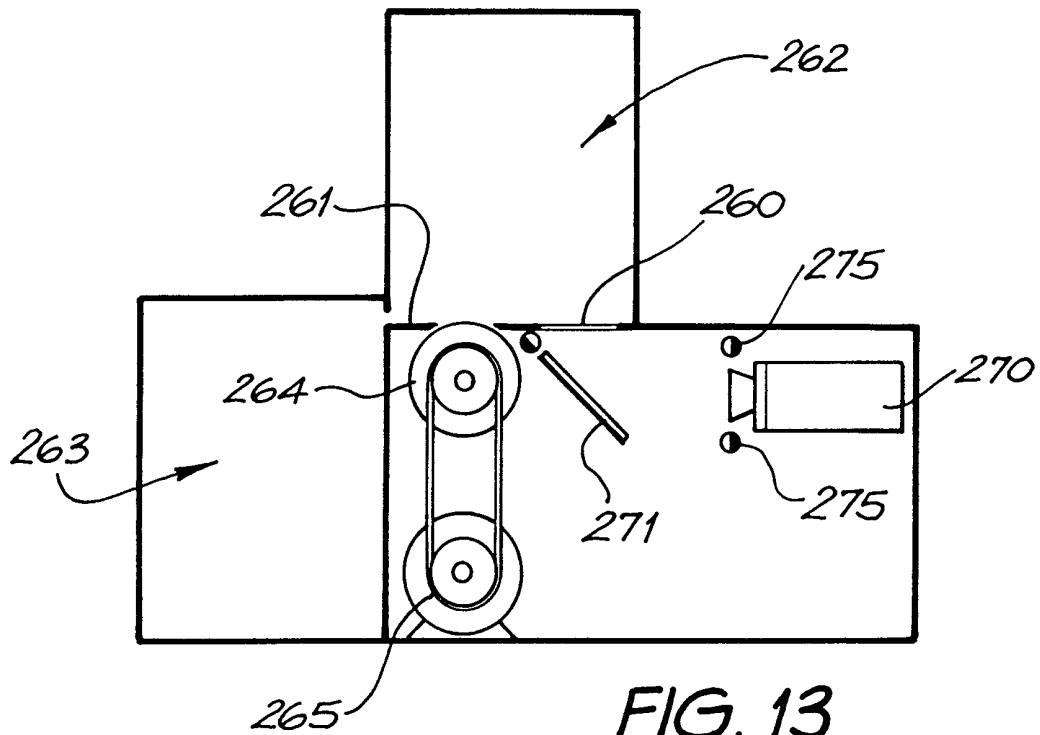

FIG. 13

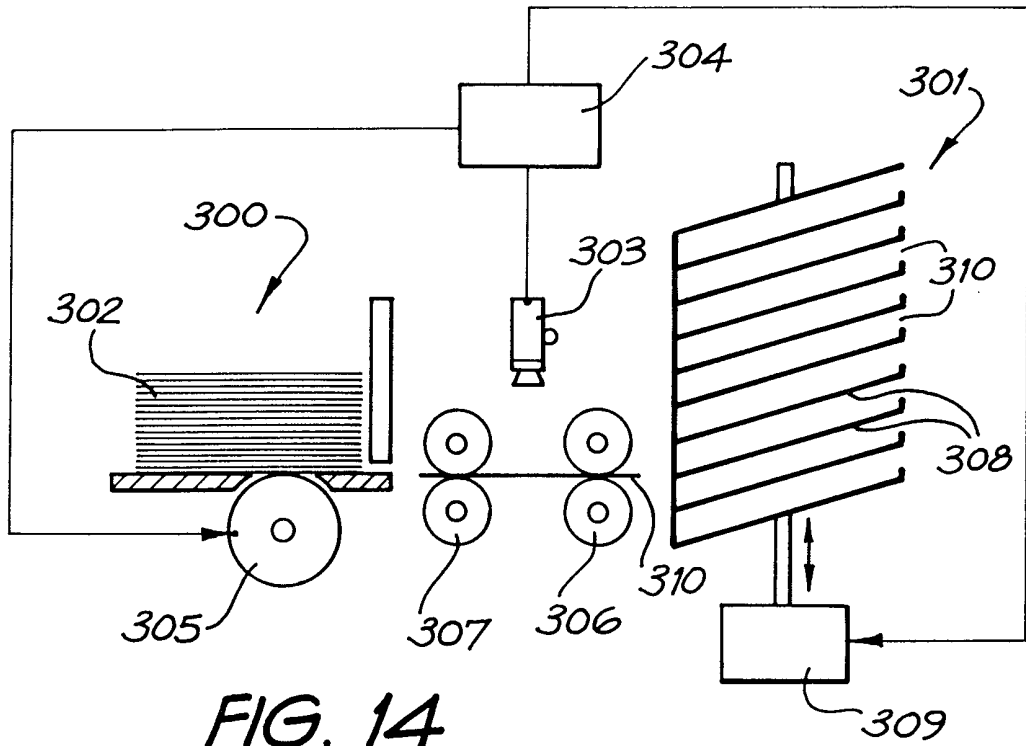

FIG. 14

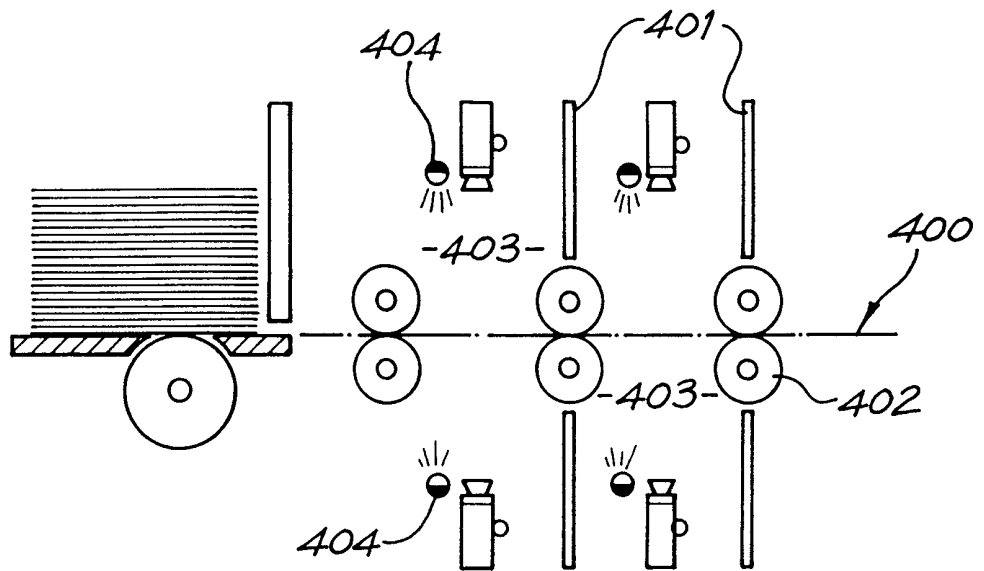

FIG. 15

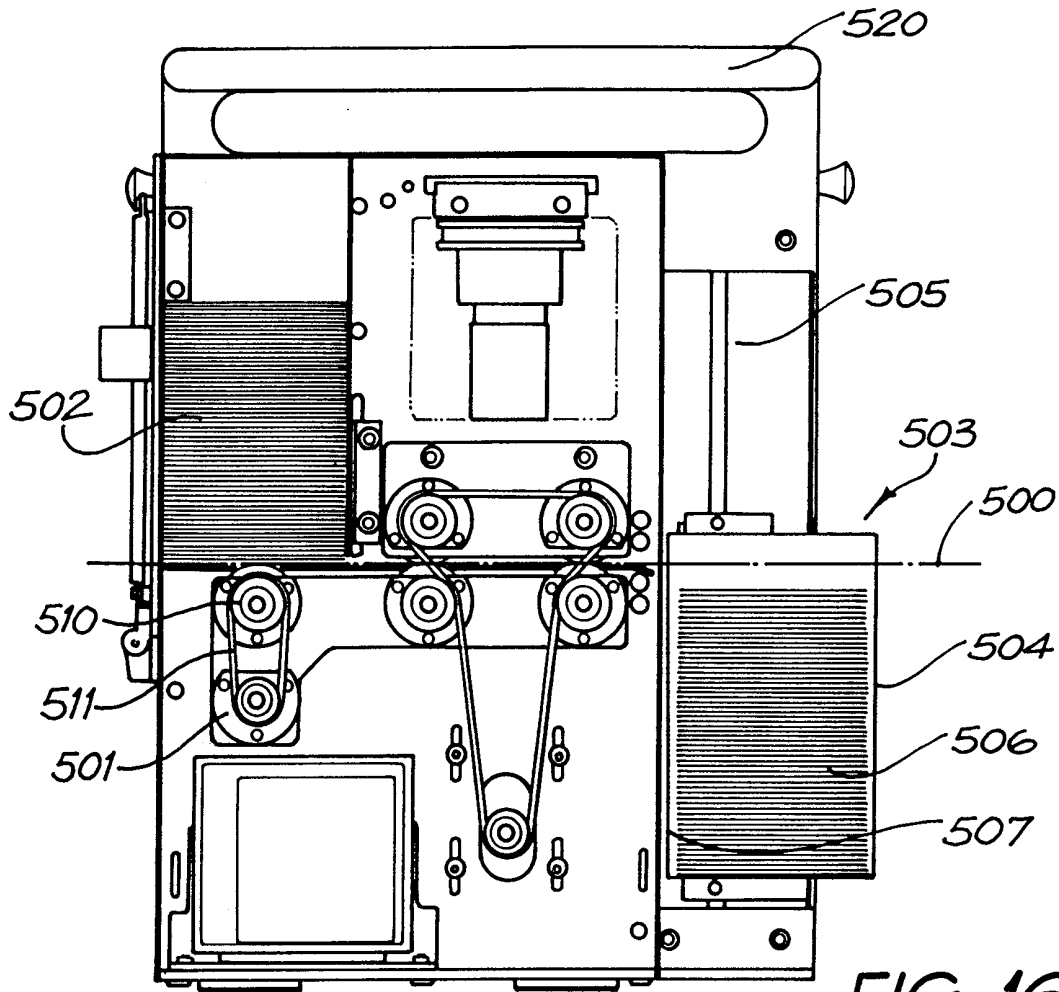

FIG. 16

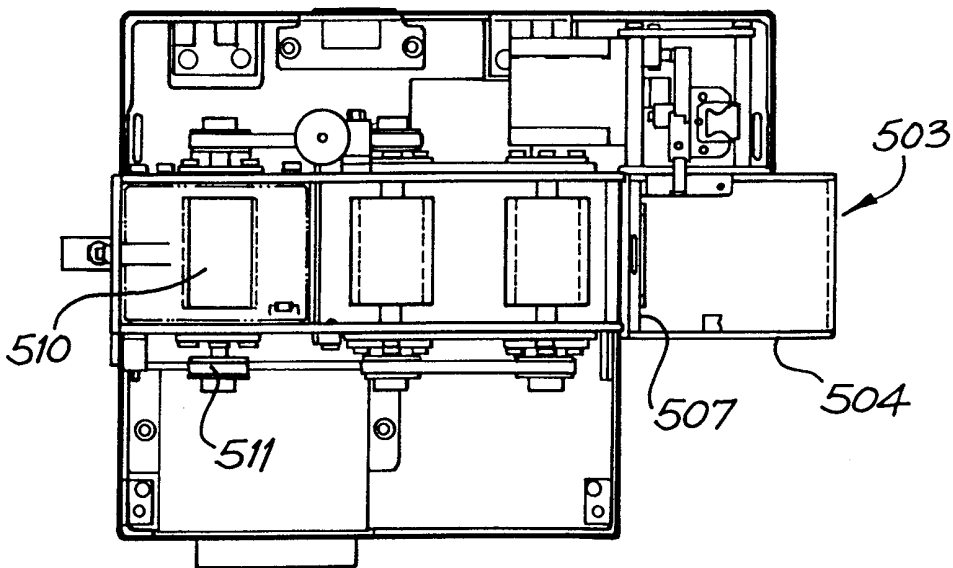

FIG. 17



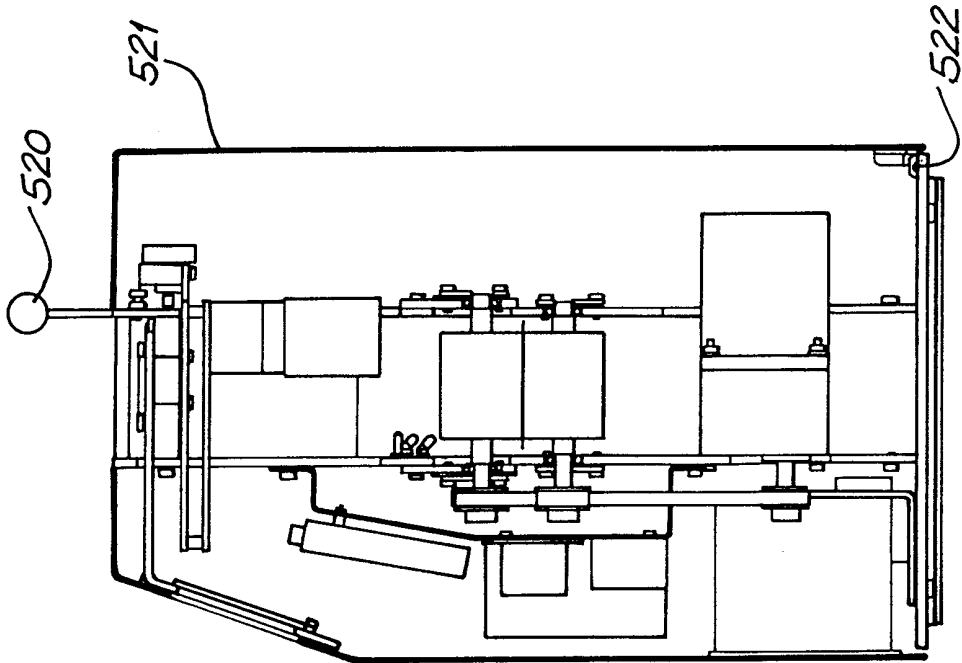

FIG. 19

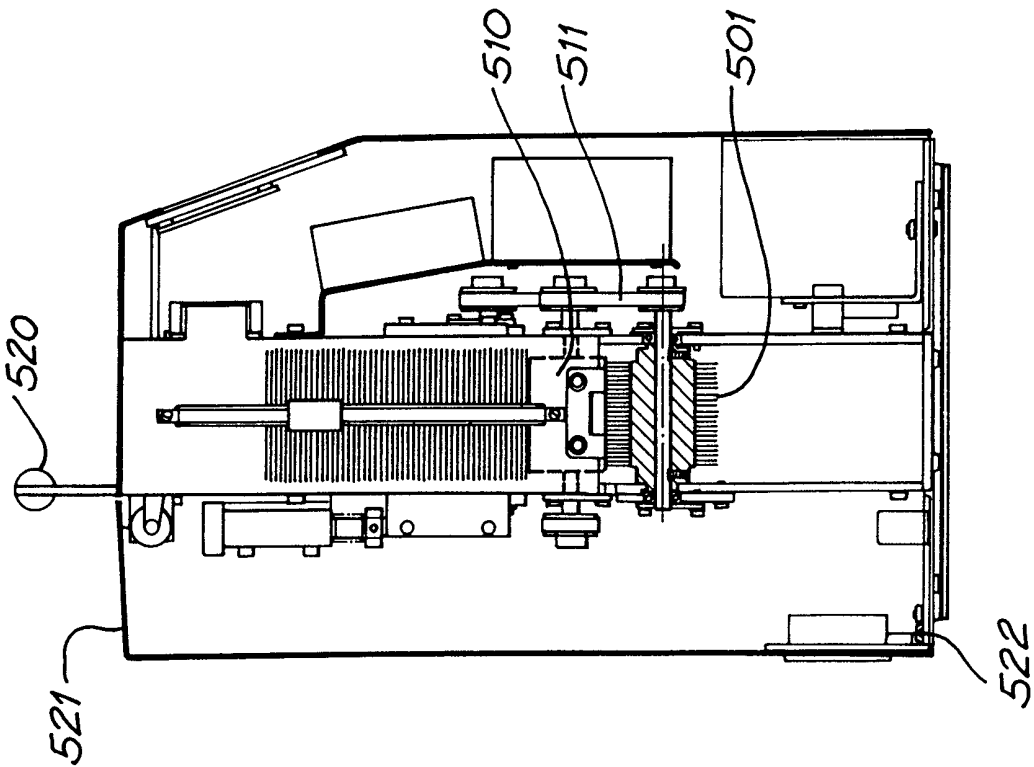

FIG. 18

## INTERNATIONAL SEARCH REPORT

International application No.  
**PCT/AU00/00150**

<b>A. CLASSIFICATION OF SUBJECT MATTER</b>		
Int. Cl. <sup>7</sup> : G06M 7/06, G06K 9/00, A63F 1/06, B07C 1/04		
According to International Patent Classification (IPC) or to both national classification and IPC		
<b>B. FIELDS SEARCHED</b>		
Minimum documentation searched (classification system followed by classification symbols) G06M 7/-, G06K 9/-, A63F 1/06, B07C/-, B65G 57/-, 59/-, 60/-, 61/-,		
Documentation searched other than minimum documentation to the extent that such documents are included in the fields searched		
Electronic data base consulted during the international search (name of data base and, where practicable, search terms used) DWPI & JAPIO		
<b>C. DOCUMENTS CONSIDERED TO BE RELEVANT</b>		
Category*	Citation of document, with indication, where appropriate, of the relevant passages	Relevant to claim No.
X	US 4921109 A (HASUO et al) 1 May 1990 Entire document	14,17-20,
X,	DE 2757341 A (TENAKA SEIKI CO) 29 June 1978, Entire document	1,2,5,6,11
P,X	US 5989122 A (ROBLEJO) 23 November 1999 Entire document	14,16-20
<input checked="" type="checkbox"/> Further documents are listed in the continuation of Box C <input checked="" type="checkbox"/> See patent family annex		
* "A" "E" "L" "O" "P"	Special categories of cited documents: document defining the general state of the art which is not considered to be of particular relevance earlier application or patent but published on or after the international filing date document which may throw doubts on priority claim(s) or which is cited to establish the publication date of another citation or other special reason (as specified) document referring to an oral disclosure, use, exhibition or other means document published prior to the international filing date but later than the priority date claimed	"T" later document published after the international filing date or priority date and not in conflict with the application but cited to understand the principle or theory underlying the invention "X" document of particular relevance; the claimed invention cannot be considered novel or cannot be considered to involve an inventive step when the document is taken alone "Y" document of particular relevance; the claimed invention cannot be considered to involve an inventive step when the document is combined with one or more other such documents, such combination being obvious to a person skilled in the art "&" document member of the same patent family
Date of the actual completion of the international search <b>14 June 2000</b>	Date of mailing of the international search report <b>20 JUN 2000</b>	
Name and mailing address of the ISA/AU AUSTRALIAN PATENT OFFICE PO BOX 200, WODEN ACT 2606, AUSTRALIA E-mail address: pct@ipaaustralia.gov.au Facsimile No. (02) 6285 3929	Authorized officer  <b>MANO RAMACHANDRAN</b> Telephone No : (02) 6283 2166	

## INTERNATIONAL SEARCH REPORT

International application No.

PCT/AU00/00150

C (Continuation). DOCUMENTS CONSIDERED TO BE RELEVANT		
Category*	Citation of document, with indication, where appropriate, of the relevant passages	Relevant to claim No.
X	Derwent Abstract Accession No. 97-217497/20, Class T01 T04 T05, JP 09-062753 A (GLORY KOGYO KK) 7 March 1997 Abstract	1
Y	Derwent Abstract Accession No. 97-057366/06, Class W04, JP 08-305808 A (YAC KK ) 22 November 1996 Abstract	1,
Y	Derwent Abstract Accession No. 99-200652/17, Class T05, JP 11-045321 A (TAKAMISAWA CYBERNETICS) 16 February 1999 Abstract	1,6,11
P,A	US 6053695 A (LONGORIA et al) 25 April 2000 Abstract	

**INTERNATIONAL SEARCH REPORT**  
Information on patent family members

International application No.  
**PCT/AU00/00150**

This Annex lists the known "A" publication level patent family members relating to the patent documents cited in the above-mentioned international search report. The Australian Patent Office is in no way liable for these particulars which are merely given for the purpose of information.

Patent Document Cited in Search Report				Patent Family Member	
US	4921109	JP	61-253535	JP	62-074844
US	6053695	AU	87132/98	BR	9804285
<b>END OF ANNEX</b>					