

- [54] SYSTEMS FOR MONITORING YARNS IN MULTICOIL PRODUCTION TEXTILE MACHINES
- [75] Inventor: Ernst Felix, Uster, Switzerland
- [73] Assignee: Zellweger, Ltd., Uster Factories for Apparatus and Machines, Uster, Switzerland
- [22] Filed: June 9, 1972
- [21] Appl. No.: 261,409
- [30] Foreign Application Priority Data
June 10, 1971 Switzerland..... 8437/70
- [52] U.S. Cl. 57/81
- [51] Int. Cl. D01h 13/16
- [58] Field of Search 57/1, 34 R, 80, 81, 88

[56] **References Cited**

UNITED STATES PATENTS

3,523,415	8/1970	Suzuki	57/81
R27,501	10/1972	Bryan et al.	57/81 X
3,364,670	1/1968	Stiepel et al.	57/88
3,084,499	4/1963	Harvey.....	57/81
2,576,936	12/1951	Heffelfinger	57/80

Primary Examiner—Donald E. Watkins
Attorney, Agent, or Firm—Craig and Antonelli

[57] **ABSTRACT**

A circuit for monitoring yarns in multicoil production machines in the textile industry wherein the outputs of a plurality of feelers associated with respective yarns are logically analyzed to detect respective yarn break conditions and suitably control the operation of individual coils or the entire machine.

7 Claims, 3 Drawing Figures

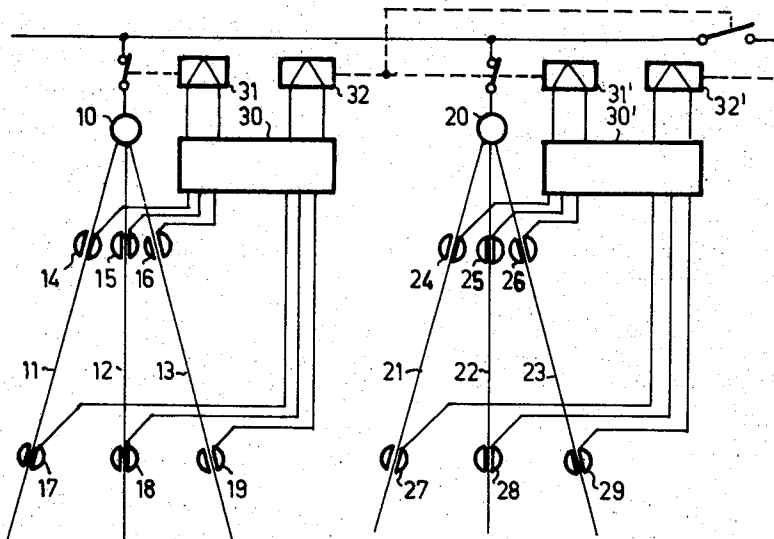

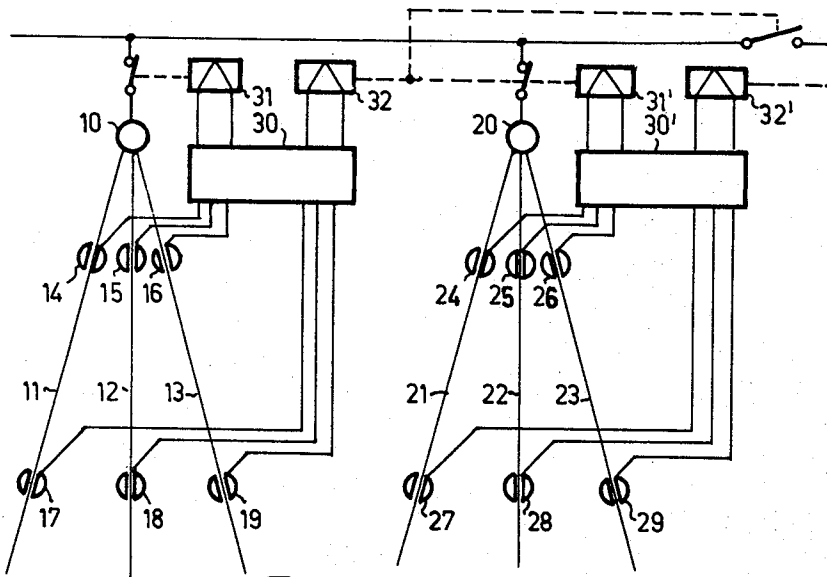

Fig. 1

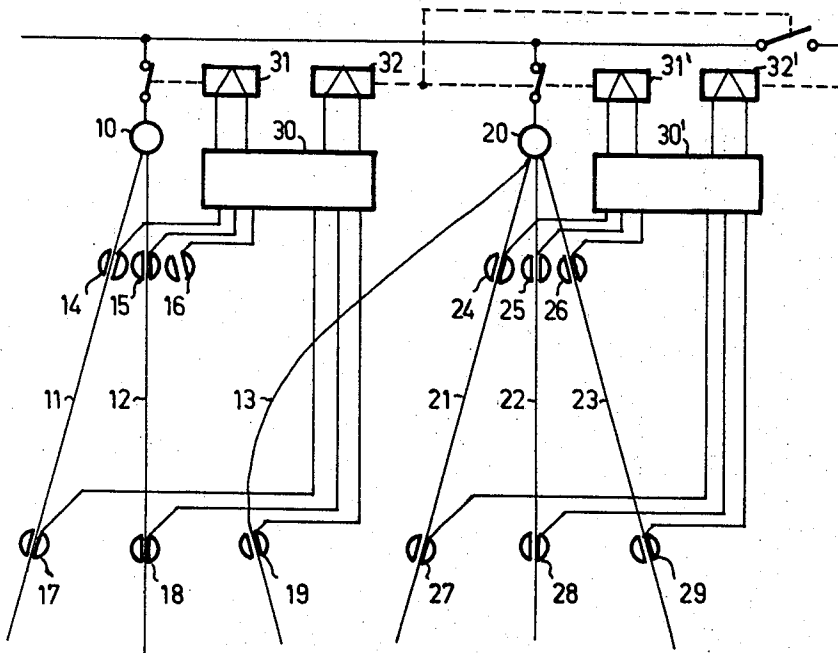

Fig. 2

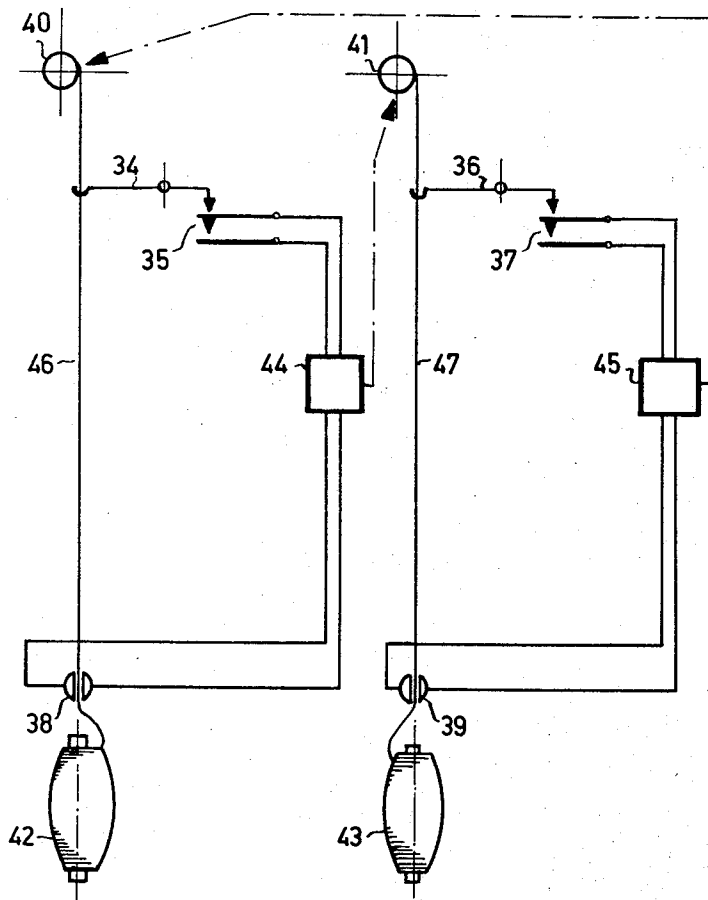

Fig. 3

SYSTEMS FOR MONITORING YARNS IN MULTICOIL PRODUCTION TEXTILE MACHINES

The present invention relates in general to textile machines, and more particularly to improvements in or relating to circuits for monitoring yarns in multicoil production machines in the textile industry.

In the textile industry it is a requirement that each yarn be monitored continuously during the spinning thereof. For this reason yarn feelers are used which will stop the respective coil on which the broken yarn has been manufactured upon detection of a break in that yarn.

For example, in twisting machines, machines for texturization or similar machines, several individual yarns are concentrated on each coil. Each of these individual yarns has to be monitored by a yarn feeler which stops the respective coil as soon as one yarn is broken. Similarly, at textile machines with only one yarn at each coil, the situation can arise that on this one coil a broken yarn from a neighboring coil can be seized and wound up.

Another very serious situation can occur wherein the yarn at one coil breaks and the thereby produced yarn end will become engaged with a yarn of a neighboring coil and will be wound thereon in an incorrect manner. Consequently, the coil with the broken yarn will be switched off, but an additional yarn will be undesirably wound on the neighboring coil without this coil being switched off by its yarn feeler. It is therefore a requirement that on the occurrence of such a faulty condition the entire machine, or at least the neighboring coils, also be stopped.

It is therefore an object of the present invention to provide a monitoring arrangement for textile yarns which is capable of detecting various combinations of yarn break conditions in multicoil textile production machines.

It is another object of the present invention to provide a monitoring arrangement which will individually control respective coils as well as the operation of the entire machine automatically in response to selective combinations of yarn break conditions.

It is a further object of the present invention to provide a monitoring arrangement of the type described which is extremely simple in construction and therefore dependable in use, including means to logically discriminate between the possible combinations of yarn break conditions and control the operation of the machine in response thereto.

The present invention dealing with these requirements comprises an arrangement including at least one feeler for each coil, wherein by logic combination of the signals produced by the feelers a resulting signal for a correct or incorrect operation is obtained. Yarn feelers are advantageously provided as so-called thermosensors, disclosed for example in U.S. Pat. application Ser. No. 97,661 of Dec. 14, 1970 now U.S. Pat. No. 3,756,524. The logic combination of the signals produced by each of the yarn feelers controls a certain switching condition and this switching condition is changed as soon as one of the signals drops out to produce a new combination which requires this change.

These and other objects, features and advantages of the present invention will become more apparent from the following detailed description when taken with the

accompanying drawings, which illustrate two exemplary embodiments of the invention, and wherein:

FIG. 1 is a schematic diagram showing two neighboring coils with yarn feelers under correct operating conditions;

FIG. 2 is a schematic diagram showing two neighboring coils with yarn feelers under incorrect operating conditions; and

FIG. 3 is a schematic diagram showing two neighboring coils with simple running yarns.

In the examples according to FIGS. 1 and 2, multifilament production machines are illustrated; however, the inventive principle can also be applied to production machines with only a single yarn per coil.

In FIG. 1, references 10 and 20 designate respective spinning or twisting points, for example, on twisting or similar textile machines. The three yarns 11, 12 and 13 run up to the spinning point 10 and the yarns 21, 22 and 23 up to the neighboring spinning place 20. Each of the yarns is monitored by means of at least one yarn feeler. These yarn feelers are provided in such a manner that they produce a signal, for instance, as long as the yarn runs therethrough; whereas, this signal is interrupted if no yarn is detected by the feeler. For a definite examination of the yarn it is advantageous if one yarn monitor (14, 15 and 16; 24, 25 and 26) is situated near the spinning point (10; 20) and further yarn monitors (17, 18 and 19; 27, 28 and 29) immediately near the reserve coil (not shown).

As soon as a yarn breaks, the corresponding yarn feeler reacts and the evaluating unit 30 gives a signal to, for example, a relay 31 which stops the spinning point 10. In this regard, the signals provided by both feelers associated with the broken yarn will be interrupted, which condition is recognized by the evaluating unit 30 as an indication that only spinning point 10 is to be stopped.

If there occurs another working condition, for example as seen in FIG. 2, wherein yarn 13 breaks and the end of this yarn is blown away by an air stream to yarn 21 of the neighboring spinning point so as to be seized therefrom and coiled onto spinning point 20, only the yarn feeler 16 detects the absence of a yarn, and accordingly spinning point 10 will be stopped. However, the corresponding signals at the evaluating unit 30 must, according to the invention, indicate the condition of an incorrect operation in connection with an adjacent spinning point, for example by means of the signal derived from feeler 19, and operate a further relay 32 so as to trigger the stopping of the entire machine, or as a variant, the stopping of the spinning point which is situated close to spinning point 10.

In the example shown in FIG. 3 mechanical yarn feelers 34, 36 close to spinning points 40, 41 are shown, which for example produce in connection with contactors 35, 37 an electrical signal as soon as one of the yarns 46, 47 is interrupted. A further pair of electronic yarn feelers 38, 39 is placed close to the coils 42, 43. Both the contacts of the mechanical yarn feelers 34, 36 and the outputs of the electronic yarn feelers 38, 39 are connected to the evaluating circuits 44, 45 which detect the logic combinations of signals at the output terminals and control the switches working on the respective or the adjacent spinning point.

In FIGS. 1 to 3, for each yarn two yarn feelers are used. Yarn feelers can be of any conventional construction, if they detect a yarn break and are capable of pro-

ducing a stopping of the spinning point. Consequently, both mechanical and electronic yarn feelers are useful for producing the logic combinations necessary to operation of the evaluating unit.

A detailed description of the evaluating unit for operating on the logic combinations is not required since such logic circuits formed by a combination of AND and OR gates are known to those skilled in the art. A complete understanding of the logic circuitry will be clear from the definitions of the logic combinations. The logic combinations of the yarn feeler signals which have to be recognized in the evaluating units 30, 30' and 44, 45, respectively, and the control required thereby correspond to the following conditions:

1. If both yarn feelers associated with a respective yarn produce a signal, the evaluating unit should render productive all coils;
2. If both yarn feelers associated with a respective yarn produce no signal, the evaluating unit should stop the respective coil, for example by means of a switching device such as relay 31 in FIG. 1;
3. If only one yarn feeler associated with a respective yarn produces a signal, the evaluating unit should generate a signal which stops the neighboring coils or the entire machine, for instance by means of a switching device such as relay 32 in FIG. 1.

In production machines with multi-filament coils simplified performances are also possible with only one yarn feeler for each yarn, using either a mechanical or an electronic yarn feeler. This is admissible since the probability is extremely small that incorrect working conditions will coincide to produce a simultaneous break of yarns 11 and 12.

The circuit arrangement is useful also for rovings and slivers. The monitoring is effected in these cases not by means of yarn feelers, but generally by feelers. Of special interest is the monitoring of spinning frames of the ring spinning system for worsted yarns, where normally two rovings are combined on one coil and the feelers are placed directly before the drafting zone. If two rovings are present, the working conditions are normal. If both rovings are absent, this can be the fault of the roving coils, which means that no serious disturbance is present. If, however, only one roving is present, probably the serious case is present that the second roving is wound on a false coil. In this case a special control signal has to be produced to stop the spinning frame.

What is claimed is:

1. Circuit for monitoring yarns in a multicoil textile machine comprising at least one yarn feeler associated with each yarn providing a control signal in the absence of detection of the yarn and logic control means responsive to a plurality of said control signals for selectively controlling the operation of said textile machine, each coil of the machine being associated with a plurality of yarns and at least two yarn feelers being associated with each yarn at spaced points along the length thereof, said logic control means including control means for stopping the operation of said coils, and logic

circuit means responsive to absence of control signals from both yarn feelers associated with the same yarn for actuating said control means to stop the coil associated with that yarn.

2. Circuit for monitoring yarns in a multicoil textile machine comprising at least one yarn feeler associated with each yarn providing a control signal in the absence of detection of the yarn and logic control means responsive to a plurality of said control signals for selectively controlling the operation of said textile machine, each coil of the machine being associated with a plurality of yarns and at least two yarn feelers being associated with each yarn at spaced points along the length thereof, said logic control means including control means for stopping the operation of said coils, and logic circuit means responsive to receipt of a control signal from only one yarn feeler associated with a given yarn for actuating said control means to stop the coil associated with that yarn and at least one adjacent coil.
3. Circuit according to claim 2 wherein said logic circuit means is responsive to receipt of a control signal for only one yarn feeler associated with a given yarn for actuating said control means to stop all of the coils of the machine.
4. Circuit for monitoring yarns in a multicoil textile machine comprising at least one yarn feeler associated with each yarn providing a control signal in the absence of detection of the yarn and logic control means responsive to a plurality of said control signals for selectively controlling the operation of said textile machine, said logic control means including control means for stopping the operation of said coils, and logic circuit means responsive to absence of control signals from at least two yarn feelers associated with adjacent yarns attached to the same coil for actuating said control means to stop that coil and at least one adjacent coil.
5. Circuit according to claim 4 wherein said logic circuit means is responsive to absence of control signals from at least two yarn feelers associated with adjacent yarns attached to the same coil for actuating said control means to stop all of the coils of the machine.
6. Circuit for monitoring yarns in a multicoil textile machine comprising at least one yarn feeler associated with each yarn providing a control signal in the absence of detection of the yarn and logic control means responsive to a plurality of said control signals for selectively controlling the operation of said textile machine, two yarns being combined on each coil and said logic control means including control means for stopping the operation of said coils, and logic circuit means for detecting absence of a control signal from only one yarn feeler for actuating said control means to stop the associated coil and at least one adjacent coil.
7. Circuit according to claim 6 wherein said logic circuit means is responsive to the absence of a control signal from only one yarn feeler for actuating said control means to stop all of the coils of the machine.

* * * * *