



US00D574792S

(12) **United States Design Patent**
Sato

(10) **Patent No.:** **US D574,792 S**

(45) **Date of Patent:** **** Aug. 12, 2008**

(54) **LOWER HEAT INSULATING CYLINDER FOR MANUFACTURING SEMICONDUCTOR WAFERS**

Primary Examiner—Selina Sikder
(74) *Attorney, Agent, or Firm*—Smith, Gambrell & Russell, LLP

(75) Inventor: **Izumi Sato**, Tokyo (JP)

(73) Assignee: **Tokyo Electron Limited**, Tokyo (JP)

(**) Term: **14 Years**

(21) Appl. No.: **29/272,820**

(22) Filed: **Feb. 20, 2007**

(30) **Foreign Application Priority Data**

Aug. 23, 2006 (JP) 2006-022201

(51) **LOC (8) Cl.** **13-03**

(52) **U.S. Cl.** **D13/182**

(58) **Field of Classification Search** D13/182;
118/715; 206/454, 711; 211/41.18; 432/253
See application file for complete search history.

(56) **References Cited**

U.S. PATENT DOCUMENTS

5,534,074	A *	7/1996	Koons	118/728
D404,375	S *	1/1999	Shimazu	D13/182
D405,428	S *	2/1999	Ishii	D13/182
6,033,215	A *	3/2000	Ohsawa	432/258
6,171,400	B1 *	1/2001	Wingo	118/500
2002/0092815	A1 *	7/2002	Kim et al.	211/41.18
2004/0069732	A1 *	4/2004	Huang et al.	211/183
2005/0145584	A1 *	7/2005	Buckley et al.	211/41.18

OTHER PUBLICATIONS

Copending U.S. Appl. No. 29/272,821, filed Feb. 20, 2007, "Upper Heat Insulating Cylinder for Manufacturing Semiconductor Wafers".

* cited by examiner

(57) **CLAIM**

The ornamental design for a lower heat insulating cylinder for manufacturing semiconductor wafers, as shown and described.

DESCRIPTION

FIG. 1 is a perspective view of the design for a lower heat insulating cylinder for manufacturing semiconductor wafers in accordance with the invention;

FIG. 2 is a front view thereof;

FIG. 3 is a left side view thereof;

FIG. 4 is a right side view thereof;

FIG. 5 is a rear view thereof;

FIG. 6 is a top view thereof;

FIG. 7 is a bottom view thereof;

FIG. 8 is another top view thereof which shows sectional line 9—9;

FIG. 9 is a sectional view thereof along line 9—9 of FIG. 8; and,

FIG. 10 shows a lower heat insulating cylinder for manufacturing semiconductor wafers in accordance with the invention in use wherein the broken line showing of the environment is for illustrative purpose only and forms no part of the claimed design.

1 Claim, 10 Drawing Sheets

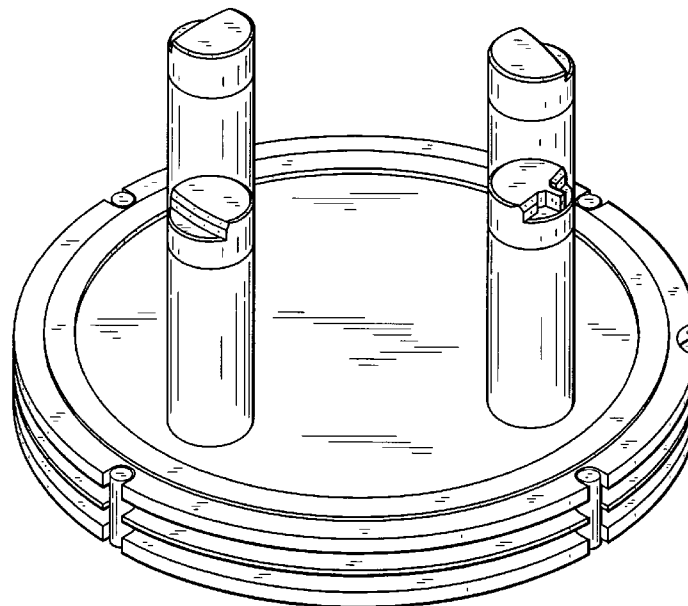

FIG. 1

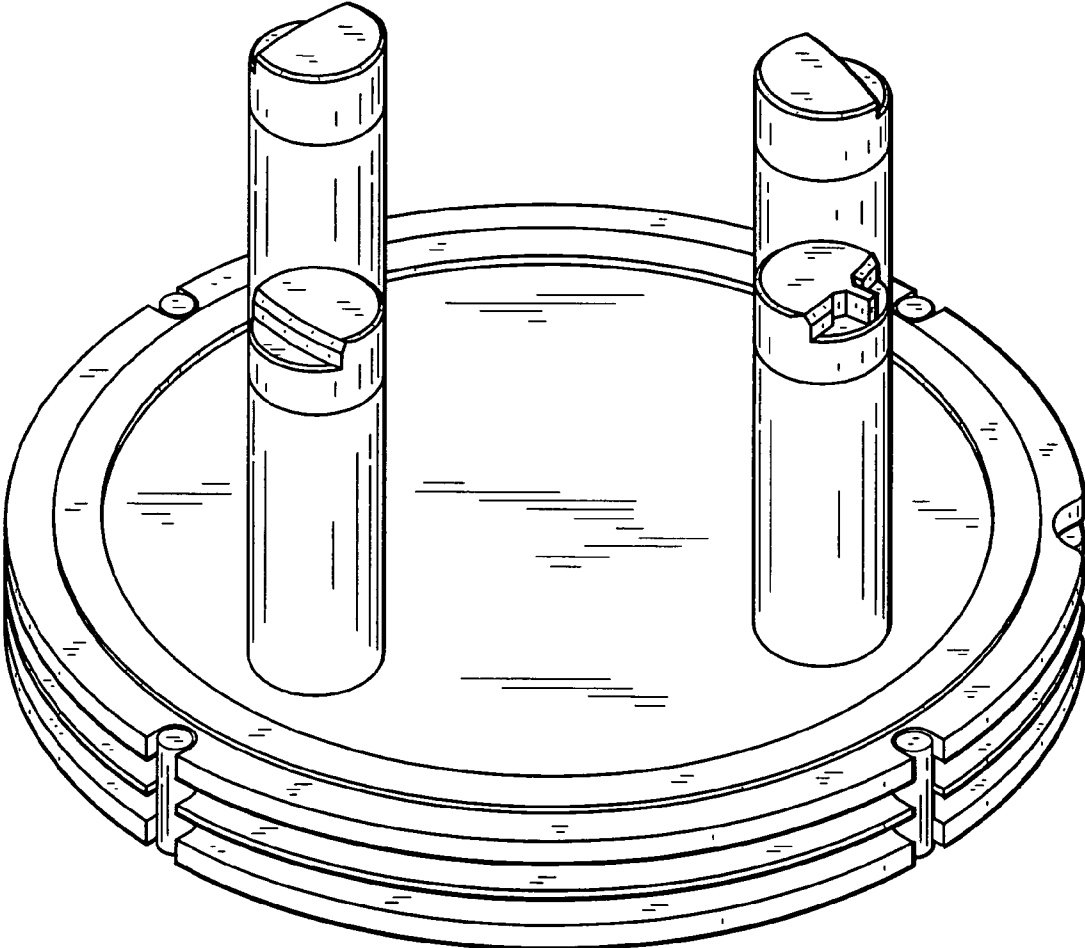

FIG. 2

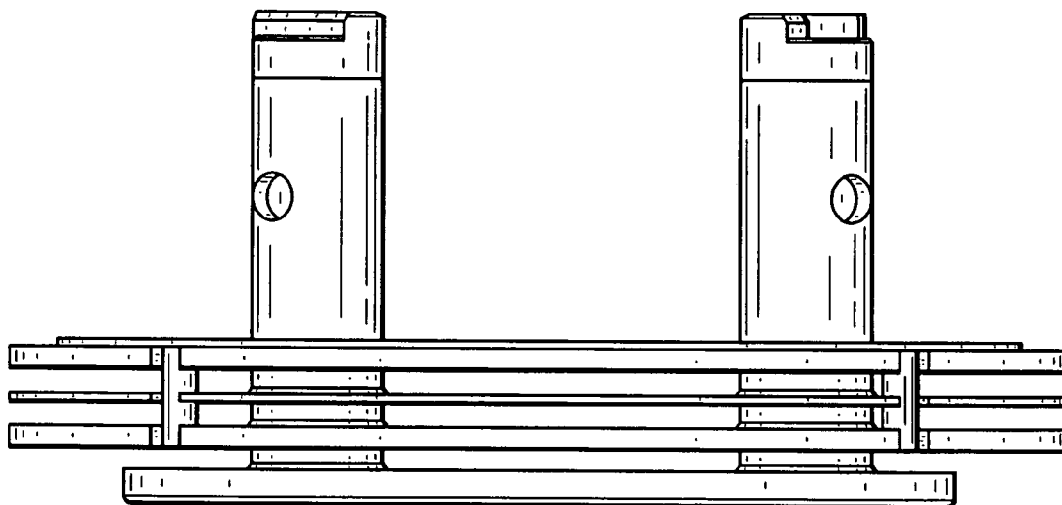

FIG. 3

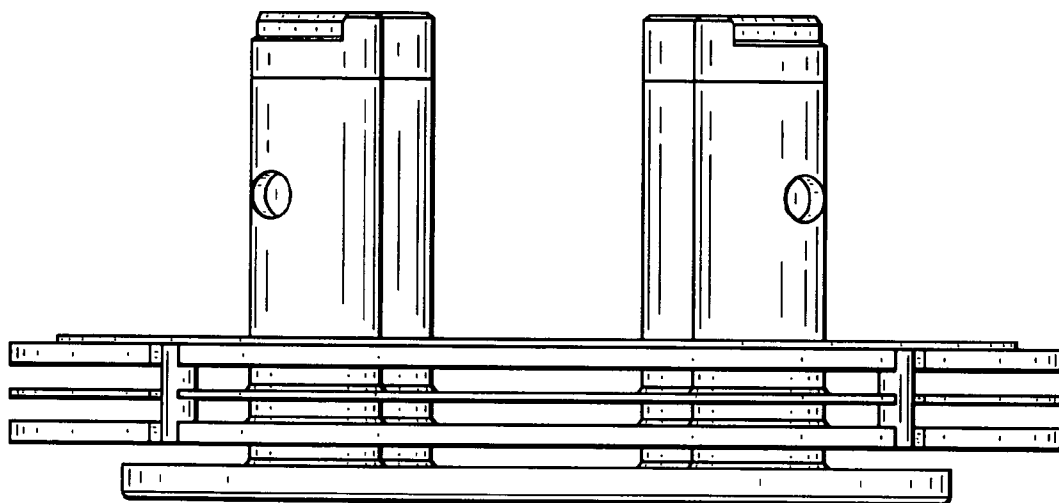

FIG. 4

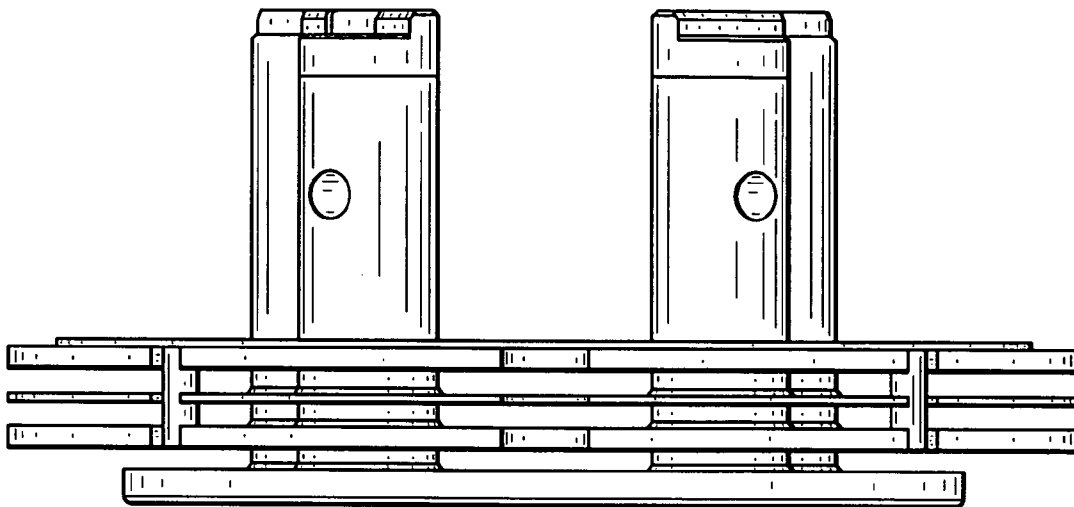

FIG. 5

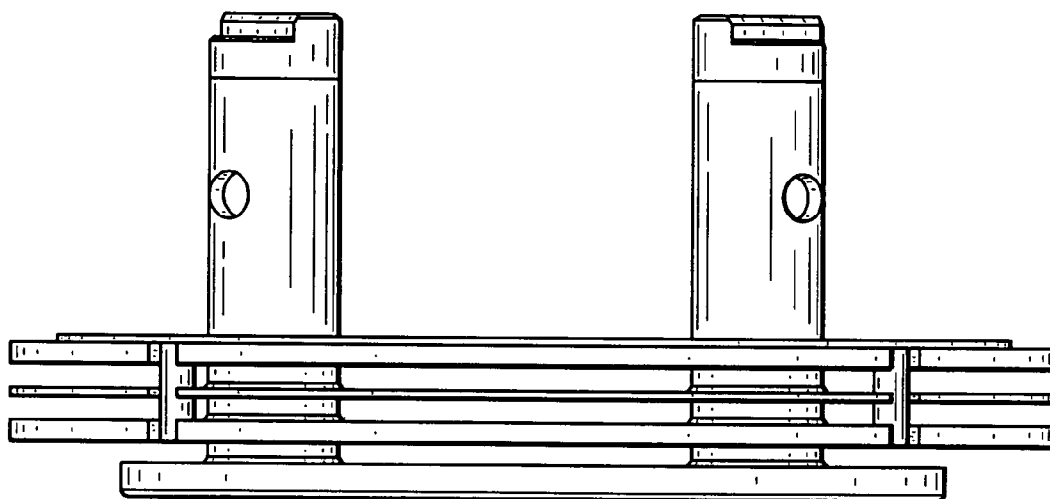

FIG. 6

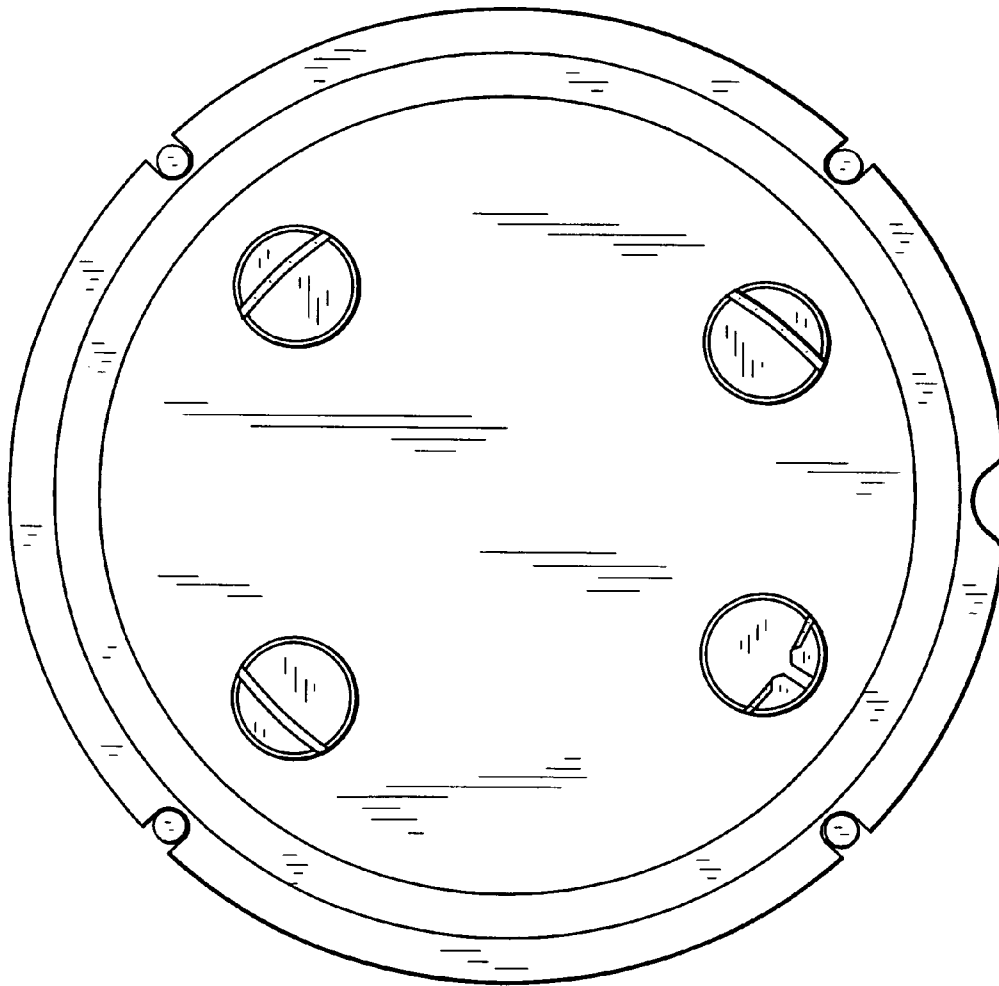

FIG. 7

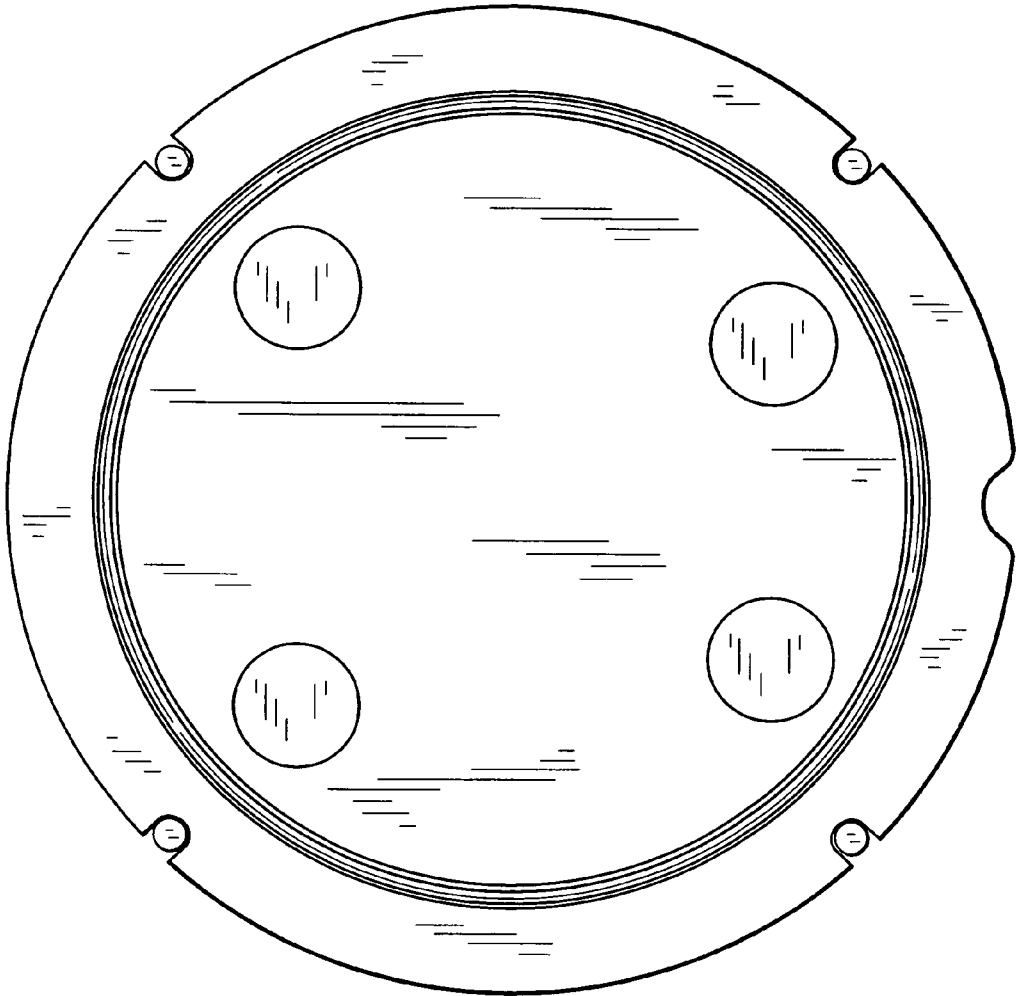

FIG. 8

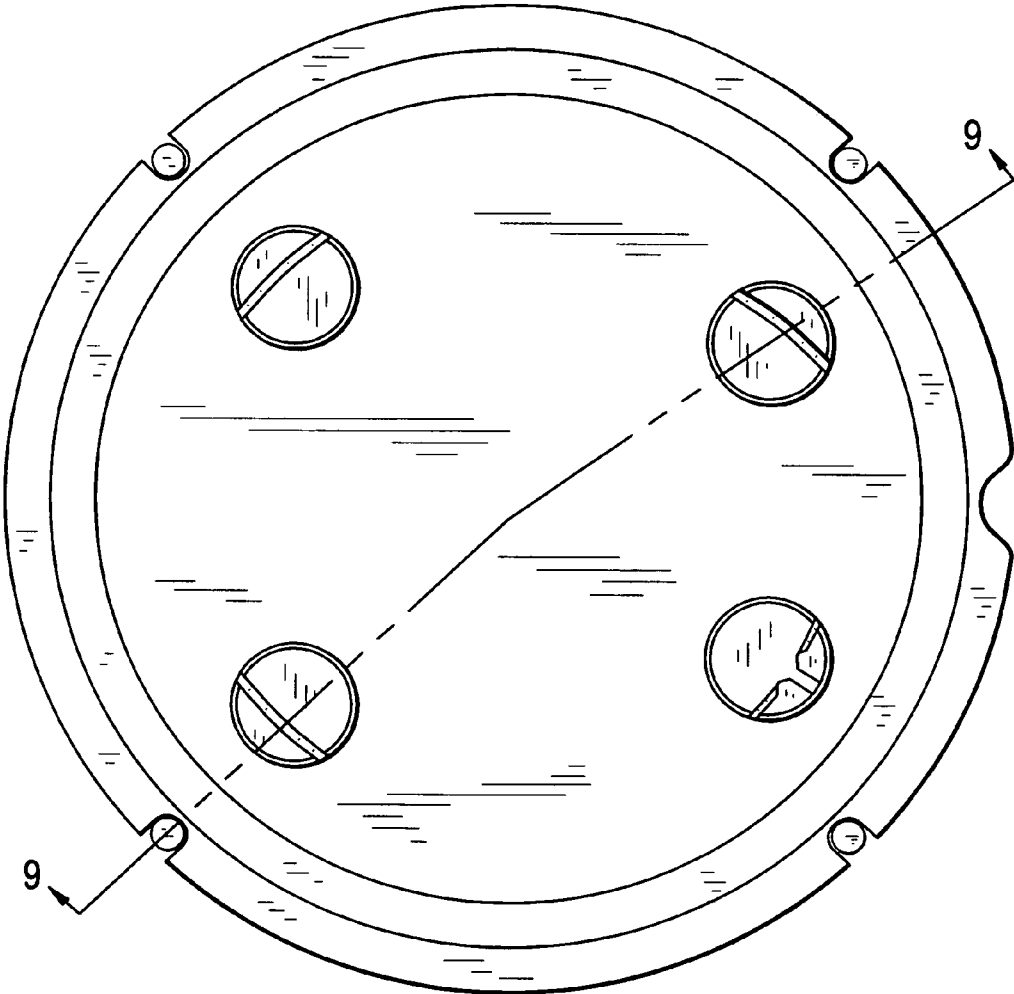

FIG. 9

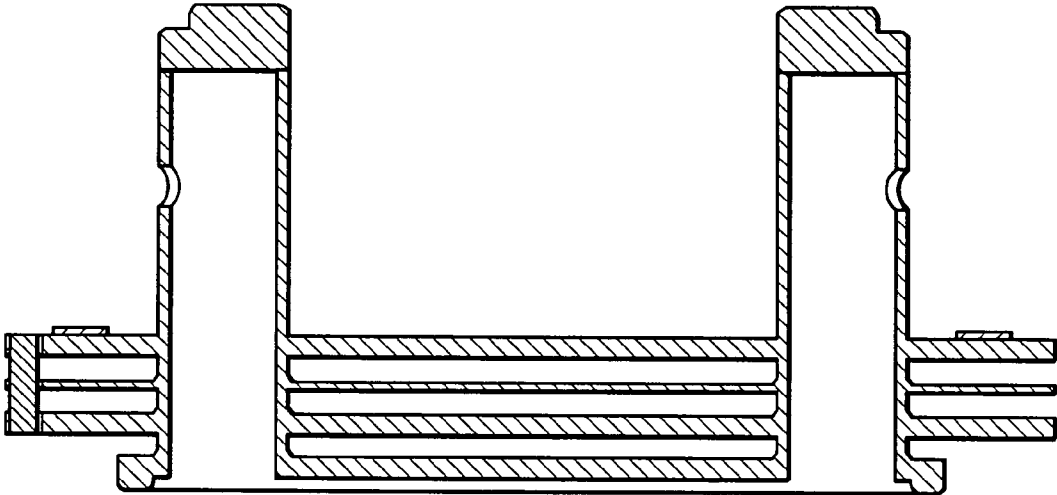

FIG. 10

