

(19)  
(12)

(KR)  
(B1)

(51) 。 Int. Cl.7  
H04R 19/04

(45)  
(11)  
(24)

2004 04 27  
10-0427770  
2004 04 07

(21) 10-2001-0018565  
(22) 2001 04 09

(65)  
(43)

10-2002-0078269  
2002 10 18

(73)

254-3

(72)

2 1321-6

1204

(74)

:

(54)

가

가

2e

- 1
- 2
- a)
- b),c)
- d)
- e)
- 3
- \*
- 1: 2:

1

2

3

\*

10: 11:  
12: 13:

1

4 $\mu$ m (100)  
(102)

(101) 0.012mm~0.025mm (102) 0.025mm 0.038mm  
(103)가

(102) (104) (105) FET(106) (107)  
4 $\mu$ m (100) 가

(108) 4 $\mu$ m

(100) 가 (108) (103)

(100) FET(107)

(102) (105)  
가 가가

가

가

가

가

2

0.1mm 가 0.3mm (1)

(1) 2

(2)가  
가

12 $\mu$ m  
1

25 $\mu$ m (2) 가

1,2 가

3  
가

(3)

(2)가

(1) 가 (2) ,  
 (10) (11) (12) , (13)  
 (14) 가 가  
 가 , 가  
 가

(57)

1.  
 (10) (11) (12)가 , (12) (13) ,  
 (10) (13) (2)가  
 (2) 12 $\mu$ m 25 $\mu$ m , 0.1mm 0.3mm (1)  
 (2) 1 2 3 ,  
 2.

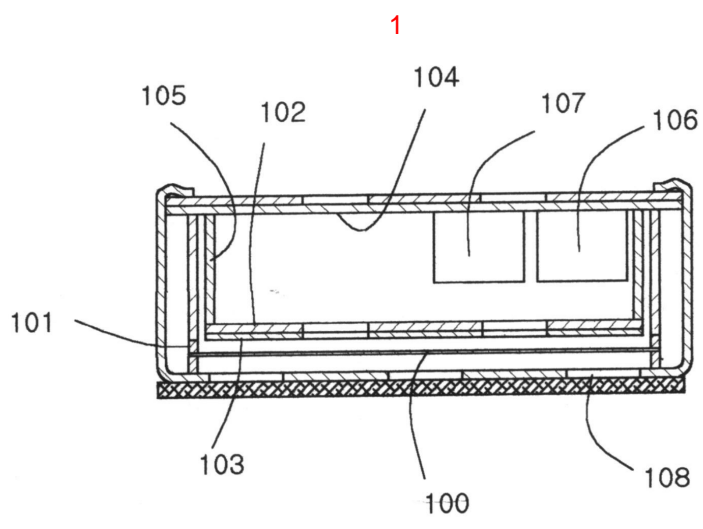

2a

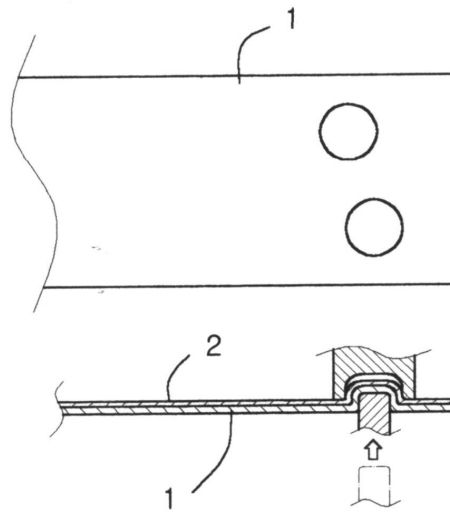

2b

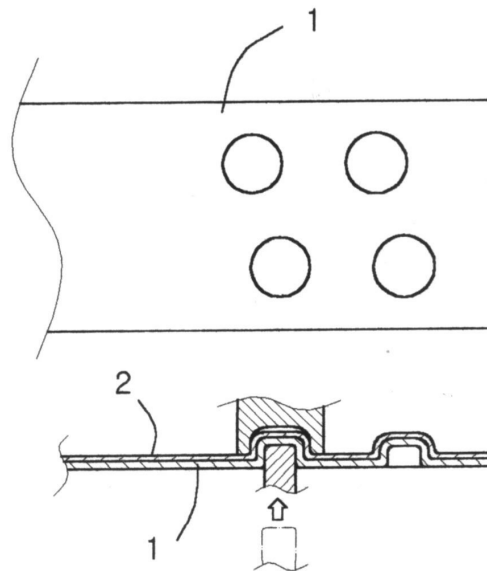

2c

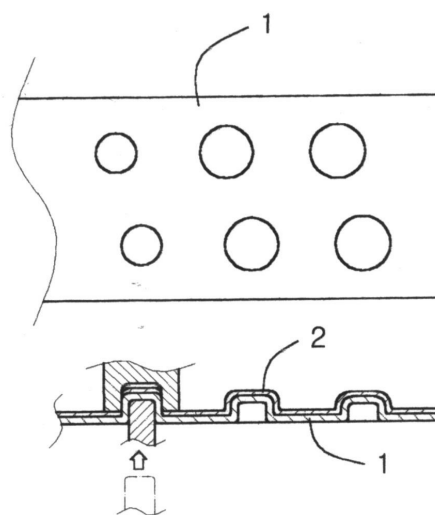

2d

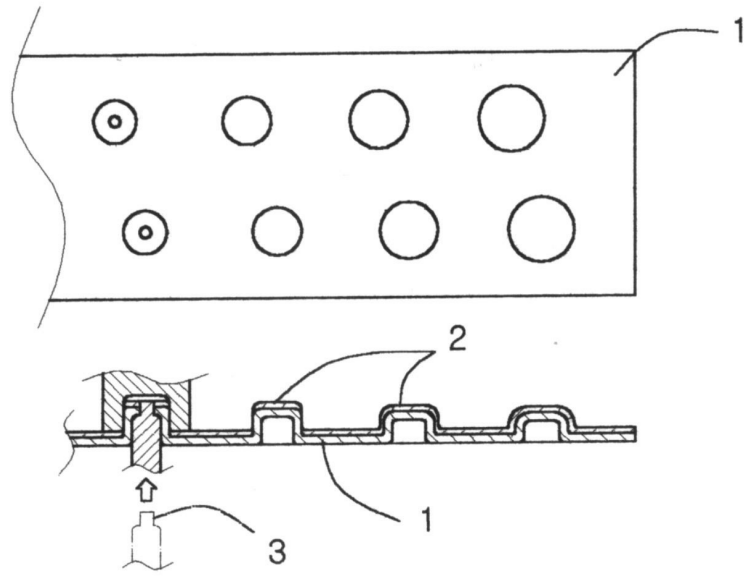

2e

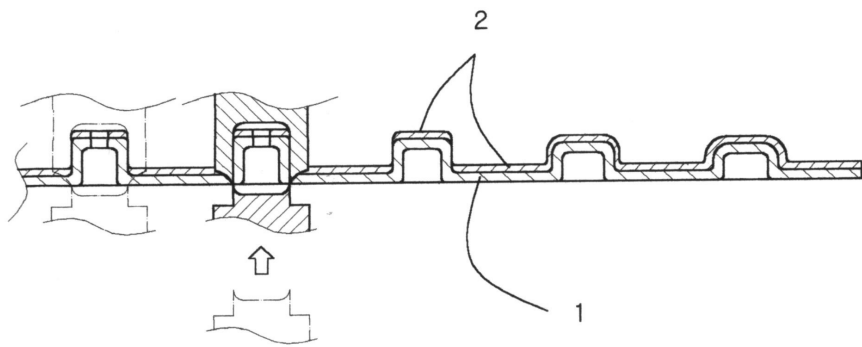

3

