

(No Model.)

2 Sheets—Sheet 1.

J. E. DONALDSON & J. ATHERN. ROOFING TILE.

No. 522,686.

Patented July 10, 1894.

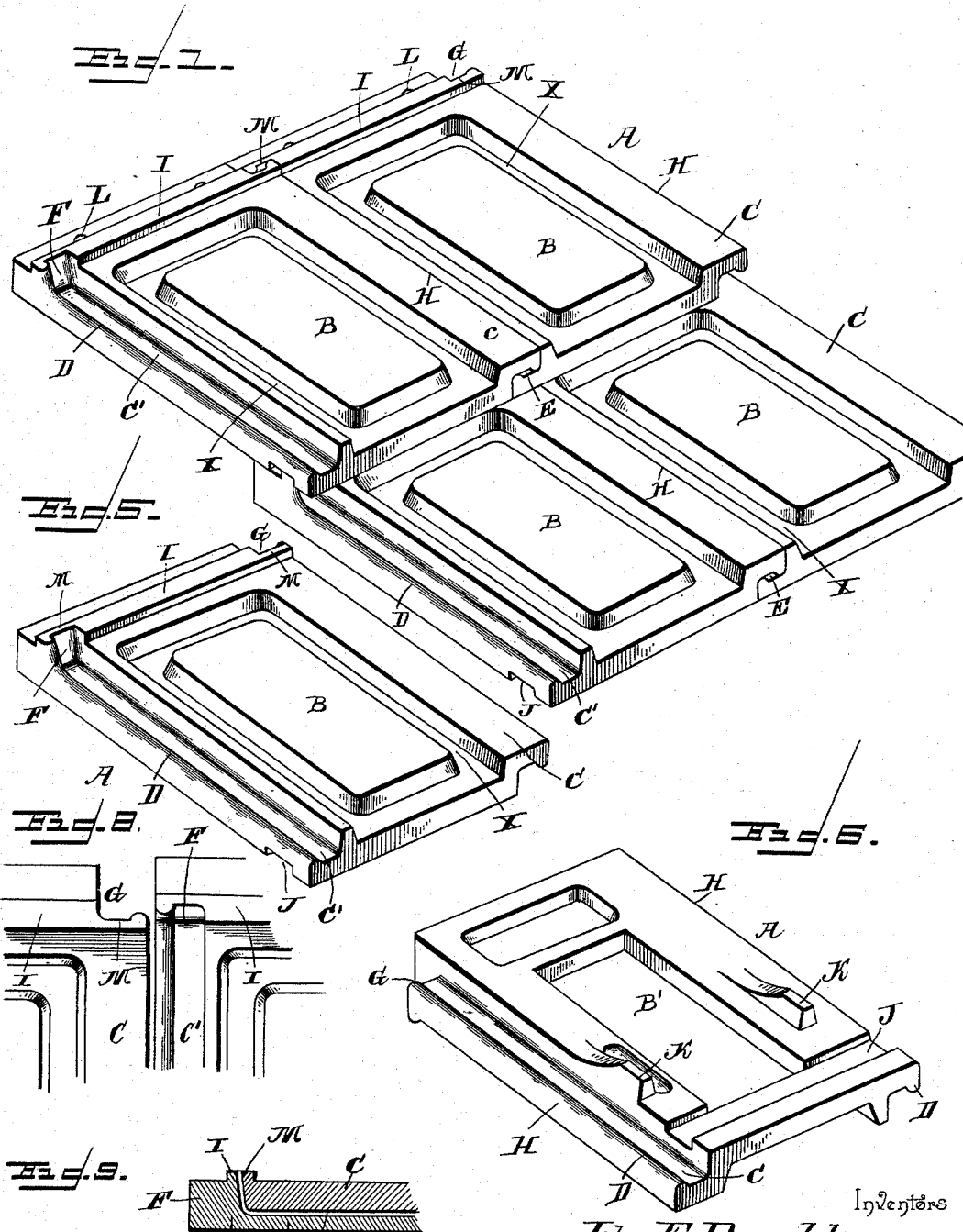

Witnesses
C. N. Stewart
D. P. Hall

By their Attorneys.

Inventors
John E. Donaldson,
John Athern
C. Snow & Co.

J. E. DONALDSON & J. ATHERN.
ROOFING TILE.

No. 522,686.

Patented July 10, 1894.

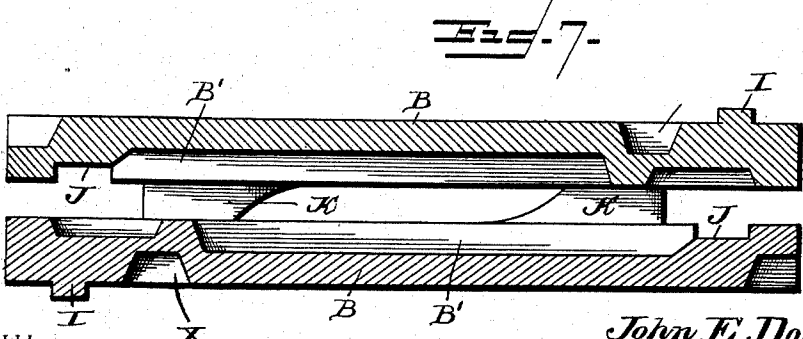
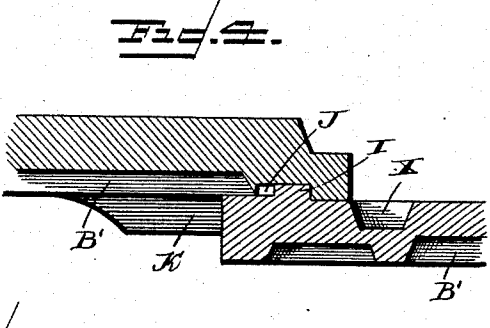
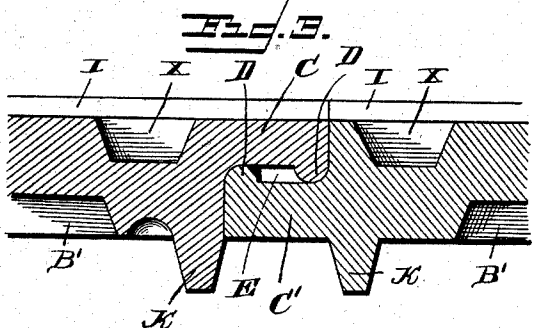
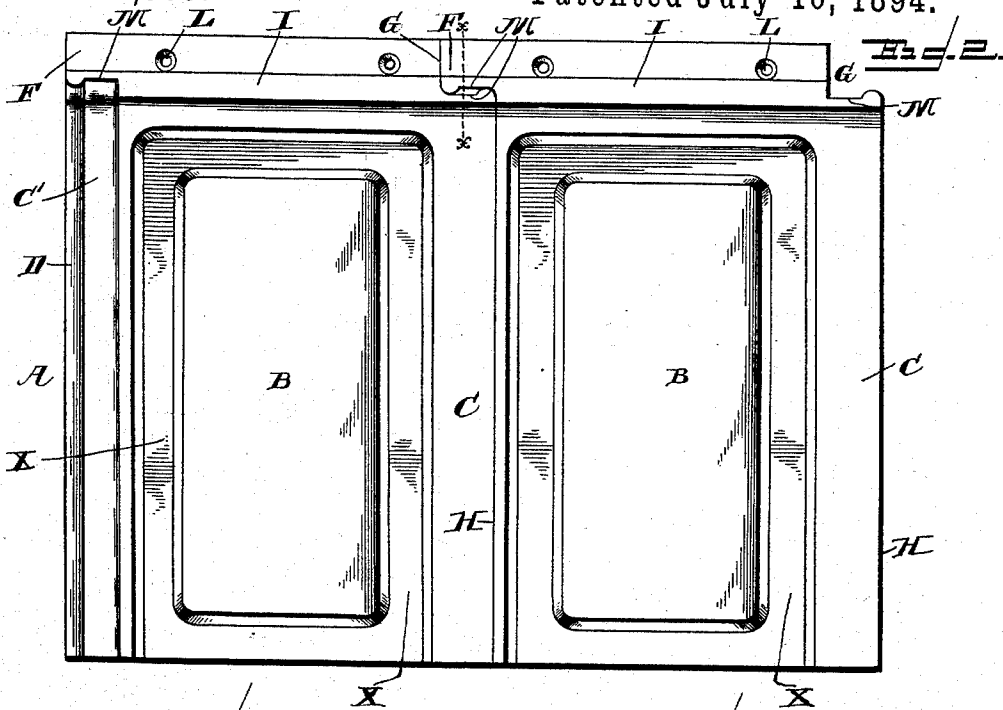

Inventors

John E. Donaldson,

By their Attorneys. John Athern

Witnesses
E. N. Stewart
S. C. Holshaupter

C. A. Snow & Co.

UNITED STATES PATENT OFFICE.

JOHN E. DONALDSON AND JOHN ATHERN, OF MONTEZUMA, INDIANA.

ROOFING-TILE.

SPECIFICATION forming part of Letters Patent No. 522,686, dated July 10, 1894.

Application filed December 8, 1893. Serial No. 493,121. (No model.)

To all whom it may concern:

Be it known that we, JOHN E. DONALDSON and JOHN ATHERN, citizens of the United States, residing at Montezuma, in the county of Parke and State of Indiana, have invented a new and useful Roofing-Tile, of which the following is a specification.

This invention relates to roofing tiles; and it has for its object to effect certain improvements in tiles of that character which are commonly known as clay shingles, and which are generally made of burnt clay or similar material.

To this end the present invention contemplates an improved roofing tile which shall be constructed with especial reference to its strength and durability, while at the same time having novel features of construction whereby the interlocking parts or joints with the other tiles of the roof shall be made with a view to rendering the roofing more perfect and water tight, and such tiles are also intended to be shaped and arranged so as to greatly facilitate the burning thereof.

With these and other objects in view which will readily appear as the nature of the invention is better understood, the same consists in the novel construction, combination and arrangement of parts hereinafter more fully described, illustrated and claimed.

In the drawings:—Figure 1 is a perspective view of a few tiles constructed in accordance with this invention, shown interlocked, and as they appear on a roof. Fig. 2 is a top view of two adjacent tiles in the same row. Fig. 3 is a transverse sectional view of the tiles shown in Fig. 2. Fig. 4 is a detail sectional view showing the connection between the lower end of an upper tile, and the upper ends of the lower tiles overlapped by such upper tile. Figs. 5 and 6 are detail perspective views of a tile showing the top and bottom faces thereof. Fig. 7 is a longitudinal sectional view of two superposed tiles as stacked for burning in the kiln. Fig. 8 is a detail plan view of the interlocking corners of two tiles separated from each other. Fig. 9 is a detail sectional view on the line $x-x$ of Fig. 2.

Referring to the accompanying drawings, A represents a roofing tile constructed in accordance with this invention, and which tile,

together with others of similar construction, is adapted to be placed upon the sheeting of a roof to form the exposed roofing of a building, and to replace the ordinary wood shingles, slates, &c. The tile A, is usually manufactured in sizes of about six and a half inches wide and ten inches long, and in the present invention the top face of the tile is provided with a raised center panel B.

The raised rectangular center panel B, of the tile is formed by leaving a rectangular sunken recess B', in the bottom face of the tile and of a shape corresponding to the rectangular configuration of the raised center panel B.

The panel B, which is raised from the top face of the tile body is surrounded on all sides thereof with the circulating groove X, which groove extends continuously around the upper, lower, and side edges of the panel B, and leads off from the lower edge of the tile, so as to provide for a free running or circulation of water from an upper to a lower tile, to insure a free shedding of the water and the conveyance thereof to the eaves-trough at the lower edge of the roof. The circulating groove X, which entirely surrounds the outer edge of the raised center panel B, not only provides a water-duct for relieving the tile, and the entire roofing formed by such tiles, of the water from rain-storms or the melting of snow, but also provides an air circulating space which greatly assists in the homogeneous drying of all parts of the tile, and particularly the center portion thereof. By this arrangement of a raised center panel with a surrounding circulating groove, the warping or cracking of the tile is practically entirely overcome, inasmuch as the groove X, provides means whereby the air may freely circulate around and come in contact with the entire upper surface of the center of the tile, while the sunken recess or bottom depression B', insures a similar circulation for the air to come in contact with the bottom surface of the center of the tiles, and this construction therefore renders it possible to dry the center of the tile equally with the outer portions thereof.

It is a well known fact with manufacturers of this class of goods, that nearly all clay goods dry much quicker at the outer edges and sides thereof, and for this reason it is

necessary to press the clay more compactly in the center or else run the risk of cracking the outer sides or edges of the article, and for this reason also clays that are more dense than others crack the most. Now by reference to the construction just described it will be obvious that the side edges or walls of the raised panel B, formed by the bottom recess and top groove, will accommodate themselves to the shrinkage of the outer edges or sides of the tile, or in other words, the side edges or walls of the said raised center panel can be pressed in by the outside or edge shrinkage so as to prevent such outer edges of the tile from cracking.

It will thus be seen that the raised center panel forms a very important function in the manufacture of the tile as well as the usefulness thereof as a manufactured article, and, when placed in position on a roof with other tiles, also serves to hold snow or sleet on the tile roof, and thereby prevents such snow or sleet from sliding off of the roof in thaws and endangering gutters and passersby.

The tile A, is further provided at the opposite side edges thereof with the upper and lower projecting lap flanges C, and C', respectively, the upper lap flange C, being projected from the side of the tile body flush with the top face thereof, while the lower lap flange C', is projected from the opposite side of the tile body flush with the bottom face thereof, and both of said lap flanges are provided near their outer edges upon their meeting faces opposite the faces of the tile from which they project, with the longitudinal joint ribs D extending from end to end thereof.

It will be readily understood that the tiles are arranged in rows one above the other in making the roof, and the tiles in each row are arranged side by side with the lap flanges overlapping the corresponding flanges of the adjacent tiles, the lower lap flange C', of one tile, being overlapped by the correspondingly opposite upper lap flange C, of the tile next to that side thereof, and thereby completes a lap joint which permits a slight transverse adjustment of the tiles to assist in making the roof, while at the same time providing a joint which forms a central air space E, enclosed between the joint ribs D, of the meeting flanges, and combining therewith to render the lap joint perfectly water tight, which prevents water from working its way onto the roof frame or sheeting under the tiles.

The lower or bottom lap flanges C', of each tile have their upper ends terminate short of the upper ends of the tile to form a thickened joint-shoulder F, of the same thickness as the tile body and therefore necessarily wider than the width of the flange C', and this joint shoulder F, is adapted to register in the shoulder notch G, formed at the upper end of the flange C, of the adjacent tile. The shoulder notch G, of each tile is formed by cutting away the upper end of the flange C, sufficiently to form a notch which registers

with the shoulder F. By reason of the construction just described, it will be clearly seen that the joint-shoulder F, serves to close in or cover the upper end of the joint formed between the meeting edges H, of each tile, and serves to effectually prevent fine snow or rain from being blown beyond the upper ends of the adjoining tiles, and under the overlapping lower ends of the row of tiles immediately thereabove.

In laying the tiles, the same are usually arranged so as to break joints with each other, and the upper ends of one row of tiles are adapted to be overlapped a sufficient distance by the lower ends of the tiles immediately thereabove, and these upper tiles are adapted to have their lower ends extend up to the upper portions of the circulating grooves C, so as to shed water directly thereinto. The upper ends of each tile are provided upon their top faces with the transverse lock ribs I, and at a corresponding position upon their lower faces with the transverse grooves J, which are adapted to interlock with the ribs I, of the tiles immediately therebelow, and upon their bottom faces, immediately in rear of or above the grooves J, each tile is further provided with the opposite shoulder lugs K, at each side of the sunken recess or bottom depression B' one end of which depression opens into the grooves J to increase the air circulation for drying. These bottom shoulder lugs K, are adapted to engage the upper ends or edges of the tiles immediately below, and serve to act in an auxiliary capacity to the ribs I, and grooves J, so as to properly hold the tiles in position, in addition to the ordinary fasteners passed through the screw or nail holes L, at the upper edges of the tiles.

In the present invention the transverse lock ribs I, are squared and projected a distance above the top face of the tiles, and extend from edge to edge thereof. The said squared transverse lock ribs I, are disposed directly below the screw or nail holes L, and are provided at their opposite extremities with the rabbeted ends M, which register with the corresponding ends of the adjacent tiles, and the rabbets at the ends of the raised ribs I, are of a width equaling the shoulder F, and the notch G, so that when the tiles are laid in position and interlocked, the lock ribs of each row of tiles are also interlocked so that a continuous raised rib is presented and offers a continuous obstruction to rain and fine snow, which cannot pass beyond the aligned ribs I, since there is no joint between these ribs which opens directly under the tiles above. This construction possesses another advantage in the fact that the overlapping registering ends of the ribs I, renders it unnecessary to observe a break joint arrangement of the tiles in laying the same, but on the contrary the tiles may be laid without any consideration to the location of the joints.

The construction of the joint shoulder F, dispenses with the necessity of a supplement-

tal bottom shoulder lug or rib on the tiles to close the upper end of the side lap joint as has been previously done, and therefore greatly facilitates the burning of the tiles.

5 By reference to Fig. 7, of the drawings, it will be seen that, in burning or drying, the bottom faces of the tiles are placed together and the ends reversed, so that the projected shoulder lugs of one tile contact with the bot-
10 tom face of the other tile at an opposite point to the location of its shoulder lugs, and by this arrangement the faces of the tiles are held out of contact with each other, and a free and uninterrupted hot air circulating
15 space is left in the center space between the tiles, so as to insure the free circulation of the hot air to every part of the under face of the tiles, and thereby effect the proper burn-
ing thereof.

20 Many other advantages than those stated arise from the construction of tile herein described, and we will have it understood that changes in the form, proportion and the minor details of construction may be resorted
25 to without departing from the principle or sacrificing any of the advantages of this invention.

30 Having thus described the invention, what is claimed, and desired to be secured by Letters Patent, is—

1. The herein described roofing tiles having raised center panels on the top faces thereof, bottom depressions or recesses B', formed in their bottom faces and extending nearly the
35 entire length thereof, transverse grooves J, in their bottom faces near one end and communicating with said longitudinal depressions or recesses, and spacing shoulder lugs projected from the bottom faces at opposite sides
40 and out of the line of said bottom depressions or recesses, said lugs forming a spacing sup-

port for the tiles when stacked for drying or burning and providing an uninterrupted longitudinal and transverse air circulation through the depressions and grooves of the
45 tiles, substantially as set forth.

2. The herein-described roofing tiles having oppositely disposed lap flanges projected from the upper and lower side edges thereof and extending at their lower ends to the lower
50 edge of the body of the tiles, a shoulder notch G, formed at the upper end of one of said flanges, a thickened joint shoulder F, projected across the upper end of the other one of said flanges and of the same thickness as
55 the body of the tiles, a transverse groove J, formed in their lower faces near their lower ends, and the raised ribs I, said ribs I extending continuously across the top of the tiles at the upper ends thereof and adapted to inter-
60 lock with each other at the meeting joints of the adjacent tiles, substantially as set forth.

3. The herein-described roofing tiles, having opposite upper and lower side lap flanges, a shoulder notch formed at the upper end of
65 one of said flanges, a thickened joint shoulder projected across the upper end of the upper one of said flanges and adapted to register in the adjacent shoulder notch of an ad-
joining tile, and the raised squared ribs ex-
70 tending transversely across the top upper face from edge to edge and provided with rabbeted extremities, substantially as set forth.

In testimony that we claim the foregoing as our own we have hereto affixed our signatures
75 in the presence of two witnesses.

JOHN E. DONALDSON.
JOHN ATHERN.

Witnesses:

WILLIAM J. K. P. JONES,
C. W. CHOWNING.