

(No Model.)

3 Sheets—Sheet 1.

N. B. MILLER.
STREET SWEEPER.

No. 527,757.

Patented Oct. 16, 1894.

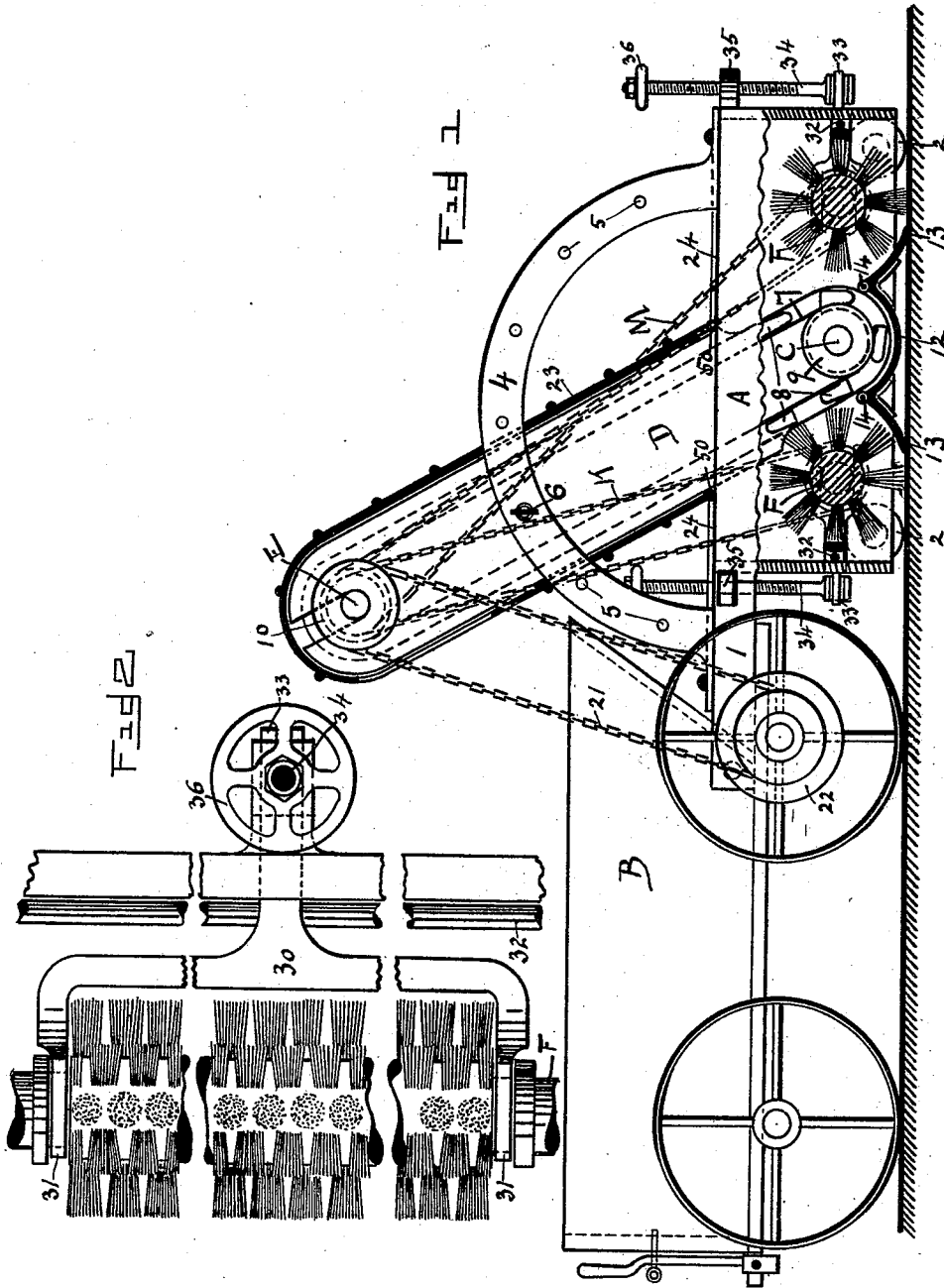

WITNESSES:

M. Schmit
J. W. Sues

INVENTOR

Napoleon B. Miller

BY

J. W. Sues

ATTORNEY.

(No Model.)

3 Sheets—Sheet 2.

N. B. MILLER.
STREET SWEEPER.

No. 527,757.

Patented Oct. 16, 1894.

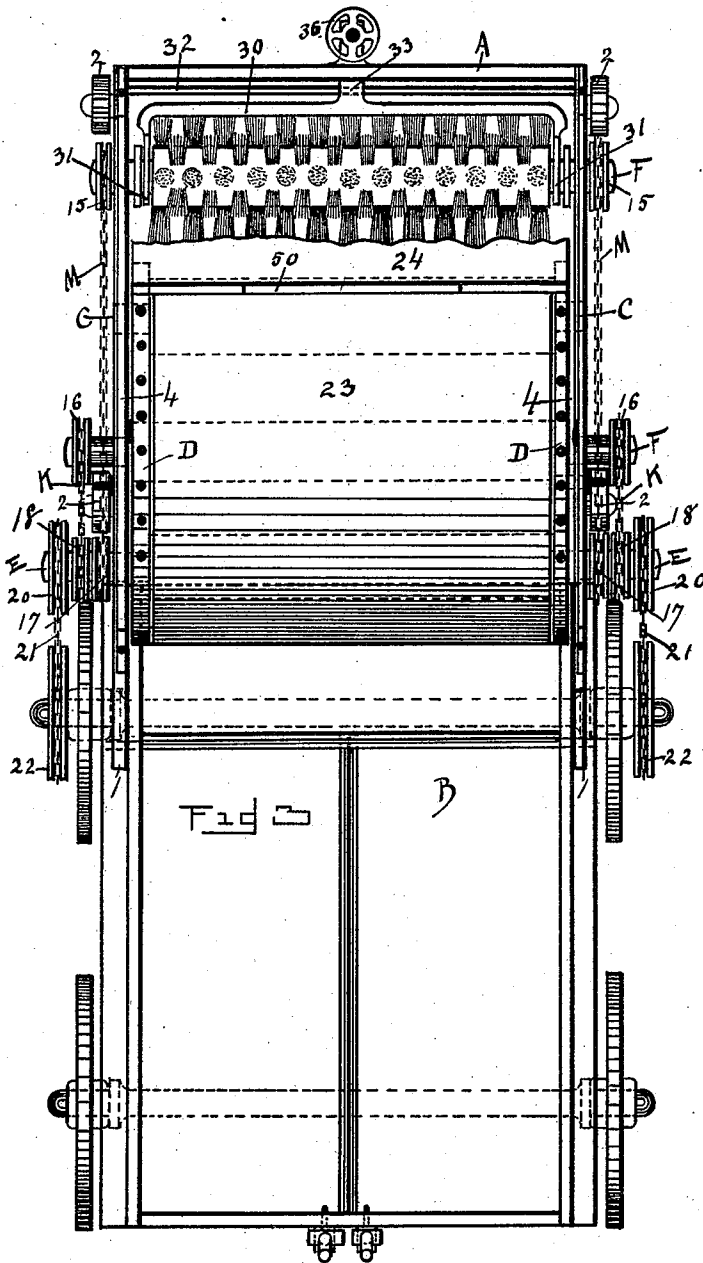

WITNESSES:
N. J. Schmitt
H. V. Sues

INVENTOR
Napoleon B. Miller
BY *H. V. Sues*
ATTORNEY.

(No Model.)

3 Sheets—Sheet 3.

N. B. MILLER.
STREET SWEEPER.

No. 527,757.

Patented Oct. 16, 1894.

FIG 4

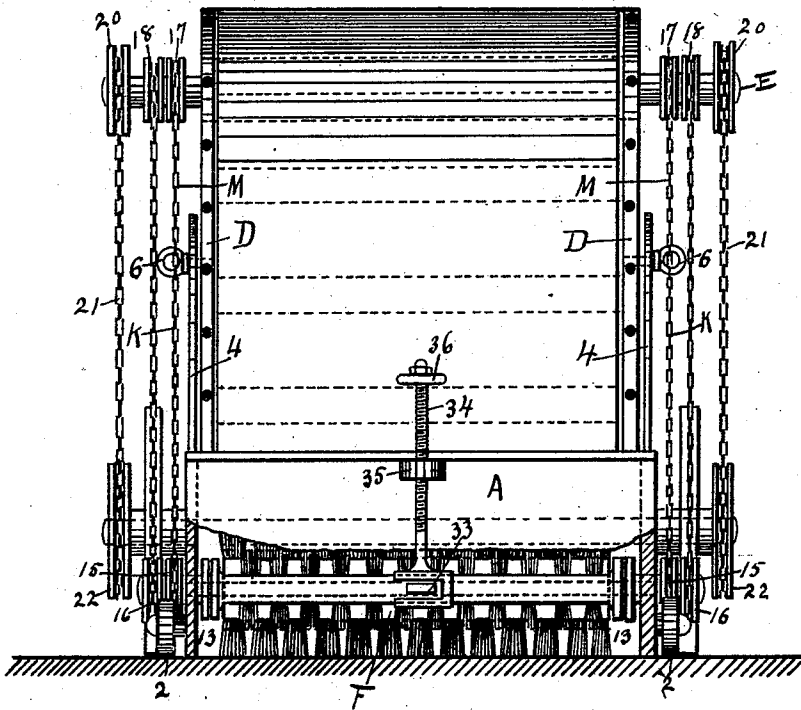

WITNESSES:
M. J. Schmit
J. V. Sues

Napoleon B. Miller
 INVENTOR

BY *C. M. Sues*

ATTORNEY.

UNITED STATES PATENT OFFICE.

NAPOLEON B. MILLER, OF OMAHA, NEBRASKA, ASSIGNOR OF ONE-HALF TO
FREDERICK MOHLE, OF SAME PLACE.

STREET-SWEEPER.

SPECIFICATION forming part of Letters Patent No. 527,757, dated October 16, 1894.

Application filed June 19, 1893. Renewed September 17, 1894. Serial No. 523,235. (No model.)

To all whom it may concern:

Be it known that I, NAPOLEON B. MILLER, of Omaha, in the county of Douglas and State of Nebraska, have invented certain useful Improvements in Street-Sweepers; and I do hereby declare that the following is a full, clear, and exact description of the invention, such as will enable others skilled in the art to which it appertains to make and use the same, reference being had to the accompanying drawings, which form a part of this specification.

This invention has relation to a new and novel improvement in street sweepers, the object being to provide a sweeper that shall be simple of construction, readily operated and adapted to be detachably secured to any ordinary wagon.

In the accompanying drawings, Figure 1 shows a side elevation, partly in section, of a sweeper embodying my invention. Fig. 2 is a broken top view of the broom elevating mechanism. Fig. 3 is a top view of Fig. 1; while Fig. 4 shows a rear view of my improved street sweeper.

A represents a suitable broom housing, which is provided with two extending sills 1, by means of which this housing is secured to the body of any ordinary wagon B. This housing A is supported by means of four wheels, marked 2. Transversely mounted within the housing A, is the main operating shaft C, which projects beyond both sides of the housing. Two side bars D, D, are movably mounted upon this shaft C which at their upper ends are provided with the shaft E which receives rotary motion from a source hereinafter set forth. Secured to the deck of the housing are the two semi-circular braces 4, preferably of iron, provided with a number of screw openings 5, through which a hand screw 6 is adapted to pass and work into the movable bars D, as shown in Fig. 1. The shafts, C, and E, are provided with drums, 9, and 10, respectively, around which passes an endless apron, 7, provided with buckets, 8.

Below the shaft C, I have provided a semi-circular trough 12, having the extending scoop portions 13, 13. This trough 12 is supported by means of two bolts 14, passing

through the side of the broom housing which secure this trough. The apron, in carrying the buckets 8 around the shafts is adapted to sweep the buckets through this trough 12 and so scoop and gather any dirt that may have collected in this trough 12. Mounted in slots upon each side of said shafts C are the two similar broom shafts F, F, which project beyond the housing A, upon each side and are provided with the pulleys 15 and 16. Mounted upon the shaft E, which projects beyond the supporting bars D, are the grooved pulleys 17 and 18, which are provided with chains which are adapted to work over the pulleys 15 and 16 of the broom shafts F, and so convey a rotary movement to these brooms. These brooms are adapted to work in opposite directions and sweep the dirt and dust upon the shields 13 and finally into the trough 12, from whence the same is carried by the buckets 8 upward and deposited into the wagon to which the device is attached.

20 represents the flanged pulleys which are secured to the upper shaft E and provided with chains 21 which are adapted to pass over grooved pulleys 22, which pulleys are detachably secured to the hubs or spokes of the rear wagon wheels of the wagon B, and it is from this power of the rear wagon wheels that the brooms, as well as the elevator, are operated. The elevator is provided with a sheet metal dust cap 23, which extends a suitable distance beyond the broom housing. The housing has two sliding deck portions 24, which are pivotally secured to the dust hood 23. Now, if it is desired to give this elevator any different adjustment, it is simply necessary to remove the screw 6 and carry the elevator into the desired position, when the screw is again inserted and the elevator is operated in its new position. The brooms are given vertical adjustment by means of the bifurcated bars 30, which are provided with the shoes 31 at each end and through which the shafts F, F pass. Each of these bars 30 is pivotally supported by means of a transverse bar 32, which supports the bar and projects in the rear in the form of a stem 33. This stem 33 is encompassed by the threaded foot rod 34, which works through a hub 35, secured to the hous-

ing of the wagon. Now, as this screw 34 is either raised or lowered by means of the hand-wheel 36, the brooms F are, also, lowered or raised respectively.

5 The device is exceedingly simple of construction and readily operated.

As the dirt cart B is carried through the streets to be cleaned, the brooms F are revolved by means of their respective chain
10 connections with the shaft E and sweep the dust first upon the shields 13 and then into the trough 12, from whence it is carried upward and deposited in the wagon.

The device is light and the working parts
15 are readily adjustable.

Having thus described my said invention, what I claim as new, and desire to secure by United States Letters Patent, is—

1. The combination with a suitable housing,
20 mounted upon wheels and provided with projecting sills by means of which said housing can be attached to any suitable dirt wagon of two transverse broom shafts each adjustably held within said housing by means of a
25 bifurcated bar supporting the ends of said broom shaft, said bar being pivotally secured within the broom housing and having an extending stem and an adjusting screw secured within suitable lugs of the broom housing
30 and adapted to raise and lower said stem all substantially as and for the purpose set forth.

2. The combination with a suitable broom

housing, of two brooms held within the ends
35 of two bifurcated bars which are pivotally mounted within said housing and provided, each, with an extending stem, screws adapted to act against said stems, a dust collecting scoop mounted between said brooms, having a
40 central depression and two extending wings extending partially below said brooms, an endless elevator mounted above said dust collecting scoop, and means for operating the brooms and elevator, all substantially as and
45 for the purpose set forth.

3. The combination with the wheeled housing, A, of the transverse main operating shaft, C, the bars, D D, movably secured to said shaft, and provided at their upper end with the shaft, E, the semicircular braces, 4—4,
50 adapted to adjustably secure said bars, D—D, an endless carrier, 7, passing over said shafts, C and E, the trough, 12, secured within said housing and below said shaft, C, belt connections passing from said shaft, E, to a suitable
55 running gear, in combination with the rotary brooms, F F, and bolt connections between the shaft, E, and said brooms all substantially as and for the purpose set forth.

In testimony whereof I affix my signature in
60 presence of two witnesses.

NAPOLEON B. MILLER.

Witnesses:

O. CHAT. REDICK,
H. D. HICKS.