

Feb. 4, 1930.

R. L. BROWN

1,745,599

CONE SPEAKER

Filed Dec. 10, 1926

2 Sheets-Sheet 1

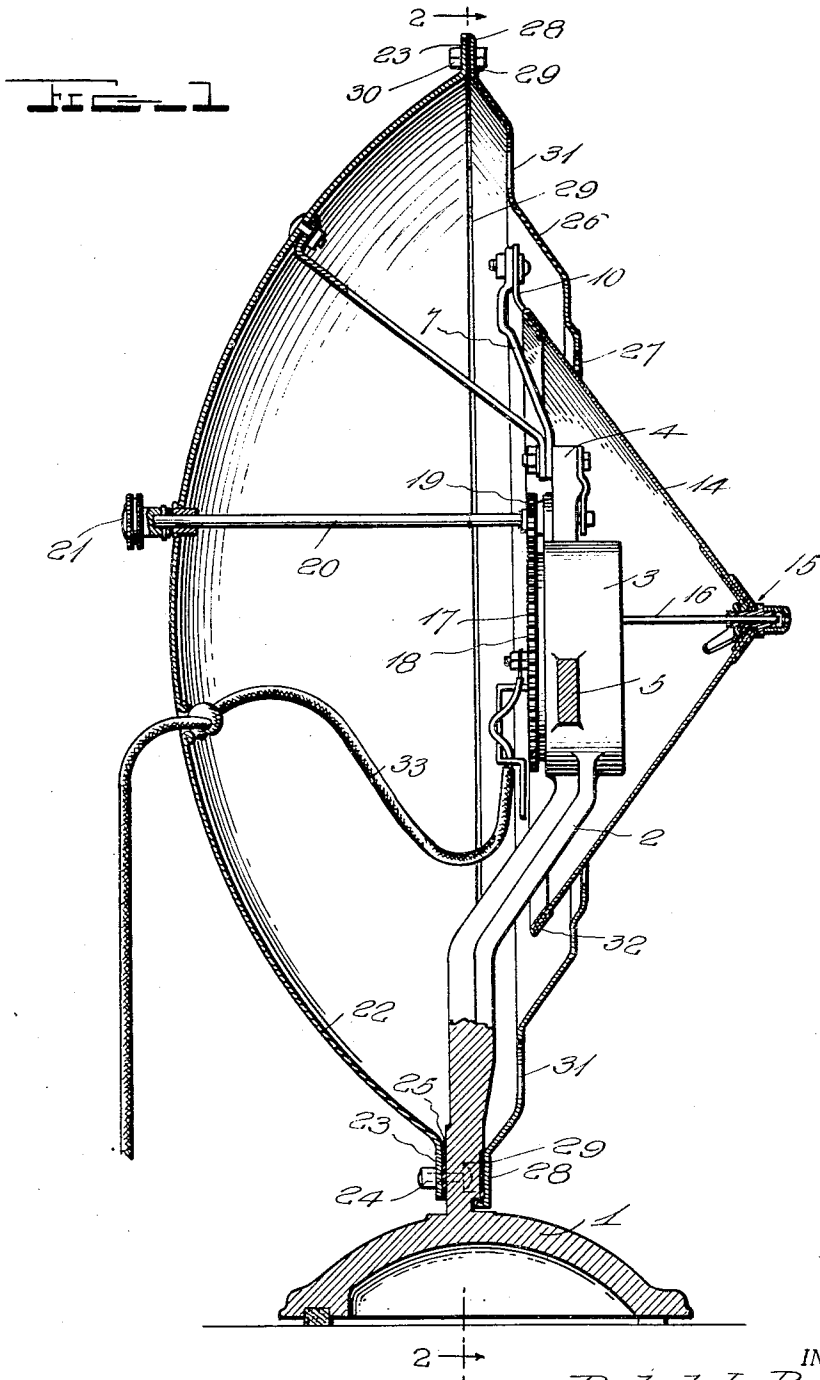

INVENTOR.
Ralph L. Brown,
BY *John O. Brody*
ATTORNEY

UNITED STATES PATENT OFFICE

RALPH L. BROWN, OF NEWARK, NEW JERSEY, ASSIGNOR TO BRANDES LABORATORIES, INC., OF NEWARK, NEW JERSEY, A CORPORATION OF NEW JERSEY

CONE SPEAKER

Application filed December 10, 1926. Serial No. 153,972.

My invention relates broadly to electromagnetic sound reproducers and more particularly to a construction of sound reproducer employing a free edge cone shaped sound reproducing diaphragm.

One of the objects of my invention is to provide a construction of sound reproducer which is efficient in operation for the reproduction of sound over a broad band of tone frequencies where a sound reproducing diaphragm substantially conical in shape is employed the diaphragm having a free edge and being supported at its apex.

Another object of my invention is to provide an electromagnetic sound reproducer including a conical shaped sound reproducing diaphragm located in front of a substantially parabolic sound reflecting surface by which sound emanating from the rear of the conical shaped sound reproducing diaphragm is reflected outwardly in phase with the sound waves emanating from the front of the sound reproducing diaphragm.

My invention will be more clearly understood from the specification hereinafter following by reference to the accompanying drawings wherein:

Fig. 1 is a vertical cross-sectional view taken through the sound reproducer of my invention; Fig. 2 is a lateral cross-sectional view taken through the electromagnetic sound reproducer on line 2—2 of Fig. 1; Fig. 3 is a plan view of the cone shaped sound reproducing diaphragm employed in the electromagnetic sound reproducer of my invention; and Fig. 4 is a cross-sectional view taken through the sound reproducing diaphragm employed in the loud speaker of my invention.

Referring to the drawings in more detail, reference character 1 represents a stand on which the loud speaker of my invention is mounted. A member 2 extends upwardly from the base 1 and is provided with a housing 3 at the upper extremity thereof. Lug members 4, 5 and 6 protrude from the housing 3 and provide supports for the brace members 7, 8 and 9, which at the outer extremities thereof carry flexible strap members 10, 11 and 12, which connect with the

free edge of the conical shaped sound reproducing diaphragm 14. The sound reproducing diaphragm 14 is practically supported from its apex 15 on a driving rod 16 which connects to the electromagnetic driving mechanism within the housing 3 and which carries the mass of the cone although the actual centering of the cone within the reflector is obtained by means of members 10, 11 and 12. The electromagnetic system of the electromagnetic driver is carried by a rotatable plate member 17, which is provided with peripheral teeth 18 which are engaged by pinion 19 driven under the action of shaft 20 from control knob 21 for moving the electromagnetic system carried by plate 17 to different positions with respect to the armature of the electromagnetic operating mechanism. A sound reflector 22 which is substantially parabolic in shape is supported adjacent the rear of the sound reproducing diaphragm 14. The reflector 22 is suitably pressed from metallic material with an annular flange 23 formed thereon. The flange 23 abuts against one side of the supporting member 2 which extends from the base member 1. Suitable bolt members 24 are provided for fixing sound reflector 22 in position with respect to the base 1. A gasket 25 is fitted between the flange 23 and the support 2. The reflecting surface formed by the reflector 22 is effectively turned inwardly at the front of the sound reproducer by positioning the annular reflecting member 26 in telescopic relation to the sound reproducing diaphragm 14. The reflecting surface 26 is centrally apertured at 27 enabling the cone shaped sound reproducing diaphragm 14 to protrude from the sound reflecting surfaces. The reflector 26 is provided with an annular flange 28 secured at its peripheral edge with respect to flange 23 with a sealed joint comprising the gasket 29, which is tightly retained in place by a plurality of bolt members 30 at spaced intervals around the peripheral edge of the sound reflecting surfaces. The reflecting surface 26 is apertured at a plurality of points around its periphery as represented at 31 in such manner that sound emanating from the rear of

the conical shaped diaphragm 14 strikes the parabolic reflecting surface 22 and is radiated outwardly through apertures 31 for effectively increasing the volume of sound radiating from the outer surface of the cone 14.

The conical shaped sound reproducing diaphragm 14 has its free edge protected from mechanical stresses by means of the beading 32 from which the tongues 10, 11 and 12 project for centering the conical shaped diaphragm with respect to the sound reflecting surfaces. A flexible connecting cord 33 extends from the terminals of the electromagnetic driving mechanism through the sound reflecting surface 22 to a position outside of the loud speaker. The electromagnetic driving mechanism is adjusted for actuating the diaphragm to selected conditions for the particular selection which is to be reproduced. The combined effect of the sound delivered from the rear and front surfaces of the sound reproducing diaphragm is such as to substantially increase the volume of the program being received.

The construction of the loud speaker of my invention has been found to be particularly effective for reproducing both the low and high notes within the musical ranges encountered in broadcast reception.

While I have described my invention in certain preferred embodiments, I desire that it be understood that modifications may be made and that no limitations upon my invention are intended other than are imposed by the scope of the appended claims.

What I claim as new and desire to secure by Letters Patent of the United States is as follows:

1. A sound reproducer comprising an actuating member, a support for said member, a plurality of brace members extending from said support, a conical shaped sound reproducing diaphragm, independent flexible tabs extending from each of said brace members and connected at spaced intervals with the periphery of said conical shaped sound reproducing diaphragm and a sound reflector positioned adjacent said diaphragm.

2. A sound reproducer comprising a support, an actuating member carried by said support, a free edge cone shaped sound reproducing diaphragm supported at its apex by said actuating member, and a parabolic sound reflector positioned adjacent one side of said sound reproducing diaphragm.

3. In a sound reproducer a supporting member, an actuating member carried by said supporting member, a free edge cone shaped sound reproducing diaphragm supported at its apex by said actuating member, and a substantially parabolic shaped sound reflector forming a surrounding closure for said sound reproducing diaphragm.

4. A sound reproducer comprising a supporting member, an actuating driver carried

by said supporting member, a free edge conical shaped sound reproducing diaphragm, said diaphragm being supported at its apex by said driver and a substantially parabolic sound reflector positioned adjacent the base of said conical shaped sound reproducing diaphragm and having a portion thereof extending over the front of said sound reproducing diaphragm and apertured at a plurality of places for the radiation of sound reflected from said parabolic sound reflector.

5. A sound reproducer comprising a supporting member, an actuating member carried by said supporting member, a substantially free edge conical shaped sound reproducing diaphragm supported at its apex by said actuating member, a substantially parabolic sound reflector positioned adjacent one side of said sound reproducing diaphragm and having a diameter larger than the base of said diaphragm, a plate member telescopically positioned over said conical shaped sound reproducing diaphragm and connected to the periphery of said parabolic sound reflector, said plate member being apertured in a plurality of places for permitting sound reflected from one side of said diaphragm to be directed outwardly for reinforcing the sound delivered by the opposite side of said sound reproducing diaphragm.

6. A sound reproducer comprising a supporting member, an actuating driver carried by said supporting member, a free edge conical shaped sound reproducing diaphragm supported from its apex by said actuating driver and a stiffening bead formed around the free edge of said sound reproducing diaphragm.

7. A sound reproducer comprising a supporting member, an actuating driver carried by said supporting member, a free edge conical shaped sound reproducing diaphragm supported from its apex by said actuating driver, a stiffening bead formed around the peripheral edge of said conical shaped sound reproducing diaphragm, a plurality of independent flexible tabs extending from said stiffening bead, and brace members extending from said supporting member and individually connected to said flexible tabs for centering said diaphragm with respect to said actuating driver.

In testimony whereof I affix my signature.

RALPH L. BROWN.