

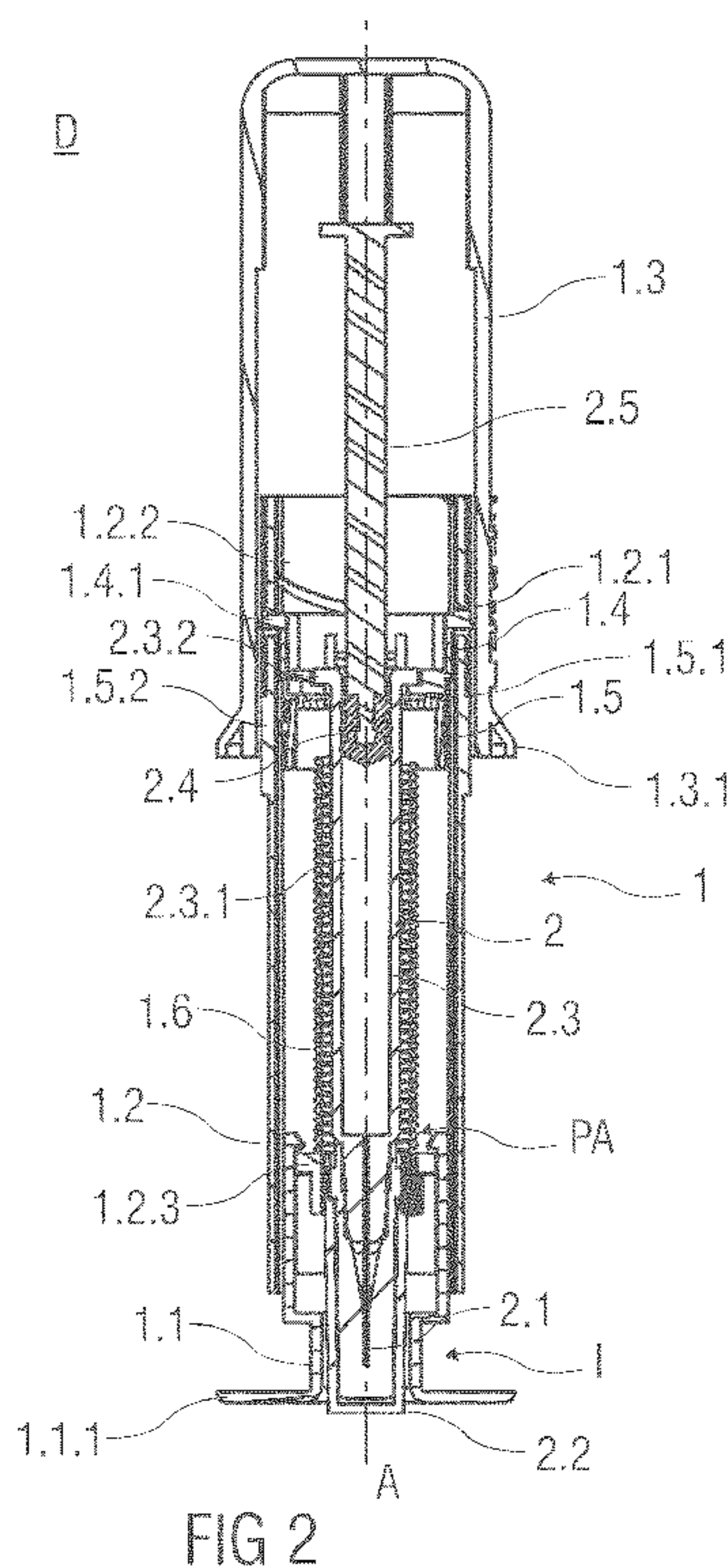

(86) Date de dépôt PCT/PCT Filing Date: 2011/12/30  
 (87) Date publication PCT/PCT Publication Date: 2012/07/12  
 (85) Entrée phase nationale/National Entry: 2013/06/25  
 (86) N° demande PCT/PCT Application No.: EP 2011/074275  
 (87) N° publication PCT/PCT Publication No.: 2012/093070  
 (30) Priorité/Priority: 2011/01/04 (EP11150077.3)

(51) Cl.Int./Int.Cl. *A61M 5/20* (2006.01),  
*A61M 5/32* (2006.01)  
 (71) Demandeur/Applicant:  
SANOFI-AVENTIS DEUTSCHLAND GMBH, DE  
 (72) Inventeurs/Inventors:  
ROBERTS, GARETH, GB;  
EKMAN, MATTHEW, GB  
 (74) Agent: BERESKIN & PARR LLP/S.E.N.C.R.L.,S.R.L.

(54) Titre : DISPOSITIF DE SURETE POUR UNE SERINGUE PRE-REPLIEE, ET DISPOSITIF D'INJECTION  
 (54) Title: A SAFETY DEVICE FOR A PRE-FILLED SYRINGE AND AN INJECTION DEVICE



(57) **Abrégé/Abstract:**

A safety device(1) for a pre-filled syringe (2) is proposed that comprises -a hollow support body (1.2) with a helical groove (1.2.2) formed into an inner surface thereof, -a mounting collar (1.4) for mounting the pre-filled syringe (2) to the support body (1.2), -a spinning collar (1.5) with a helical tongue (1.5.2) formed to an outer surface thereof and -a torsion spring(1.6). The helical groove (1.2.2) accommodates the helical tongue (1.5.2). Upon release, the torsion spring (1.6) is capable of exerting a torque upon the spinning collar (1.5) which causes the spinning collar(1.5) to rotate within the support body(1.2). The engagement of the helical groove (1.2.2) and the helical tongue (1.5.2) redirects the rotational movement of the spinning collar (1.5) to a translatory movement that moves the mounting collar (1.4) in a proximal direction.



(12) INTERNATIONAL APPLICATION PUBLISHED UNDER THE PATENT COOPERATION TREATY (PCT)

(19) World Intellectual Property  
Organization  
International Bureau(10) International Publication Number  
**WO 2012/093070 A1**(43) International Publication Date  
12 July 2012 (12.07.2012)

(51) International Patent Classification:

A61M 5/20 (2006.01) A61M 5/32 (2006.01)

(21) International Application Number:

PCT/EP2011/074275

(22) International Filing Date:

30 December 2011 (30.12.2011)

(25) Filing Language:

English

(26) Publication Language:

English

(30) Priority Data:

11150077.3 4 January 2011 (04.01.2011) EP

(71) Applicant (for all designated States except US): **SANOFI-AVENTIS DEUTSCHLAND GMBH** [DE/DE]; Sanofi-Aventis Deutschland GmbH, Brüningstraße 50, 65929 Frankfurt (DE).

(72) Inventors; and

(75) Inventors/Applicants (for US only): **ROBERTS, Gareth** [GB/GB]; Glendale, Pen-y-cae Road, Ruabon, WrexhamLL14 6EB (GB). **EKMAN, Matthew** [GB/GB]; 59 Ecton Avenue, Cheshire, Macclesfield Cheshire SK10 1RD (GB).

(81) Designated States (unless otherwise indicated, for every kind of national protection available): AE, AG, AL, AM, AO, AT, AU, AZ, BA, BB, BG, BH, BR, BW, BY, BZ, CA, CH, CL, CN, CO, CR, CU, CZ, DE, DK, DM, DO, DZ, EC, EE, EG, ES, FI, GB, GD, GE, GH, GM, GT, HN, HR, HU, ID, IL, IN, IS, JP, KE, KG, KM, KN, KP, KR, KZ, LA, LC, LK, LR, LS, LT, LU, LY, MA, MD, ME, MG, MK, MN, MW, MX, MY, MZ, NA, NG, NI, NO, NZ, OM, PE, PG, PH, PL, PT, QA, RO, RS, RU, RW, SC, SD, SE, SG, SK, SL, SM, ST, SV, SY, TH, TJ, TM, TN, TR, TT, TZ, UA, UG, US, UZ, VC, VN, ZA, ZM, ZW.

(84) Designated States (unless otherwise indicated, for every kind of regional protection available): ARIPO (BW, GH, GM, KE, LR, LS, MW, MZ, NA, RW, SD, SL, SZ, TZ, UG, ZM, ZW), Eurasian (AM, AZ, BY, KG, KZ, MD, RU, TJ, TM), European (AL, AT, BE, BG, CH, CY, CZ, DE, DK, EE, ES, FI, FR, GB, GR, HR, HU, IE, IS, IT, LT, LU, LV, MC, MK, MT, NL, NO, PL, PT, RO, RS, SE, SI, SK,

[Continued on next page]

(54) Title: A SAFETY DEVICE FOR A PRE-FILLED SYRINGE AND AN INJECTION DEVICE

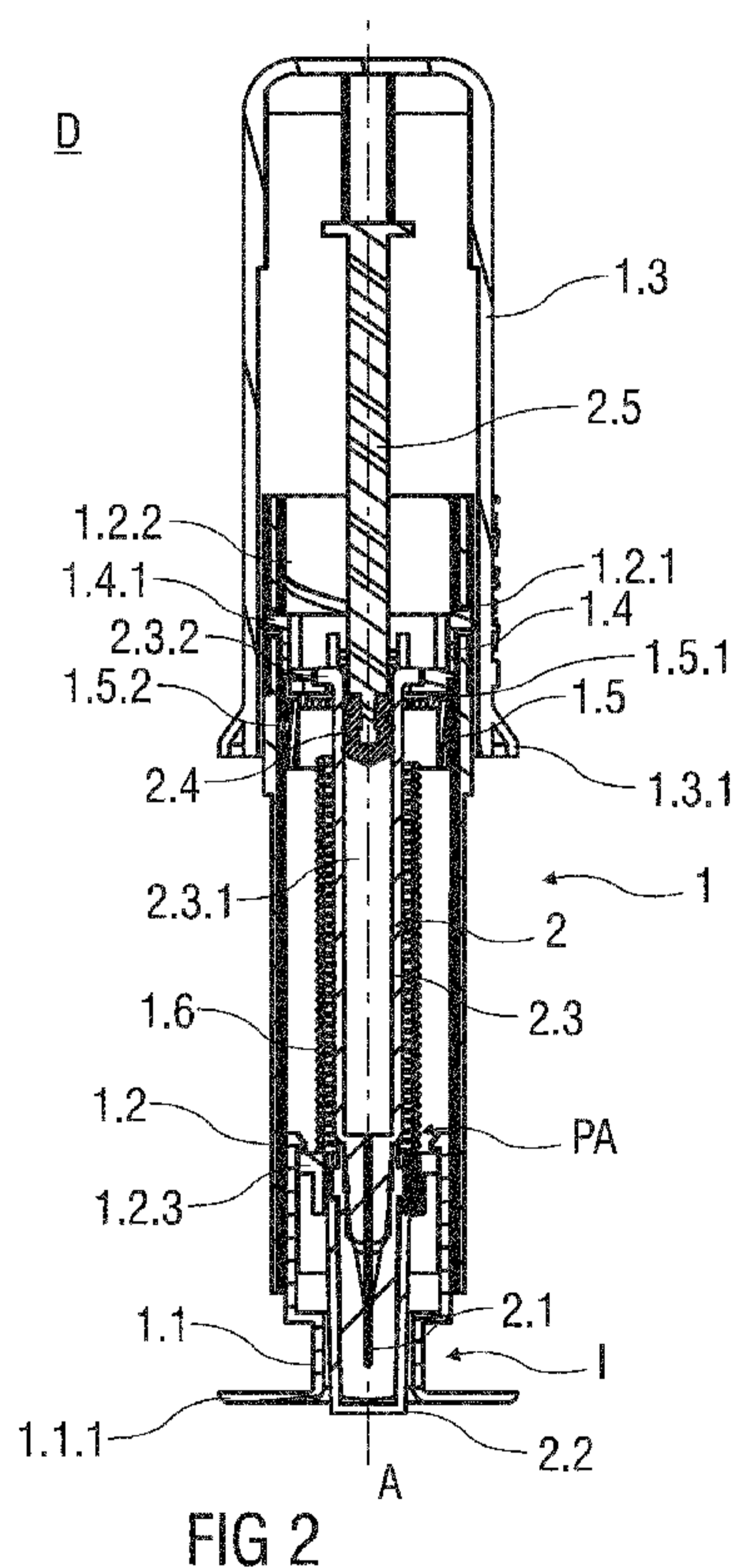

(57) Abstract: A safety device(1) for a pre-filled syringe (2) is proposed that comprises -a hollow support body (1.2) with a helical groove (1.2.2) formed into an inner surface thereof, -a mounting collar (1.4) for mounting the pre-filled syringe (2) to the support body (1.2), -a spinning collar (1.5) with a helical tongue (1.5.2) formed to an outer surface thereof and -a torsion spring(1.6). The helical groove (1.2.2) accommodates the helical tongue (1.5.2). Upon release, the torsion spring (1.6) is capable of exerting a torque upon the spinning collar (1.5) which causes the spinning collar(1.5) to rotate within the support body(1.2). The engagement of the helical groove (1.2.2) and the helical tongue (1.5.2) redirects the rotational movement of the spinning collar (1.5) to a translatory movement that moves the mounting collar (1.4) in a proximal direction.

**WO 2012/093070 A1**



---

SM, TR), OAPI (BF, BJ, CF, CG, CI, CM, GA, GN, GQ, GW, ML, MR, NE, SN, TD, TG). **Published:**

— *with international search report (Art. 21(3))*

**Declarations under Rule 4.17:**

— *of inventorship (Rule 4.17(iv))*

A safety device for a pre-filled syringe and an injection device

#### Technical Field

5 The present invention relates to safety devices that provide needle safety and more particularly to safety devices for pre-filled syringes. The safety device is adapted to avoid accidental needle pricks and needle injuries before, during and after an injection of a medication or drug contained in the pre-filled syringe. In particular, the safety device provides needle safety for a subcutaneous self-administrated injection or for an  
10 injection administered by a health-care professional. The present invention further relates to injection devices comprising a pre-filled syringe.

#### Background of the Invention

15 Pre-filled syringes that are filled with a selected dosage of a medication are well known injection devices for administering the medication to a patient. Safety devices for covering a needle of a pre-filled syringe before and after use are also well known. Typically, these devices comprise a needle shroud that is either manually moved or  
20 moved by the action of a relaxing spring to surround the needle.

A different type of safety device known in the state of the art achieves the object of providing needle safety by arranging the pre-filled syringe movable relative to a body, where the pre-filled syringe is retracted into the body after the injection.  
25

#### Summary of the Invention

It is an object of the present invention to provide an improved safety device for a pre-  
30 filled syringe.

It is a further object of the invention to provide an improved injection device comprising a pre-filled syringe that is safe to handle and in particular prevents accidental needle stick injuries.

- 5 The object is achieved by a safety device according to claim 1 and by an injection device according to claim 9.

Preferred embodiments of the invention are given in the dependent claims.

- 10 In the context of this specification, the terms distal and proximal are defined from the point of view of a person performing an injection. Consequently, a distal direction refers to a direction pointing towards the body of a patient receiving an injection and a distal end defines an end of an element that is directed towards the body of the patient. Respectively, the proximal end of an element or the proximal direction is directed away  
15 from the body of the patient receiving the injection and opposite to the distal end or distal direction.

According to the invention, a safety device for a pre-filled syringe comprises

- a hollow support body with a helical groove formed into an inner surface thereof,
- 20 - a mounting collar for mounting the pre-filled syringe to the support body,
- a spinning collar with a helical tongue formed to an outer surface thereof and
- a torsion spring.

The helical groove accommodates the helical tongue. Upon release, the torsion spring is capable of exerting a torque upon the spinning collar which causes the spinning collar  
25 to rotate within the support body. The engagement of the helical groove and the helical tongue redirects the rotational movement of the spinning collar to a translatory movement that moves the mounting collar in a proximal direction.

The safety device provides needle safety for an injection needle attached to a distal end  
30 of the pre-filled syringe after an injection is completed. The pre-filled syringe may be attached to the mounting collar, so that the proximal movement of the mounting collar safely retracts the pre-filled syringe to a retracted position. In the retracted position, the

used injection needle is surrounded by the support body to prevent accidental needle stick injuries. In particular, infections resulting from needle stick injuries with contaminated injection needles are thus avoided.

5 The torsion spring is arranged within the support body in a pre-tensioned state. The torsion spring provides a reliable energy source for the retraction mechanism providing needle safety after the injection is completed. Upon the release of the mounting collar, the torsion spring exerts a torque upon the spinning collar which in turn starts to rotate within the support body.

10

The spinning collar may comprise a bearing surface that bears against the mounting collar in the proximal direction, so that the spinning collar may push the mounting collar and the pre-filled syringe attached thereto in the proximal direction. The bearing surface is essentially ring-shaped, so that an area that abuts the mounting collar is reduced.

15 This helps to reduce unintentional friction between the mounting collar and the spinning collar. As the spinning collar rotates around a central axis of the safety device while the mounting collar and the pre-filled syringe attached thereto are retracted, occurring high friction between the mounting collar and the spinning collar may cause one of these parts to get stuck within the support body and/or a failure of the retraction mechanism of  
20 the safety device. The bearing surface of reduced area thus ensures a reliable use of the safety device.

According to a possible embodiment of the invention, the mounting collar is releasably mounted to the support body by a catch protruding through an aperture formed into the  
25 support body. The mounting collar is thus releasably mounted to the support body by particularly simple means that efficiently prevent an early release of the mounting collar.

An outer body may be slidably arranged with respect to the support body, wherein the outer body substantially receives the support body at the end of an injection stroke  
30 delivering a dose of medication beneath the skin of a patient. The catch protruding through the aperture of the support body is inwardly deflected by the outer body to release the mounting collar at the end of the injection stroke. A further interaction of the

user performing the injection is not necessary to release the mounting collar. The mounting collar is automatically released upon completion of the injection stroke.

5 According to another possible embodiment of the invention, the catch latches to a distal end of the support body to lock the mounting collar in the retracted position. The injection needle is surrounded and protected by the support body in the retracted position to avoid needle stick injuries. The catch locks the mounting collar and the pre-filled syringe comprising the injection needle in the retracted position and thus prevents a re-exposure of the injection needle.

10 According to yet another possible embodiment of the invention, a needle shroud is slidably arranged with respect to the support body. A first flange adapted to be pressed against a skin surface is formed to a distal end of the needle shroud. During the injection, the first flange rests on the skin surface. The needle shroud may be made  
15 from an opaque plastics material to hide the injection needle from the view of a patient throughout the injection. This may help to ease a possible fear of needles of the patient.

20 Alternatively, the needle shroud may be made from a transparent plastics material that allows the user to visually confirm the correct placement of the injection needle. This alternative embodiment is thus particularly suited for intravascular injections.

According to yet another possible embodiment of the invention, a second flange adapted to be pressed against skin surface is formed to a distal end of the support body. A needle shroud is omitted. Thus, the safety device of this embodiment only comprises  
25 a few parts preferably made from a plastics material. The safety device may thus be mass-produced at low costs.

According to the invention, an injection device comprises a safety device and a pre-filled syringe. An injection needle is attached to a distal end of the pre-filled syringe. The  
30 safety device comprises

- a hollow support body with a helical groove formed into an inner surface thereof,
- a mounting collar for mounting the pre-filled syringe to the support body,

- a spinning collar with a helical tongue formed to an outer surface thereof and
- a torsion spring.

The helical groove accommodates the helical tongue. Upon release, the torsion spring is capable of exerting a torque upon the spinning collar which causes the spinning collar to rotate within the support body. The engagement of the helical groove and the helical tongue redirects the rotational movement of the spinning collar to a translatory movement that moves the mounting collar and the pre-filled syringe in the proximal direction to a retracted position. In the retracted position, the injection needle is surrounded by the support body. The injection device comprising the pre-filled syringe and the safety device combines the aforementioned advantages and avoids inadvertent needle sticks injuries. The injection device is cheap to manufacture and is disposed after a single injection has been carried out.

The outer body may abut a plunger of the pre-filled syringe. Alternatively, the outer body may be attached to the plunger. A distal movement of the outer body with respect to the support body causes the plunger to depress into an inner cavity containing a dose of medication, whereby the dose of medication is expelled through the injection needle. The outer body may be gripped by the user and is manually pushed towards the skin of the patient in a single linear stroke to inject the dose of medication. The injection is carried out in a simple manner and may thus be safely performed even by inexperienced users.

The injection device is suited for self-administered injections and for injections administered by a health care professional. Consequently, the person referred to as the user or the patient may be one and the same person. Furthermore, the injection device may be used for intramuscular, subcutaneous or intravascular injections.

The pre-filled syringe may be filled with a medicament.

The term "medication", or "drug", or „medicament“, as used herein, means a pharmaceutical formulation containing at least one pharmaceutically active compound,

wherein in one embodiment the pharmaceutically active compound has a molecular weight up to 1500 Da and/or is a peptide, a proteine, a polysaccharide, a vaccine, a DNA, a RNA, , an enzyme, an antibody or a fragment thereof, a hormone or an oligonucleotide, or a mixture of the above-mentioned pharmaceutically active compound,

5

wherein in a further embodiment the pharmaceutically active compound is useful for the treatment and/or prophylaxis of diabetes mellitus or complications associated with diabetes mellitus such as diabetic retinopathy, thromboembolism disorders such as deep vein or pulmonary thromboembolism, acute coronary syndrome (ACS), angina, myocardial infarction, cancer, macular degeneration, inflammation, hay fever, atherosclerosis and/or rheumatoid arthritis,

10

wherein in a further embodiment the pharmaceutically active compound comprises at least one peptide for the treatment and/or prophylaxis of diabetes mellitus or complications associated with diabetes mellitus such as diabetic retinopathy,

15

wherein in a further embodiment the pharmaceutically active compound comprises at least one human insulin or a human insulin analogue or derivative, glucagon-like peptide (GLP-1) or an analogue or derivative thereof, or exendin-3 or exendin-4 or an analogue or derivative of exendin-3 or exendin-4.

20

Insulin analogues are for example Gly(A21), Arg(B31), Arg(B32) human insulin; Lys(B3), Glu(B29) human insulin; Lys(B28), Pro(B29) human insulin; Asp(B28) human insulin; human insulin, wherein proline in position B28 is replaced by Asp, Lys, Leu, Val or Ala and wherein in position B29 Lys may be replaced by Pro; Ala(B26) human insulin; Des(B28-B30) human insulin; Des(B27) human insulin and Des(B30) human insulin.

25

Insulin derivates are for example B29-N-myristoyl-des(B30) human insulin; B29-N-palmitoyl-des(B30) human insulin; B29-N-myristoyl human insulin; B29-N-palmitoyl human insulin; B28-N-myristoyl LysB28ProB29 human insulin; B28-N-palmitoyl-LysB28ProB29 human insulin; B30-N-myristoyl-ThrB29LysB30 human insulin; B30-N-palmitoyl- ThrB29LysB30 human insulin; B29-N-(N-palmitoyl-Y-glutamyl)-des(B30)

30

human insulin; B29-N-(N-lithocholyl-Y-glutamyl)-des(B30) human insulin; B29-N-( $\omega$ -carboxyheptadecanoyl)-des(B30) human insulin and B29-N-( $\omega$ -carboxyhepta-decanoyl) human insulin.

- 5 Exendin-4 for example means Exendin-4(1-39), a peptide of the sequence H His-Gly-Glu-Gly-Thr-Phe-Thr-Ser-Asp-Leu-Ser-Lys-Gln-Met-Glu-Glu-Glu-Ala-Val-Arg-Leu-Phe-Ile-Glu-Trp-Leu-Lys-Asn-Gly-Gly-Pro-Ser-Ser-Gly-Ala-Pro-Pro-Pro-Ser-NH<sub>2</sub>.

Exendin-4 derivatives are for example selected from the following list of compounds:

10

H-(Lys)<sub>4</sub>-des Pro<sub>36</sub>, des Pro<sub>37</sub> Exendin-4(1-39)-NH<sub>2</sub>,

H-(Lys)<sub>5</sub>-des Pro<sub>36</sub>, des Pro<sub>37</sub> Exendin-4(1-39)-NH<sub>2</sub>,

des Pro<sub>36</sub> Exendin-4(1-39),

des Pro<sub>36</sub> [Asp<sub>28</sub>] Exendin-4(1-39),

- 15 des Pro<sub>36</sub> [IsoAsp<sub>28</sub>] Exendin-4(1-39),

des Pro<sub>36</sub> [Met(O)<sub>14</sub>, Asp<sub>28</sub>] Exendin-4(1-39),

des Pro<sub>36</sub> [Met(O)<sub>14</sub>, IsoAsp<sub>28</sub>] Exendin-4(1-39),

des Pro<sub>36</sub> [Trp(O<sub>2</sub>)<sub>25</sub>, Asp<sub>28</sub>] Exendin-4(1-39),

des Pro<sub>36</sub> [Trp(O<sub>2</sub>)<sub>25</sub>, IsoAsp<sub>28</sub>] Exendin-4(1-39),

- 20 des Pro<sub>36</sub> [Met(O)<sub>14</sub> Trp(O<sub>2</sub>)<sub>25</sub>, Asp<sub>28</sub>] Exendin-4(1-39),

des Pro<sub>36</sub> [Met(O)<sub>14</sub> Trp(O<sub>2</sub>)<sub>25</sub>, IsoAsp<sub>28</sub>] Exendin-4(1-39); or

des Pro<sub>36</sub> [Asp<sub>28</sub>] Exendin-4(1-39),

des Pro<sub>36</sub> [IsoAsp<sub>28</sub>] Exendin-4(1-39),

- 25 des Pro<sub>36</sub> [Met(O)<sub>14</sub>, Asp<sub>28</sub>] Exendin-4(1-39),

des Pro<sub>36</sub> [Met(O)<sub>14</sub>, IsoAsp<sub>28</sub>] Exendin-4(1-39),

des Pro<sub>36</sub> [Trp(O<sub>2</sub>)<sub>25</sub>, Asp<sub>28</sub>] Exendin-4(1-39),

des Pro<sub>36</sub> [Trp(O<sub>2</sub>)<sub>25</sub>, IsoAsp<sub>28</sub>] Exendin-4(1-39),

des Pro<sub>36</sub> [Met(O)<sub>14</sub> Trp(O<sub>2</sub>)<sub>25</sub>, Asp<sub>28</sub>] Exendin-4(1-39),

- 30 des Pro<sub>36</sub> [Met(O)<sub>14</sub> Trp(O<sub>2</sub>)<sub>25</sub>, IsoAsp<sub>28</sub>] Exendin-4(1-39),

wherein the group -Lys<sub>6</sub>-NH<sub>2</sub> may be bound to the C-terminus of the Exendin-4 derivative;

or an Exendin-4 derivative of the sequence  
des Pro36 Exendin-4(1-39)-Lys6-NH2 (AVE0010),  
H-(Lys)6-des Pro36 [Asp28] Exendin-4(1-39)-Lys6-NH2,  
5 des Asp28 Pro36, Pro37, Pro38 Exendin-4(1-39)-NH2,  
H-(Lys)6-des Pro36, Pro38 [Asp28] Exendin-4(1-39)-NH2,  
H-Asn-(Glu)5des Pro36, Pro37, Pro38 [Asp28] Exendin-4(1-39)-NH2,  
des Pro36, Pro37, Pro38 [Asp28] Exendin-4(1-39)-(Lys)6-NH2,  
H-(Lys)6-des Pro36, Pro37, Pro38 [Asp28] Exendin-4(1-39)-(Lys)6-NH2,  
10 H-Asn-(Glu)5-des Pro36, Pro37, Pro38 [Asp28] Exendin-4(1-39)-(Lys)6-NH2,  
H-(Lys)6-des Pro36 [Trp(O2)25, Asp28] Exendin-4(1-39)-Lys6-NH2,  
H-des Asp28 Pro36, Pro37, Pro38 [Trp(O2)25] Exendin-4(1-39)-NH2,  
H-(Lys)6-des Pro36, Pro37, Pro38 [Trp(O2)25, Asp28] Exendin-4(1-39)-NH2,  
H-Asn-(Glu)5-des Pro36, Pro37, Pro38 [Trp(O2)25, Asp28] Exendin-4(1-39)-NH2,  
15 des Pro36, Pro37, Pro38 [Trp(O2)25, Asp28] Exendin-4(1-39)-(Lys)6-NH2,  
H-(Lys)6-des Pro36, Pro37, Pro38 [Trp(O2)25, Asp28] Exendin-4(1-39)-(Lys)6-NH2,  
H-Asn-(Glu)5-des Pro36, Pro37, Pro38 [Trp(O2)25, Asp28] Exendin-4(1-39)-(Lys)6-NH2,  
H-(Lys)6-des Pro36 [Met(O)14, Asp28] Exendin-4(1-39)-Lys6-NH2,  
des Met(O)14 Asp28 Pro36, Pro37, Pro38 Exendin-4(1-39)-NH2,  
20 H-(Lys)6-des Pro36, Pro37, Pro38 [Met(O)14, Asp28] Exendin-4(1-39)-NH2,  
H-Asn-(Glu)5-des Pro36, Pro37, Pro38 [Met(O)14, Asp28] Exendin-4(1-39)-NH2,  
des Pro36, Pro37, Pro38 [Met(O)14, Asp28] Exendin-4(1-39)-(Lys)6-NH2,  
H-(Lys)6-des Pro36, Pro37, Pro38 [Met(O)14, Asp28] Exendin-4(1-39)-(Lys)6-NH2,  
H-Asn-(Glu)5 des Pro36, Pro37, Pro38 [Met(O)14, Asp28] Exendin-4(1-39)-(Lys)6-NH2,  
25 H-Lys6-des Pro36 [Met(O)14, Trp(O2)25, Asp28] Exendin-4(1-39)-Lys6-NH2,  
H-des Asp28 Pro36, Pro37, Pro38 [Met(O)14, Trp(O2)25] Exendin-4(1-39)-NH2,  
H-(Lys)6-des Pro36, Pro37, Pro38 [Met(O)14, Asp28] Exendin-4(1-39)-NH2,  
H-Asn-(Glu)5-des Pro36, Pro37, Pro38 [Met(O)14, Trp(O2)25, Asp28] Exendin-4(1-39)-  
NH2,  
30 des Pro36, Pro37, Pro38 [Met(O)14, Trp(O2)25, Asp28] Exendin-4(1-39)-(Lys)6-NH2,  
H-(Lys)6-des Pro36, Pro37, Pro38 [Met(O)14, Trp(O2)25, Asp28] Exendin-4(S1-39)-  
(Lys)6-NH2,

H-Asn-(Glu)5-des Pro36, Pro37, Pro38 [Met(O)14, Trp(O2)25, Asp28] Exendin-4(1-39)-  
(Lys)6-NH<sub>2</sub>;

5 or a pharmaceutically acceptable salt or solvate of any one of the afore-mentioned  
Exendin-4 derivative.

Hormones are for example hypophysis hormones or hypothalamus hormones or  
regulatory active peptides and their antagonists as listed in Rote Liste, ed. 2008,  
Chapter 50, such as Gonadotropine (Follitropin, Lutropin, Choriongonadotropin,  
10 Menotropin), Somatropine (Somatropin), Desmopressin, Terlipressin, Gonadorelin,  
Triptorelin, Leuprorelin, Buserelin, Nafarelin, Goserelin.

A polysaccharide is for example a glucosaminoglycane, a hyaluronic acid, a heparin, a  
low molecular weight heparin or an ultra low molecular weight heparin or a derivative  
15 thereof, or a sulphated, e.g. a poly-sulphated form of the above-mentioned  
polysaccharides, and/or a pharmaceutically acceptable salt thereof. An example of a  
pharmaceutically acceptable salt of a poly-sulphated low molecular weight heparin is  
enoxaparin sodium.

20 Antibodies are globular plasma proteins (~150 kDa) that are also known as  
immunoglobulins which share a basic structure. As they have sugar chains added to  
amino acid residues, they are glycoproteins. The basic functional unit of each antibody  
is an immunoglobulin (Ig) monomer (containing only one Ig unit); secreted antibodies  
can also be dimeric with two Ig units as with IgA, tetrameric with four Ig units like teleost  
25 fish IgM, or pentameric with five Ig units, like mammalian IgM.

The Ig monomer is a "Y"-shaped molecule that consists of four polypeptide chains; two  
identical heavy chains and two identical light chains connected by disulfide bonds  
between cysteine residues. Each heavy chain is about 440 amino acids long; each light  
30 chain is about 220 amino acids long. Heavy and light chains each contain intrachain  
disulfide bonds which stabilize their folding. Each chain is composed of structural  
domains called Ig domains. These domains contain about 70-110 amino acids and are

classified into different categories (for example, variable or V, and constant or C) according to their size and function. They have a characteristic immunoglobulin fold in which two  $\beta$  sheets create a “sandwich” shape, held together by interactions between conserved cysteines and other charged amino acids.

5 There are five types of mammalian Ig heavy chain denoted by  $\alpha$ ,  $\delta$ ,  $\epsilon$ ,  $\gamma$ , and  $\mu$ . The type of heavy chain present defines the isotype of antibody; these chains are found in IgA, IgD, IgE, IgG, and IgM antibodies, respectively.

10 Distinct heavy chains differ in size and composition;  $\alpha$  and  $\gamma$  contain approximately 450 amino acids and  $\delta$  approximately 500 amino acids, while  $\mu$  and  $\epsilon$  have approximately 550 amino acids. Each heavy chain has two regions, the constant region (CH) and the variable region (VH). In one species, the constant region is essentially identical in all antibodies of the same isotype, but differs in antibodies of different isotypes. Heavy  
15 chains  $\gamma$ ,  $\alpha$  and  $\delta$  have a constant region composed of three tandem Ig domains, and a hinge region for added flexibility; heavy chains  $\mu$  and  $\epsilon$  have a constant region composed of four immunoglobulin domains. The variable region of the heavy chain differs in antibodies produced by different B cells, but is the same for all antibodies produced by a single B cell or B cell clone. The variable region of each heavy chain is  
20 approximately 110 amino acids long and is composed of a single Ig domain.

In mammals, there are two types of immunoglobulin light chain denoted by  $\lambda$  and  $\kappa$ . A light chain has two successive domains: one constant domain (CL) and one variable domain (VL). The approximate length of a light chain is 211 to 217 amino acids. Each  
25 antibody contains two light chains that are always identical; only one type of light chain,  $\kappa$  or  $\lambda$ , is present per antibody in mammals.

Although the general structure of all antibodies is very similar, the unique property of a given antibody is determined by the variable (V) regions, as detailed above. More  
30 specifically, variable loops, three each the light (VL) and three on the heavy (VH) chain, are responsible for binding to the antigen, i.e. for its antigen specificity. These loops are referred to as the Complementarity Determining Regions (CDRs). Because CDRs from

both VH and VL domains contribute to the antigen-binding site, it is the combination of the heavy and the light chains, and not either alone, that determines the final antigen specificity.

5 An "antibody fragment" contains at least one antigen binding fragment as defined above, and exhibits essentially the same function and specificity as the complete antibody of which the fragment is derived from. Limited proteolytic digestion with papain cleaves the Ig prototype into three fragments. Two identical amino terminal fragments, each containing one entire L chain and about half an H chain, are the antigen binding  
10 fragments (Fab). The third fragment, similar in size but containing the carboxyl terminal half of both heavy chains with their interchain disulfide bond, is the crystalizable fragment (Fc). The Fc contains carbohydrates, complement-binding, and FcR-binding sites. Limited pepsin digestion yields a single F(ab')<sub>2</sub> fragment containing both Fab pieces and the hinge region, including the H-H interchain disulfide bond. F(ab')<sub>2</sub> is  
15 divalent for antigen binding. The disulfide bond of F(ab')<sub>2</sub> may be cleaved in order to obtain Fab'. Moreover, the variable regions of the heavy and light chains can be fused together to form a single chain variable fragment (scFv).

Pharmaceutically acceptable salts are for example acid addition salts and basic salts.  
20 Acid addition salts are e.g. HCl or HBr salts. Basic salts are e.g. salts having a cation selected from alkali or alkaline, e.g. Na<sup>+</sup>, or K<sup>+</sup>, or Ca<sup>2+</sup>, or an ammonium ion N<sup>+</sup>(R1)(R2)(R3)(R4), wherein R1 to R4 independently of each other mean: hydrogen, an optionally substituted C1 C6-alkyl group, an optionally substituted C2-C6-alkenyl group, an optionally substituted C6-C10-aryl group, or an optionally substituted C6-C10-  
25 heteroaryl group. Further examples of pharmaceutically acceptable salts are described in "Remington's Pharmaceutical Sciences" 17. ed. Alfonso R. Gennaro (Ed.), Mark Publishing Company, Easton, Pa., U.S.A., 1985 and in Encyclopedia of Pharmaceutical Technology.

30 Pharmaceutically acceptable solvates are for example hydrates.

Further scope of applicability of the present invention will become apparent from the detailed description given hereinafter. However, it should be understood that the detailed description and specific examples, while indicating preferred embodiments of the invention, are given by way of illustration only, since various changes and  
5 modifications within the spirit and scope of the invention will become apparent to those skilled in the art from this detailed description.

#### Brief Description of the Drawings

- 10
- The present invention will be better understood from the detailed description given in the following. The accompanying drawings are given for illustrative purposes only and do not limit the scope of the present invention.
- 15        Figure 1                shows a perspective view of an injection device according to a first embodiment of the invention prior to use comprising a safety device and a pre-filled syringe;
- 20        Figure 2                shows a sectional view of an injection device according to the first embodiment of the invention prior to use;
- Figure 3                shows a perspective view of a spinning collar;
- 25        Figure 4A and 4B        shows two different sectional views of the injection device according to the first embodiment of the invention before an injection is performed;
- 30        Figure 5                shows a sectional view of the injection device according to the first embodiment of the invention comprising a needle shroud retracted in a second position;

- Figure 6 shows a sectional view of the injection device according to the first embodiment of the invention at the end of an injection stroke;
- 5 Figure 7 shows a sectional view of the injection device according to the first embodiment of the invention with a pre-filled syringe retracted within a support body.
- 10 Figure 8 shows a sectional view of an injection device according to a second embodiment in a packaged state.

Corresponding parts are marked with the same reference symbols in all figures.

#### 15 Detailed Description of Preferred Embodiments

Figure 1 shows an injection device D with a safety device 1 for a pre-filled syringe 2 according to a first embodiment of the invention as it would be presented to a user performing an injection. The safety device 1 comprises a substantially cylindrical and hollow needle shroud 1.1. The needle shroud 1.1 is received within a substantially cylindrical and hollow support body 1.2, wherein the needle shroud 1.1 is slidable with respect to the support body 1.2. Before usage of the safety device 1, the needle shroud 1.1 is retained in an initial first position I, wherein the needle shroud 1.1 protrudes the support body 1.2 in a distal direction.

25 Alternatively, the needle shroud 1.1 comprises a radial diameter that is sized to substantially receive the support body 1.2. In this alternative embodiment the support body 1.2 slides into the needle shroud 1.1 when the needle shroud 1.1 is moved from the first position I to a retracted second position II.

30 Figure 1 shows the safety device 1 that comprises an essentially cylindrical and hollow outer body 1.3 with an open distal and a closed proximal end. The proximal end of the

support body 1.2 is received within the open distal end of the outer body 1.3, whereas the outer body 1.3 is slidable with respect to the support body 1.2 in a distal direction to substantially receive the support body 1.2.

5 A circumferential and outwardly protruding support flange 1.3.1 is integrally formed to an outer surface of the outer body 1.3 close to its distal end. The outer body 1.3 may be gripped and pushed by a user in the distal direction, whereby the support flange 1.3.1 supports the hand of the user performing the injection stroke.

10 Preferably, the needle shroud 1.1, the support body 1.2 and the outer body 1.3 are made from a plastics material.

The needle shroud 1.1 comprises a circumferential first flange 1.1.1 at its distal end. The first flange 1.1.1 is adapted to be pressed against the skin of a patient and  
15 protrudes radial outwardly and perpendicularly to a central axis A of the safety device 1. Edges of the first flange 1.1.1 that may touch the skin of the patient are rounded to avoid injuries. The first flange 1.1.1 has a central opening centred on the central axis A of the safety device 1. The first flange 1.1.1 is integral to the needle shroud 1.1 or  
alternatively a separate part attached to the needle shroud 1.1 that is made from a  
20 plastics material.

In the packaged state shown in figures 1 and 2, an injection needle 2.1 of the pre-filled syringe 2 is covered by a needle cap 2.2. Preferably, the needle cap 2.2 is at least partially made from a plastics material like rubber. The needle cap 2.2 protrudes the first  
25 flange 1.1.1 in the distal direction, so that the user can easily remove the needle cap 2.2 before an injection is performed.

Figure 2 shows a perspective view of the injection device D as it would be delivered to a user. The injection device D comprises the safety device 1 and the pre-filled syringe 2  
30 that is received in the support body 1.2. The pre-filled syringe 2 comprises the injection needle 2.1 covered by a needle cap 2.2 frictionally affixed to a distal end of a barrel 2.3. The barrel 2.3 has an inner cavity 2.3.1 containing a dose of medication. The inner

cavity 2.3.1 is in fluid communication with the injection needle 2.1. A proximal end of the inner cavity 2.3.1 is fluid-tightly sealed by a stopper 2.4 that is connected to a plunger 2.5. The stopper 2.4 is movable in at least the distal direction by pushing the plunger 2.5 protruding the barrel 2.3 in the proximal direction.

5

The barrel 2.3 of the pre-filled syringe 2 comprises a barrel collar 2.3.2 that is attached to a mounting collar 1.4 mounting the pre-filled syringe 2 within the support body 1.2. A catch 1.4.1 formed to the mounting collar 1.4 releasably mounts the mounting collar 1.4 to the support body 1.2. The catch 1.4.1 protrudes through an aperture 1.2.1 formed into the support body 1.2 to mount the mounting collar 1.4 and the pre-filled syringe 2 attached thereto in an advanced position PA, wherein the injection needle 2.1 protrudes the support body 1.2 in the distal direction.

10

Upon release, the mounting collar 1.4 may travel proximally with respect to the support body 1.2 in a linear translatory motion. A linear guide rail or channel is formed to an inner surface of the support body 1.2 that engages the mounting collar 1.4 to prevent a rotation, so that the mounting collar 1.4 is forced to move in a linear motion with respect to the support body 1.2.

15

A spinning collar 1.5 comprises a proximal bearing surface 1.5.1 that bears against the mounting collar 1.4 in the proximal direction. The spinning collar 1.5 is biased by a torsion spring 1.6 arranged within the support body 1.2. The torsion spring 1.6 is in a pre-tensioned state and thus capable of exerting a torque upon the spinning collar 1.5 to make the spinning collar 1.5 rotate around the central axis A of the injection device D.

20

25

The spinning collar 1.5 comprises a helical tongue 1.5.2 that is accommodated in a helical groove 1.2.2 formed to an inner surface of the support body 1.2. The engagement of the helical tongue 1.5.2 and the helical groove 1.2.2 redirects a rotational movement of the spinning collar 1.5 into a translatory motion, so that the released mounting collar 1.4 may be pushed proximally by the rotating spinning collar 1.5.

30

The torsion spring 1.6 bears against an inner bearing surface 1.2.3 of the support body 1.2 in the distal direction and against the spinning collar 1.5 in the proximal direction.

- 5 The plunger 2.5 abuts an inner surface of the outer body 1.3, so that the plunger 2.5 may be depressed into the inner cavity 2.3.1 of the barrel 2.3 by manually pushing the outer body 1.3 in the distal direction.

10 Figure 3 shows the spinning collar 1.5 with the helical tongue 1.5.2 formed to the outer surface thereof in a perspective view. The bearing surface 1.5.1 of the spinning collar 1.5 is essentially ring-shaped and reduces the area of the spinning collar 1.5 that abuts the mounting collar 1.4. Thus, occurring friction between a rotating spinning collar 1.5 and the rotationally fixed mounting collar 1.4 is reduced.

- 15 Figures 4A and 4B show two different sectional views of the injection device D according to the first embodiment of the invention before an injection is performed. The sectional plane shown in figure 4A extends perpendicularly to the one shown in figure 4B. The needle cap 2.2 has been pulled off to uncover the injection needle 2.1. The needle shroud 1.1 is positioned in the first position I and surrounds the injection  
20 needle 2.1 before the injection.

The injection device D comprising the safety device 1 and the pre-filled syringe 2 may be used to inject a dose of medication as follows: After removal of the needle cap 2.2, the first flange 1.1.1 of the needle shroud 1.1 is pressed against the injection site. The  
25 needle shroud 1.1 is moved from the advanced first position I towards a retracted second position II shown in figure 5.

Figure 5 shows a sectional view of the injection device D according to the first embodiment of the invention. The needle shroud 1.1 is retracted in the second  
30 position II. The injection needle 2.1 punctures the skin of the patient receiving the injection. The outer body 1.3 is pushed distally towards the skin of the patient, whereby the plunger 2.5 is depressed into the inner cavity 2.3.1. The dose of medication

contained in the inner cavity 2.3.1 is expelled through the injection needle 2.1 and disposed beneath the skin of the patient.

5 The outer body 1.3 is moved distally in a single injection stroke delivering the dose of medication until the stopper 2.4 reaches a distal end of the inner cavity 2.3.1 as illustrated in figure 6.

10 Figure 6 shows a sectional view of the injection device D according to the first embodiment of the invention at the end of an injection stroke. The plunger 2.5 is fully depressed in the inner cavity 2.3.1. The support body 1.2 is substantially received within the outer body 1.3. An inner surface of the outer body 1.3 bears against the catch 1.4.1 and deflects the catch 1.4.1 radially inwards. The catch 1.4.1 disengages the aperture 1.2.1, whereby the mounting collar 1.4 is released. The released mounting collar 1.4 is thus allowed to move proximally in a linear translatory motion.

15 The injection device D is removed from the injection site. The torsion spring 1.6 relaxes and exerts a torque upon the spinning collar 1.5 which in turn starts to rotate around the central axis A. As the spinning collar 1.5 is mounted to the support body 1.2 by a thread-like connection comprising the helical groove 1.2.2 accommodating the helical tongue 1.5.2, the rotating spinning collar 1.5 moves proximally within the support body 1.2. At the same time, the bearing surface 1.5.1 abuts the released mounting collar 1.4 and pushes the mounting collar 1.4 and the pre-filled syringe 2 attached thereto in the proximal direction towards a retracted position PR shown in figure 7.

25 Figure 7 shows a sectional view of the injection device D according to the first embodiment of the invention with the pre-filled syringe 2 located in the retracted position PR. The pre-filled syringe 2 is retracted within the support body 1.2. The needle shroud 1.1 surrounds the injection needle 2.1 to prevent accidental needle stick injuries. The catch 1.4.1 latches to a proximal end of the support body 1.2 so that a subsequent  
30 distal movement of the pre-filled syringe 2 with respect to the support body 2 is prevented. Thus, the mounting collar 1.4 and the pre-filled syringe 2 attached thereto is locked in the retracted position PR, so that a re-exposure of the injection needle 2.1 is

prevented and an inadvertent contact with the used injection needle 2.1 is efficiently avoided.

5 Figure 8 shows a sectional view of an injection device D according to a second embodiment in a packaged state as it would be delivered to the user. The injection device D does not comprise a needle shroud 1.1. Instead, a second flange 1.2.4, that is adapted to be pressed against the skin surface of the patient, is formed to a distal end of the support body 1.2.

10 After removal of the needle cap 2.2, the injection needle 2.1 is inserted into the skin of the patient. During the injection, the second flange 1.2.4 rests on the skin surface of the patient. The injection device D according to the second embodiment is designed similar to the one of the first embodiment and works essentially as described herein above. In particular, the injection is carried out as already described herein above with the  
15 exception that the needle shroud 1.1 has been omitted.

## List of References

	1	safety device
	1.1	needle shroud
5	1.1.1	first flange
	1.2	support body
	1.2.1	aperture
	1.2.2	helical groove
	1.2.3	inner bearing surface
10	1.2.4	second flange
	1.3	outer body
	1.3.1	support flange
	1.4	mounting collar
	1.4.1	catch
15	1.5	spinning collar
	1.5.1	bearing surface
	1.5.2	helical tongue
	1.6	torsion spring
	2	pre-filled syringe
20	2.1	injection needle
	2.2	needle cap
	2.3	barrel
	2.3.1	inner cavity
	2.3.2	barrel collar
25	2.4	stopper
	2.5	plunger
	D	injection device
	A	central axis
	I	first position
30	II	second position
	PA	advanced position
	PR	retracted position

## Claims

1. A safety device (1) for a pre-filled syringe (2) comprising
  - a hollow support body (1.2) with a helical groove (1.2.2) formed into an inner surface thereof,
  - 5 - a mounting collar (1.4) for mounting the pre-filled syringe (2) to the support body (1.2),
  - a spinning collar (1.5) with a helical tongue (1.5.2) formed to an outer surface thereof and
  - a torsion spring (1.6),

10 wherein the helical groove (1.2.2) accommodates the helical tongue (1.5.2) and, upon release, the torsion spring (1.6) is capable of exerting a torque upon the spinning collar (1.5), which causes the spinning collar (1.5) to rotate within the support body (1.2), whereby the engagement of the helical groove (1.2.2) and the helical tongue (1.5.2) redirects the rotational movement of the spinning

15 collar (1.5) to a translatory movement that moves the mounting collar (1.4) in a proximal direction.
2. A safety device (1) according to claim 1,  
characterized in that the torsion spring (1.6) is arranged within the support  
20 body (1.2) in a pre-tensioned state.
3. A safety device (1) according to claim 1 or 2,  
characterized in that the spinning collar (1.5) comprises a bearing surface (1.5.1)  
that bears against the mounting collar (1.4) in the proximal direction.  
25
4. A safety device (1) according to one of the previous claims,  
characterized in that the mounting collar (1.4) is releasably mounted to the  
support body (1.2) by a catch (1.4.1) protruding through an aperture (1.2.1)  
formed into the support body (1.2).  
30
5. A safety device (1) according to claim 4,  
characterized in that an outer body (1.3) is slidably arranged with respect to the

support body (1.2), wherein the outer body (1.3) substantially receives the support body (1.2) at the end of an injection stroke, whereby the catch (1.4.1) is deflected inwardly to release the mounting collar (1.4).

- 5 6. A safety device (1) according to claim 4 or 5,  
characterized in that the catch (1.4.1) latches to a distal end of the support  
body (1.2) to lock the mounting collar (1.4) in a retracted position (PR).
- 10 7. A safety device (1) according to one of the previous claims,  
characterized in that a needle shroud (1.1) is slidably arranged with respect to  
the support body (1.2), wherein a first flange (1.1.1), that is adapted to be  
pressed against a skin surface, is formed to a distal end of the needle  
shroud (1.1).
- 15 8. A safety device (1) according to claim 1 to 7,  
characterized in that a second flange (1.2.4), that is adapted to be pressed  
against skin surface, is formed to a distal end of the support body (1.2).
- 20 9. An injection device (D) comprising a safety device (1) according to one of the  
previous claims and a pre-filled syringe (2) with an injection needle (2.1), wherein  
the safety device (1) comprises
- a hollow support body (1.2) with a helical groove (1.2.2) formed into an  
inner surface thereof,
  - a mounting collar (1.4) for mounting the pre-filled syringe (2) to the support  
25 body (1.2),
  - a spinning collar (1.5) with a helical tongue (1.5.2) formed to an outer  
surface thereof and
  - a torsion spring (1.6),
- 30 wherein the helical groove (1.2.2) accommodates the helical tongue (1.5.2) and,  
upon release, the torsion spring (1.6) is capable of exerting a torque upon the  
spinning collar (1.5), which causes the spinning collar (1.5) to rotate within the  
support body (1.2), whereby the engagement of the helical groove (1.2.2) and the

helical tongue (1.5.2) redirects the rotational movement of the spinning collar (1.5) to a translatory movement that moves the mounting collar (1.4) and the pre-filled syringe (2) in the proximal direction to a retracted position (PR), in which the injection needle (2.1) is surrounded by the support body (1.2).

5

10. An injection device (D) according to claim 9, characterized in that the outer body (1.3) abuts a plunger (2.5) of the pre-filled syringe (2), so that a distal movement of the outer body (1.3) with respect to the support body (1.2) causes the plunger (2.5) to depress into an inner cavity (2.3.1) containing a dose of medication, whereby the dose of medication is expelled through the injection needle (2.1).

10

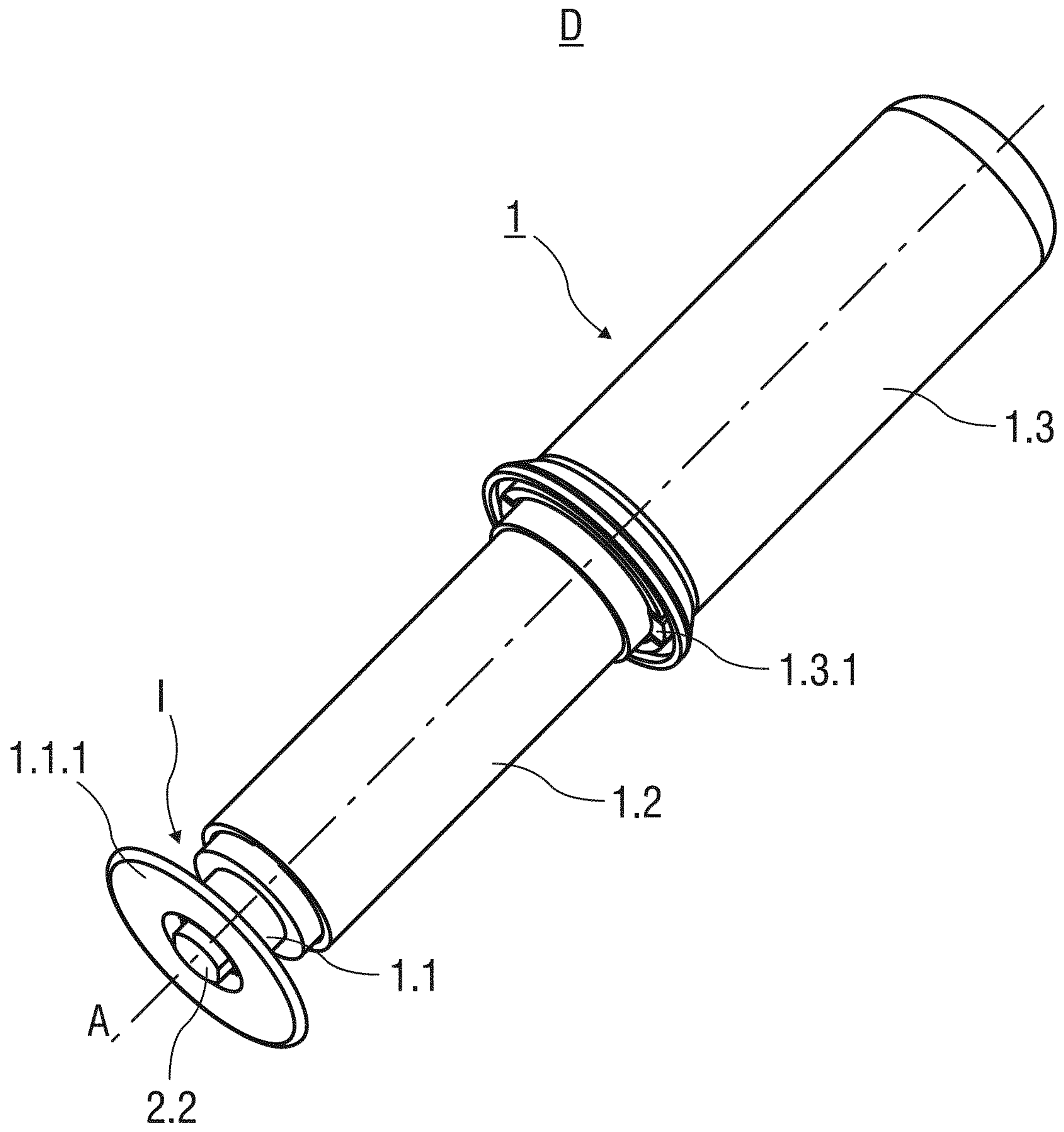

FIG 1

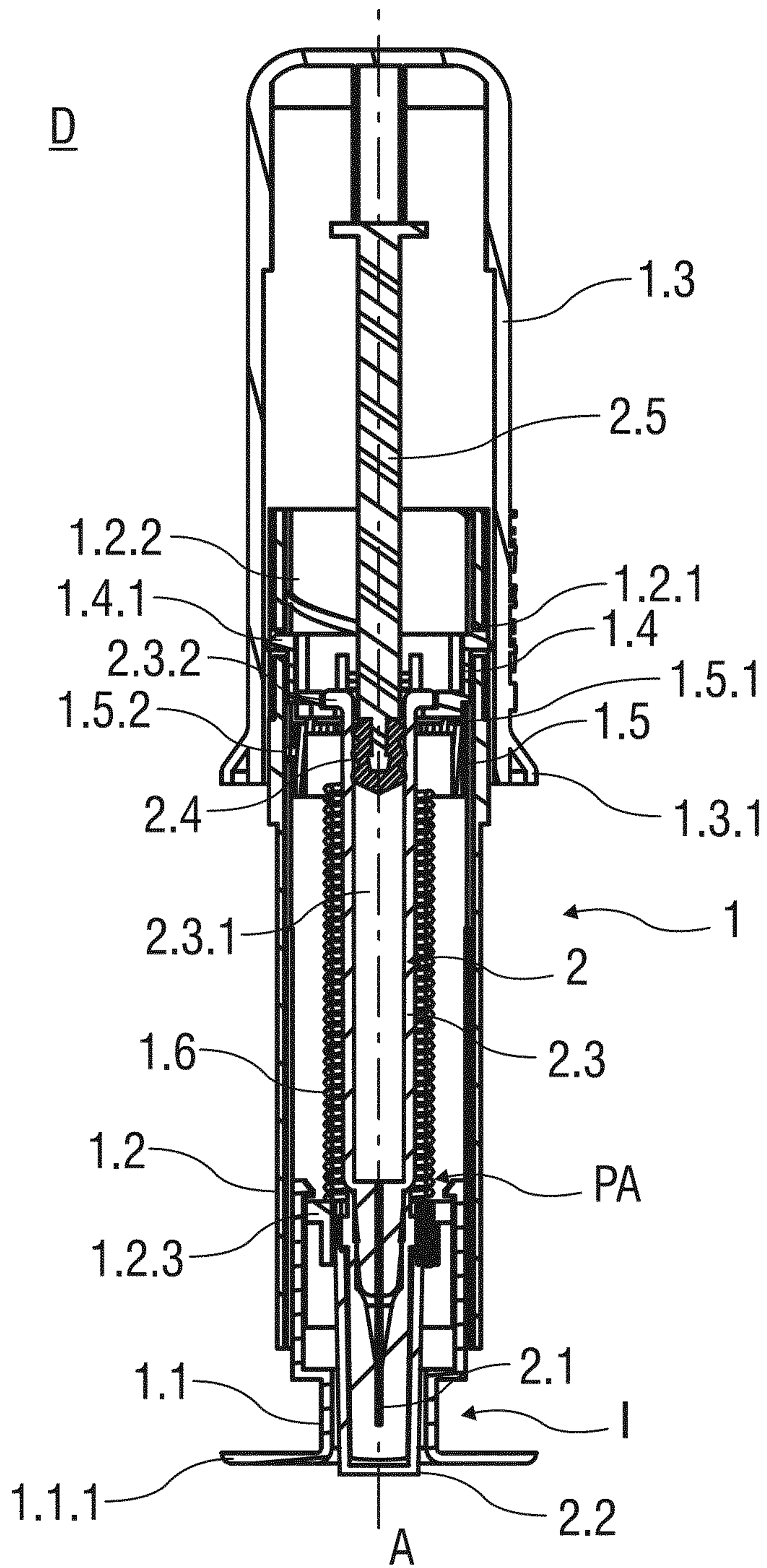

FIG 2

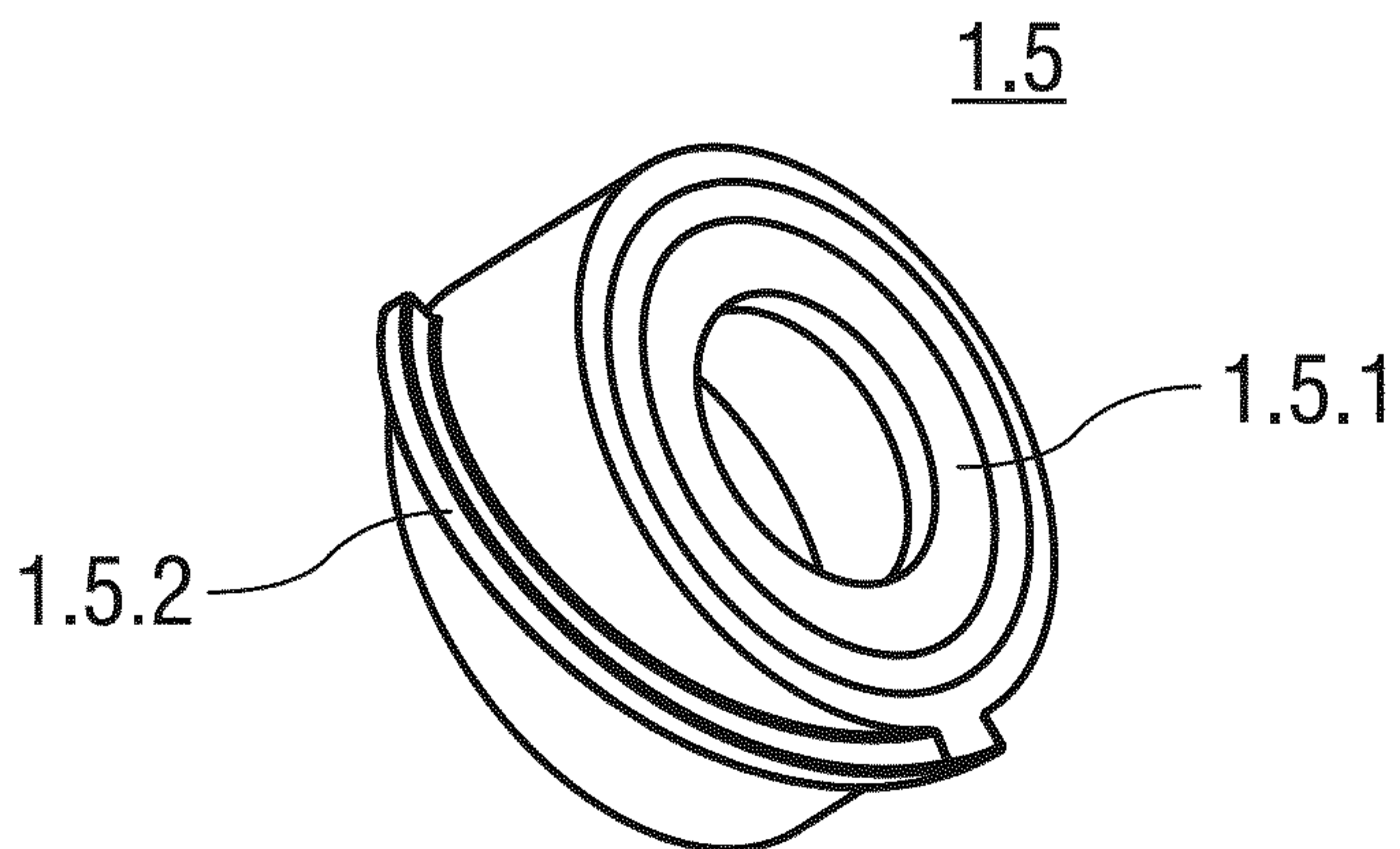

FIG 3

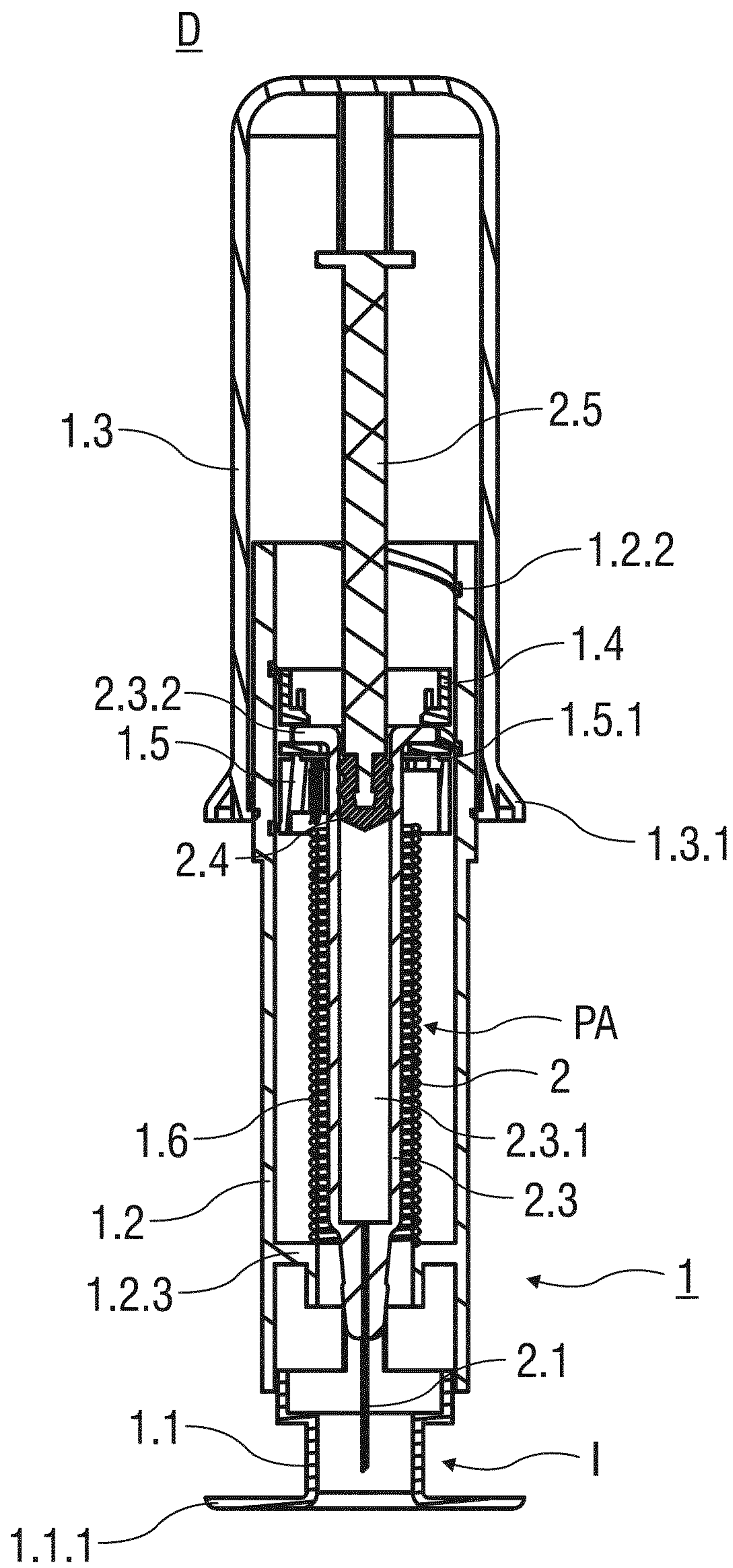

FIG 4A

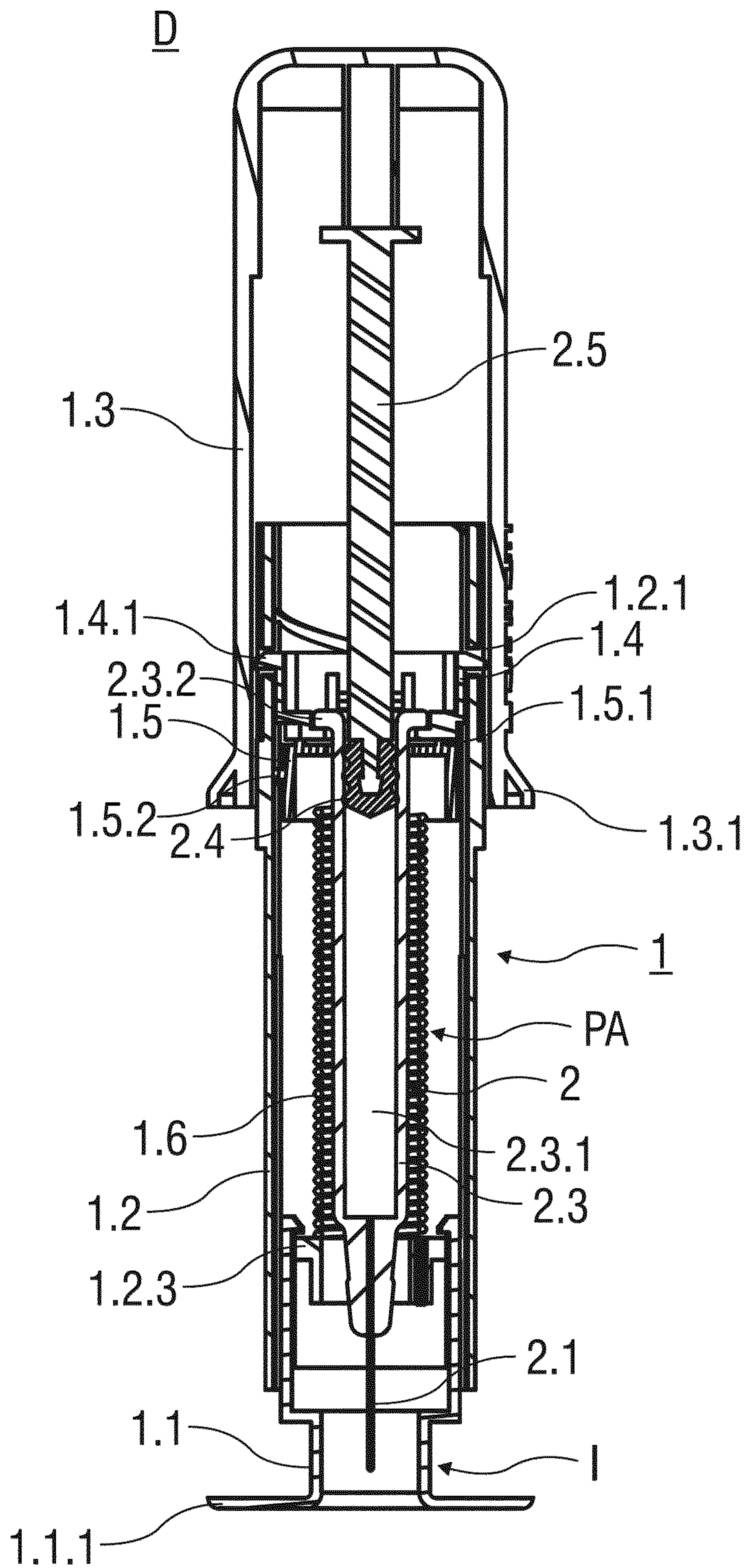

FIG 4B

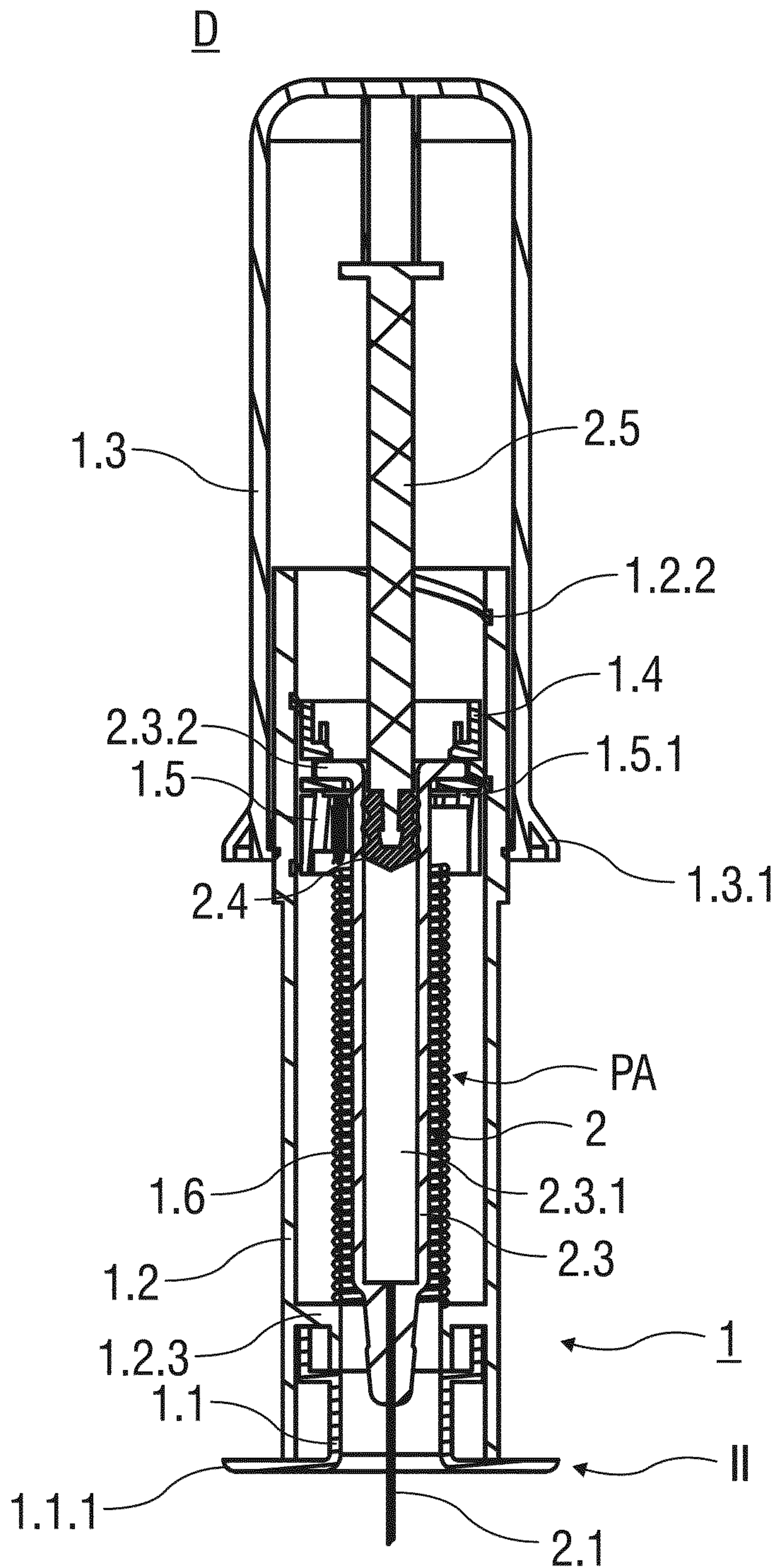

FIG 5

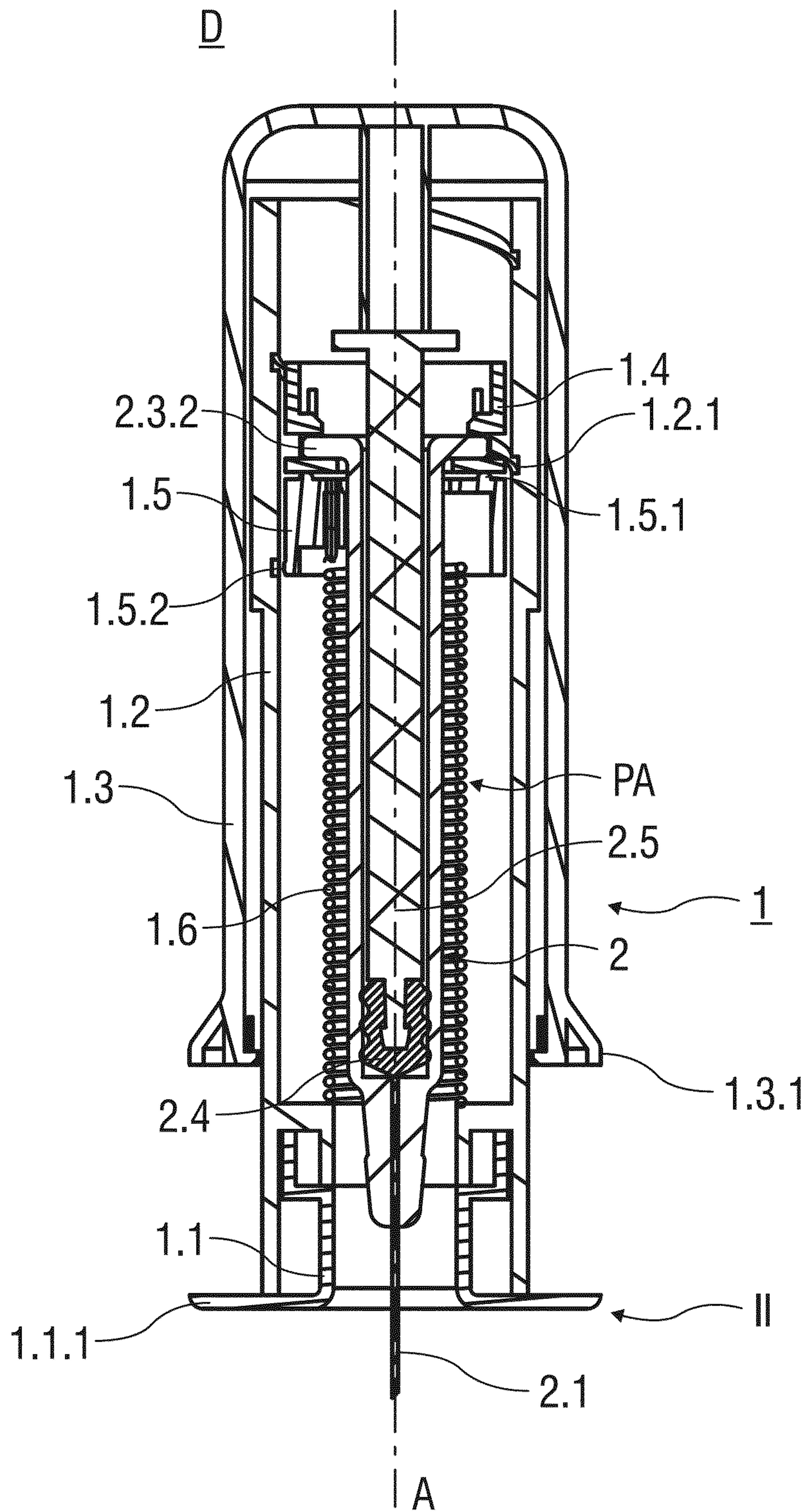

FIG 6

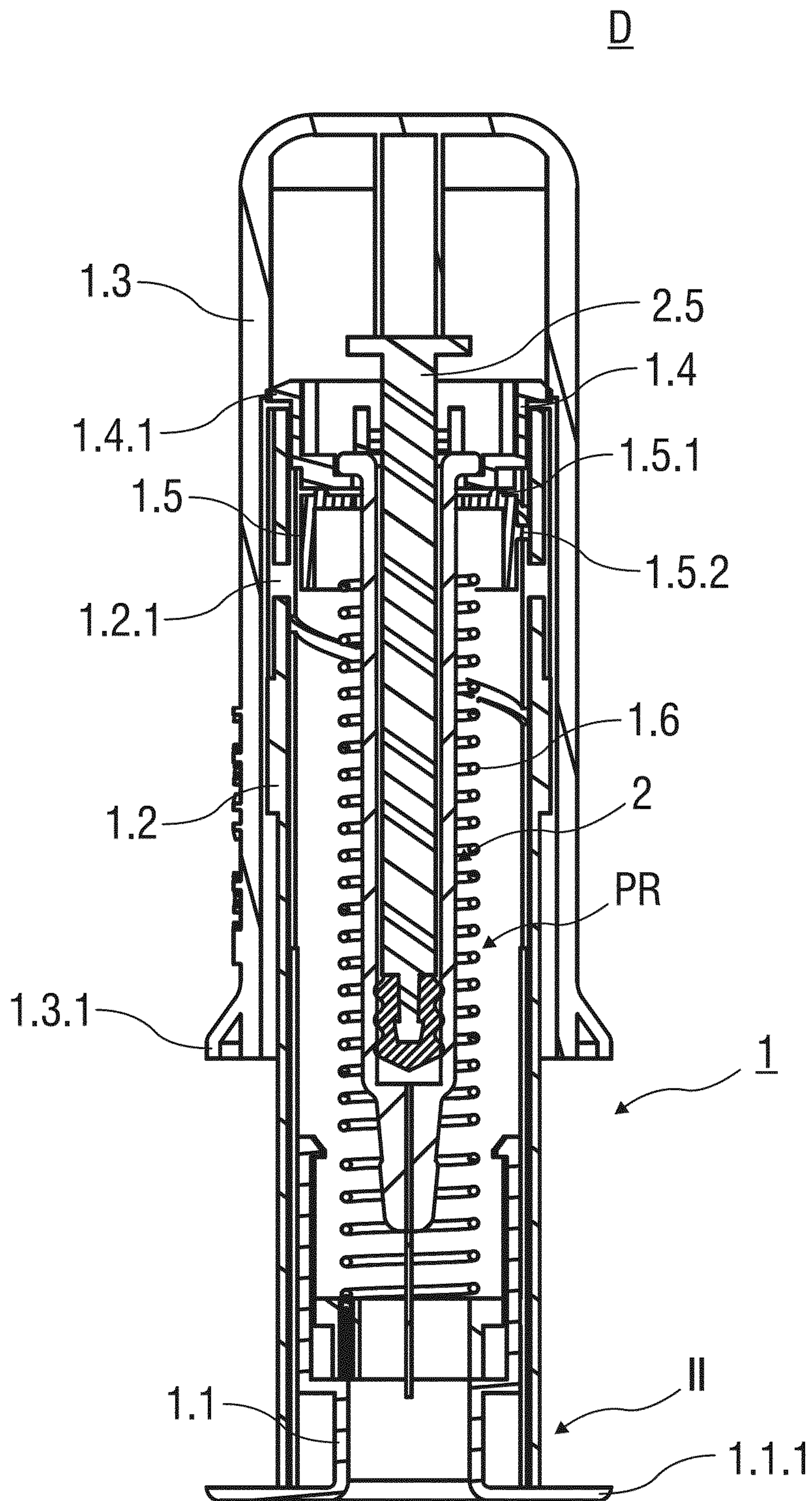

FIG 7

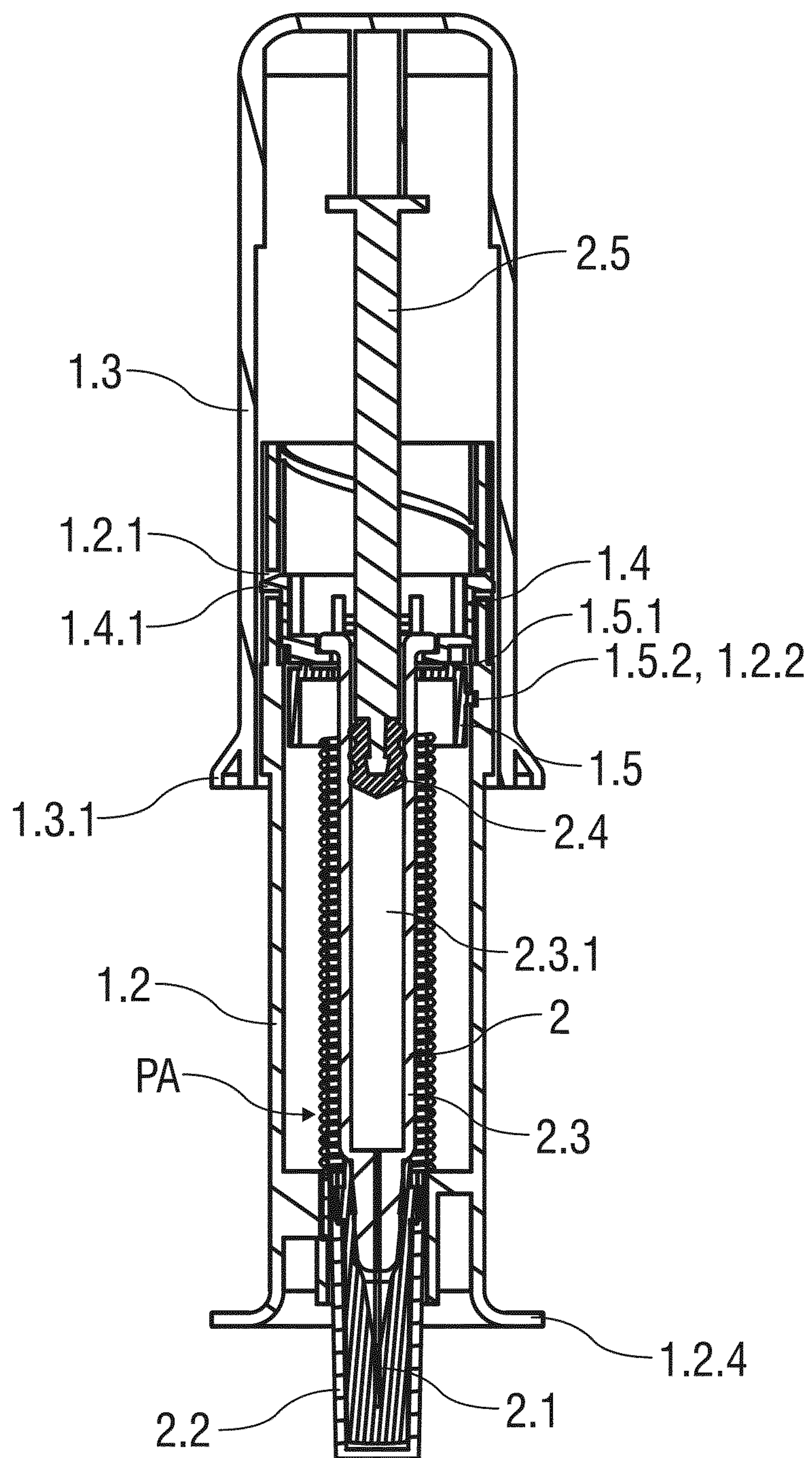
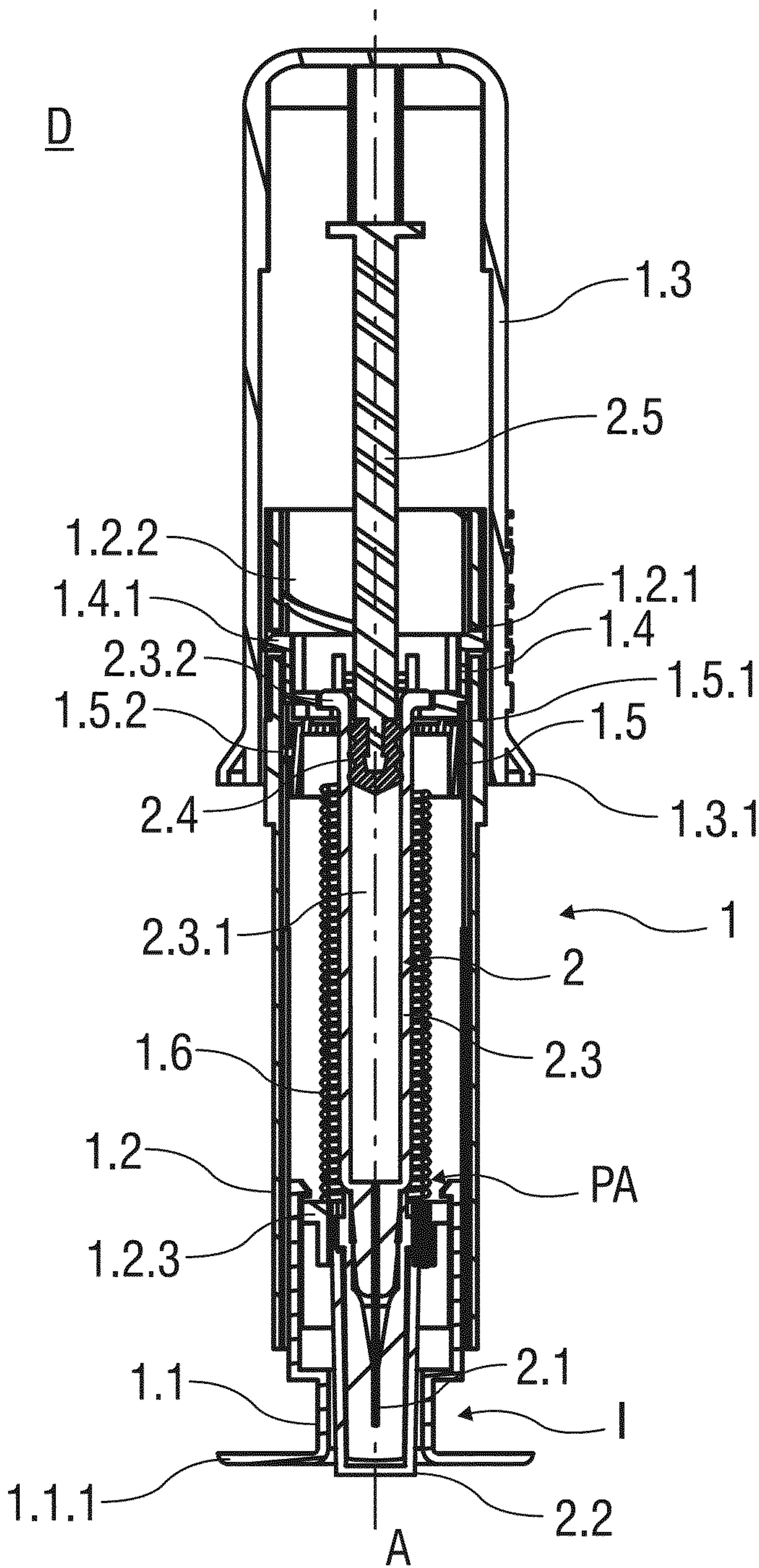

FIG 8



**FIG 2**