

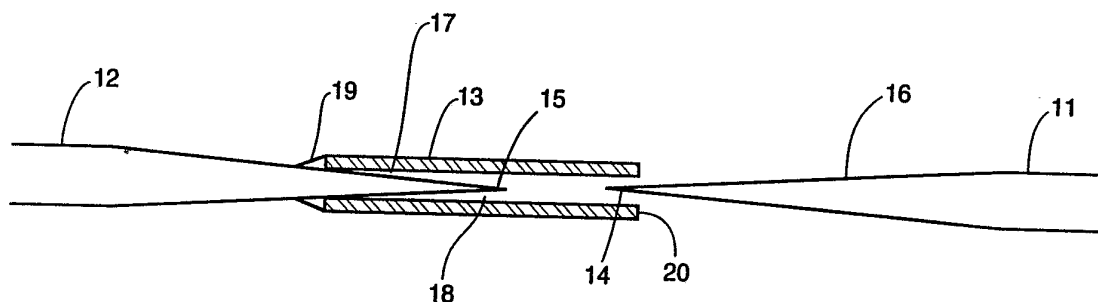

## INTERNATIONAL APPLICATION PUBLISHED UNDER THE PATENT COOPERATION TREATY (PCT)

<b>(51) International Patent Classification <sup>5</sup> :</b>  <b>A61M 25/00</b>	<b>A1</b>	<b>(11) International Publication Number:</b> <b>WO 93/03786</b>  <b>(43) International Publication Date:</b> 4 March 1993 (04.03.93)
<b>(21) International Application Number:</b> PCT/US92/07035 <b>(22) International Filing Date:</b> 19 August 1992 (19.08.92)  <b>(30) Priority data:</b> 750,558                      26 August 1991 (26.08.91)                      US  <b>(71) Applicant:</b> TARGET THERAPEUTICS, INC. [US/US]; 47201 Lakeview Boulevard, P.O. Box 5120, Fremont, CA 94537-5120 (US).  <b>(72) Inventor:</b> SAMSON, Gene ; 645 Vasona Street, Milpitas, CA 95035 (US).  <b>(74) Agents:</b> CIOTTI, Thomas, E. et al.; Morrison & Foerster, 755 Page Mill Road, Palo Alto, CA 94303-1018 (US).		<b>(81) Designated States:</b> AU, CA, CS, FI, HU, JP, KR, NO, Eu- ropean patent (AT, BE, CH, DE, DK, ES, FR, GB, GR, IE, IT, LU, MC, NL, SE).  <b>Published</b> <i>With international search report.</i>

**(54) Title:** EXTENDABLE GUIDEWIRE ASSEMBLY**(57) Abstract**

An extendable guidewire assembly comprising: a guidewire (11) having a tapered proximal end; an extension wire (12) having a tapered distal end; and a polymeric tubular sleeve (13) that is fixedly attached about the tapered distal end of the extension wire such that the tapered distal end of the extension wire extends partly through the sleeve lumen, said lumen having a diameter that is smaller than the untapered diameter of the guidewire and wherein said lumen expands radially when the sleeve is under axial compression and contracts radially when the sleeve is under axial tension.

*FOR THE PURPOSES OF INFORMATION ONLY*

Codes used to identify States party to the PCT on the front pages of pamphlets publishing international applications under the PCT.

AT	Austria	FI	Finland	MN	Mongolia
AU	Australia	FR	France	MR	Mauritania
BB	Barbados	GA	Gabon	MW	Malawi
BE	Belgium	GB	United Kingdom	NL	Netherlands
BF	Burkina Faso	GN	Guinea	NO	Norway
BG	Bulgaria	GR	Greece	NZ	New Zealand
BJ	Benin	HU	Hungary	PL	Poland
BR	Brazil	IE	Ireland	PT	Portugal
CA	Canada	IT	Italy	RO	Romania
CF	Central African Republic	JP	Japan	RU	Russian Federation
CG	Congo	KP	Democratic People's Republic of Korea	SD	Sudan
CH	Switzerland	KR	Republic of Korea	SE	Sweden
CI	Côte d'Ivoire	LI	Liechtenstein	SK	Slovak Republic
CM	Cameroon	LK	Sri Lanka	SN	Senegal
CS	Czechoslovakia	LU	Luxembourg	SU	Soviet Union
CZ	Czech Republic	MC	Monaco	TD	Chad
DE	Germany	MG	Madagascar	TG	Togo
DK	Denmark	MI	Mali	UA	Ukraine
ES	Spain			US	United States of America

5

EXTENDABLE GUIDEWIRE ASSEMBLYDescription10 Technical Field

This invention is in the general field of surgical instruments and relates specifically to an extendable guidewire assembly that is used in cardiovascular and endovascular procedures to facilitate the placement of catheters within the vasculature of patients.

Background

The general procedure for placing catheters within vessels is to track a guidewire through the vessel to the desired position and advance the catheter over the guidewire. Guidewires are required because the catheters themselves do not have sufficient column strength or torqueability to be able to be tracked or steered through the vessel. See, for instance, U.S. Pat. No. 4,884,579.

In some procedures such as angioplasty using dilatation balloon catheters, it is necessary to exchange catheters to increase balloon size. It may also be necessary in some instances to replace catheters due to material fatigue. Two guidewire techniques have been employed in such instances. In one, the initial guidewire is removed and replaced with an exchange wire that is somewhat greater than double the length of the catheter. In order to avoid the need for a separate

35

exchange wire a second technique that involves attaching an extension wire to the initial guidewire was developed.

U.S. Pats. Nos. 4,917,103 and 4,922,923 describe an extendable guidewire assembly that employs a sleeve that is connected to the proximal end of the guidewire and into which the distal end of the extension wire is inserted. The sleeve and extension are then crimped to form a permanent joint or union between the two wires.

U.S. 4,875,489 describes another type of extendable guidewire assembly in which one of the wires has a tapered tip and the other has an expandable sleeve into which the tip is received. A second concentric sleeve encloses the expandable sleeve to ensure a friction fit between the tapered tip and expandable sleeve.

U.S. 4,966,163 describes yet another kind of extendable guidewire assembly. In this assembly one of the wires carries an internally threaded sleeve and the other wire carries a threaded head. The two wires are coupled together by threading the head into the sleeve.

Commonly-owned copending U.S. application Serial No. 688,915, filed 19 April 1991, describes an extendable guidewire assembly in which the ends of the guidewire and extension wire carry axial interlocking members and the extension wire carries a retractable sleeve which encloses the interlocked members.

Applicant is also aware of an extendable guidewire assembly design in which one of the wires carries an open-ended sleeve and the other wire has a tapered tip encircled by a helical coil. The wires are coupled by inserting the tip into the sleeve and twisting it. The twisting causes the coil to expand and form a friction fit with the interior of the sleeve. The wires

are uncoupled by twisting the tapered tip wire in the reverse direction.

A primary object of the present invention is to provide an extendable guidewire assembly that may be connected and disconnected and is relatively simple to manufacture.

#### Disclosure of the Invention

The invention is an extendable guidewire assembly for use within a patient's vasculature comprising in combination:

- (a) a guidewire having a distal end that is adapted to be fed into said vasculature and a tapered proximal end;
- (b) an extension wire having a proximal end and a tapered distal end; and
- (c) a polymeric sleeve having first and second ends and a lumen extending therebetween, said first end being fixedly attached concentrically about one of either the proximal end of the guidewire or the distal end of the extension wire such that said one end extends partly through the lumen of the sleeve, said second end being adapted to receive the other of the proximal end of the guidewire or the distal end of the extension wire, said lumen having a diameter that is smaller than the untapered diameter of the wire to which the sleeve is not fixedly attached and wherein the lumen expands radially when the sleeve is under axial compression and contracts radially when the sleeve is under axial tension.

#### Brief Description of the Drawings

Figure 1 is a fragmentary elevational view of a preferred embodiment of the extendable guidewire with the guidewire and extension wire in a disconnected configuration.

Figure 2 is a fragmentary elevational view of the embodiment of Figure 1 with the guidewire and extension wires on their connected configurations.

5 Modes for Carrying Out the Invention

The drawings illustrate the preferred embodiment of the extendable guidewire assembly of the invention. The three principal components of the assembly are: a guidewire 11, an extension wire 12, and  
10 a sleeve 13. In these figures only the proximal end 14 of the guidewire and the distal end 15 of the extension wire are shown. The remainders of the two wires are not shown and are of conventional structure.

While this invention may be practiced with  
15 guidewires of any length and diameter, it will typically be employed with stainless steel or nickel-titanium alloy guidewires and extensions that are  $\leq 0.46$  mm in diameter (untapered), more normally 0.25 to 0.40 mm in diameter (untapered). Preferably, the diameters of the guidewire  
20 and extension wire are the same. In most instances the length of the guidewire will be in the range of 100-200 cm and the extension will be on the order of 125 to 225 cm in length.

The proximal end 14 of guidewire 11 has a  
25 tapered section 16. For manufacturing convenience the taper will normally be conical, although other taper configurations may be used. The taper is continuous and the length of section 16 will normally be 3 to 7 cm, more usually 5 to 6 cm.

30 The distal end 15 of the extension wire 12 has a similarly tapered section 17. It, too, is preferably conical, continuous and extends over a length of 3 to 7 cm, usually 5 to 6 cm.

Sleeve 13 preferably has an outer diameter that  
35 is equal to or less than the outer diameters of the

untapered portions of the guidewire and extension wire. Correspondingly, the diameter of its lumen 18 will be less than the individual diameters (untapered) of the two wires. The lumen diameter will typically be 0.2 to  
5 0.36 mm, more usually 0.25 to 0.30 mm. In the embodiment shown in the drawing the sleeve is attached to the tapered end of the extension wire by means of an adhesive 19. Because the diameter of the lumen 18 is smaller than the untapered diameter of the extension wire, the site of  
10 affixation is on the tapered portion.

The length of tubular sleeve 13 is such that the tapered portion 17 of the extension wire extends within the lumen over half the length of the sleeve. As shown in the drawing, when the wires are connected the  
15 tapered end of the guidewire also extends into the lumen over half the length of the sleeve. Thus, the tapered tips of the wires axially overlap within the lumen. With wires of the dimensions given above, the length of the sleeve will usually be 5 to 8 cm, more usually 6 to  
20 7.5 cm.

The tube is made of a polymer that will provide a friction fit between the contact surface between its inner wall and the tapered section 16 of the guidewire. Further, the nature of the mechanical properties of the  
25 polymer and the wall thickness of the sleeve are such that the sleeve will act as a "Chinese finger tube" and its lumen will expand when the sleeve is under axial compression and contract when the sleeve is under axial tension. In this regard the wall thickness of the sleeve  
30 will usually be 0.025 to 0.05 mm and the sleeve will be made of polyimide or other polymer of like mechanical properties.

The guidewire and extension wire are connected by simply inserting the tapered end of the guidewire into  
35 the sleeve until a tight friction fit between the sleeve

and the tapered end of the guidewire is achieved. (See Fig. 2.) Locking of the connection between the wires may be verified by applying axial tension to both wires close to the sleeve junction. Because of the "Chinese finger tube" fit, the wires can be disconnected only by placing force on (gripping) the distal end face of the sleeve, and pulling the tapered end of the guidewire from the lumen. Any manipulation that places the sleeve under axial tension contracts the lumen and exerts radial force at the contact surfaces of the sleeve and the tapered portion of the guidewire.

An extendable guidewire assembly according to the invention was made as follows. Using a centerless grinder, the proximal end a 195 cm long stainless steel catheter guidewire having a 0.014" OD was ground to 0.002" tip OD with a 6.0 cm taper length. The end of a different wire of the same diameter, about 160 cm long, was ground similarly as the guidewire. This wire served as the extension wire. Polyimide tubing (purchased from H.V. Technology) with a 0.013" OD and a 0.001" wall thickness was cut squarely to about 7.5 cm long. A thin film of epoxy adhesive was applied on the ground segment of the extension wire. The tip of the extension wire was inserted into the polyimide tubing and pressed until the wire locked. The epoxy was allowed to cure overnight. Alternatively the epoxy may be cured by heating for 3 min at  $\approx 135^{\circ}\text{C}$ . Extension of the guidewire was accomplished by inserting the ground proximal end of the guidewire into the polyimide tube of the extension wire. The catheter wire was pressed firmly into the tubing.

While the above-described embodiment shows the sleeve affixed to the extension wire, it will be appreciated that the respective wire structures may be reversed (i.e., the sleeve is affixed to the proximal end of the guidewire). Similarly, other modifications of the



above-described embodiment of the invention that are obvious to those of skill in the mechanical and guidewire/catheter arts are intended to be within the scope of the following claims.

5

10

15

20

25

30

35

Claims

1. An extendable guidewire assembly for use within a patient's vasculature comprising in combination:

5 (a) a guidewire having a distal end that is adapted to be fed into said vasculature and a tapered proximal end;

(b) an extension wire having a proximal end and a tapered distal end; and

10 (c) a polymeric sleeve having first and second ends and a lumen extending therebetween, said first end being fixedly attached concentrically about one of either the proximal end of the guidewire or the distal end of the extension wire, such that said one end extends partly  
15 through the lumen of the sleeve, said second end being adapted to receive the other of the proximal end of the guidewire or the distal end of the extension wire, said lumen having a diameter that is smaller than the diameter  
20 of the wire to which the sleeve is not fixedly attached and wherein said lumen expands radially when the sleeve is under axial compression and contracts radially when the sleeve is under axial tension.

2. The extendable guidewire assembly of  
25 claim 1 wherein the sleeve is fixedly attached about the distal end of the extension wire.

3. The extendable guidewire assembly of claim  
30 1 wherein the taper of the proximal end of the guidewire is a conical taper and the taper of the distal end of the extension wire is a conical taper.

4. The extendable guidewire assembly of claim  
35 1 wherein said one end to which the sleeve is fixedly

attached extends through greater than half the length of the sleeve lumen.

5           5. The extendable guidewire assembly of claim  
2 wherein the untapered diameter of the guidewire is  
about 0.3 to 0.4 mm, the untapered diameter of the  
extension wire is about 0.3 to 0.4 mm, and the diameter  
of the sleeve lumen is less than said untapered diameter  
of the guidewire.

10

6. The extendable guidewire assembly of claim  
5 wherein the length of the tapered end of the guidewire  
is 3 to 7 cm, the length of the tapered end of the  
extension wire is 3 to 7 cm and the length of the sleeve  
15 is 5 to 8 cm.

7. The extendable guidewire assembly of claim  
1 wherein the sleeve is made of polyimide and the wall  
thickness of the sleeve is 0.025 to 0.05 mm.

20

25

30

35

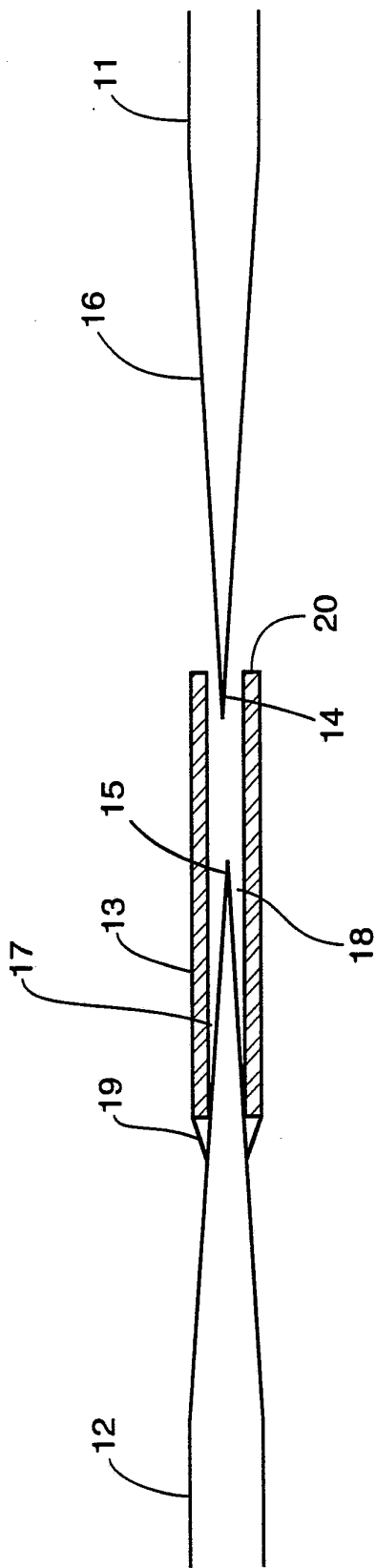

FIG. 1

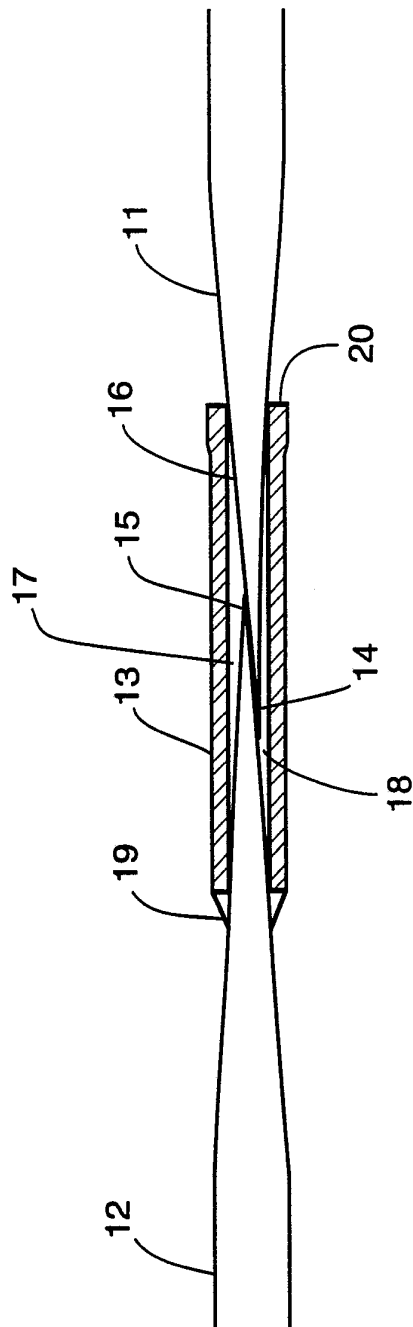

FIG. 2

INTERNATIONAL SEARCH REPORT

International application No.  
PCT/US92/07035

**A. CLASSIFICATION OF SUBJECT MATTER**

IPC(5) :A61M 25/00  
US CL :604/283; 128/772, 657

According to International Patent Classification (IPC) or to both national classification and IPC

**B. FIELDS SEARCHED**

Minimum documentation searched (classification system followed by classification symbols)

U.S. : 604/283; 128/772, 657; 604/95, 164, 166, 170, 171, 175, 905; 128/658

Documentation searched other than minimum documentation to the extent that such documents are included in the fields searched

Electronic data base consulted during the international search (name of data base and, where practicable, search terms used)  
none

**C. DOCUMENTS CONSIDERED TO BE RELEVANT**

Category*	Citation of document, with indication, where appropriate, of the relevant passages	Relevant to claim No.
Y	US, A, 4,875,489 (MESSNER ET AL.) 24 October 1989, see the entire document.	1-7
A	US, A, 4,922,923 (GAMBALE ET AL.) 08 May 1990, see the entire document.	
A	US, A, 5,031,636 (GAMBALE ET AL.) 16 July 1991, see the entire document.	

Further documents are listed in the continuation of Box C.  See patent family annex.

* Special categories of cited documents:	"T" later document published after the international filing date or priority date and not in conflict with the application but cited to understand the principle or theory underlying the invention
"A" document defining the general state of the art which is not considered to be part of particular relevance	"X" document of particular relevance; the claimed invention cannot be considered novel or cannot be considered to involve an inventive step when the document is taken alone
"E" earlier document published on or after the international filing date	"Y" document of particular relevance; the claimed invention cannot be considered to involve an inventive step when the document is combined with one or more other such documents, such combination being obvious to a person skilled in the art
"L" document which may throw doubts on priority claim(s) or which is cited to establish the publication date of another citation or other special reason (as specified)	"&" document member of the same patent family
"O" document referring to an oral disclosure, use, exhibition or other means	
"P" document published prior to the international filing date but later than the priority date claimed	

Date of the actual completion of the international search 28 SEPTEMBER 1992	Date of mailing of the international search report 01 DEC 1992
--	---

Name and mailing address of the ISA/  
Commissioner of Patents and Trademarks  
Box PCT  
Washington, D.C. 20231

Facsimile No. NOT APPLICABLE

Authorized officer *Andie Robinson*  
MANUEL ATONIO MENDEZ VSH

Telephone No. (703) 308-2221