

19



LE GOUVERNEMENT
DU GRAND-DUCHÉ DE LUXEMBOURG
Ministère de l'Économie

11

N° de publication :

LU504094

12

BREVET D'INVENTION**B1**

21

N° de dépôt: LU504094

51

Int. Cl.:
G01N 3/08, G01N 3/02

22

Date de dépôt: 27/04/2023

30

Priorité:
12/12/2022 CN 202211606503.4

72

Inventeur(s):
YU Weijian - China, PAN Bao - China

43

Date de mise à disposition du public: 30/10/2023

74

Mandataire(s):
LIN CHIEN Mon-Yin - 28340 Valdemoro, (Spain)

47

Date de délivrance: 30/10/2023

73

Titulaire(s):
HUNAN UNIVERSITY OF SCIENCE & TECHNOLOGY -
Xiangtan (China)

54

UNIAXIAL COMPRESSION ROCK MECHANICS TESTING MACHINE AND TESTING METHOD FOR NON-UNIFORM AXIAL LOADING.

57

This application provides a uniaxial compression rock mechanics testing machine and testing method for non-uniform axial loading. The machine comprises a frame, a pressurized platform, a power component, a test piece with a tilted surface on the top, a rigid outer shell embedded in the test piece, and a monitoring device. The power component exerts pressure on the rigid outer shell to uniformly squeeze the tilted surface of the test piece. Due to the height difference caused by the tilted surface, there is a strain gradient inside the test piece, resulting in axial non-uniform loading. The monitoring device is used to monitor the strain information during the testing process, which changes the existing situation where most rock mechanics tests are conducted on single test pieces or regular composite test pieces. The mechanical properties of rocks in deep wells under non-uniform high stress conditions are simulated, providing sufficient theoretical basis for deep roadway support technology. The testing machine has the advantages of simple structure, convenient operation, experimental data that is clear, easy to obtain and of reference value.

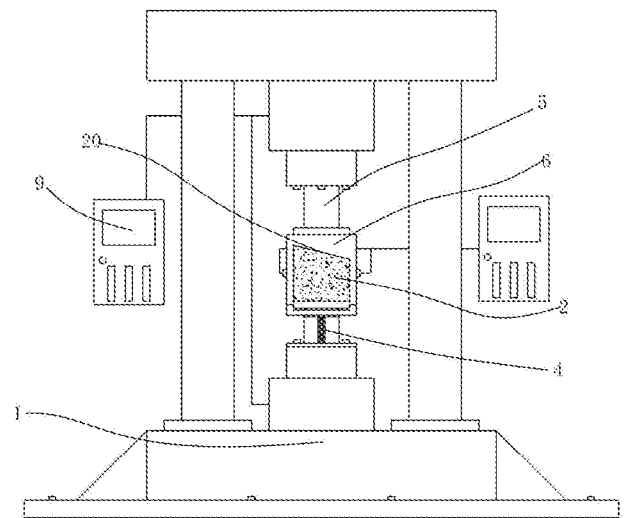

Fig. 1

UNIAXIAL COMPRESSION ROCK MECHANICS TESTING MACHINE AND TESTING METHOD FOR NON-UNIFORM AXIAL LOADING LU504094

FIELD OF TECHNOLOGY

This application relates to the technical field of rock mass mechanics testing, specifically, it involves a uniaxial compression rock mechanics testing machine and testing method for non-uniform axial loading.

BACKGROUND

In rock mass mining operations, as the mining depth increases, the support of deep roadway becomes increasingly difficult. To ensure the safety of mining operations in deep roadway during rock mass mining, the mining industry spends a lot of manpower and money on support engineering every year. The fundamental reason for the high difficulty of mining deep roadway is the lack of understanding of the mechanical properties of rocks in deep wells under high stress conditions. Therefore, the key to solving the difficulty of supporting deep roadway or complex roadway is to fully study the deformation and failure characteristics of rocks under stress conditions, and provide sufficient theoretical basis for deep roadway.

Most of the existing rock mechanics experiments are conducted on single or regular composite test pieces. The constitutive relationship between load and deformation of rock test pieces is studied by changing loading rates, dynamic/static loading methods, or temperature. However, the stress release of surrounding rock near the roadway after the excavation of rock mass in mining operations leads to local uneven stress in the rock mass. At the same time, the load on both sides of the roadway has a significant non-uniform characteristic. While the existing rock mechanics tests are based on loading rock test pieces as a whole, which cannot achieve non-uniform loading on a single intact rock. Therefore, there is an urgent need for a uniaxial rock mechanics testing machine that can apply non-uniform axial loads to the test pieces.

SUMMARY

To solve the technical problem that it is impossible to realize non-uniform loading of a single complete rock when the existing rock mechanics tests use rock test pieces as a whole for loading due to the lack of understanding of the mechanical properties of rocks in deep wells under high stress conditions in the existing ore opening industry, a uniaxial compression rock mechanics testing machine and testing method for non-uniform axial loading is proposed.

This application adopts the following scheme, that is, a uniaxial compression rock mechanics testing machine for non-uniform axial loading, comprising a frame equipped with a pressurized platform for placing test pieces, and a power component on the frame located on the upper side of the pressurized platform, an inclined surface is provided on the top surface of the test piece, the pressurized platform is provided with a rigid outer shell which is used to nest the test piece, the power component is used to uniformly compress the inclined surface by applying pressure to the rigid outer shell. There is a strain gradient in the test piece due to the height difference of the inclined plane, resulting in an axial non-uniform load. The inner wall of the

rigid outer shell is provided with a monitoring device for monitoring the stress information of the test piece.

LU504094

Preferably, both sides of the bottom of the rigid outer shell abut on the pressurized platform. When the power component presses the rigid outer shell downward, the displacement on both sides of the rigid outer shell can be equal, so that there is a strain gradient inside the test piece during uniform compression of the rigid outer shell due to the height difference of the inclined plane, resulting in axial non-uniform load.

Preferably, the rigid outer shell is provided with a inclined pressure surface matching the inclined surface.

Preferably, the monitoring device comprises a stress sensor set on the contact surface between the rigid outer shell and the inclined surface, and an acoustic emission probe set on both sides of the inner wall of the rigid outer shell. The stress sensor and the acoustic emission probe are electrically connected to the monitoring unit.

Preferably, the rigid outer shell is made of a rigid material, and the rigid outer shell does not produce plastic deformation on the contact surface between the rigid outer shell and the inclined surface during the uniform compression process of the power component.

Preferably, the pressured platform comprises a base mounted on the frame, a balance support plate mounted on the upper part of the base, a track rod mounted between the balance support plate and the base, and a pad mounted on the balance support plate. The two sides of the balance support plate abut on the two sides of the rigid outer shell. When the rigid outer shell is under uniform pressure from the power component, the balance support plate can move in the axial direction of the track rod.

Preferably, the balance support plate is set on the track rod through a horizontal clamp, and a spring slot is provided in the middle of the track rod for accommodating springs. When the rigid outer shell is under uniform pressure from the power component, the rigid outer shell evenly compresses the test piece. The elastic force of the spring can ensure that the balance support plate is evenly displaced along the track rod, ensuring equal displacement on both sides of the rigid outer shell.

Preferably, the middle of the horizontal clamp is provided with a clamp block that can be connected to the spring slot and slide, and both sides of the balance support plate are provided with sliding slots that can be connected to the clamp block and slide.

Preferably, the horizontal clamp clamps the balance support plate between the horizontal clamps by placing the clamp block in the sliding slot, and the horizontal clamp clamps the balance support plate on the track rod by pressing the spring to place the clamp block in the spring slot.

Another purpose of this application is to provide a uniaxial compression rock mechanics testing machine and testing method for non-uniform axial loading. To use uniaxial compression rock mechanics testing machine and testing method for non-uniform axial loading, the test method comprises the following steps:

Step 1: Place the test piece on the pressurized platform;

LU504094

Step 2: Nest the rigid outer shell onto the test piece, and make it in contact with the pressurized platform;

Step 3: Start the power component and uniformly compress the rigid outer shell until it tightly contacts the pressurized platform, thus achieving preloading;

Step 4: Start loading with the power component and use the monitoring device to monitor the relevant data of the test piece during the static loading process, completing the static loading test.

This application provides a uniaxial compression rock mechanics testing machine and testing method for non-uniform axial loading, comprising a frame, a pressurized platform, a power component, a test piece with an inclined surface on the top, a rigid outer shell nested in the test piece, and a monitoring device. By applying pressure to the rigid outer shell with the power component, the inclined surface of the test piece is uniformly compressed by the rigid outer shell, which leads to the internal strain gradient of the test piece due to the height difference caused by the inclined surface, resulting in non-uniform axial loading inside the test piece. Then, by monitoring the strain information during the testing process with the monitoring device, the situation that most of the existing rock mechanics tests are performed on single test piece or regular composite test pieces is changed, moreover, it simulates the mechanical properties of rocks under non-uniform high stress conditions in deep wells, providing sufficient theoretical basis for deep well roadway support technology. It has the advantages of simple structure, convenient test operation, concise and accessible test data, and reference significance.

BRIEF DESCRIPTION OF THE DRAWINGS

To provide a clearer illustration of the technical solution in the present example, a brief introduction is given below on the drawings that need to be used in the description of the example.

Fig. 1 is the front view of the uniaxial compression rock mechanics testing machine with non-uniform axial load in the present application.

Fig. 2 is a schematic diagram of the structure of the rigid outer shell in the present application.

Fig. 3 is another perspective view of the structure of the rigid outer shell in the present application.

Fig. 4 is a schematic diagram of the structure of the pressurized platform in the present application.

Fig. 5 is a schematic diagram of the structure of the pressurized platform after the decomposed balance plate in the present application.

DESCRIPTION OF THE EMBODIMENTS

As shown in Fig. 1-Fig. 5, a uniaxial compression rock mechanics testing machine and testing method for non-uniform axial loading comprises a frame 1, the said frame 1 is provided

with a pressurized platform 4 for placing the test piece 2. A power component 5 is located on the upper side of the pressurized platform 4 of the frame 1. The top surface of the test piece 2 is provided with an inclined surface 20. A rigid outer shell 6 which nests the test piece 2 is provided on the pressurized platform 4. The power component 5 is used to uniformly squeeze the inclined surface 20 by applying pressure to the rigid outer shell 6, so that there is a strain gradient inside the test piece 2 due to the height difference of the inclined surface 20, thereby generating axial non-uniform loads. The inner wall of the rigid outer shell 6 is set with a monitoring device 3 for monitoring the stress information of the test piece 2. tU504094

The present application provides a uniaxial compression rock mechanics testing machine and testing method for non-uniform axial loading, comprising a frame, a pressurized platform, a power component, a test piece with an inclined surface on the top, a rigid outer shell nested in the test piece, and a monitoring device. The power component applies pressure to the rigid outer shell, as a result, the rigid outer shell uniformly squeezes the inclined surface of the test piece, causing a strain gradient inside the test piece due to the height difference of the inclined surface, which in turn generates axial non-uniform loads inside the test piece. Then the monitoring device is used to monitor the strain information during the test process, which changes the situation where most existing rock mechanics tests are performed on single test piece or regular composite test pieces. Furthermore, it simulates the mechanical characteristics of rocks under non-uniform high stress conditions in deep wells, which provides sufficient theoretical basis for deep well roadway support technology. It has the advantages of simple structure, convenient test operation, concise and easily obtainable test data, and reference significance.

Preferably, the bottom sides of the rigid outer shell 6 are in contact with the pressurized platform 4, and when the power component 5 presses down on the rigid outer shell 6, the displacement on both sides of the rigid outer shell 6 is equal, so that the test piece 2 is uniformly compressed by the rigid outer shell 6 due to the height difference of the inclined surface 20, and a strain gradient is generated inside the test piece 2, thereby generating axial non-uniform loads.

During the actual test, the test piece 2 is placed on the pressurized platform 4, and the rigid outer shell 6 is nested on the test piece 2. Stress sensor 7 and acoustic emission probe 8 are embedded in the inner wall of the rigid outer shell 6, which can be directly used in the test. At the same time, both sides of the rigid outer shell 2 are just in contact with the two wings of the pressurized platform 4, ensuring that when the power component 5 applies a load to the rigid outer shell, during the process of applying pressure to the rigid outer shell 6 through the power component 5, the displacement of the two wings of the pressurized platform 4 is equal. Therefore, the strain at different height sections of the test piece with inclined surface 20 near the power component 5 is different, forming non-uniformly distributed axial loads. According to the stress-strain curve of rocks, it is known that the stress distribution between sections at different height is different, which changes the situation where most existing rock mechanics tests are performed on single test piece or regular composite test pieces, thereby providing sufficient theoretical basis for deep well roadway support technology. It has the advantages of simple structure, convenient test operation, concise and easily obtainable test data, and reference significance.

Preferably, there is an inclined pressure surface 60 that matches the inclined surface 20 on the rigid outer shell 6;

During the actual test process, the test piece 2 is placed on the pressurized platform 4, and the rigid outer shell 6 is nested on the test piece 2. The inclined pressure surface 60 on the rigid outer shell 6 is embedded with the stress sensor 7. Acoustic emission probes 8 are embedded in both sides of the inner wall of the rigid outer shell 6, at the same time, both sides of the rigid outer shell 2 are just in contact with the two wings of the pressurized platform 4, ensuring that when the power component 5 applies a load to the rigid outer shell, during the process of applying pressure to the rigid outer shell 6 by the power component 5, the inclined pressure surface 60 uniformly compresses the inclined surface 20. The displacement of the two wings of the pressurized platform 4 is equal, so that the strain at the sections with different height of the test piece with inclined surface 20 near the power component 5 is different, consequently, non-uniformly distributed axial loads are formed. According to the stress-strain curve of rocks, it is known that the stress distribution between sections at different heights is different, which changes the situation where most existing rock mechanics tests are performed on single test piece or regular composite test pieces, thereby providing sufficient theoretical basis for deep well roadway support technology. It has the advantages of simple structure, convenient test operation, concise and easily obtainable test data, and reference significance.

Preferably, the monitoring device 3 comprises stress sensors 7 located on the contact surface between the rigid outer shell 6 and the inclined surface 20, and acoustic emission probes 8 located on both sides of the inner wall of the rigid outer shell 6. The stress sensors 7 and acoustic emission probes 8 are electrically connected to the monitoring unit 9;

During the actual testing process, the test piece 2 is placed on the pressurized platform 4, and the rigid outer shell 6 is set on the test piece 2. The inner wall of the rigid outer shell 6 is embedded with stress sensors 7 and acoustic emission probes 8. The stress sensors 7 and acoustic emission probes 8 are electrically connected to the monitoring unit 9. The changes in stress distribution during the testing process can be directly monitored, and there is no need to install sensors on the surface of the test piece 2; at the same time, the two sides of the rigid outer shell 2 are just in contact with the two wings of the pressurized platform 4, ensuring that when the power component 5 applies a load to the rigid outer shell, the displacement downwards of the two wings of the pressurized platform 4 is equal. The test piece 2 produces a strain difference, forming a non-uniformly distributed axial load. During the process of applying pressure to the rigid outer shell 6 through the power component 5, the displacement downwards of the two wings of the pressurized platform 4 is equal. Therefore, the strain at the sections with different height of the test piece with inclined surface 20 near the power component 5 is different. According to the stress-strain curve of rocks, it is known that the stress distribution between sections at different heights is different, which changes the situation where most existing rock mechanics tests are performed on single test piece or regular composite test pieces, thereby providing sufficient theoretical basis for deep well roadway support technology. It has the advantages of simple structure, convenient test operation, concise and easily obtainable test data, and reference significance.

Preferably, the rigid outer shell 6 is made of a rigid material, and during the uniform compression process of the power component 5, the contact surface of the rigid outer shell 6 with the inclined surface 20 does not undergo plastic deformation.

In the actual test process, the rigid outer shell 6 is made of rigid material, and the deformation of the inclined pressing surface 60 during the uniform compression of the inclined surface 20 is extremely small, which can be ignored. This can prevent the additional stress due to deformation between the inclined pressure surface 60 and the inclined surface 20 from affecting the accuracy of the test data, and change the situation where most of the existing rock mechanics tests are performed on single test piece or regular composite test pieces. It provides a sufficient theoretical basis for deep mine roadway support technology, and has the advantages of simple structure, convenient test operation, concise and readily available test data, and reference significance.

Preferably, the pressurized platform 4 comprises a base 40 located on the frame 1, a balance support plate 41 located on the upper part of the base 40, a track rod 42 located between the balance support plate 41 and the base 40, and a pad 46 located on the balance support plate 41. The two sides of the balance support plate 41 are in contact with the two sides of the rigid outer shell 6. When the rigid outer shell 6 is subjected to uniform pressure from the power component 5, the balance support plate 41 can move along the axial direction of the track rod 42;

In the actual test process, the test piece 2 is placed on the pad 46 of the balance support plate 41, and the rigid outer shell 6 is nested on the test piece 2. Stress sensors 7 and acoustic emission probes 8 are embedded in the inner wall of the rigid outer shell 6, which can be directly used in the test without installing sensors on the surface of the test piece 2. At the same time, the two sides of the rigid outer shell 6 are in contact with the two wings of the balance support plate 41, which ensures that when the power component 5 applies a load to the rigid outer shell, the two wings of the balance support plate 46 move uniformly towards the base 40 direction along the track rod 42 under the action of the rigid outer shell. Due to the existence of the inclined surface 20, the test piece 2 produces strain difference, resulting in non-uniformly distributed axial load, during the process of applying pressure to the rigid outer shell 6 by the power component 5, the displacement of the two wings of the pressurized platform 4 towards the base 40 is equal. Therefore, the strain at the sections with different height of the test piece with inclined surface 20 near the power component 5 is different. According to the stress-strain curve of rocks, it is known that the stress distribution between sections at different heights is different, which changes the situation where most existing rock mechanics tests are performed on single test piece or regular composite test pieces, thereby providing sufficient theoretical basis for deep well roadway support technology. It has the advantages of simple structure, convenient test operation, concise and easily obtainable test data, and reference significance.

Preferably, the balance support plate 41 is set on the track rod 42 through a horizontal clamp 43, and a spring slot 45 is provided in the middle of the track rod 42 to accommodate the spring 44. When the rigid outer shell 6 is under uniform pressure from the power member 5, the rigid outer shell 6 evenly compresses the test piece 2, and the elastic force of the spring 44 can ensure that the balance support plate 41 is uniformly displaced along the track rod 42, and further ensure equal displacement on both sides of the rigid outer shell 6; Preferably, the middle of the horizontal clamp 43 is provided with a clamp block 430 that can be connected to the spring slot 45 and slide, and both sides of the balance support plate 41 are provided with sliding slots 410 that can be connected to the clamp block 430 and slide; More preferably, the horizontal clamp 43 clamps the balance support plate 41 between the horizontal clamps 43 by placing the clamp block 430 in the sliding slot 410, and the horizontal clamp 43 presses the spring 44 to place the

clamp block 430 in the spring slot 45, so that the balance support plate 41 is placed on the track rod 42. During actual test, pressure is applied to the rigid outer shell 6 through the power component 5 to drive the rigid outer shell 6 to cling to the balance support plate 41, and thereby displacing it along the track rod 42 towards the base 40. The spring 44 in the spring slot 45 on the track rod 42 can ensure that the balance support plate 41 moves slowly and evenly along the track rod 42 towards the bottom plate 40, which is conducive to a clear analysis of the internal stress situation of the test piece 2. Using the horizontal clamp 43 to install the balance support plate 41 on the track rod 42 through the coordination of the clamp block 430 with the sliding slot 410 and the spring slot 45. It has the advantages of simple structure, convenient test operation, concise and accessible test data, and reference significance. LU504094

This application also provides a uniaxial compression rock mechanics test method for non-uniform axial loading. Using the uniaxial compression rock mechanics testing machine with non-uniform axial loading, the test method comprises the following steps:

Step 1: Place the test piece 2 on the pressurized platform 4;

Step 2: Nest the rigid outer shell 6 on the test piece 2, and make the rigid outer shell 6 attach to the pressurized platform 4;

Step 3: Start the power component 5 and evenly press the rigid outer shell 6 until the rigid outer shell 6 is in close contact with the pressurized platform 4, thereby achieving preloading;

Step 4: The power component 5 starts loading, and the stress sensor 7 and acoustic emission probe 8 are used to monitor the relevant data of the test piece during the static loading process, which is recorded in the monitoring unit 9, thereby completing the static loading test.

In the actual test process, firstly, place the test piece 2 on the pad 46 on the balance support plate 41, and then nest the rigid outer shell 6 on the test piece 2. The inner wall of the rigid outer shell 6 is embedded with a stress sensor 7 and an acoustic emission probe 8 connected to the monitoring unit 9, which can monitor the stress condition of the test piece 2. This testing machine can be directly put into test use, and there is no need to install a sensor on the surface of the test piece 2; At the same time, both sides of the rigid outer shell 2 are just in contact with the two wings of the balance support plate 41 to ensure that when the power component 5 applies a load to the rigid outer shell 6, the two wings of the balance support plate 46 are uniformly displaced towards the base 40 along the track rod 42 with the help of the spring 44 and under the action of the rigid outer shell 6. The test piece 2 produces a strain difference due to the height difference of the inclined surface 20, and a non-uniformly distributed axial load is formed under compression of the inclined pressure surface 60 of the rigid outer shell 6. During the process of applying pressure to the rigid outer shell 6 through the power component 5, the downward displacement of the two wings of the pressurized platform 4 is equal. Therefore, the strain at the sections with different height of the test piece with inclined surface 20 near the power component 5 is different. According to the stress-strain curve of rocks, it is known that the stress distribution between sections at different heights is different, which changes the situation where most existing rock mechanics tests are performed on single test piece or regular composite test pieces, thereby providing sufficient theoretical basis for deep well roadway support technology. It has the advantages of simple structure, convenient test operation, concise and easily obtainable test data, and reference significance.

The above are only some preferred examples of the present invention, which are not intended to limit the invention. Any modifications, equivalent substitutions, and improvements made within the spirit and principles of the present invention should be included in the scope of protection of the present invention. LU504094

1. A uniaxial compression rock mechanics testing machine for non-uniform axial loading comprising a frame (1), characterized in that, the frame comprises a pressurized platform (4) for placing the test piece (2) on the frame (1), and a power component (5) is located on the upper side of the pressurized platform (4) of the frame (1), the test piece (2) is provided with an inclined surface (20) on its top surface, a rigid outer shell (6) that nests the test piece (2) is provided on the pressurized platform (4), the power component (5) applies pressure to the rigid outer shell (6) to uniformly squeeze the inclined surface (20) of the test piece (2), resulting in a strain gradient inside the test piece (2) due to the height difference of the inclined surface (20), which leads to non-uniform axial loading, a monitoring device (3) for monitoring stress information of the test piece (2) is provided on the inner wall of the rigid outer shell (6).

2. The uniaxial compression rock mechanics testing machine for non-uniform axial loading according to claim 1, characterized in that, the bottom sides of the rigid outer shell (6) abut against the pressurized platform (4), and the displacement of the rigid outer shell (6) on both sides is equal when the power component (5) presses down on the rigid outer shell (6), as a result, during the process of uniformly compressing on the test piece (2) by the rigid outer shell (6), there exists a strain gradient inside the test piece (2) due to the height difference of the inclined surface (20), which leads to non-uniform axial loading.

3. The uniaxial compression rock mechanics testing machine for non-uniform axial loading according to claim 2, characterized in that, the rigid outer shell (6) is provided with an inclined pressing surface (60) that matches the inclined surface (20).

4. The uniaxial compression rock mechanics testing machine for non-uniform axial loading according to claim 1, characterized in that, a monitoring device (3) comprises a stress sensor (7) in contact with the inclined surface (20), which is provided on the rigid outer shell (6), and an acoustic emission probes (8) provided on both sides of the inner wall of the rigid outer shell (6), and the stress sensor (7) and the acoustic emission probes (8) are electrically connected to the monitoring unit (9).

5. The uniaxial compression rock mechanics testing machine for non-uniform axial loading according to claim 1, characterized in that, the outer shell (6) is made of rigid material, and the rigid outer shell (6) does not undergo plastic deformation on its contact surface with the inclined surface (20) during the uniform compression process by the power component (5).

6. The uniaxial compression rock mechanics testing machine for non-uniform axial loading according to claim 1, characterized in that, the pressurized platform (4) comprises a base (40) located on the frame (1), a balance support plate (41) located on the upper part of the base (40), and a pad (46) located on the balance support plate (41), the balance support plate (41) is in contact with the two sides of the rigid outer shell (6), and after the rigid outer shell (6) is uniformly compressed by the power component (5), the balance support plate (41) can move along the axial direction of the track rod (42).

7. The uniaxial compression rock mechanics testing machine for non-uniform axial loading according to claim 6, characterized in that, the balance support plate (41) is arranged on the track rod (42) through a horizontal clamp (43), and a spring slot (45) is provided in the middle of the

track rod (42) to accommodate the spring (44), when the rigid outer shell (6) is subjected to uniform pressure from the power component (5), the rigid outer shell (6) uniformly compresses the test piece (2), and the elastic force of the spring (44) can ensure that the balance support plate (41) uniformly displaces along the track rod (42), ensuring equal displacement on both sides of the rigid outer shell (6). LU504094

8. The uniaxial compression rock mechanics testing machine for non-uniform axial loading according to claim 7, characterized in that, the middle of the horizontal clamp (43) is provided with a clamp block (430) that can be connected to the spring slot (45) and slide, and both sides of the balance support plate (41) are provided with sliding slots (410) that can be connected to the clamp block (430) and slide.

9. The uniaxial compression rock mechanics testing machine for non-uniform axial loading according to claim 8, characterized in that, the horizontal clamp (43) clamps the balance support plate (41) between the horizontal clamps (43) by placing the clamp block (430) in the sliding slot (410), and the horizontal clamp (43) presses the spring (44) to place the clamp block (430) in the spring slot (45) so that the balance support plate (41) is placed on the track rod (42).

10. A uniaxial compression rock mechanics testing method for non-uniform axial loading, characterized in that, it adopts the uniaxial compression rock mechanics testing machine and testing method for non-uniform axial loading according to any one of claims 1- 9 and the testing method comprises the following steps:

Step 1: Install the test piece (2) on the pressurized platform (4);

Step 2: Nest the rigid outer shell (6) onto the test piece (2) and fit the rigid outer shell (6) to the pressurized platform (4);

Step 3: Start the power component (5) and evenly press the rigid outer shell (6) until the rigid outer shell (6) completely abuts the pressurized platform (4), achieving preloading;

Step 4: The power component (5) starts loading, and the monitoring device (3) is used to monitor the relevant data of the test piece (2) during the static loading process, thereby completing the static loading test.

1. Ein gesteinsmechanisches Prüfgerät mit einachsiger Kompression für ungleichmäßige axiale Belastung, das ein Gestell (1) umfasst, dadurch gekennzeichnet, dass das Gestell (1) mit einem Drucktisch (4) zur Aufstellung eines Prüfstücks (2) versehen ist, wobei das Gestell (1) mit einem Antriebselement (5) an der Oberseite des Drucktisches (4) versehen ist, wobei das Prüfstück (2) mit einer geneigten Fläche (20) an der Oberseite versehen ist, wobei der Drucktisch (4) mit einem starren Außengehäuse (6) zum Einbetten des Prüfstücks (2) versehen ist, wobei das Antriebselement (5) dazu verwendet wird, Druck auf das starre Außengehäuse (6) auszuüben und dadurch die geneigte Fläche (20) gleichmäßig zusammenzudrücken, so dass aufgrund des Höhenunterschieds der geneigten Fläche (20) ein Dehnungsgradient im Inneren des Prüfstücks (2) vorhanden ist und dadurch eine ungleichmäßige axiale Belastung erzeugt wird, wobei das starre Außengehäuse (6) mit einer Überwachungs Vorrichtung (3) an der Innenwand zur Überwachung der Spannungsinformationen des Prüfstücks (2) versehen ist.

2. Das gesteinsmechanisches Prüfgerät mit einachsiger Kompression für ungleichmäßige axiale Belastung nach Anspruch 1, dadurch gekennzeichnet, dass das starre Außengehäuse (6) an beiden Seiten des Bodens an dem Drucktisch (4) befestigt ist, wenn das Antriebselement (5) auf das starre Außengehäuse (6) nach unten drückt, so dass eine gleiche Verschiebung auf beiden Seiten des starren Außengehäuses (6) vorliegt und das Prüfstück (2) aufgrund des Höhenunterschieds der geneigten Fläche (20) einer ungleichmäßigen axialen Belastung ausgesetzt wird, die während des gleichmäßigen Zusammendrückens des starren Außengehäuses (6) durchs Vorhandensein des Dehnungsgradienten innerhalb des Prüfstücks (2) entsteht.

3. Das gesteinsmechanisches Prüfgerät mit einachsiger Kompression für ungleichmäßige axiale Belastung nach Anspruch 2, dadurch gekennzeichnet, dass das starre Außengehäuse (6) mit einer geneigten Druckfläche (60) versehen ist, die der geneigten Fläche (20) entspricht.

4. Das gesteinsmechanisches Prüfgerät mit einachsiger Kompression für ungleichmäßige axiale Belastung nach Anspruch 1, dadurch gekennzeichnet, dass die Überwachungs Vorrichtung (3) einen Spannungssensor (7), der an der Kontaktfläche des starren Außengehäuses (6) und der geneigten Fläche (20) angeordnet ist, und Schallemissionssonden (8) umfasst, die an beiden Seiten der Innenwand des starren Außengehäuses (6) angeordnet sind, wobei der Spannungssensor (7) und die Schallemissionssonden (8) elektrisch mit der Überwachungs Vorrichtung (9) verbunden sind.

5. Das gesteinsmechanisches Prüfgerät mit einachsiger Kompression für ungleichmäßige axiale Belastung nach Anspruch 1, dadurch gekennzeichnet, dass das starre Außengehäuse (6) von einem starren Material ist, wobei die Kontaktfläche vom starren Außengehäuse (6) mit der geneigten Fläche (20) während der gleichmäßigen Kompression des Antriebselements (5) frei von plastischer Verformung ist.

6. Das gesteinsmechanisches Prüfgerät mit einachsiger Kompression für ungleichmäßige axiale Belastung nach Anspruch 1, dadurch gekennzeichnet, dass der Drucktisch (4) eine auf dem Gestell (1) angeordnete Grundplatte (40), eine auf dem Oberteil der Grundplatte (40) angeordnete Ausgleichsträgerpalette (41), eine zwischen der Ausgleichsträgerpalette (41) und der Grundplatte (40) angeordnete Spurstange (42) und ein auf der Ausgleichsträgerpalette (41) angeordnetes Kissen (46) umfasst, wobei beide Seiten der Ausgleichsträgerpalette (41) an dem starren Gehäuse (6) anliegen, wobei das starre Gehäuse (6) durch das Antriebselement (5) einem

gleichmäßigen Druck ausgesetzt ist, wobei die Ausgleichsträgerpalette (41) in der axialen Richtung der Spurstange (42) bewegen kann. LU504094

7. Das gesteinsmechanisches Prüfgerät mit einachsiger Kompression für ungleichmäßige axiale Belastung nach Anspruch 6, dadurch gekennzeichnet, dass die Ausgleichsträgerpalette (41) mittels einer horizontalen Klemmvorrichtung (43) auf die Spurstange (42) gesetzt wird, wobei die Spurstange (42) mit einem Federschlitz (45) in der Mitte zur Aufnahme einer Feder (44) versehen ist; wenn das starre Außengehäuse (6) einem gleichmäßigen Druck vom Antriebselement (5) ausgesetzt wird, drückt das starre Außengehäuse (6) das Prüfstück (2) gleichmäßig, so dass die Federkraft der Feder (44) eine gleichmäßige Verschiebung der Ausgleichsträgerpalette (41) entlang der Spurstange (42) gewährleistet, wodurch eine gleichmäßige Verschiebung auf beiden Seiten des starren Außengehäuses (6) gewährleistet wird.

8. Das gesteinsmechanisches Prüfgerät mit einachsiger Kompression für ungleichmäßige axiale Belastung nach Anspruch 7, dadurch gekennzeichnet, dass die horizontale Klemmvorrichtung (43) in der Mitte mit einem Klemmblock (430) versehen ist, der mit dem Federschlitz (45) gleitend verbindet, und dass die Ausgleichsträgerpalette (41) auf beiden Seiten mit Gleitschlitz (410) versehen ist, die mit dem Klemmblock (430) gleitend verbinden.

9. Das gesteinsmechanisches Prüfgerät mit einachsiger Kompression für ungleichmäßige axiale Belastung nach Anspruch 8, dadurch gekennzeichnet, dass die horizontale Klemmvorrichtung (43) durchs Einsetzen des Klemmblocks (430) in den Gleitschlitz (410) die Ausgleichsträgerpalette (41) zwischen der horizontalen Klemmvorrichtung (43) befestigt, wobei die horizontale Klemmvorrichtung (43) durchs Herunterdrücken der Feder (44) den Klemmblock (430) in den Federschlitz (45) eingesetzt, so dass die Ausgleichsträgerpalette (41) auf die Spurstange (42) gesetzt wird.

10. Ein Verfahren zur gesteinsmechanischen Prüfung mit einachsiger Kompression für ungleichmäßige axiale Belastung, dadurch gekennzeichnet, dass ein gesteinsmechanisches Prüfgerät mit einachsiger Kompression für ungleichmäßige axiale Belastung nach einem der Ansprüche 1 bis 9 verwendet wird, wobei das Prüfverfahren die folgenden Schritte umfasst:

Schritt 1: Das Prüfstück (2) auf den Drucktisch (4) platzieren;

Schritt 2: Das starre Gehäuse (6) auf das Prüfstück (2) einbetten, damit das starre Gehäuse (6) am Drucktisch (4) liegt;

Schritt 3: Das Antriebselement (5) aktivieren und das starre Gehäuse (6) bis zu dem Punkt gleichmäßig zusammendrücken, an dem das starre Gehäuse (6) vollständig und fest gegen den Drucktisch (4) gepresst ist, um eine Vorspannung zu erreichen;

Schritt 4: Dann beginnt die Belastung des Antriebselements (5) und die Daten über das Prüfstück (2) während der statischen Belastung werden mit Hilfe der Überwachungsvorrichtung (3) überwacht, d. h. die statische Belastungsprüfung ist abgeschlossen.

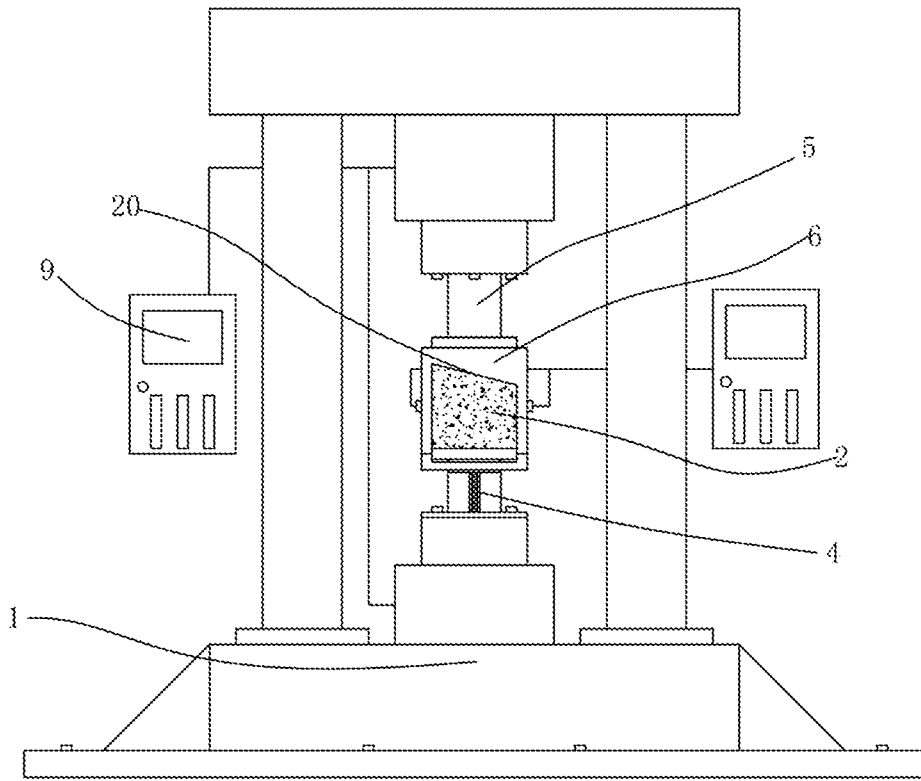

Fig. 1

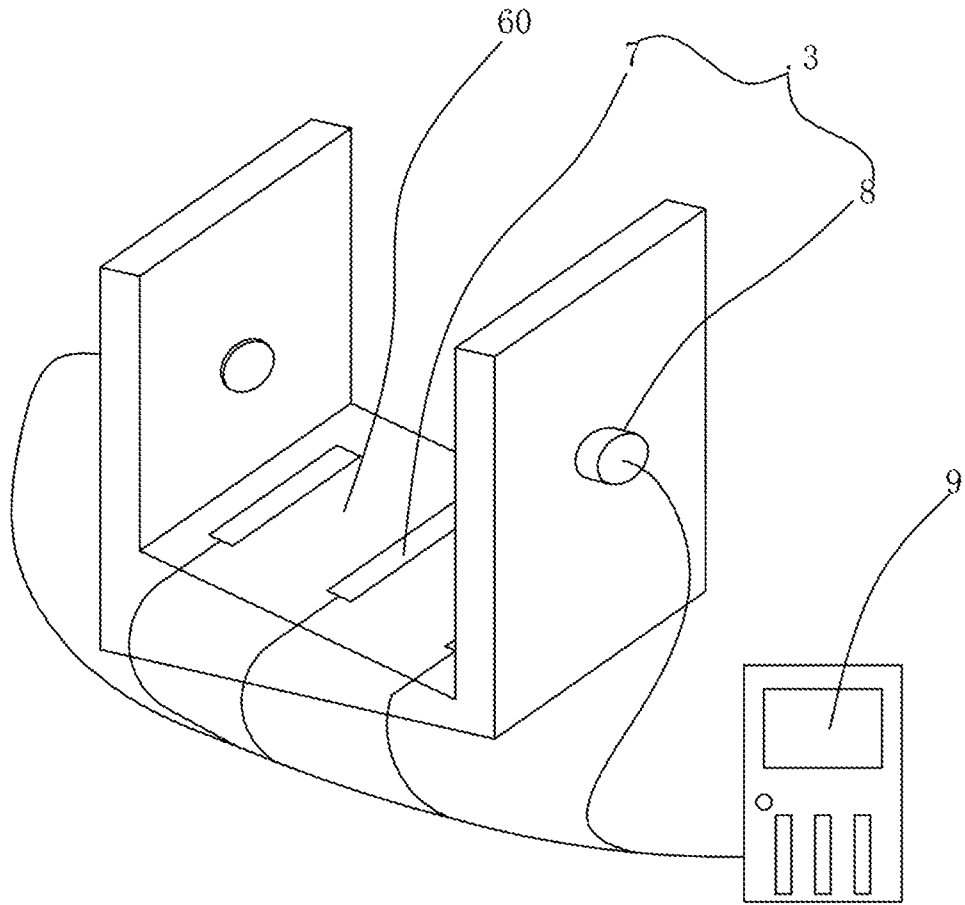

Fig. 2

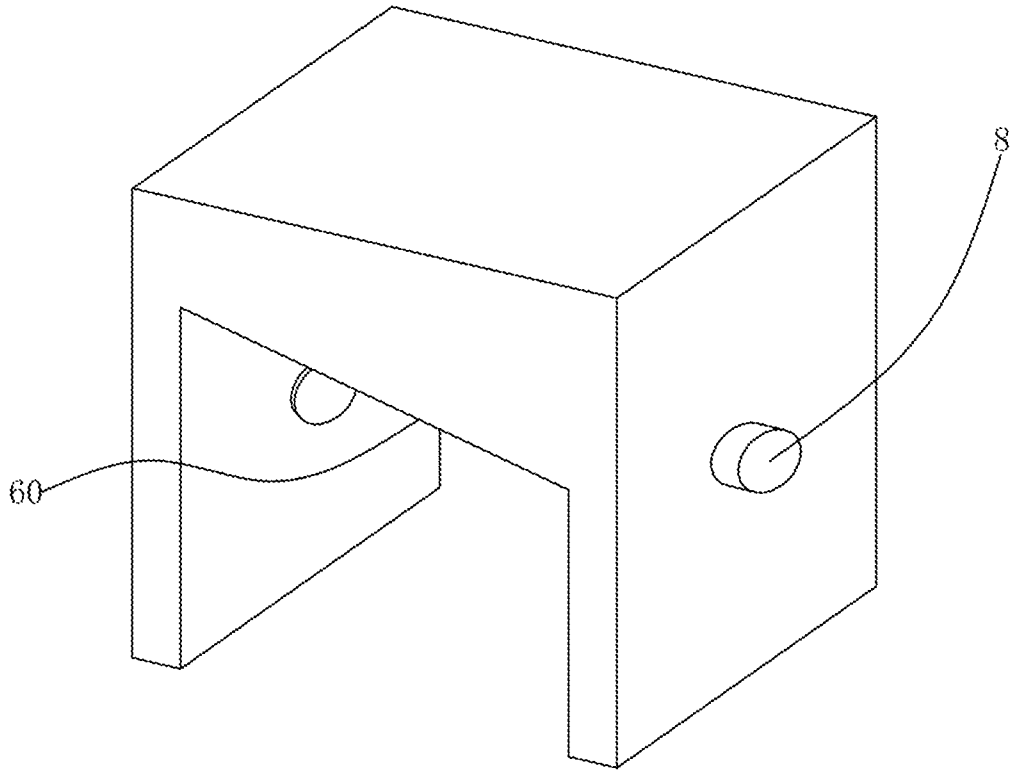

Fig. 3

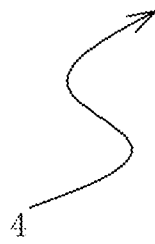
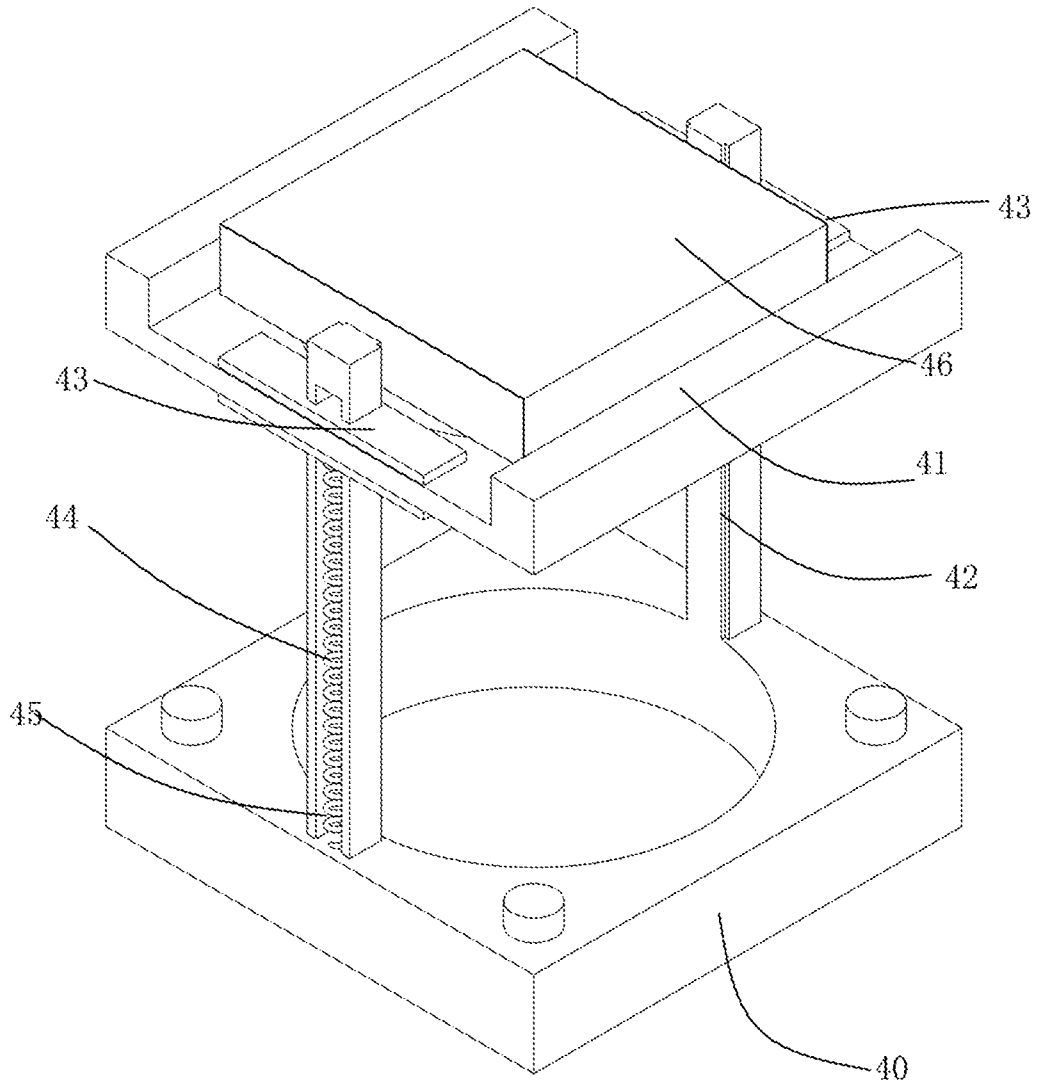

Fig. 4

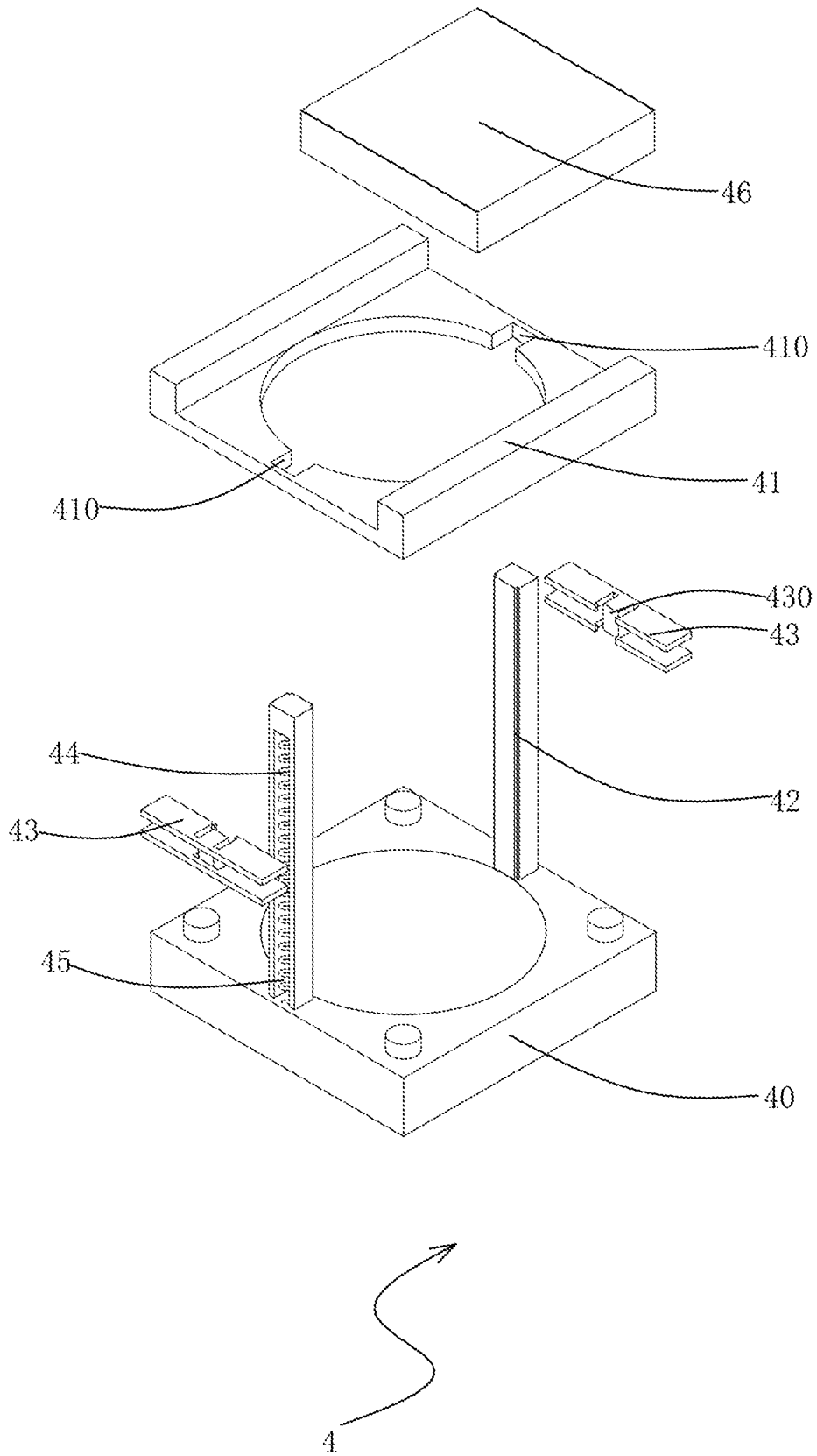

Fig. 5