

(19) World Intellectual Property Organization  
International Bureau



(43) International Publication Date  
5 January 2012 (05.01.2012)

(10) International Publication Number  
**WO 2012/002860 A1**

- (51) **International Patent Classification:**  
**B25F 5/02** (2006.01)      **A01G 3/06** (2006.01)  
**A01G 3/053** (2006.01)      **B23D 49/12** (2006.01)
- (21) **International Application Number:**  
PCT/SE20 10/050765
- (22) **International Filing Date:**  
2 July 2010 (02.07.2010)
- (25) **Filing Language:** English
- (26) **Publication Language:** English
- (71) **Applicant (for all designated States except US):** **HUSQ-VARNA AB** [SE/SE]; Drottninggatan 2, S-561 82 Huskvarna (SE).
- (72) **Inventors; and**
- (75) **Inventors/Applicants (for US only):** **MARTINSSON, Par** [SE/SE]; Orrvagen 4, SE-556 26 Jonkoping (SE). **BJÖRNLINGER, Johan** [SE/SE]; Kittendorffsgata 20, S-561 51 Huskvarna (SE). **BERGQUIST, Oskar** [SE/SE]; Skolgatan 30A, S-561 35 Huskvarna (SE).
- (74) **Agent:** **ANDERSSON, Jonas**; Huskvarna AB, Intellectual Property- EM-LPH, Drottninggatan 2, SE-561 82 Huskvarna (SE).

- (81) **Designated States (unless otherwise indicated, for every kind of national protection available):** AE, AG, AL, AM, AO, AT, AU, AZ, BA, BB, BG, BH, BR, BW, BY, BZ, CA, CH, CL, CN, CO, CR, CU, CZ, DE, DK, DM, DO, DZ, EC, EE, EG, ES, FI, GB, GD, GE, GH, GM, GT, HN, HR, HU, ID, IL, IN, IS, JP, KE, KG, KM, KN, KP, KR, KZ, LA, LC, LK, LR, LS, LT, LU, LY, MA, MD, ME, MG, MK, MN, MW, MX, MY, MZ, NA, NG, NI, NO, NZ, OM, PE, PG, PH, PL, PT, RO, RS, RU, SC, SD, SE, SG, SK, SL, SM, ST, SV, SY, TH, TJ, TM, TN, TR, TT, TZ, UA, UG, US, UZ, VC, VN, ZA, ZM, ZW.
- (84) **Designated States (unless otherwise indicated, for every kind of regional protection available):** ARIPO (BW, GH, GM, KE, LR, LS, MW, MZ, NA, SD, SL, SZ, TZ, UG, ZM, ZW), Eurasian (AM, AZ, BY, KG, KZ, MD, RU, TJ, TM), European (AL, AT, BE, BG, CH, CY, CZ, DE, DK, EE, ES, FI, FR, GB, GR, HR, HU, IE, IS, IT, LT, LU, LV, MC, MK, MT, NL, NO, PL, PT, RO, SE, SI, SK, SM, TR), OAPI (BF, BJ, CF, CG, CI, CM, GA, GN, GQ, GW, ML, MR, NE, SN, TD, TG).

**Declarations under Rule 4.17:**

— of inventorship (Rule 4.1 7(iv))

[Continued on next page]

(54) **Title:** BATTERY POWERED TOOL

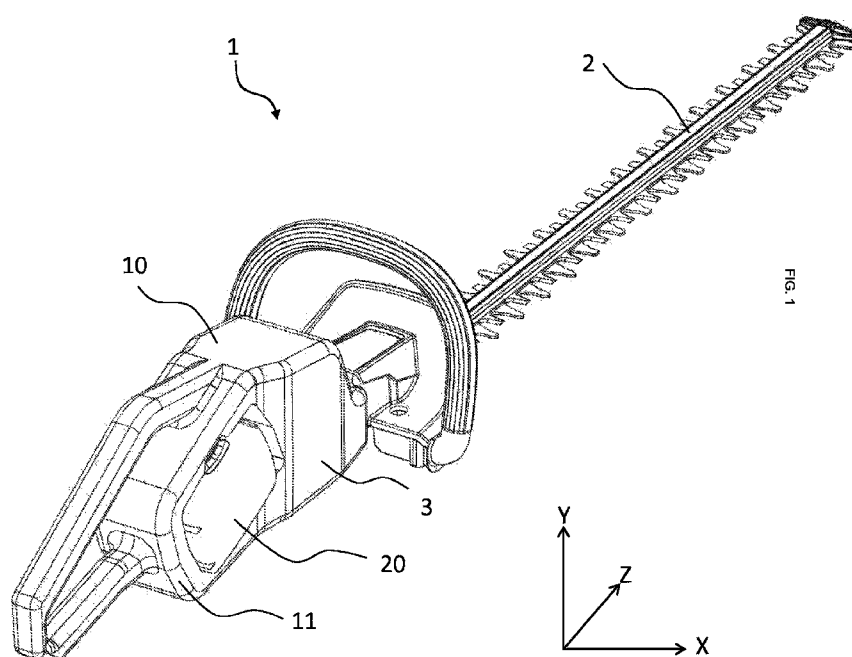

(57) **Abstract:** The present disclosure relates to a battery powered tool (1) extending in a longitudinal direction (Z), comprising a tool body (10) and a battery pack (20), which battery pack is arranged on the tool body and adapted to power the tool. The tool body is provided with a through aperture adapted to receive the battery pack, such that the tool body at least partly surrounds the battery pack.



WO 2012/002860 A1

Published:

— with international search report (Art. 21(3))

## BATTERY POWERED TOOL

### Technical field

5           The present disclosure relates to a power tool and more particularly to a battery powered tool .

### Background

10           The battery pack constitutes a considerable part of the weight of a battery powered tool. In large tools it is important that the battery pack is placed in a good place on the tool to provide good ergonomics for a user. Further, a battery powered tool such as, but not limited to, a chain saw, a hedge trimmer or a vegetation trimmer, may be used in rough environments, providing extra demands for a robust design of the tool. In common designs  
15           of a handheld power tool, the battery pack is attached to the tool body by hanging fully exposed underneath the tool body. It is thereby exposed to impacts that may occur during use in a rough environment. Such impacts could cause damage to the battery pack or cause that the battery pack loses from its connection to the tool. Further, a solution to that problem could be to  
20           mount the battery inside the tool body. However, such solution provides an inaccessible battery pack that needs much effort from a user to be removed from the tool.

          Further, for a handheld power tool such as a trimmer or a chain saw, it is important that the center of gravity of the tool is located such that good  
25           ergonomics for the user is provided. At some occasions it may be useful if the handheld power tool is able to receive battery packs of different sizes. In present solutions, a change to a larger battery pack may cause an overweight to either side of the power tool, such that an unbalance in the power tool occurs. Such unbalance affects the ergonomics of the power tool for the user  
30           negatively.

Consequently, there is a need for a tool with a battery pack that is easy accessible and still not exposed to impacts, and further a tool that provides good ergonomics for the user even for different battery pack sizes.

5            Summary

In view of the above, it is an objective to solve or at least reduce the problems discussed above. In particular, an objective is to provide a battery powered tool that protects the battery pack and that provides good ergonomics for a user.

10           This is achieved by providing a battery powered tool extending in a longitudinal direction, comprising a tool body and a battery pack which battery pack is arranged on the tool body and adapted to power the tool. The battery powered tool is characterized in that the tool body is provided with a through aperture adapted to receive the battery pack, such that the tool body at least  
15 partly surrounds the battery pack.

A battery powered tool is thereby provided wherein the tool body may have a protective structure surrounding the battery pack. It may then be avoided that the battery pack is hit during use such that it would be damaged or would come loose from the connection with the tool body. The protective  
20 structure may be a stiff structure that surrounds the battery pack. A tool body that surrounds the battery pack may also be provided with a lifting means, such as a hook or similar, at the longitudinal end portion of the tool body, which means would not be possible to provide on a battery pack being mounted unprotected at the end portion of the tool body.

25           In one embodiment, the through aperture may elongate in a direction perpendicular to the longitudinal direction of the tool. A battery pack that is mounted in a through aperture elongating in the same longitudinal direction as the tool, may be exposed to a larger risk of impact with trees or other obstacles during use of the tool in a rough environment. With the through  
30 aperture in a direction perpendicular to the longitudinal extension direction of the tool, the ergonomics for the user may be preserved good even for different sizes of the battery pack.

In another embodiment, a length of the battery pack is substantially the same as a length of the through aperture. The battery pack may thereby be visible from the outside of the tool body, but surrounded by the tool body such to be protected from impacts. The battery pack may not protrude outside the tool body, and thereby not being exposed to impacts.

In a further embodiment, the at least one end of the battery pack may protrude outside the tool body when mounted in the through aperture. Thereby, the possibility of variable sizes of battery packs for the tool may be provided.

In a yet further embodiment, two ends of the battery pack may protrude outside the tool in two directions along the elongation direction of the through aperture when the battery is mounted in the through aperture.

In another embodiment, the battery pack may be adapted to protrude in substantially equal amounts in the two directions. By having the battery pack protrude in equal amounts in the two directions outside the tool body, the balance in the tool may be kept at a good level even for different sizes of battery pack. A larger battery pack may thereby not cause an overweight in any of the two directions, instead it is kept centrally located on the tool. Such overweight may otherwise cause an unwanted rotational movement around the longitudinal extension direction of the tool.

According to one embodiment, the tool body may be provided with a connector within the through aperture, which connector may be adapted to integrate with a corresponding connector on the battery pack when the battery pack is mounted in the through aperture. The connectors may be adapted to transfer power from the battery pack to the tool body. The tool body may comprise an electric motor adapted to be powered by the battery pack. Further, the connectors may provide a holding or locking function for the battery pack in the through aperture. The connectors may thereby be designed in order to lock the battery pack such that it may not fall out from the through aperture by itself. The battery pack may be unlocked by a user.

In a further embodiment, the battery pack may be visible from the outside when mounted in the through aperture. Thereby, the battery pack may be surrounded by the tool body, but not in a way that provides that the

battery pack is not visual from the outside. Since the battery pack is mounted in a through aperture, it may be visual from two sides of the tool body. By being visual from the outside, the battery pack may be easy accessible even though it may be surrounded by the tool body. A removal of the battery pack  
5 may not need excessive effort from a user. The battery pack may further be provided with an indicator, which indicator may provide information about the power status of the battery pack. The indicator may be visual from the outside directly on the battery pack.

In a further embodiment, the battery powered tool may be provided  
10 with an indicator that may indicate whether or not the battery pack is correctly fitted in the through aperture. Such indicator may be visual from the outside such that an operator may see the indication whether the battery pack is correctly positioned in the through aperture. Thereby, it may be avoided that the battery pack is incorrectly fitted in the through aperture, which may  
15 damage the battery pack or the tool body. The indicator may in one embodiment be a color marking, indicating the correct or incorrect position of the battery pack.

In one embodiment, the battery pack may comprise a locking device adapted to lock the battery pack to the tool. Thereby, it may be avoided that  
20 the battery pack may unintentionally loose from the mounting position in the through aperture.

In another embodiment, the tool may be a handheld garden tool or a handheld forestry tool. Such handheld garden tool or forestry tool may be, but not limited to, a hedge trimmer, trimmer, chain saw, top handle chain saw or  
25 the like.

#### Brief description of the drawings

The invention will in the following be described in more detail with reference to the enclosed drawings, wherein:

30 Fig. 1 shows a perspective view of a battery powered tool according to an embodiment of the invention.

Fig. 2 shows a perspective view of a rear part of a battery powered tool with a mounted battery pack according to an embodiment of the invention.

Fig. 3 shows a perspective view of a rear part of a battery powered tool with a mounted battery pack according to an embodiment of the invention.

Fig. 4 shows a perspective view of a rear part of a battery powered tool according to an embodiment of the invention.

5 Fig. 5 shows a perspective view of a battery pack according to an embodiment of the invention.

#### Detailed description of embodiments

The present invention will be described more fully hereinafter with  
10 reference to the accompanying drawings, in which preferred embodiments of the invention are shown. This invention may, however, be embodied in many different forms and should not be construed as limited to the embodiments set forth herein; rather, these embodiments are provided so that this disclosure will be thorough and complete, and will fully convey the scope of the invention  
15 to those skilled in the art. In the drawings, like numbers refer to like elements.

Fig. 1 describes a battery powered tool 1, in this case a battery powered hedge trimmer, with a longitudinal extension along direction Z, wherein an operating part 2 is located in one end of the tool 1. The tool 1 further comprises a tool body 10. In an end of the tool opposite of the end  
20 holding the operating part 2, the tool body 10 comprises a through aperture for receiving a battery pack 20. The battery pack is adapted to power an electric motor 3 in the tool 1. The electric motor drives the operating part 2 during operation of the tool 1. The through aperture elongates through the tool body 10 in a direction X, Y that is perpendicular to the longitudinal  
25 extension direction Z of the tool 1. This elongation direction of the through aperture is preferably through the sides of the tool body 10 in the direction X. The through aperture may also be through the top and the bottom of the tool body along the direction Y. The battery pack 20 extends through the through aperture and is locked in the through aperture by a locking means 23. When  
30 the battery pack 20 is mounted in the through aperture, the battery pack 20 is surrounded by a surrounding part 11 of the tool body 10. The surrounding part 11 is stiff and protects the battery pack 20 when it is mounted in the through aperture. Since the surrounding part 11 surrounds the battery pack

20 in the outermost part of the tool body 10 along the longitudinal direction Z, the tool body 10 may in that outermost surrounding part 11 be provided with a hook or similar fastening means. Such hook may be used for fastening a rope that could be used as a safety feature. Such safety feature may be useful  
5 when using the tool in a tree.

Fig. 2 describes a battery pack 20 of normal size mounted in the through aperture 12 in the tool body 10. The battery pack 20 is visible from the outside, but no part of the battery pack 20 extends outside the tool body 10. The length of the battery pack 20 along the direction X is similar as the  
10 extension length of the through aperture 12 in the tool body 10 along the direction X. The battery pack 20 is thereby completely protected by the tool body 10 and the surrounding part 11, and no parts of the battery pack 20 protrudes outside the tool body 10. The battery pack 20 may also have a length that is shorter than the extension length of the through aperture.

Fig. 3 describes a battery pack 20 of a larger size, with larger power capacity than a normal sized battery pack, mounted in the through aperture 12 in the tool body 10. Two extending parts 21 of the battery pack 20 extends outside the tool body 10 on each side of the through aperture 12 along the direction X. Preferably the two extending parts 21 have substantially equal  
20 length such that the battery pack 20 extends outside the tool body 20 with a substantially equal amount on each side of the tool body 10. Thereby, the weight distribution around the axis Z will still be in balance even when a larger battery pack 20 is mounted in the through aperture 12. If needed for any reason, a battery pack extending outside the through aperture 12 could  
25 extend further on one side of the tool body then on the other side. The same battery pack 20 could be used for several different power tools having different power consumption. The different power tools may thereby all be designed and arranged for receiving the same battery packs of different sizes such that the balance is kept for all the different power tools with different  
30 battery packs.

Fig. 4 describes the tool body 10 with an empty through aperture 12. The through aperture 12 comprises a female connector 13. The female



connector 13 is used for power transfer from the battery pack 20, via the connector 13, to the electric motor 3.

Fig. 5 describes a battery pack 20 with a corresponding male connector 22 adapted to integrate with the female connector 13 in the through aperture 12 for power transfer to the motor 3 in the tool 1. The female connector 13 in the through aperture 12 is provided with a number of tongues adapted to integrate with an equal number of apertures in the battery pack male connector 22. The tongues are of metal adapted to conduct electricity from the battery pack 20 to the tool. The female and male connectors 13, 22 may be placed on the contrary, such that the male connector with tongues is placed on the battery pack 20, and the female connector is placed in the through aperture 12.

Due to the connectors 13, 22, the battery pack 20 needs to be inserted in the through aperture 12 from a certain direction. The position of the connectors 13, 22 also decides how the battery pack 20 extends when mounted in the through aperture 12. The connector 13 in the through aperture 12 is preferably placed in the middle, or close to the middle, of the length along the direction X of the through aperture 12. Correspondingly, the connector 22 on the battery pack 20 is preferably placed in the middle, or close to the middle, of the length along the direction X of the battery pack 20. Thereby, the battery pack 20 will extend outside the tool body 10 in equal amounts in the two directions along the direction X.

The battery pack 20 further comprises a locking device 23. The locking device 23 is adapted to lock the battery pack 20 to the tool body 10 when the battery pack 20 is mounted in the through aperture 12. The locking device 23 needs to securely hold the battery pack 20 in the through aperture 12 during use of the tool 1. Further, the locking device 23 needs to be easy to unlock in order to enable easy unmounting of the battery pack 20 from the tool body 10.

CLAIMS

1. A battery powered tool (1) extending in a longitudinal direction (Z), comprising a tool body (10) and a battery pack (20), which battery pack is  
5 arranged on the tool body and adapted to power the tool,

**characterized in that** the tool body (10) is provided with a through aperture (12) adapted to receive the battery pack (20), such that the tool body at least partly surrounds the battery pack.

10 2. Battery powered tool according to claim 1, wherein the through aperture (12) elongates in a direction (X) perpendicular to the longitudinal extension direction (Z) of the tool.

15 3. Battery powered tool according to claim 1 or 2, wherein a length of the battery pack (20) is substantially the same as a length of the through aperture (12).

20 4. Battery powered tool according to claim 1 or 2, wherein at least one end (21) of the battery pack (20) protrudes outside the tool body (10) when mounted in the through aperture (12).

25 5. Battery powered tool according to claim 1 or 2, wherein two ends (21) of the battery pack protrude outside the tool body (10) in two directions along the elongation direction (X) of the through aperture (12) when the battery pack (20) is mounted in the through aperture.

30 6. Battery powered tool according to claim 5, wherein the two ends (21) of the battery pack (20) is adapted to protrude in substantially equal amounts in the two directions.

7. Battery powered tool according to any of the preceding claims, wherein the tool body (10) is provided with a connector (13) within the through aperture (12), which connector is adapted to integrate with a corresponding

connector (22) on the battery pack (20) when the battery pack is mounted in the through aperture (12).

8. Battery powered tool according to any of the preceding claims,  
5 wherein the battery pack (20) is visible from the outside when mounted in the through aperture (12).

9. Battery powered tool according to any of the preceding claims,  
wherein the battery powered tool (1) is provided with an indicator adapted to  
10 indicate whether or not the battery pack (20) is correctly fitted in the through aperture (12).

10. Battery powered tool according to any of the preceding claims,  
wherein the battery pack (20) comprises a locking device (23) adapted to lock  
15 the battery pack to the tool body (10).

11. Battery powered tool according to any of the preceding claims,  
wherein the tool (1) is a handheld garden tool.

20 12. Battery powered tool according to any of the claims 1-10, wherein the tool (1) is a handheld forestry tool.

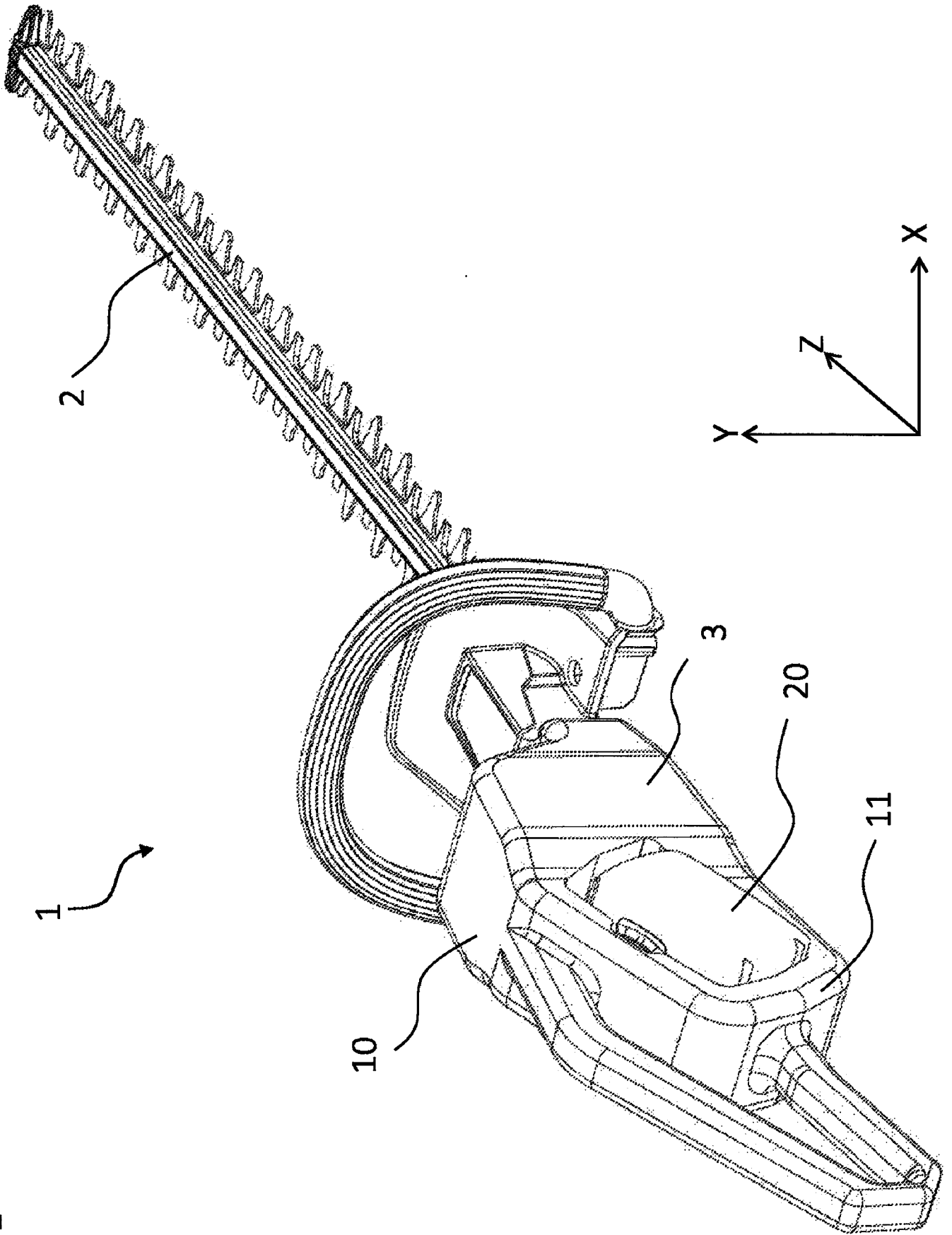
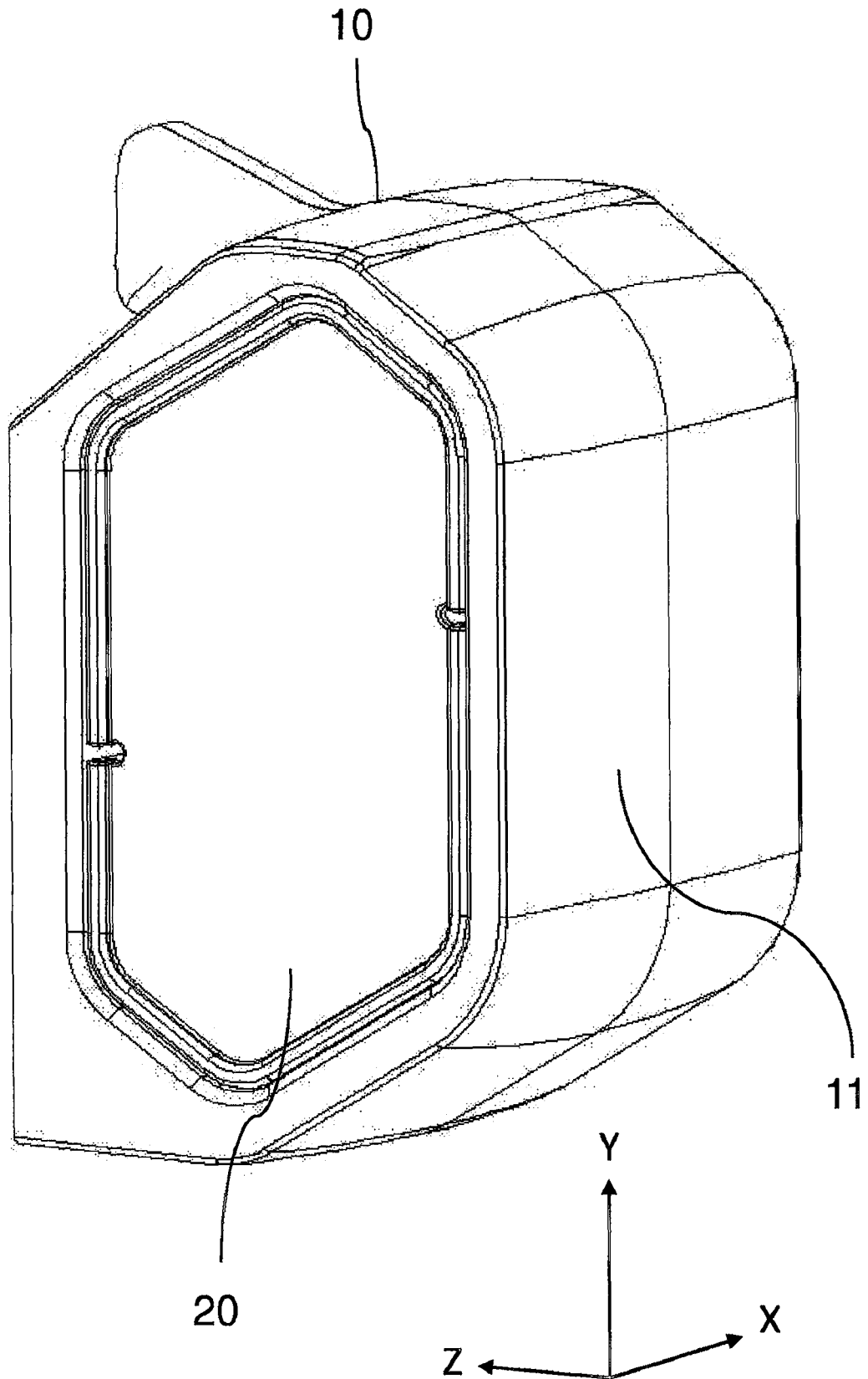
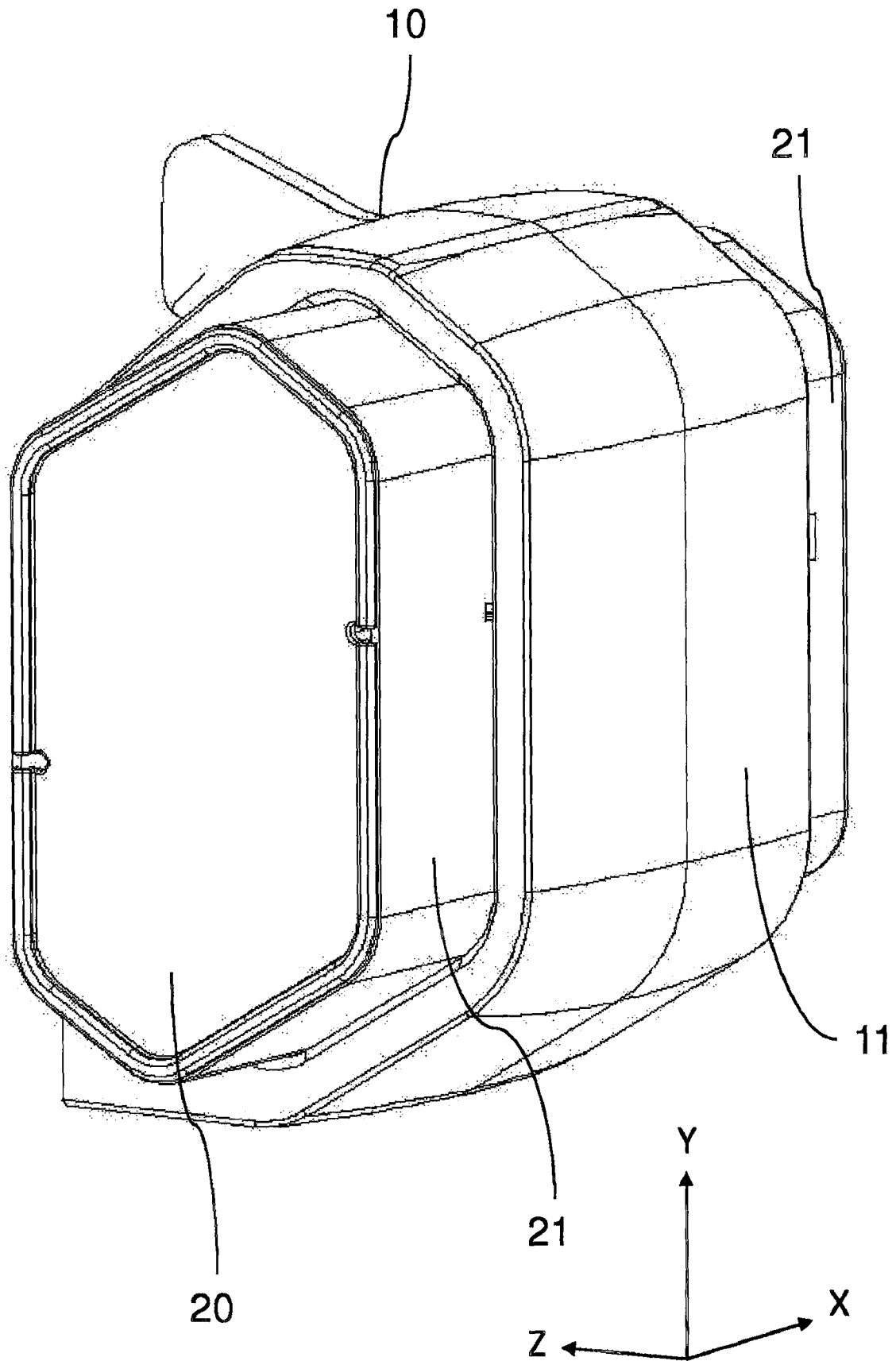

Fig. 1

**Fig. 2**



**Fig. 3**



**Fig. 4**

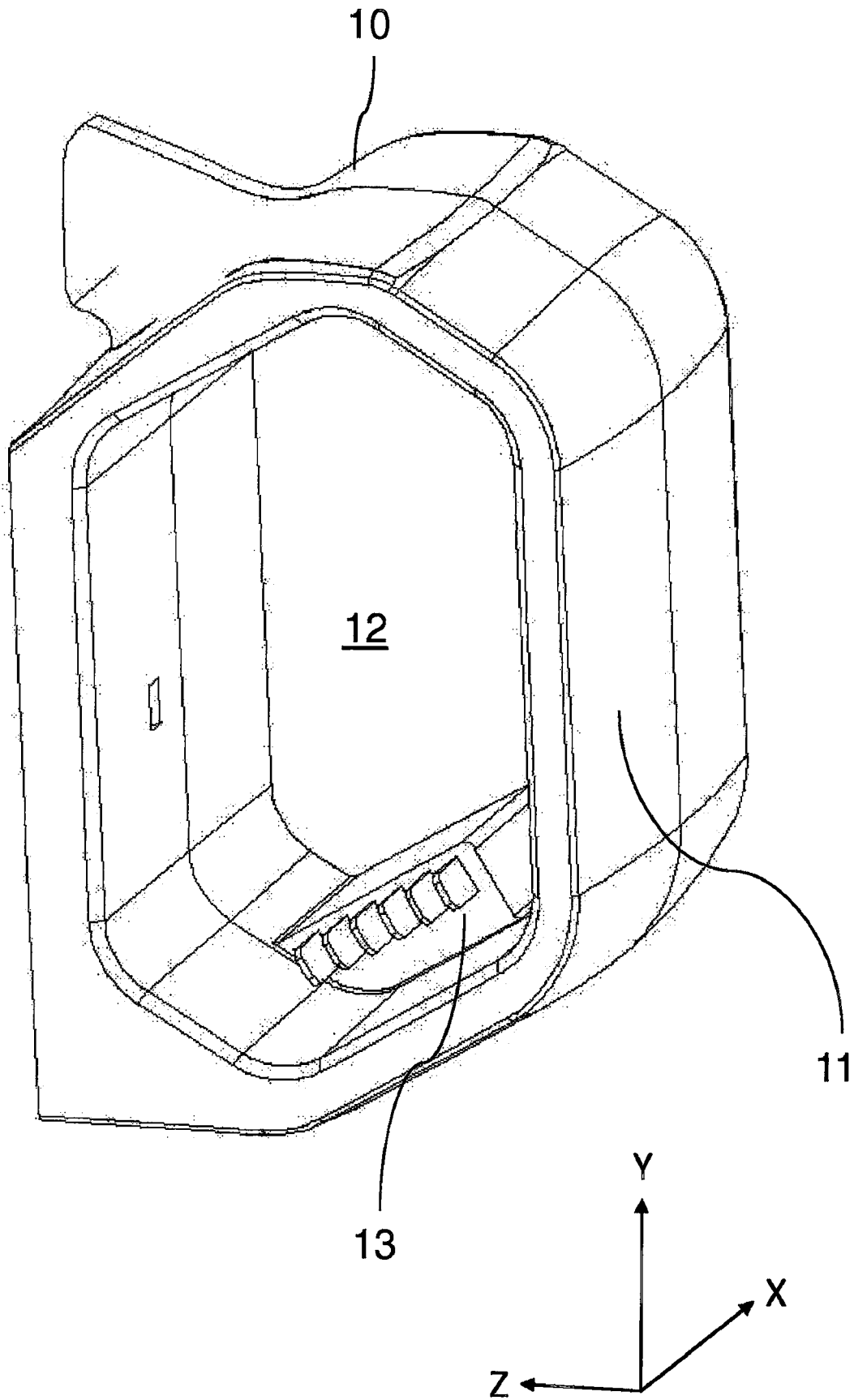

**Fig. 5**

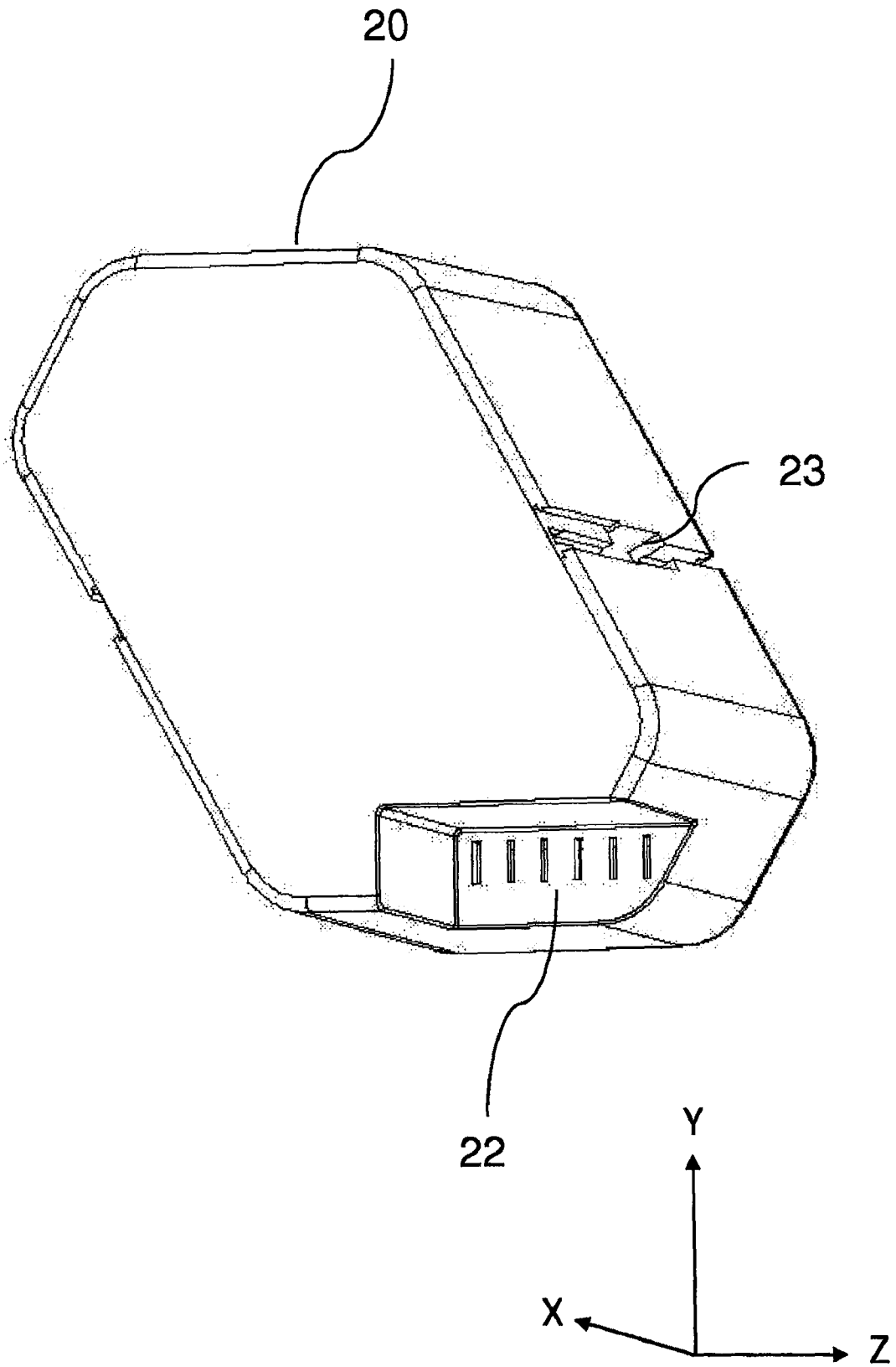



**INTERNATIONAL SEARCH REPORT**

<b>International application No.</b> PCT/SE2010/050765
---

**A. CLASSIFICATION OF SUBJECT MATTER**

IPC: see extra sheet  
According to International Patent Classification (IPC) or to both national classification and IPC

**B. FIELDS SEARCHED**

Minimum documentation searched (classification system followed by classification symbols)

IPC: B25F, A01G, B23D

Documentation searched other than minimum documentation to the extent that such documents are included in the fields searched

SE,DK,FI,NO classes as above

Electronic data base consulted during the international search (name of data base and, where practicable, search terms used)

EPO-INTERNAL, WPI DATA, PAJ

**C. DOCUMENTS CONSIDERED TO BE RELEVANT**

Category*	Citation of document, with indication, where appropriate, of the relevant passages	Relevant to claim No.
A	EP 1075906 A3 (BLACK & DECKER INC.), 14 February 2001 (14.02.2001), whole document'  --	1-12
A	US 20080196256 A1 (GIESKE ET AL), 21 August 2008 (21.08.2008), whole document  --	1-12
A	EP 1205282 A2 (ILLINOIS TOOL WORKS INC.), 15 May 2002 (15.05.2002), whole document  --	1-12
A	WO 2008156602 A1 (BLACK & DECKER INC.), 24 December 2008 (24.12.2008), whole document  -- -----	1-12

Further documents are listed in the continuation of Box C.  See patent family annex.

* Special categories of cited documents:	"T" later document published after the international filing date or priority date and not in conflict with the application but cited to understand the principle or theory underlying the invention
"A" document defining the general state of the art which is not considered to be of particular relevance	"X" document of particular relevance: the claimed invention cannot be considered novel or cannot be considered to involve an inventive step when the document is taken alone
"E" earlier application or patent but published on or after the international filing date	"Y" document of particular relevance: the claimed invention cannot be considered to involve an inventive step when the document is combined with one or more other such documents, such combination being obvious to a person skilled in the art
"L" document which may throw doubts on priority claim(i) or which is cited to establish the publication date of another citation or other special reason (as specified)	"&" document member of the same patent family
"O" document referring to an oral disclosure, use, exhibition or other means	
"P" document published prior to the international filing date but later than the priority date claimed	

<b>Date of the actual completion of the international search</b> 8 March 2011	<b>Date of mailing of the international search report</b> 17 -03- 2011
--	---

<b>Name and mailing address of the ISA/ Swedish Patent Office Box 5055, S-102 42 STOCKHOLM Facsimile No. + 46 8 666 02 86</b>	<b>Authorized officer</b>  Anders Toll / JA A <b>Telephone No. +46 8 782 25 00</b>
---	---

INTERNATIONAL SEARCH REPORT

International application No.  
PCT/SE2010/050765

International patent classification (IPC)

**B25F 5/02** (2006.01)  
**A01G 3/053** (2006.01)  
**A01G 3/06** (2006.01)  
**B23D 49/12** (2006.01)

**Download your patent documents at [www.prv.se](http://www.prv.se)**

The cited patent documents can be downloaded:

- From "Cited documents" found under our online services at [www.prv.se](http://www.prv.se) (English version)
- From "Anforda dokument" found under "e-tjanster" at [www.prv.se](http://www.prv.se) (Swedish version)

Use the application number as username. The password is **VTKVIKRIBG**.

Paper copies can be ordered at a cost of 50 SEK per copy from PRV InterPat (telephone number 08-782 28 85) .

Cited literature, if any, will be enclosed in paper form.

## INTERNATIONAL SEARCH REPORT

International application No.

PCT/SE2010/050765

EP	1075906	A3	14/02/2001	SE	1075906	T3	
				AT	243606	T	15/07/2003
				AU	4722200	A	18/01/2001
				CN	1191917	C	09/03/2005
				CN	1281775	A	31/01/2001
				DE	60003499	D,T	19/05/2004
				US	6181032	B	30/01/2001

---

US	20080196256	AI	21/08/2008	NONE			
----	-------------	----	------------	------	--	--	--

---

EP	1205282	A2	15/05/2002	AT	383228	T	15/01/2008
				AU	755116	B	05/12/2002
				AU	8361001	A	16/05/2002
				CA	2359791	A	14/05/2002
				DE	60132284	D,T	24/12/2008
				DK	1205282	T	19/05/2008
				ES	2299469	T	01/06/2008
				JP	2002219672	A	06/08/2002
				JP	2008235282	A	02/10/2008
				MX	PA01011584	A	07/06/2002
				NO	20015550	A	15/05/2002
				NZ	515080	A	30/06/2003

---

Wo	2008156602	AI	24/12/2008	NONE			
----	------------	----	------------	------	--	--	--

---