



US007426224B2

(12) **United States Patent**
Ishibashi

(10) **Patent No.:** **US 7,426,224 B2**
(45) **Date of Patent:** **Sep. 16, 2008**

(54) **OPTICAL TRANSMITTER WITH A DIGITALLY CONTROLLED BIAS AND MODULATION CURRENTS FOR A LASER DIODE**

(58) **Field of Classification Search** 372/29.01, 372/29.011, 29.014, 29.015, 38.1, 38.01, 372/38.02, 38.07

See application file for complete search history.

(56) **References Cited**

U.S. PATENT DOCUMENTS

6,885,685 B2 * 4/2005 Hidaka et al. 372/38.02
7,106,768 B2 9/2006 Murata

FOREIGN PATENT DOCUMENTS

JP 2000-022631 1/2000

* cited by examiner

(75) Inventor: **Hiroto Ishibashi**, Yokohama (JP)

(73) Assignee: **Sumitomo Electronic Industries, Ltd.**,
Osaka (JP)

(*) Notice: Subject to any disclaimer, the term of this patent is extended or adjusted under 35 U.S.C. 154(b) by 0 days.

Primary Examiner—Armando Rodriguez

(74) *Attorney, Agent, or Firm*—Smith, Gambrell & Russell, LLP

(57) **ABSTRACT**

The present invention is to provide an optical transmitter that installs a laser diode and a circuit to control currents supplied to the laser diode, and reduces the size of the control circuit. The transmitter includes an LD, an LD-Driver, a monitor PD, and a control unit that outputs two data for the bias and modulation currents to the driver based on the photocurrent. The control unit provides a memory whose addresses correspond to the bias current, while a data for the modulation current is set within an address of the memory. Accordingly, the control unit adjusts the bias current so as to maintain the photocurrent constant and outputs the data for the modulation current to the driver by reading information stored in the address corresponding to the bias current.

(21) Appl. No.: **11/790,073**

(22) Filed: **Apr. 23, 2007**

(65) **Prior Publication Data**

US 2007/0248130 A1 Oct. 25, 2007

(30) **Foreign Application Priority Data**

Apr. 25, 2006 (JP) 2006-120862

(51) **Int. Cl.**

H01S 3/13 (2006.01)

H01S 3/00 (2006.01)

(52) **U.S. Cl.** 372/29.01; 372/38.02

3 Claims, 4 Drawing Sheets

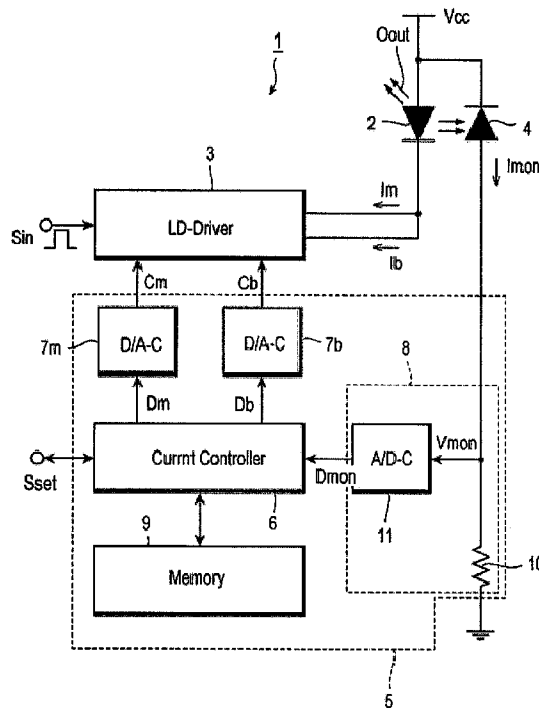

FIG. 1

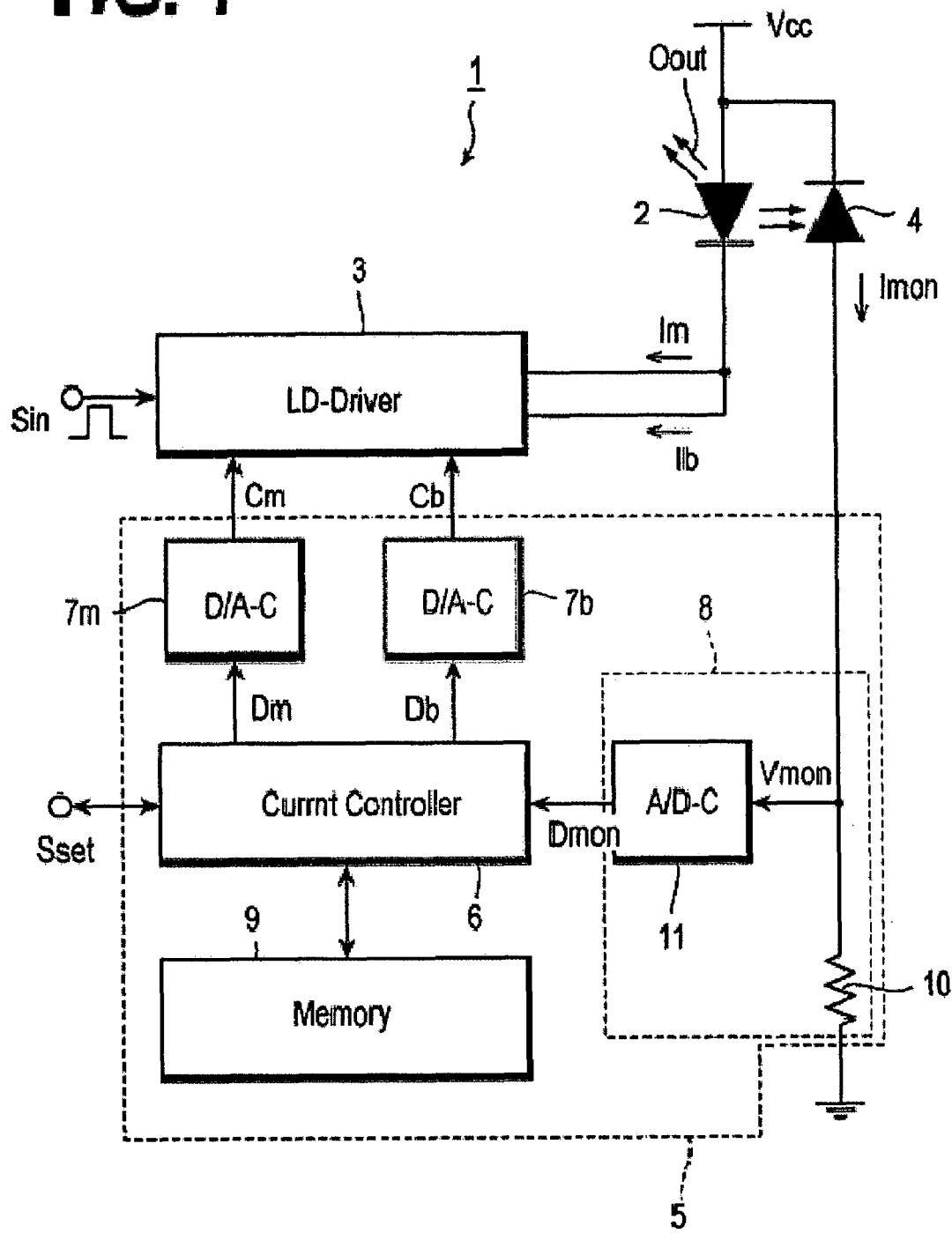

Fig. 2

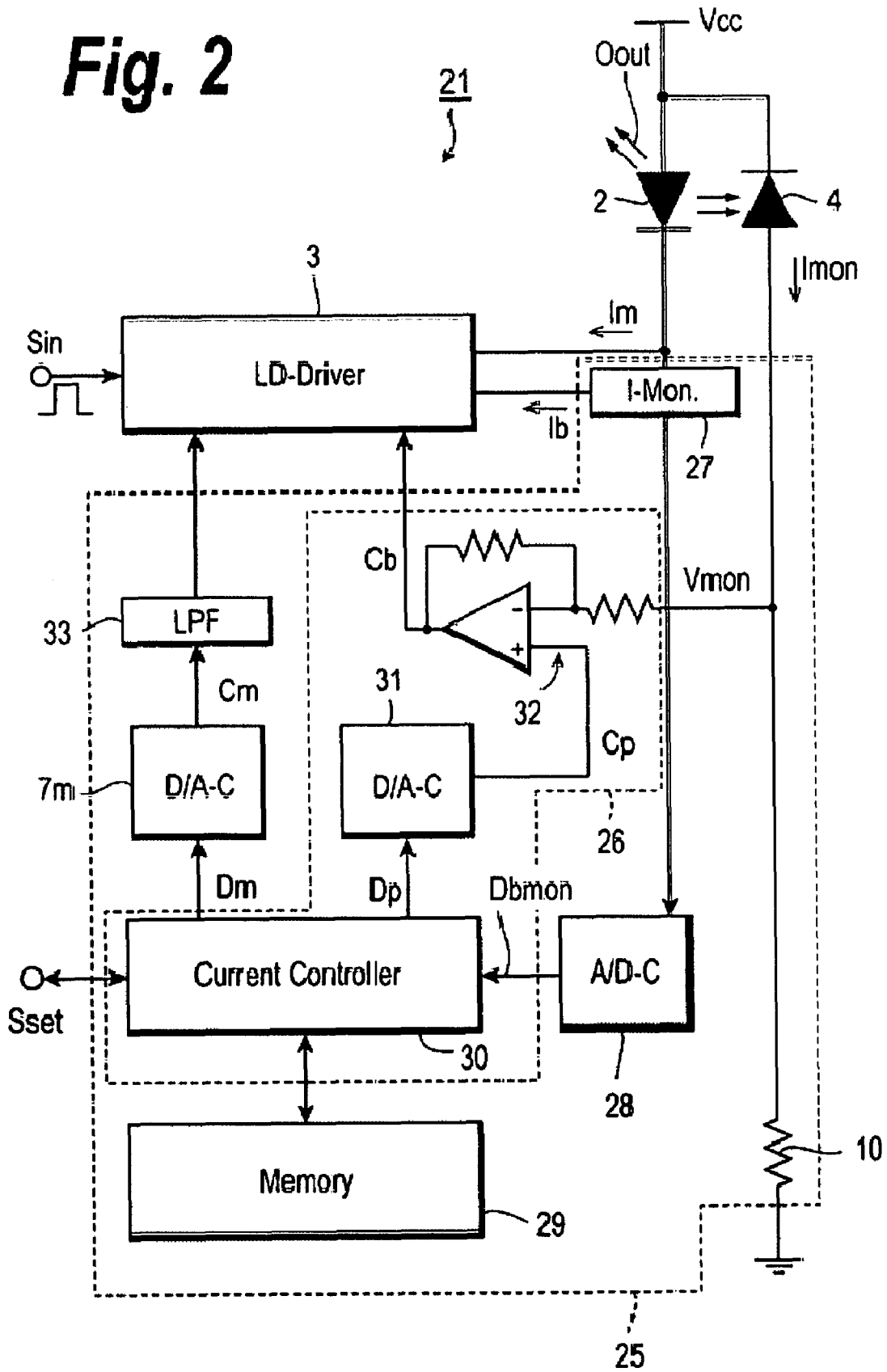

FIG. 3

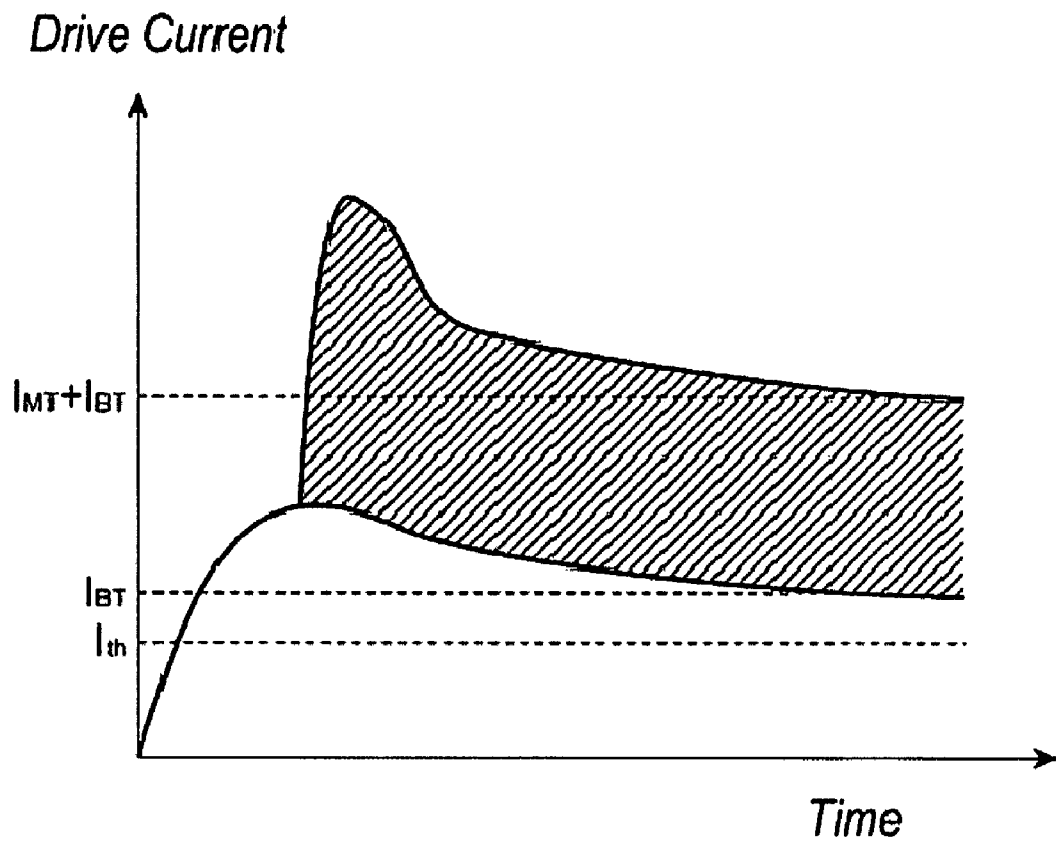
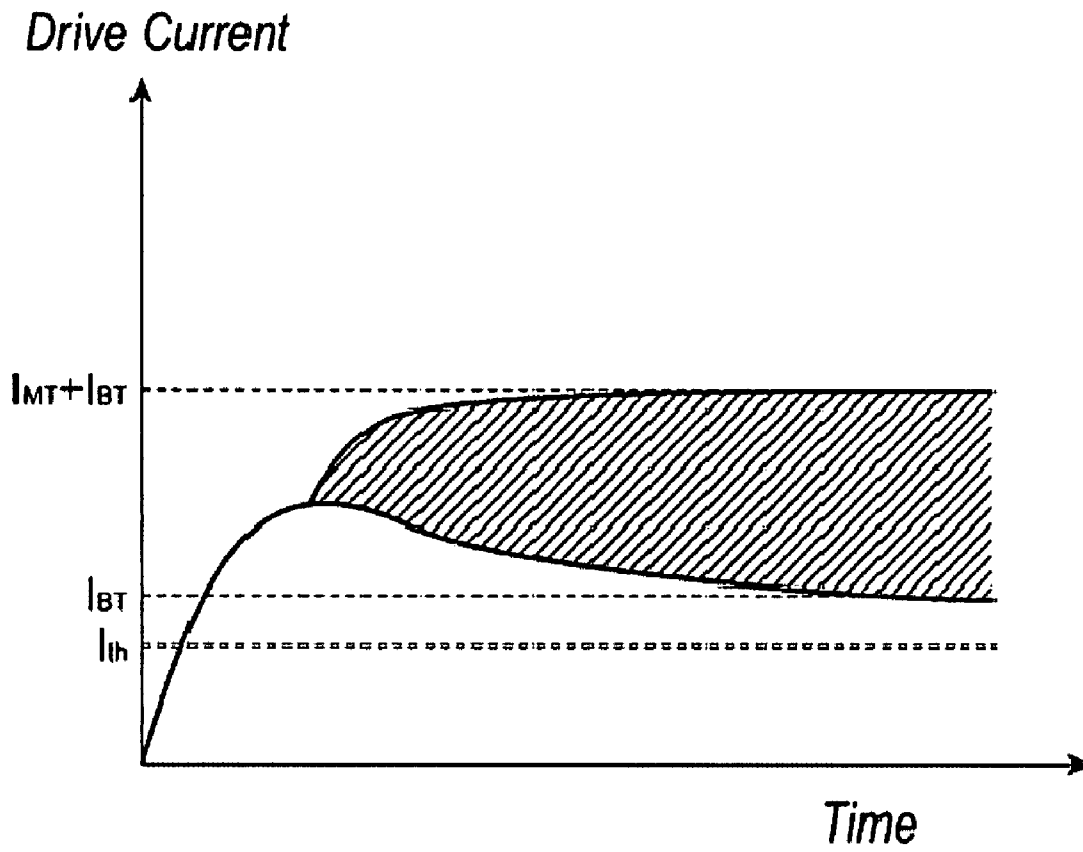

FIG. 4



1

OPTICAL TRANSMITTER WITH A DIGITALLY CONTROLLED BIAS AND MODULATION CURRENTS FOR A LASER DIODE

BACKGROUND OF THE INVENTION

1. Field of the Invention

The present invention relates to an optical transmitter, in particular, the invention relates to an optical transmitter that installed within an optical data link for the optical communication and installs a semiconductor laser diode digitally controlled in the bias and modulation current supplied thereto.

2. Related Prior Art

Various techniques and circuits have been disclosed to control the optical output from the laser diode in the magnitude and the extinction ratio thereof. The United States Patent, U.S. Pat. No. 7,106,768, has disclosed a method to control the LD, where the controller reads from the memory a pair of data, one for the bias current and the other for the modulation current, and sets both currents based on thus read data.

The memory of the transmitter disclosed in the prior art above stores a set of combinations of the currents to obtain a desired optical power and an extinction ratio for the LD. Such combinations of the currents strongly depends on individual devices, accordingly, it is necessary to measure optimal combinations of the currents to maintain the desired optical power and the extinction ratio as varying a temperature of the LD and to store such combinations in the memory at the initial operation of the transmitter. Thus, a large size of the memory is necessary to enhance the preciseness of the control of the LD, which enlarges the circuit size and raises the cost of the transmitter.

The present invention, considering the subjects mentioned above, is to provide an optical transmitter where the size of the data stored in the memory may be saved and accordingly the physical size thereof may be reduced.

SUMMARY OF THE INVENTION

An aspect of the present invention relates to a configuration of the optical transmitter. The optical transmitter according to the invention includes a semiconductor laser diode (LD), a driver, a photodiode (PD), and a control unit. The LD outputs an optical signal with a predetermined magnitude and a predetermined extinction ration by receiving modulation and bias currents. The driver sets the modulation and bias currents to the LD by receiving one set of data each corresponding to bias and modulation currents, respectively. The PD monitors a portion of the optical signal output from the LD and generates a photocurrent. The control unit includes a current controller and a memory. The memory stores a plurality of data each corresponding to the modulation current in addresses in connection with the bias current. The current controller sets a first data for the bias current based on the photocurrent, sets a second data for the modulation current read from an address of the memory in connection with the first data and outputs the one set of data, which includes above first and second data, to the driver.

The memory of the present optical transmitter stores a set of second data for the modulation current. The current controller reads out one of second data from an address that relates to the bias current determined so as to maintain the photocurrent constant, where the combination of the first and second data has the optical output of the LD to show the predetermined magnitude and the predetermined extinction

2

ratio. Thus, the memory only stores one of set of data for the bias current or for the modulation current, which makes the size of the circuit compact in physical and electrical.

Another aspect of the present invention relates to a method for controlling an optical transmitter that provides an LD, a PD, a driver and a control unit. The method comprises steps of: (a) monitoring the photocurrent by the control unit; (b) setting a first data for the bias current so as to maintain the monitored signal output from the PD constant; (c) setting a second data for the modulation current from an address in connection with the first data for the bias current; (d) providing a set of data including first and second data to the driver from the control unit, and (e) providing the bias current and the modulation current each determined by the first and second data, respectively, to the LD.

BRIEF DESCRIPTION OF DRAWINGS

FIG. 1 is a block diagram showing an optical transmitter according to a first embodiment of the present invention;

FIG. 2 is another block diagram of an optical transmitter according to a second embodiment of the inventions;

FIG. 3 shows a response of the driving current for the LD without a low-pass-filter between the driver and the control unit; and

FIG. 4 shows a response of the driving current when the transmitter provides the filter between the driver and the control unit.

DESCRIPTION OF PREFERRED EMBODIMENTS

Next, preferred embodiments according to the present invention will be described as referring to accompanying drawings. In the description, the same numerals or the symbols will refer to the same elements without overlapping explanations.

First Embodiment

FIG. 1 is a block diagram of an optical transmitter 1 according to an embodiment of the present invention. The optical transmitter 1 is applicable to an optical data link and includes a laser diode (LD) 2 to output an optical signal Oout, an LD-Driver 3 to supply currents to the LD 2, a photodiode (PD) 4 to monitor a portion of the optical signal Oout, and a control unit 5 to adjust the current supplied to the LD-Driver 3.

The LD 2 is, in the anode electrode thereof, connected with a power supply Vcc, while, in the cathode thereof, connected with output terminals of the LD-Driver 3. The LD-Driver 3, depending on control signals, Cm and Cb, provides the modulation current Im and the bias current Ib to the LD 2. The LD-Driver 3 modulates the modulation current Im by the input signal Sin, which is input thereto.

The cathode of the PD 4 is also connected to the power supply Vcc. The PD, by receiving a portion of the optical output Oout, generates a photocurrent Imon.

The control unit 5 includes a current controller 6, two digital-to-analog converters (D/A-C), 7a and 7b, a monitor unit 8 to monitor the photocurrent Imon, and a memory 9 coupled with the current controller 6.

The monitor unit 8 includes a resistor 10 and an analog-to-digital converter (A/D-C) 11. The resistor 10, connected to the anode of the PD 4, converts the photocurrent Imon into a corresponding voltage signal Vmon. The A/D-C 11, also con-

3

nected to the anode of the PD 4, converts the voltage signal V_{mon} to a digital signal D_{mon}.

The current controller 6, constituted with, for example, a central processing unit (CPU) and other digital circuits, sets the control signals, D_m and D_b, based on the input digital signal D_{mon} to respective D/A-Cs, 7_m and 7_b.

Specifically, the current controller 6 is configured to compare the input digital signal D_{mon} with a preset signal S_{set}, to vary the signal D_b by a predetermined step ΔS_b so as to minimize a difference of the signal D_{mon} from the preset signal, and to set the signal D_m by accessing an address of the memory 9 that corresponds to the digital signal D_b and reading information stored therein.

Table I below shows an architecture of the memory 9 to determine the modulation current D_m. The address “index+0” of the memory 9, which corresponds to the minimum value of the bias current, D_{bmin}, stores a data D_{m0} for the modulation current that reflects the value D_{bmin}. The address “index+1”, which corresponds to the bias current D_{bmin}+ΔS_b, stores a data D_{m1}, which is connected to the bias current D_{bmin}+ΔS_b. Thus, a plurality of bias currents from the minimum, D_{bmin}, to the maximum, D_{bmax}, with the interval ΔS_b are reflected in the addresses of the memory 9, and an address “index+(I-1)”, which corresponds to a bias current D_{bmin}+(I-1)×ΔS_b, stores a data D_{m(I)} for the modulation current. The current controller 6, by accessing the memory 9, sets one combination of the bias current, D_{bmin}+(I-1)×ΔS_b and the paired modulation current D_{m(I)}.

TABLE I

Memory Configuration	
Address	Data
Index + 0	D _{m0}
Index + 1	D _{m1}
...	...
Index + n	D _{mn}

Referring to FIG. 1 again, two D/A-Cs, 7_m and 7_b, convert the control signals, D_m and D_b, output from the current controller 6 into respective analog signals, C_m and C_b, and provides then to the LD-Driver 3.

Next, a method to set the table I in the memory 9 will be described.

First, a combination of data {D_m, D_b} (i) is selected such that the optical output O_{out} shows preset magnitude and extinction ratio by monitoring the photocurrent I_{mon} at an initializing routine for the transmitter 1 where the current controller 6 is in standstill and an ambient temperature is kept constant. Subsequently, a plurality of combinations {D_m, D_b} (i=1, . . . , m) is determined as varying the ambient temperature. For each combination {D_m, D_b} (k) at a temperature T_k, the optical output O_{out} shows the preset magnitude and the present extinction ratio. An optimal combination of data {D_m, D_b} may solely depend on the temperature, that is, only one data D_m for the modulation current is combined with one data D_b for the bias current to show the preset magnitude and the preset extinction ratio, no plural data D_m may be combined with the target data D_b for the bias current.

Next, a set of combinations {D_m, D_b} (j=1, . . . , n), where the data D_b for the bias current varies by the interval ΔS_b between the minimum, D_{bmin}, and the maximum, D_{bmax}, is selected from the combinations {D_m, D_b} (i=1, . . . , m), where the data D_b optionally varies depending on the temperature. That is, a condition j=1 corresponds to a combination {D_{m1}, D_{bmin}} (j=1), j=2 corresponds to a combination

4

{D_{m2}, D_{bmin}+ΔS_b} (j=2), and so on. Table II below shows an example of thus constructed table {D_m, D_b} (j=1, . . . , n). In the table, D_{b0} is equal to D_{bmin}, D_{b1} is equal to D_{bmin}+ΔS_b, and D_{bn} is equal to D_{bmax}.

TABLE II

Reference Table		
Entry Number	Data for Bias Current	Data for Modulation Current
0	D _{bmin}	D _{m0}
1	D _{bmin} + ΔS _b	D _{m1}
2	D _{bmin} + 2 × ΔS _b	D _{m2}
...
n	D _{bmax}	D _{mn}

Next, the index address of the memory 9 is set, into which the data D_{m0} corresponding to the data D_{bmin} for the bias current is stored. Subsequently, a set of data D_{m1}, D_{m2}, . . . , and D_{mn} for the modulation current is set within the memory as increasing the address thereof by one from the index address.

Thus, in the optical transmitter 1, the memory 9 only stores the set of control data D_m for the modulation current in connection with the bias current D_b but the data D_b is reflected in the address of the memory 9. The current controller 6 only adjusts the data D_b for the bias current based on the photocurrent I_{mon}, and reads the data D_m from the memory corresponding to the data D_b.

Accordingly, the space in the memory 9 for the data D_b may become unnecessary, which makes the circuit of the control unit small. A table III below shows a conventional configuration of the memory to store both sets for the bias current D_b and the modulation current D_m. As acknowledged from the table III, the size of the memory 9 of the present invention may become half of the conventional one where the memory is necessary to store the set of the combinations {D_m, D_b}.

TABLE III

Conventional Configuration	
Address	Data
Index + 0	D _{b0}
Index + 1	D _{m0}
Index + 2	D _{b1}
Index + 3	D _{m1}
...	...
Index + 2n	D _{bn}
Index + 2n + 1	D _{mn}

Moreover, because the feedback loop including the current controller 6, the LD-Driver 3, the LD 2 and the PD 4 only adjusts the bias current I_b, while the modulation current I_m is automatically selected from the memory 9, the time constant of thus feedback loop may be shortened, which stabilizes the optical output O_{out} instantaneously.

Second Embodiment

Next, the second embodiment of the present invention will be described. FIG. 2 shows a block diagram of an optical transmitter 21 according to the second embodiment of the present invention. The optical transmitter 21 has a different configuration from the former transmitter 1 in a point that the control unit 25 constitutes a block to control the bias current in analog.

Specifically, the control unit **25** includes a current controller **30**, a D/A-C **31**, a circuit **26** to control the bias current I_b , a current monitor circuit **27** and an A/D-C **28**. The D/A-C **31** converts the data D_p output from the current controller **30** into an analog signal C_p and provides this analog signal C_p in the analog control unit **32** for the bias current I_b .

The analog control unit **32**, which includes two resistors and a differential circuit, receives a monitored signal V_{mon} converted from the photocurrent I_{mon} by the resistor **10**. The analog control unit **32** generates a control signal C_b , by comparing the signal C_p with the monitored signal V_{mon} , such that the monitored signal V_{mon} becomes equal to the control signal C_b by providing the output C_b to the LD-Driver **3**.

The current monitor unit **27**, by monitoring the bias current I_b output from the LD-Driver **3**, provides the monitored result to the A/D-C **28**, and the A/D-C **28** converts this monitored result into a digital data Db_{mon} .

The control unit **30** generates a data D_p such that the magnitude of the optical output O_{out} becomes a preset value based on data stored in the memory **29**. Further, the current controller **30** is configured to determine the data C_b based on the data Db_{mon} output from the A/D-C **28** and to periodically read the data D_m from the address of the memory **29** that reflects the data C_b . Thus, the current controller **30** periodically adjusts the magnitude of the modulation current I_m .

The memory **29**, same as that shown in Table I, stores a set of data (Dm_0, \dots, Dm_n) in addresses ($index+0, index+1, \dots, index+n$) each corresponding to the set of data from the minimum, Db_{min} , to the maximum, Db_{max} , with a preset interval ΔS_b of the monitored signal Db_{mon} . Thus, the current controller **30** may determine the control data D_m for the modulation current corresponding to the monitored data Db_{mon} for the bias current.

The control unit **25** shown in FIG. 2 further provides a low-pass-filter (LPF) **33** between the D/A-C **31** and the LD-Driver **3**. The time constant of this filter **33** is preferably set to be large enough to escape the feedback loop from being unstable and, at the same time, to satisfy a request for the response time from the DISABLE mode to the ENABLE mode of the transmitter **1**, where the DISABLE mode prevents the operation of the LD by the external command while the ENABLE mode enables to operate the LD by the external command.

The preset table for the modulation current in the memory **29** is constructed as follows:

First, the current controller **30** outputs the data Db such that the magnitude of the optical output O_{out} becomes the preset value at a temperature while the APC loop is suspended. Under the condition above, the data D_m is set, by monitoring the photocurrent I_{mon} , such that the optical output O_{out} shows the preset extinction ratio. An optimal combination of data $\{D_m, Db_{mon}\}$ corresponding to the modulation and bias currents may be thus determined.

Next, a set of optimal combination $\{D_m, Db_{mon}\}$ ($i=1, \dots, m$) is determined as varying the ambient temperature, and combinations $\{D_m, Db_{mon}\}$ ($j=1, \dots, n$) are selected among the combinations $\{D_m, Db_{mon}\}$ ($i=1, \dots, m$) such that the data Db_{mon} changes from the minimum, D_{min} , to the maximum, Db_{max} , with the preset interval, ΔS_b .

The indexed address of the memory **29**, which corresponds to the minimum, Db_{min} , for the monitored signal, is decided and the data Dm_0 for the modulation current is stored therein. Subsequently, the other data Dm_1, Dm_2, \dots, Dm_n for the modulation current are set in the memory as increasing the address of the memory **29** by one.

The optical transmitter **21** may also save the size of the memory **29** to control the bias and modulation currents such

that the optical output O_{out} shows the preset magnitude and the extinction ratio, and may also make the control of the magnitude and the extinction ratio prompt. Moreover, the transmitter **21** shown in FIG. 2 relaxes the throughput of the current controller **30**, because the control unit for the bias current I_b is configured in analog. Still further, the transmitter **21** effectively prevents an excess current from being provided in the LD **2** because of the low-pass-filter between the current controller **30** and the LD-Driver **3**.

Generally, the LD-Driver shows a response so prompt to immediately follow the change of the data, C_m or C_b , from the control unit. For instance, the LD-Driver **3** for the transmission signal faster than 1 Gbps generally has a response time of several nano-seconds to several-tenth nano-seconds, which is far faster than the response of the APC circuit, typically from several micro-seconds to several-tenth micro-seconds. For such LD-Driver, when the power supply is powered on or the operation changes from the DISABLE mode to the ENABLE mode, the bias current I_b first transitions to $I_{BT}+0.5 \times I_{MT}$, where I_{BT} and I_{MT} are the target currents for the bias and modulations current, respectively, and the modulation current starts to flow with a delay by the process carried out in the control unit. Thus, the driving current shows an overshoot at the beginning of the operation, which becomes an excess current flowing in the LD.

When the modulation current I_m does not start to flow, the bias current I_b operates so as to converge to a value greater than the target value I_{BT} and the modulation current I_m is set by referring this miss-converged bias current. Moreover, a digital processing unit installed within an optical transmitter is often restricted in its throughput such that a cycle time thereof is several hundred micro-seconds at most, the process to determine the modulation current I_m refers past bias current. Thus, the driving current shows the overshoot as shown in FIG. 3.

The filter **33** inserted between the control unit **25** and the LD-Driver **3** may suppress this overshoot in the driving current for the LD **2** as shown in FIG. 4, which may effectively prevent the optical output from exceeding the specified limit or the value determined from the safety viewpoint for the laser light, or may protect the LD **2** from being broken down by flowing an excess current. The filter **33** may bring the same function in the case where the optical transmitter **1** according to the first embodiment shown in FIG. 1 installs it.

The present invention is not restricted to those exemplarily described embodiments above. For example, the control unit **6** of the transmitter **1** may set the data as follows: when the measured set of the data $\{D_m, Db\}$ ($i=1, \dots, n$) has an interval in the data Db greater than the preset value ΔS_b , the other set of the data D_m may be calculated by using the interpolation of the sparse data Db . Specifically, when the exact data Db , just corresponding to the value $Db_{min}+(i-1) \times \Delta S_b$, is between one of the measured data Db (k) and the other measured data Db ($k+1$), the current controller **6** may set the desired data D_m by reading the related data D_m (k), D_m ($k+1$) and so on, for the modulation current to interpolate these read out data to obtain the desired data D_m corresponding to the target data Db . Thus, the LD **2** may be further precisely controlled in the magnitude and the extinction ratio of the output thereof.

Moreover, the memory, **9** or **29**, stores the set of data D_m for the modulation current in connection with the bias current Db or the monitored bias current Db_{mon} . However, the memory, **9** or **29**, may hold the set of the data Db for the bias current in connection with the modulation current. In this case, the current controller, **6** or **30**, reads the data Db based on the data D_m for the modulation current, or the monitored data Db_{mon} of the modulation current I_{mon} , respectively. It is

7

therefore intended in the appended claims to cover such modifications that follow in the true spirit and scope of the invention.

I claim:

1. A method for controlling an optical transmitter that includes a laser diode, a photodiode, a driver, and a control unit, the laser diode outputting an optical signal with a predetermined magnitude and a predetermined extinction ratio by receiving modulation and bias currents, the photodiode generating a monitored signal by receiving a portion of the optical signal, the driver controlling the laser diode, the control unit including a memory and a current controller, the memory storing a set of data for the modulation current in a set of addresses in connection with the bias current, the method comprising steps of:

(a) monitoring the photocurrent to generate a monitored signal;

(b) setting a first data for the bias current so as to maintain the monitored signal to be a predetermined level;

(c) setting a second data for the modulation current by reading out from one of addresses in the memory in connection with the first data for the bias current;

(d) providing a set of data including the first data and the second data to the driver from the control unit; and

(e) providing the bias current and the modulation current each determined by the first data and second data, respectively, to the laser diode;

wherein the optical transmitter further includes a low-pass-filter, and

wherein the process for providing the set of data from the control unit to the driver is carried out through the low-pass-filter.

2. A method for controlling an optical transmitter that includes a laser diode, a photodiode, a driver, and a control unit, the laser diode outputting an optical signal with a predetermined magnitude and a predetermined extinction ratio by receiving modulation and bias currents, the photodiode generating a monitored signal by receiving a portion of the optical signal, the driver controlling the laser diode, the control unit including a memory and a current controller, the memory storing a set of data for the modulation current in a set of addresses in connection with the bias current, the method comprising steps of:

(a) monitoring the photocurrent to generate a monitored signal;

(b) setting a first data for the bias current so as to maintain the monitored signal to be a predetermined level;

(c) setting a second data for the modulation current by reading out from one of addresses in the memory in connection with the first data for the bias current;

8

(d) providing a set of data including the first data and the second data to the driver from the control unit; and

(e) providing the bias current and the modulation current each determined by the first data and second data, respectively, to the laser diode;

wherein the addresses of the memory correspond to the bias currents from a minimum to a maximum divided by a predetermined interval, and

wherein the process for setting the first data for the bias current and the process for setting the second data for the modulation current are performed by selecting one of addresses whose corresponding bias current is closest to a current to maintain the monitored signal constant, and by reading a data stored in the selected address of the memory.

3. A method for controlling an optical transmitter that includes a laser diode, a photodiode, a driver, and a control unit, the laser diode outputting an optical signal with a predetermined magnitude and a predetermined extinction ratio by receiving modulation and bias currents, the photodiode generating a monitored signal by receiving a portion of the optical signal, the driver controlling the laser diode, the control unit including a memory and a current controller, the memory storing a set of data for the modulation current in a set of addresses in connection with the bias current, the method comprising steps of:

(a) monitoring the photocurrent to generate a monitored signal;

(b) setting a first data for the bias current so as to maintain the monitored signal to be a predetermined level;

(c) setting a second data for the modulation current by reading out from one of addresses in the memory in connection with the first data for the bias current;

(d) providing a set of data including the first data and the second data to the driver from the control unit; and

(e) providing the bias current and the modulation current each determined by the first data and second data, respectively, to the laser diode;

wherein the addresses of the memory correspond to the bias current from a minimum to a maximum divided by a predetermined interval,

wherein the process for setting the first data for the bias current is performed by setting the first data so as to maintain the monitored signal constant, and

wherein the process for setting the second data for the modulation current is performed by reading a plurality of data from addresses of the memory and by interpolating the read data.

* * * * *