



(12) **DEMANDE DE BREVET CANADIEN
CANADIAN PATENT APPLICATION**

(13) **A1**

(86) **Date de dépôt PCT/PCT Filing Date:** 2022/09/12
 (87) **Date publication PCT/PCT Publication Date:** 2023/03/23
 (85) **Entrée phase nationale/National Entry:** 2024/03/15
 (86) **N° demande PCT/PCT Application No.:** EP 2022/075289
 (87) **N° publication PCT/PCT Publication No.:** 2023/041485
 (30) **Priorité/Priority:** 2021/09/17 (EP21197530.5)

(51) **Cl.Int./Int.Cl. A24F 40/40** (2020.01),
A24F 40/10 (2020.01)
 (71) **Demandeur/Applicant:**
IMPERIAL TOBACCO LIMITED, GB
 (72) **Inventeurs/Inventors:**
AGGARWAL, NIKHIL, GB;
JOHNSON, DEREK, GB
 (74) **Agent:** WILSON LUE LLP

(54) **Titre : DISPOSITIF DE SUBSTITUTION A FUMER**
 (54) **Title: A SMOKING SUBSTITUTE DEVICE**

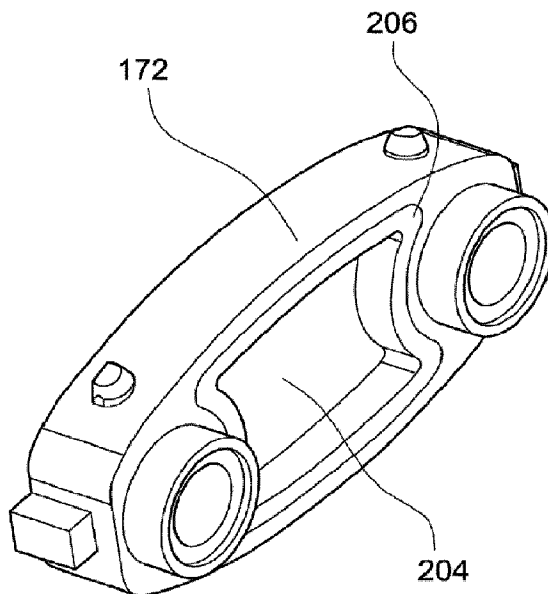

Fig. 9

(57) **Abrégé/Abstract:**

A smoking substitute device is described. The device includes a housing with an upstream airflow inlet, a downstream airflow outlet, and an airflow path connecting the airflow inlet and the airflow outlet. The device also includes a heater for aerosol generation. The heater is located within the airflow path. The airflow inlet is occluded by an air-permeable, liquid-absorbent, blocking element.

Date Submitted: 2024/03/15

CA App. No.: 3231994

Abstract:

A smoking substitute device is described. The device includes a housing with an upstream airflow inlet, a downstream airflow outlet, and an airflow path connecting the airflow inlet and the airflow outlet. The device also includes a heater for aerosol generation. The heater is located within the airflow path. The airflow inlet is occluded by an air-permeable, liquid-absorbent, blocking element.

A SMOKING SUBSTITUTE DEVICE

This application claims priority from EP21197530.5 filed 17 September 2021, the contents and elements of which are herein incorporated by reference for all purposes.

5 Field of the Invention

The present invention relates to a smoking substitute device, and, more particularly but not exclusively, to a smoking substitute device including a heater.

Background

10 The smoking of tobacco is generally considered to expose a smoker to potentially harmful substances. It is generally thought that a significant amount of the potentially harmful substances are generated through the heat caused by the burning and/or combustion of the tobacco and the constituents of the burnt tobacco in the tobacco smoke itself.

Combustion of organic material such as tobacco is known to produce tar and other potentially harmful by-
15 products. There have been proposed various smoking substitute devices in order to avoid the smoking of tobacco.

Such smoking substitute devices can form part of nicotine replacement therapies aimed at people who wish to stop smoking and overcome a dependence on nicotine.

Smoking substitute devices, which may also be known as electronic nicotine delivery systems, may comprise
20 electronic systems that permit a user to simulate the act of smoking by producing an aerosol, also referred to as a "vapour", which is drawn into the lungs through the mouth (inhaled) and then exhaled. The inhaled aerosol typically bears nicotine and/or flavourings without, or with fewer of, the odour and health risks associated with traditional smoking.

In general, smoking substitute devices are intended to provide a substitute for the rituals of smoking, whilst
25 providing the user with a similar experience and satisfaction to those experienced with traditional smoking and tobacco products.

The popularity and use of smoking substitute devices has grown rapidly in the past few years as an aid to assist habitual smokers wishing to quit tobacco smoking. Some smoking substitute devices are designed to resemble a traditional cigarette and are cylindrical in form with a mouthpiece at one end. Other smoking
30 substitute devices do not generally resemble a cigarette (for example, the smoking substitute device may have a generally box-like form).

There are a number of different categories of smoking substitute devices, each utilising a different smoking substitute approach. A smoking substitute approach corresponds to the manner in which the substitute system operates for a user.

One approach for a smoking substitute device is the so-called “vaping” approach, in which a vaporisable liquid, typically referred to (and referred to herein) as “e-liquid”, is heated by a heating device to produce an aerosol vapour which is inhaled by a user. An e-liquid typically includes a base liquid as well as nicotine and/or flavourings. The resulting vapour therefore typically contains nicotine and/or flavourings. The base liquid may include propylene glycol and/or vegetable glycerin.

A typical vaping smoking substitute device includes a mouthpiece, a power source (typically a battery), a tank or liquid reservoir for containing e-liquid, as well as a heating device. In use, electrical energy is supplied from the power source to the heating device, which heats the e-liquid to produce an aerosol (or “vapour”) which is inhaled by a user through the mouthpiece.

Vaping smoking substitute devices can be configured in a variety of ways. For example, there are “closed system” vaping smoking substitute devices which typically have a sealed tank and heating element which is pre-filled with e liquid and is not intended to be refilled by an end user. One subset of closed system vaping smoking substitute devices include a main body which includes the power source, wherein the main body is configured to be physically and electrically coupled to a consumable including the tank and the heating element. In this way, when the tank of a consumable has been emptied, the main body can be reused by connecting it to a new consumable. Another subset of closed system vaping smoking substitute devices are completely disposable, and intended for one-use only.

There are also “open system” vaping smoking substitute devices which typically have a tank that is configured to be refilled by a user, so the device can be used multiple times.

An example vaping smoking substitute device is the myblu™ e-cigarette. The myblu™ e cigarette is a closed system device which includes a main body and a consumable. The main body and consumable are physically and electrically coupled together by pushing the consumable into the main body. The main body includes a rechargeable battery. The consumable includes a mouthpiece, a sealed tank which contains e-liquid, as well as a heating device, which for this device is a heating filament coiled around a portion of a wick which is partially immersed in the e-liquid. The device is activated when a microprocessor on board the main body detects a user inhaling through the mouthpiece. When the device is activated, electrical energy is supplied from the power source to the heating device, which heats e-liquid from the tank to produce a vapour which is inhaled by a user through the mouthpiece.

Another example vaping smoking substitute device is the blu PRO™ e-cigarette. The blu PRO™ e cigarette is an open system device which includes a main body, a (refillable) tank, and a mouthpiece. The main body and tank are physically and electrically coupled together by screwing one to the other. The mouthpiece and refillable tank are physically coupled together by screwing one into the other, and detaching the mouthpiece from the refillable tank allows the tank to be refilled with e-liquid. The device is activated by a button on the main body. When the device is activated, electrical energy is supplied from the power source to a heating device, which heats e-liquid from the tank to produce a vapour which is inhaled by a user through the mouthpiece.

Another approach for a smoking substitute device is the so-called "heat not burn" ("HNB") approach in which tobacco (rather than e-liquid) is heated or warmed to release vapour. The tobacco may be leaf tobacco or reconstituted tobacco. The vapour may contain nicotine and/or flavourings. In the HNB approach the intention is that the tobacco is heated but not burned, i.e. does not undergo combustion.

5 A typical HNB smoking substitute device may include a main body and a consumable. The consumable may include the tobacco material. The main body and consumable may be configured to be physically coupled together. In use, heat may be imparted to the tobacco material by a heating device that is typically located in the main body, wherein airflow through the tobacco material causes moisture in the tobacco material to be released as vapour. A vapour may be formed from a carrier in the tobacco material (this carrier may for
10 example include propylene glycol and/or vegetable glycerin) and additionally volatile compounds released from the tobacco. The released vapour may be entrained in the airflow drawn through the tobacco.

As the vapour passes through the smoking substitute device (entrained in the airflow) from an inlet to a mouthpiece (outlet), the vapour cools and condenses to form an aerosol (also referred to as a vapour) for inhalation by the user. The aerosol will normally contain the volatile compounds.

15 In HNB smoking substitute devices, heating as opposed to burning the tobacco material is believed to cause fewer, or smaller quantities, of the more harmful compounds ordinarily produced during smoking. Consequently, the HNB approach may reduce the odour and/or health risks that can arise through the burning, combustion and pyrolytic degradation of tobacco.

In prior art smoking substitute devices, some of the unvaporized e-liquid may leak out from the device due to
20 leakage paths present between the components of the consumable. Additionally, it is desirable to provide consumables which are easier and cheaper to manufacture.

The present invention has been devised in light of the above considerations.

Summary of the Invention

25 According to a first aspect, there is provided a smoking substitute device including a housing, housing including: an upstream airflow inlet, a downstream airflow outlet, and an airflow path connecting the airflow inlet and the airflow outlet; a heater for aerosol generation, wherein the heater is located within the airflow path; wherein the airflow inlet is occluded by an air-permeable, liquid-absorbent, blocking element. In such arrangements, leakage of aerosol forming substrate via the airflow inlet may be reduced.

30

Optionally, the blocking element is located upstream of the heater. In such arrangements, aerosol forming substrate leakage may be further mitigated from an upstream location of the heater, this is aerosol forming substrate that may leak from the heater to the airflow inlet, which is against the normal airflow direction, which is more likely to occur when the user is not drawing on the device.

35

Optionally, the airflow inlet comprises an arrangement of a plurality of airflow sub-inlets. In such arrangements, the airflow sub-inlets may be help to retain the blocking element in position.

Optionally, the housing includes an upstream end cap, and wherein the end cap comprises the blocking element. In such arrangements, the manufacture of the device may be simplified since the end cap and the blocking element may be assembled separately.

5

Optionally, the blocking element comprises a porous material. In such arrangements, the properties of the blocking element can be suitable for both airflow permeability and liquid absorbance.

Optionally, the blocking element is located in a cavity in the housing, the airflow inlet being formed in a base
10 of the cavity. In such embodiments, the blocking element may be reliably retained in the housing. Such
embodiments may also simplify manufacture since the cavity provides a defined location for the blocking
element.

Optionally, the cavity includes a peripheral wall having a cavity wall shape; wherein the cavity wall shape
15 conforms to a shape of the blocking member. Such arrangements may improve performance of the device
since the cavity wall may reduce the potential for movement of the blocking element once it is in place.

Optionally, the device includes a retaining frame to hold the blocking member in the housing. Such
embodiments may improve performance of the device since the frame may reduce the potential for
20 movement of the blocking element once it is in place.

Optionally, the retaining frame abuts the peripheral wall to thereby retain the blocking member in the cavity.
Such embodiments may improve performance of the device since the frame being closely retained in the
cavity may reduce the potential for movement of the frame and the blocking element once they are in place.

25

Optionally, the retaining frame includes a frame airflow opening, wherein the frame airflow opening has a
cross-sectional area for airflow that is equal to, or larger than, a cross-sectional area for airflow of the airflow
inlet. In such embodiments, the airflow cross section may not be dictated by the frame, which may improve
device aerosol generation performance. In the case that the frame opening is larger, this may expose more
30 of the blocking element for absorbing liquid, which may improve the leakage performance of the device.

Optionally, the housing includes a pair of electrode access passages adjacent the airflow inlet, each
electrode access passage including an upstream opening and a downstream opening. In such embodiments,
the electrode access passages being adjacent the inlet, and thus the blocking element, may reduce leakage
35 via the electrode access passages.

Optionally, the blocking element is located upstream of the downstream openings. In such embodiments,
leakage may be further reduced because the openings of the electrodes access passages are above (or
downstream of) the blocking element.

40

Optionally, the heater is substantially planar. In such embodiments, the blocking element may be particularly advantageous because the plane of the planar heater is a point of potential liquid egress from the heater, and thus a source of potential leakage.

- 5 Optionally, the blocking element is substantially planar. In such embodiments, the blocking element may provide a larger surface area for liquid absorbing, which may reduce leakage.

Optionally, a major plane of the planar heater is substantially parallel to a major plane of the blocking element. In such embodiments, leakage may be reduced.

10

According to a second aspect, there is provided a smoking substitute system including a smoking substitute device according to the first aspect, and a main body device including the power supply, wherein the main body device and substitute smoking device are configured for mutual engagement to bring the electrodes into electrical contact with the heater.

- 15 The invention includes the combination of the aspects and preferred features described except where such a combination is clearly impermissible or expressly avoided.

Summary of the Figures

So that the invention may be understood, and so that further aspects and features thereof may be appreciated, embodiments illustrating the principles of the invention will now be discussed in further detail

20 with reference to the accompanying figures, in which:

Figure 1a is a side view of a smoking substitute device according to an embodiment;

Figure 1b is a side view of main body of the smoking substitute device according to an embodiment;

Figure 1c is a side view of consumable of the smoking substitute device according to an embodiment;

Figure 2a is a schematic drawing of the main body according to an embodiment;

25 **Figure 2b** is a schematic drawing of the consumable according to an embodiment;

Figure 3 is a cross-section of the consumable according to an embodiment;

Figure 4 is a perspective end view of the consumable of Fig. 3;

Figure 5 is a cross section of a portion of the consumable of Figs. 3 and 4;

Figure 6a is a perspective view of a portion of the consumable according to an embodiment;

30 **Figure 6b** is a perspective view of a portion of the consumable according to an embodiment;

Figure 7 is a perspective end view of a consumable according to an embodiment;

Figure 8 is a perspective end view of a consumable according to an embodiment;

Figure 9 is a perspective view of a portion of a consumable according to an embodiment; and

Figure 10 is a perspective view of a portion of a consumable according to an embodiment.

Detailed Description of the Invention

Aspects and embodiments of the present invention will now be discussed with reference to the
5 accompanying figures. Further aspects and embodiments will be apparent to those skilled in the art. All documents mentioned in this text are incorporated herein by reference.

Figure 1a shows a smoking substitute system 110. In this example, the smoking substitute system 110 includes a main body 120 and a consumable 150. The consumable 150 may alternatively be referred to as a "pod". The consumable 150 may also be referred to as a cartridge or cartomizer. In other examples, the
10 terms "aerosol delivery device" or "smoking substitute device" may refer to the consumable 150 alone rather than the combination of the main body 120 and the consumable 150.

In this example, the smoking substitute system 110 is a closed system vaping device, wherein the consumable 150 includes a sealed tank or liquid reservoir 156 and is intended for one-use only.

Figure 1a shows the smoking substitute system 110 with the main body 120 physically coupled to the
15 consumable 150.

Figure 1b shows the main body 120 of the smoking substitute system 110 without the consumable 150.

Figure 1c shows the consumable 150 of the smoking substitute system 110 without the main body 120.

The main body 120 and the consumable 150 are configured to be physically coupled together, in this example by pushing the consumable 150 into an aperture in a top end 122 of the main body 120, such that
20 there is an interference fit between the main body 120 and the consumable 150. In other examples, the main body 120 and the consumable could be physically coupled together by screwing one onto the other, or through a bayonet fitting, for example. An optional light 126, e.g. an LED, located behind a small translucent cover, is located a bottom end 124 of the main body 120. The light 126 may be configured to illuminate when the smoking substitute system 110 is activated.

25 The consumable 150 includes a mouthpiece (not shown in Fig. 1a-c) at a top end 152 of the consumable 150, as well as one or more air inlets (not shown) so that air can be drawn into the smoking substitute system 110 when a user inhales through the mouthpiece. At a bottom end 154 of the consumable 150, there is located a tank 156 that contains e-liquid. The tank 156 may be a translucent body, for example.

The tank 156 preferably includes a window 158, so that the amount of e-liquid in the tank 156 can be visually
30 assessed. The main body 120 includes a slot 128 so that the window 158 of the consumable 150 can be seen whilst the rest of the tank 156 is obscured from view when the consumable 150 is inserted into the aperture in the top end 122 of the main body 120.

The tank 156 may be referred to as a "clearomizer" if it includes a window 158, or a "cartomizer" if it does not.

The consumable 150 may identify itself to the main body 120, via an electrical interface, RFID chip, or barcode.

Figure 2a is a schematic drawing of the main body 120 of the smoking substitute device 110.

Figure 2b is a schematic drawing of the consumable 150 of the smoking substitute device 110.

5 As shown in Figure 2a, the main body 120 includes a power source 128, a control unit 130, a memory 132, a wireless interface 134, an electrical interface 136, and, optionally, one or more additional components 138.

The power source 128 is preferably a battery, more preferably a rechargeable battery.

The control unit 130 may include a microprocessor, for example.

The memory 132 is preferably includes non-volatile memory. The memory may include instructions which,
10 when implemented, cause the control unit 130 to perform certain tasks or steps of a method.

The wireless interface 134 is preferably configured to communicate wirelessly with another device, for example a mobile device, e.g. via Bluetooth®. To this end, the wireless interface 134 could include a Bluetooth® antenna. Other wireless communication interfaces, e.g. WiFi®, are also possible. The wireless interface 134 may also be configured to communicate wirelessly with a remote server.

15 The electrical interface 136 of the main body 120 may include one or more electrical contacts. The electrical interface 136 may be located in, and preferably at the bottom of, the aperture in the top end 122 of the main body 120. When the main body 120 is physically coupled to the consumable 150, the electrical interface 136 may be configured to pass electrical power from the power source 128 to (e.g. a heating device of) the consumable 150 when the smoking substitute system 110 is activated, e.g. via the electrical interface 160 of
20 the consumable 150 (discussed below). The electrical interface 136 may be configured to receive power from a charging station, when the main body 120 is not physically coupled to the consumable 150 and is instead coupled to the charging station. The electrical interface 136 may also be used to identify the consumable 150 from a list of known consumables. For example, the consumable may be a particular flavour and/or have a certain concentration of nicotine. This can be identified to the control unit 130 of the
25 main body 120 when the consumable is connected to the main body 120. Additionally, or alternatively, there may be a separate communication interface provided in the main body 120 and a corresponding communication interface in the consumable 150 such that, when connected, the consumable can identify itself to the main body 120.

The additional components 138 of the main body 120 may comprise the optional light 126 discussed above.

30 The additional components 138 of the main body 120 may, if the power source 128 is a rechargeable battery, comprise a charging port configured to receive power from the charging station. This may be located at the bottom end 124 of the main body 120. Alternatively, the electrical interface 136 discussed above is configured to act as a charging port configured to receive power from the charging station such that a separate charging port is not required.

The additional components 138 of the main body 120 may, if the power source 128 is a rechargeable battery, include a battery charging control circuit, for controlling the charging of the rechargeable battery. However, a battery charging control circuit could equally be located in the charging station (if present).

The additional components 138 of the main body 120 may include an airflow sensor for detecting airflow in
5 the smoking substitute device 110, e.g. caused by a user inhaling through a mouthpiece 166 (discussed below) of the smoking substitute system 110. The smoking substitute system 110 may be configured to be activated when airflow is detected by the airflow sensor. This optional sensor could alternatively be included in the consumable 150 (though this is less preferred where the consumable 150 is intended to be disposed of after use, as in this example). The airflow sensor can be used to determine, for example, how heavily a
10 user draws on the mouthpiece or how many times a user draws on the mouthpiece in a particular time period.

The additional components 138 of the main body 120 may include an actuator, e.g. a button. The smoking substitute system 110 may be configured to be activated when the actuator is actuated. This provides an alternative to the airflow sensor noted, as a mechanism for activating the smoking substitute system 110.

15 As shown in Figure 2b, the consumable 150 includes the tank 156, an electrical interface 160, a heating device 162, one or more air inlets 164, a mouthpiece 166, and, optionally, one or more additional components 168. The consumable 150 includes a heater chamber 170, which contains the heating device 162.

The electrical interface 160 of the consumable 150 may include one or more electrical contacts. In an
20 embodiment, the electrical contacts may each be considered as parts of the heating device 162. The electrical interface 136 of the main body 120 and an electrical interface 160 of the consumable 150 are preferably configured to contact each other and thereby electrically couple the main body 120 to the consumable 150 when the bottom end 154 of the consumable 150 is inserted into the top end of the main body 122 (as shown in Fig. 1a, see also Fig. 3) to physically couple the consumable 150 to the main body
25 120. In this way, electrical energy (e.g. in the form of an electrical current) is able to be supplied from the power source 128 in the main body 120 to the heating device 162 in the consumable 150.

The heating device 162 is preferably configured to heat e-liquid sourced from the tank 156, e.g. using electrical energy supplied from the power source 128, in order to vaporise the e-liquid. The tank 156 is an example of a store for supplying aerosol forming substrate (e.g. e-liquid) to the heating device 162.

30 The one or more air inlets 164 are preferably configured to allow air to be drawn into the smoking substitute system 110, when a user inhales through the mouthpiece 166. When the consumable 150 is physically coupled to the main body 120, the air inlet 164 receives air which flows from the top end 122 of the main body 120, between the main body 120 and the bottom end 154 of the consumable 150.

In use, a user activates the smoking substitute device 110, e.g. through actuating an actuator included in the
35 main body 120 or by inhaling through the mouthpiece 166 as described above. Upon activation, the control unit 130 may supply electrical energy from the power source 128 to the heating device 162 (via electrical

interfaces 136, 166), which may cause the heating device 162 to heat e-liquid drawn from the tank 156 to produce a vapour / aerosol which is inhaled by a user through the mouthpiece 166.

As an example of one of the one or more additional components 168, an interface for obtaining an identifier of the consumable may be provided. As discussed above, this interface may be, for example, an RFID
5 reader, a barcode or QR code reader, or an electronic interface which is able to identify the consumable to the main body 120. The consumable 150 may, therefore include any one or more of an RFID chip, a barcode or QR code, or memory within which is an identifier and which can be interrogated via the electronic interface in the main body 120.

Of course, a skilled reader would readily appreciate that the smoking substitute system 110 shown in Figs. 1
10 and 2 shows just one example implementation of a smoking substitute system, and that other forms of smoking substitute system could be used.

As another example, an entirely disposable (one use) smoking substitute system could be used as the smoking substitute system. Figure 3 shows a cross-sectional view of a consumable 150 according to an embodiment. The consumable 150 is an example of a smoking substitute device.

15 The consumable 150 includes a tank 156 for storing aerosol forming substrate (e.g. e-liquid). In the embodiment of Figure 4, the tank 156 is an annular tank. An airflow tube 157 passes through the tank 156. The airflow tube 157 forms a portion of the airflow path through the consumable 150. At an upstream end of the airflow path there is an airflow inlet 164. At a downstream end of the airflow path there is an airflow outlet
20 out from the consumable 150 at the airflow outlet 168, which is located in the mouthpiece 166 of the consumable 150.

Within the airflow path is the heating device 162. The heating device 162 includes a wick heater 170. The wick heater 170 is so called because the wick heater 170 is a combined wick and heater component. That is, the wick heater 170 is a component that is configured to convey / store aerosol forming substrate within or
25 on itself and which is also configured to be heated to vaporize at least a portion of the aerosol forming substrate contained within or on the wick heater 170. In the embodiment the aerosol forming substrate is a liquid, and in particular an e-liquid.

The wick heater 170 is formed from a porous electrically conductive fabric, e.g. a fabric including carbon fibres. The electrically conductive fabric may be a sheet of electrically conductive fabric. The electrical
30 conductivity of such a fabric wick heater 170 allows the e-liquid within the pores of the wick heater 170 to be heated and consequently vaporized via resistive heating of the wick heater 170 when electrical current is passed through the wick heater 170. The porosity of the wick heater 170 enables the wick heater 170 to wick or convey, and retain, the e-liquid within or on the wick heater 170. The pores of the wick heater 170 may be interstices within the fabric (e.g. between the fibres and/or yarns of the fabric).

35 The wick heater 170 is generally elongate. In other words, the wick heater 170 has a longer longitudinal major axis and a relatively shorter minor transverse axis. The wick heater 170 also a depth. The depth may be less than the width.

In some embodiments, the wick heater 170 is generally planar. The wick heater 170 thereby has a major plane, which may correspond to the surface of the wick heater 170 having the largest surface area. When the wick heater 170 is located within the consumable 150, the major plane is not necessarily flat across the whole of the wick heater 170. In some embodiments, at least a portion of the major plane of the wick heater 5 170 may be curved or bent, for example along at least a portion of the major and/or minor axes of the wick heater 170 itself.

The wick heater 170 is electrically engageable with the power source 128 (see Fig. 2a) via the electrical interface 136 of the main body 120. In the embodiment, this engagement occurs when the consumable 150 is engaged with the main body 120. During such engagement, two power supply electrodes of the electrical 10 interface 136 of the main body 120 intrude into a pair of electrical contact holes 171 formed through an upstream end cap 172 of the consumable 150. The power supply electrodes thereby electrically engage with the wick heater 170.

In some embodiments the end cap 172 also effectively seals the tank 156. During manufacture, the end cap 172 may be applied to the rest of the consumable 150 after the tank 156 has been filled with aerosol forming 15 substrate.

The wick heater 170 spans across a heater chamber 174. The wick heater 170 is partially suspended within the heater chamber 174 such that there is empty space either upstream, downstream or both, of at least a portion of the wick heater 170. In use, air flows along the airflow path, in which at least a portion of the wick heater 170 is located. When passing through the heater chamber 174 (which also forms part of the airflow 20 path), vapour / aerosol (herein referred to only as aerosol) is entrained into the airflow from the wick heater 170. The aerosol is conveyed downstream to the airflow outlet 168 by the airflow, and, ultimately, to the user for inhalation.

The airflow inlet 164 opens, in a downstream direction, into the heater chamber 174. The airflow inlet 164 includes an array of airflow sub-inlets 176. In general, when a user inhales on the airflow outlet 168, air will 25 be drawn into the flow path via the airflow sub-inlets 176 generally simultaneously. Each airflow sub-inlet 176 is the opening to a sub-inlet passageway 177 that passes through the upstream end cap 172 of the consumable 150. In some embodiments, and as illustrated, the sub-inlet passageways 177 are generally parallel to one another. The sub-inlets passageways 177 themselves form a portion of the airflow path through the consumable 150. The downstream end of each sub-inlet passageway forms an opening in to the 30 heater chamber 174.

Downstream of the airflow sub-inlets passageways 177, and within the heater chamber 174, the airflow within the flow path 12 combines into a unitary airflow. The peripheral cross sectional shape of the unitary airflow downstream of the sub-inlet passageways 177, and thus the airflow impinging upon the wick heater 170 (and in particular upon the heating portion of the wick heater 170), may be controlled at least in part by 35 the features of the airflow sub-inlets 176 and sub inlet passageways 177. By controlling number, size, and/or locations of the airflow sub inlets 176 and sub inlet passageways 177, the airflow impingent on the wick heater 170 may be controlled to improve vaporisation characteristics from the wick heater 170. For example, in general airflow incident on to a heater may give rise to a cooling effect on the heater. This may be

particularly pronounced for a planar heater, which may form a substantially non-aerodynamic object in the flow path. With only a single airflow inlet, that cooling effect may be localised in an area of the heater at which the incoming airflow is incident. This may give rise to cold spot on the heater, and to inefficient vaporisation from the heater.

5 By extending the area of the impinging airflow across a larger portion of the wick heater 170 via the sub-inlets 176, any consequent cooling effect can be spread across a larger area of the wick heater 170, reducing the local cooling effect at any one point on the wick heater 170. One might consider that a single large airflow inlet aligned with a large area of the wick heater 170 may mitigate this localised cooling issue. However, such a single large airflow inlet may be undesirable because of the risks of foreign object damage
10 to the internal areas of the apparatus via such an airflow inlet, and in particular, the risk of damage to the heater. A large inlet may also be a potential inlet for detritus. Furthermore, a large single airflow inlet may increase the risk of leakage of aerosol forming substrate from the apparatus via that outlet. On the other hand, using the airflow sub-inlets 176 is a compromise between reducing the risk of damage or contamination, mitigating local cooling effects of the heater 170, and reducing leakage from the consumable
15 150.

Provision of the sub-inlets 176 may also lead to a reduced local airflow velocity over the wick heater 170. This may lead to an increased aerosol particle size produced by the consumable 150. Larger aerosol particle sizes may result in more efficient delivery of an active ingredient (e.g. nicotine) to the user.

In some embodiments, the consumable 150 may include at least 3 airflow sub inlets 176, more preferably at
20 least 6 airflow sub inlets 176, more preferably at least 10 airflow sub-inlets 176.

A typical opening size of a single airflow sub-inlet 176 may be between 0.1 millimetres and 1.0 millimetres, preferably between 0.3 millimetres and 0.5 millimetres. In other embodiments the typical opening size may be smaller than 0.1 millimetres. In some embodiments, each airflow sub-let 176 leads to a sub inlet passageway 177 of constant cross sectional shape. In some embodiments, the cross sectional shape of
25 each airflow sub-inlet 176 and sub inlet passageway 177 may be generally circular.

In some embodiments, all of the airflow sub-lets 176 have a substantially identical size. In some other embodiments, the airflow sub-inlets 176 may include airflow sub-inlets 176 of differing sizes. For example, at least one of the airflow sub-inlets 176 may be larger than another of the airflow sub-inlets 176. In some
30 embodiments, the airflow sub-inlets 176 include at least two populations of airflow sub-inlets, wherein each airflow sub-inlet population includes at least one airflow sub-inlet of a particular size. The size of the airflow sub-inlets 176 may differ between populations. In this way, the airflow profile onto the wick heater 176 may be further optimised by controlling the airflow sub-inlet size and position distributions.

In some embodiments, the plane of the airflow sub-inlets 176 may be generally parallel to the major plane of the wick heater 170. That is, a plane containing the sub inlets 176 may be generally parallel to the major
35 plane of the wick heater 170. The sub inlet passageways 177 may be generally perpendicular to the major plane of the wick heater 170.

In some embodiments, the distance between (i.e. the separation between) the downstream outlets of the airflow sub-inlets passageways 177 and the wick heater 170 may be less than 10 millimetres, preferably between 1 millimetre and 10 millimetres, more preferably between 1 millimetre and 5 millimetres. This distance may be controlled to change the parameters of the airflow incident upon the wick heater 170. For example, a small separation may lead to a plurality of relatively distinct airflows from respective sub-inlets passageways 177 incident on the wick heater 170. A larger separation may lead to a more unitary, uniform, airflow incident on the wick heater 170 as the individual airflows from the sub-inlet passageways 177 merge into one airflow downstream of the sub-inlet passageways 177.

Figure 4 shows an alternate view of the consumable 150 of Figure 3. The airflow sub-inlets 176 are visible on the upstream end of the consumable 150, and in particular on the end cap 172 of the consumable 150. The airflow sub-inlets 176 are distributed in a 2 dimensional array. The array of the airflow sub-inlets 176 is bounded by an array shape. In the embodiment of Fig. 5, the array shape is a rectangle. In other embodiments, the array shape may be different. The array shape may be a polygon, for example a square, rectangle or diamond shape. In other examples, the array shape may be oval or circular, or any other suitable shape.

The sub-inlets 176 may cover at least a coverage fraction of the array shape. In other words, at least the coverage fraction of the surface area of the array shape may be a sub-inlet 176. The coverage fraction may be 20%, more preferably 30%, more preferably 40%, more preferably 50%, more preferably 60%, more preferably 70%, more preferably 80%.

The array shape may have a surface area of at least 6mm^2 , more preferably at least 8mm^2 , more preferably at least 10mm^2 , more preferably at least 12mm^2 , more preferably at least 14mm^2 , more preferably at least 16mm^2 , more preferably at least 18mm^2 .

The airflow sub-inlets 176 are located between the electrical contact holes 171. In other words, the electrical contact holes are located laterally outwards of the airflow sub-inlets 176. The electrical contact holes 171 are also formed through the end cap 172.

Fig. 5 shows a detailed view of the upstream section of the consumable 150. The consumable 150 is illustrated in engagement with a pair of electrical supply pins 178 (examples of electrical supply electrodes). The electrical supply pins 178 are part of the electrical interface 136 of the main body 120. The electrical supply pins 178 extend into the end cap 172 through the pair of electrical contact holes 171. The upper (i.e. downstream) surfaces of the electrical supply pins 178 are brought into electrical contact with a respective conductive disc 180. In turn the each electrical contact disc 180 makes electrical contact with a respective electrical connection region of the wick heater 170. Thus, electrical current can flow between the supply pins 178, via the electrical contact discs 180 and via the wick heater 170. The wick heater 170 is thus heated via resistive, or Ohmic, heating.

Each of the supply pins 178 include an upwardly directed flat face for co-planar engagement with the upstream surface of the respective electrical contact disc 180. By co-planar it is meant that the plane of the flat face abuts the plane of the upstream surface of the electrical contact disc 180. The supply pin 178 having

the flat face may increase the reliability of electrical connection between the wick heater 170 and the supply pins 178 relative to a pointed pogo pin. In particular contact resistance between supply pins 178 and wick heater 170 may be reduced. The flat face may have a flat surface area of between 0.1mm^2 and 250mm^2 . More preferably between about 3 and 40mm^2 , more preferably between about 5 and 20mm^2 .

5 Figure 6a and 6b each show a view of the end cap 172. In Figure 6b, the electrical contact discs 180 are located in a pair of respective retaining disc cavities 182. In Figure 6a, the electrical contact discs are absent to illustrate the retaining disc cavities 182.

Each disc cavity 182 is formed from a respective peripheral wall surrounding a ledge on which the peripheral edge of the respective electrical contact disc 180 sits. The ledge is formed by the downstream opening of the
10 electrical contact holes 171. The peripheral wall surrounds the downstream opening of the corresponding electrical contact hole 171. As such, when in place (i.e. as shown in Fig. 6b) the electrical contact disc 180 is suspended over the downstream opening of the electrical contact hole 171. The height of the peripheral wall above the peripheral ledge may be greater than a depth of the electrical contact disc 180 seated therein. This means that the electrical contact disc 180 is moveable within its respective disc cavity 182 along a
15 longitudinal axis of the consumable 150. The contact disc 180 is retained laterally in position by the peripheral wall of the cavity 182. Because the electrical contact discs 180 are movable, they are pushed into electrical contact with the wick heater 170 by the electrical supply pins 178.

This means that during the manufacturing process, no permanent electrical connection need be formed between the contact discs 180 and the wick heater 170. Furthermore, the manufacturing tolerances of the
20 consumable 150 can be lower, improving manufacturability. In particular, because reliable electrical contact is made by the action of the supply pins 178 on the contact discs 180, spring mounted supply pins 178 for example can ensure reliable electrical connection from power supply to heater, rather than relying on a fixed, rigid, or permanent connection, which may weaken over time, or may be difficult to manufacture reliably.

The electrical contact discs 180 (i.e. an embodiment of bridging elements) are electrically conductive. For
25 example, the electrical contact discs are formed with or from a metallic material. In some embodiments the contact discs 180 are formed with or from silver. In some embodiments, the electrical contact discs 180 are formed from a foil.

Figures 6a and 6b illustrate that the disc cavity is longitudinally displaced from the downstream openings of the sub inlets passageways 177. This displacement may control the location of the wick heater 170, which
30 may be situated immediately downstream of the tops of the disc cavity walls. The disc cavity walls may therefore longitudinally displace the wick heater 170 so that the wick heater 170 is located downstream and separated from the downstream openings of the sub inlet passageways 177 (or in general from any airflow inlet). The wick heater 170, in use, may contain liquid aerosol forming substrate. The sub inlet passageways 177 (or in general any airflow inlet) are a potential leakage path out from the consumable 150 of aerosol
35 forming substrate. As such, it may be beneficial to maintain a separation between the wick heater 170 and the sub inlet passageways 177 (or in general any airflow inlet).

In the embodiment of Figs. 6a and 6b the electrical contact discs 180 are circular. This may improve manufacturability because there may be no preferred orientation to be achieved before placement of the contact discs 180 into the end cap 172 during manufacturer. In other embodiments, the bridging elements may be other shapes (e.g. polygonal).

5 Fig. 7 shows another embodiment of a consumable 200. The consumable 200 may be similar in many respects to the embodiments of Figs. 5, 6a and 6b, and to consumable 150 in particular. Where appropriate like reference numerals are used.

The consumable 200 also includes an end cap 172. The end cap 172 includes a single, centrally located airflow inlet 202. The airflow inlet 202 has a generally oval shape, in which the narrower ends of oval are
10 convex. In some embodiments, the airflow inlet 202 may be replaced with the airflow sub inlets 176, which are described above in respects of Figs. 4 and 5. The end cap 172 includes a pair of electrical contact holes 171 for the access of the electrical pins 178 of the main body 120 to the heater, which is located within the consumable 200. In some embodiments, the heater is a wick heater 170 of the sort described above.

The airflow inlet 202 is located between the electrical contact holes 171. The electrical contact holes 171 are
15 adjacent the convex ends of the airflow inlet 202. The airflow inlet 202 is an opening in the end cap 172, through which air enters the consumable 200. The airflow inlet 202 is covered by a porous pad 204, which is located within the end cap 172. The porous pad 204 is an example of a blocking element. In the embodiment of Fig. 7, the porous pad 204 is visible through the airflow inlet 202. The porous pad 204 is permeable to
20 airflow. The porous pad 204 is absorbent. The porous pad 204 may be formed, for example, from cellulose acetate or cotton.

Fig. 8 shows a variation of the consumable 200. The consumable 200 of Fig. 8 has a circular airflow aperture 202 located between electrical contact holes 171.

Fig. 9 shows an internal view of the end cap 172 of Fig. 7. The porous pad 204 is located within a recess of corresponding size and shape, the recess being formed within the end cap 172 on a downstream side of the
25 end cap 172. The porous pad 204 has depth that is less than the depth of the recess. The porous pad 204 is retained in place by a retaining frame 206, which is located downstream of the porous pad 204, and which engages with the peripheral side wall of the recess. The frame 206 includes an opening through which air can flow. The opening in the frame 206 is downstream of the airflow inlet (not visible in Fig. 8), and downstream of the porous pad 204. The airflow aperture 202 may be smaller and / or a different shape from
30 the opening in the end cap 172 for receipt of the frame 206. This may provide a ledge on which the porous pad 204 sits. The frame 206 retains the porous pad 204 against the ledge formed by the airflow opening 202 in the end cap 172. The airflow aperture 202 in the end cap 172 is positioned within the perimeter of the aperture of the frame 206.

The porous pad 204 is permeable to airflow, so that air may enter the consumable 200 when the user draws
35 on the mouthpiece. The porous pad 204 is also absorbent for liquids. Accordingly, the porous pad 204 may absorb liquid aerosol forming substrate which might otherwise leak from the consumable 200 via the airflow aperture 202. Undesirable leakage from the consumable 200 may thereby be reduced. The porous pad 204

may cover at least 50% of a total transverse area of the consumable 200. A larger porous pad 204 may be capable of absorbing a greater amount of liquid, which may thus reduce leakage from the consumable 200.

Fig. 10 shows an internal view of the end cap 172 of Fig. 9. The porous pad 204 is located within a recess of corresponding size and shape, the recess being formed within the end cap 172 on a downstream side of the
5 end cap 172. The porous pad 204 has depth that is less than the depth of the recess. The porous pad 204 is retained in place by a retaining frame 206, which is located downstream of the porous pad 204, and which engages with the peripheral side wall of the recess. The frame 206 includes an opening through which air can flow. The opening in the frame 206 is downstream of the airflow inlet (not visible in Fig. 10), and downstream of the porous pad 204. In the embodiment of Fig. 10, the airflow aperture in the frame 206 is
10 circular. This provides a ledge on which the porous pad 204 sits. The frame 206 is then retaining the porous pad 204 against the ledge formed by the airflow opening 202 in the end cap 172. The aperture of the frame 206 is aligned with the airflow aperture 202 in the end cap 172. The airflow aperture 202 has a diameter of 3.5mm. In some embodiments, the airflow aperture has a diameter between 2.0 and 5.0 millimetres, more preferably between 3.0 and 4.0 millimetres.

15 The features disclosed in the foregoing description, or in the following claims, or in the accompanying drawings, expressed in their specific forms or in terms of a means for performing the disclosed function, or a method or process for obtaining the disclosed results, as appropriate, may, separately, or in any combination of such features, be utilised for realising the invention in diverse forms thereof.

While the invention has been described in conjunction with the exemplary embodiments described above,
20 many equivalent modifications and variations will be apparent to those skilled in the art when given this disclosure. Accordingly, the exemplary embodiments of the invention set forth above are considered to be illustrative and not limiting. Various changes to the described embodiments may be made without departing from the spirit and scope of the invention.

For the avoidance of any doubt, any theoretical explanations provided herein are provided for the purposes
25 of improving the understanding of a reader. The inventors do not wish to be bound by any of these theoretical explanations.

Any section headings used herein are for organizational purposes only and are not to be construed as limiting the subject matter described.

Throughout this specification, including the claims which follow, unless the context requires otherwise, the
30 words "have", "comprise", and "include", and variations such as "having", "comprises", "comprising", and "including" will be understood to imply the inclusion of a stated integer or step or group of integers or steps but not the exclusion of any other integer or step or group of integers or steps.

It must be noted that, as used in the specification and the appended claims, the singular forms "a," "an," and "the" include plural referents unless the context clearly dictates otherwise. Ranges may be expressed herein
35 as from "about" one particular value, and/or to "about" another particular value. When such a range is expressed, another embodiment includes from the one particular value and/or to the other particular value. Similarly, when values are expressed as approximations, by the use of the antecedent "about," it will be

understood that the particular value forms another embodiment. The term "about" in relation to a numerical value is optional and means, for example, +/- 10%.

The words "preferred" and "preferably" are used herein refer to embodiments of the invention that may provide certain benefits under some circumstances. It is to be appreciated, however, that other embodiments 5 may also be preferred under the same or different circumstances. The recitation of one or more preferred embodiments therefore does not mean or imply that other embodiments are not useful, and is not intended to exclude other embodiments from the scope of the disclosure, or from the scope of the claims.

Claims:

1. A smoking substitute device including a housing, housing including:
an upstream airflow inlet, a downstream airflow outlet, and an airflow path connecting the airflow
5 inlet and the airflow outlet;
a heater for aerosol generation, wherein the heater is located within the airflow path;
wherein the airflow inlet is occluded by an air-permeable, liquid-absorbent, blocking element.
2. A smoking substitute device according to claim 1, wherein, the blocking element is located
10 upstream of the heater.
3. A smoking substitute device according to claim 1 or claim 2, wherein the airflow inlet comprises
an arrangement of a plurality of airflow sub-inlets.
- 15 4. A smoking substitute device according to any preceding claim, wherein the housing includes an
upstream end cap, and wherein the end cap comprises the blocking element.
5. A smoking substitute device according to any preceding claim, wherein the blocking element
comprises a porous material.
20
6. A smoking substitute device according to any preceding claim, wherein the blocking element is
located in a cavity in the housing, the airflow inlet being formed in a base of the cavity.
7. A smoking substitute device according to claim 6, wherein the cavity includes a peripheral wall
25 having a cavity wall shape; wherein the cavity wall shape conforms to a shape of the blocking member.
8. A smoking substitute device according to any preceding claim, wherein the device includes a
retaining frame to hold the blocking member in the housing.
- 30 9. A smoking substitute device according to claim 8, as dependent on claim 7, wherein the retaining
frame abuts the peripheral wall to thereby retain the blocking member in the cavity.
10. A smoking substitute device according to claim 8 or claim 9, wherein the retaining frame includes
a frame airflow opening, wherein the frame airflow opening has a cross-sectional area for airflow that is
35 equal to, or larger than, a cross-sectional area for airflow of the airflow inlet.
11. A smoking substitute device according to any preceding claim, wherein the housing includes a
pair of electrode access passages adjacent the airflow inlet, each electrode access passage including an
upstream opening and a downstream opening.
40

12. A smoking substitute device according to claim 11, wherein the blocking element is located upstream of the downstream openings.

5 13. A smoking substitute device according to any preceding claim, wherein the heater is substantially planar.

14. A smoking substitute device according to any preceding claim, wherein the blocking element is substantially planar.

10 15. A smoking substitute device according to claim 13 and claim 14, as dependent on claim 13, wherein a major plane of the planar heater is substantially parallel to a major plane of the blocking element.

15

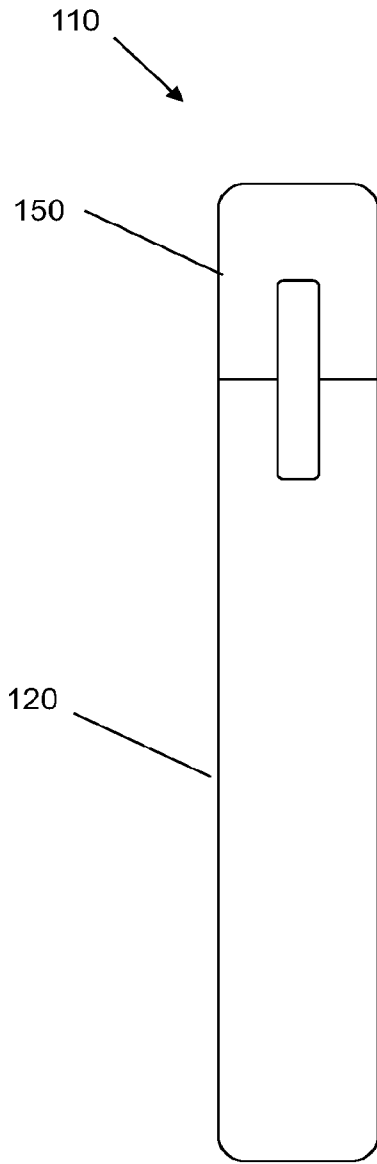

Fig. 1a

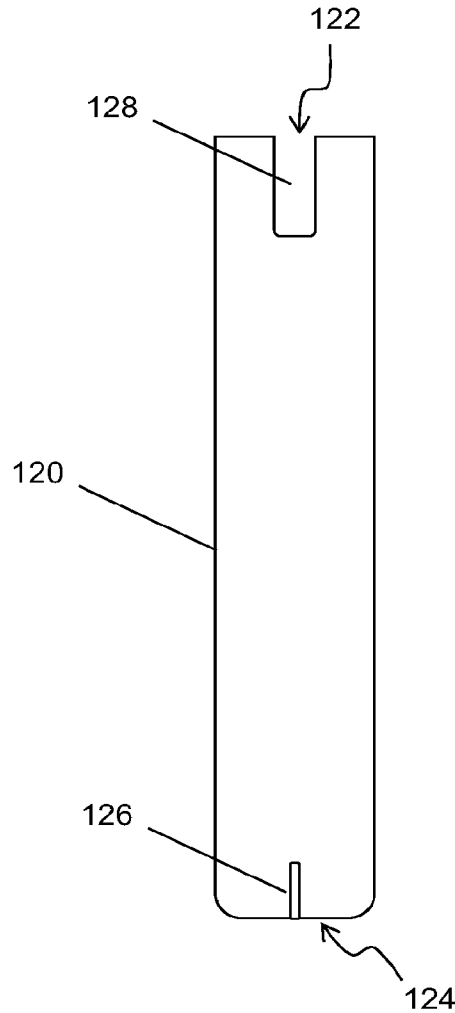

Fig. 1b

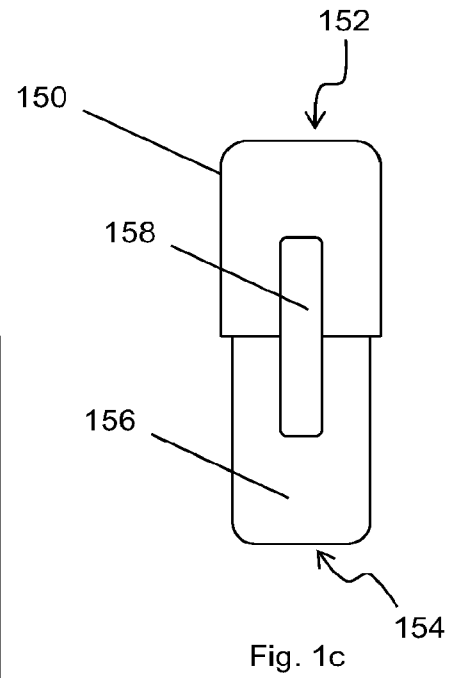

Fig. 1c

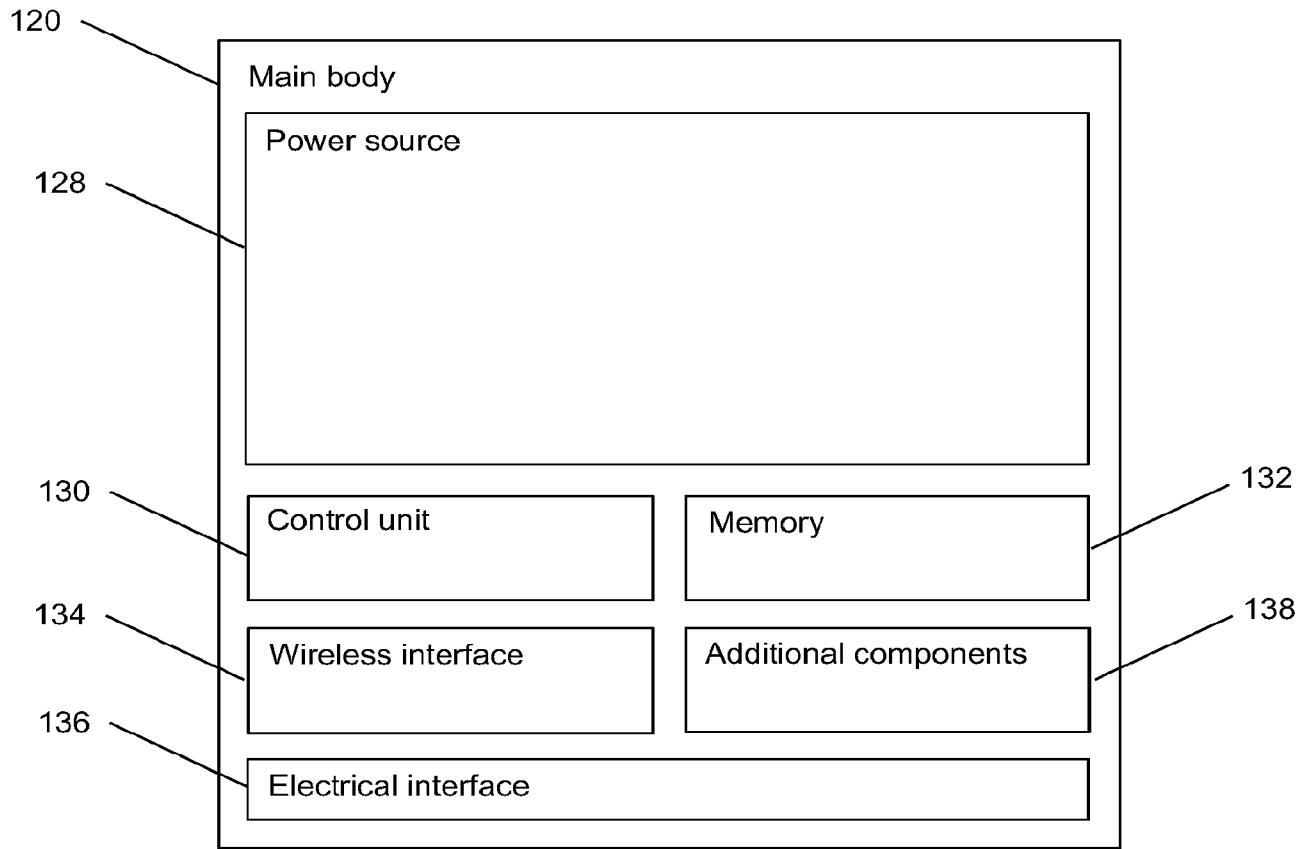

Fig. 2a

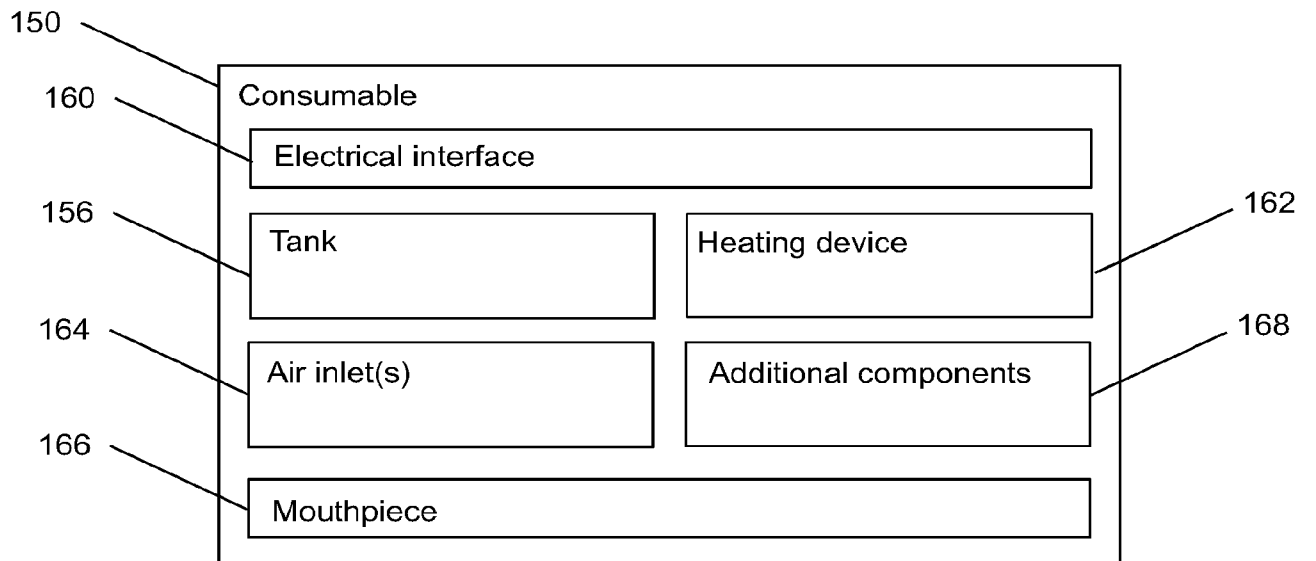

Fig. 2b

3/10

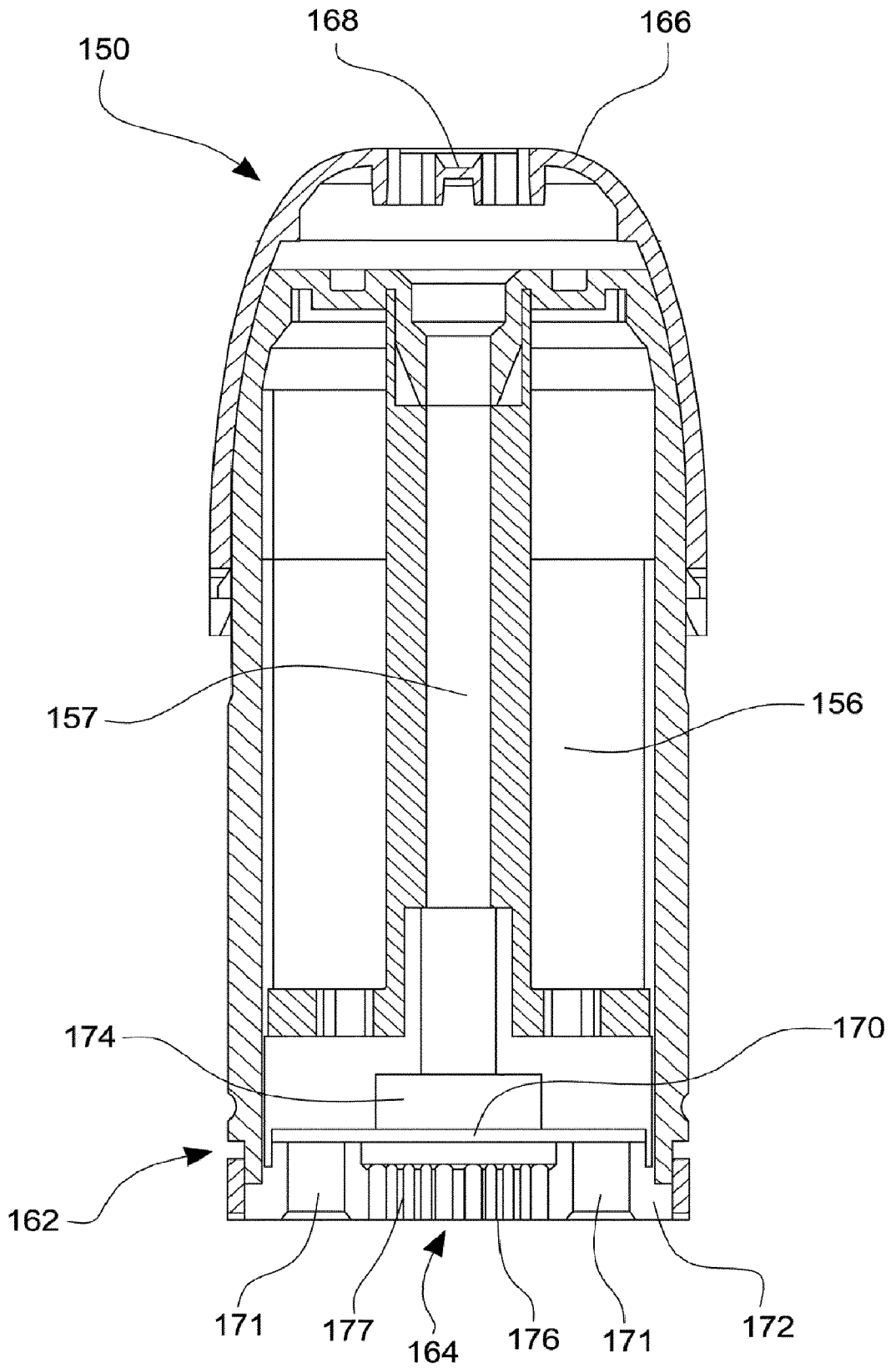

Fig. 3

SUBSTITUTE SHEET (RULE 26)

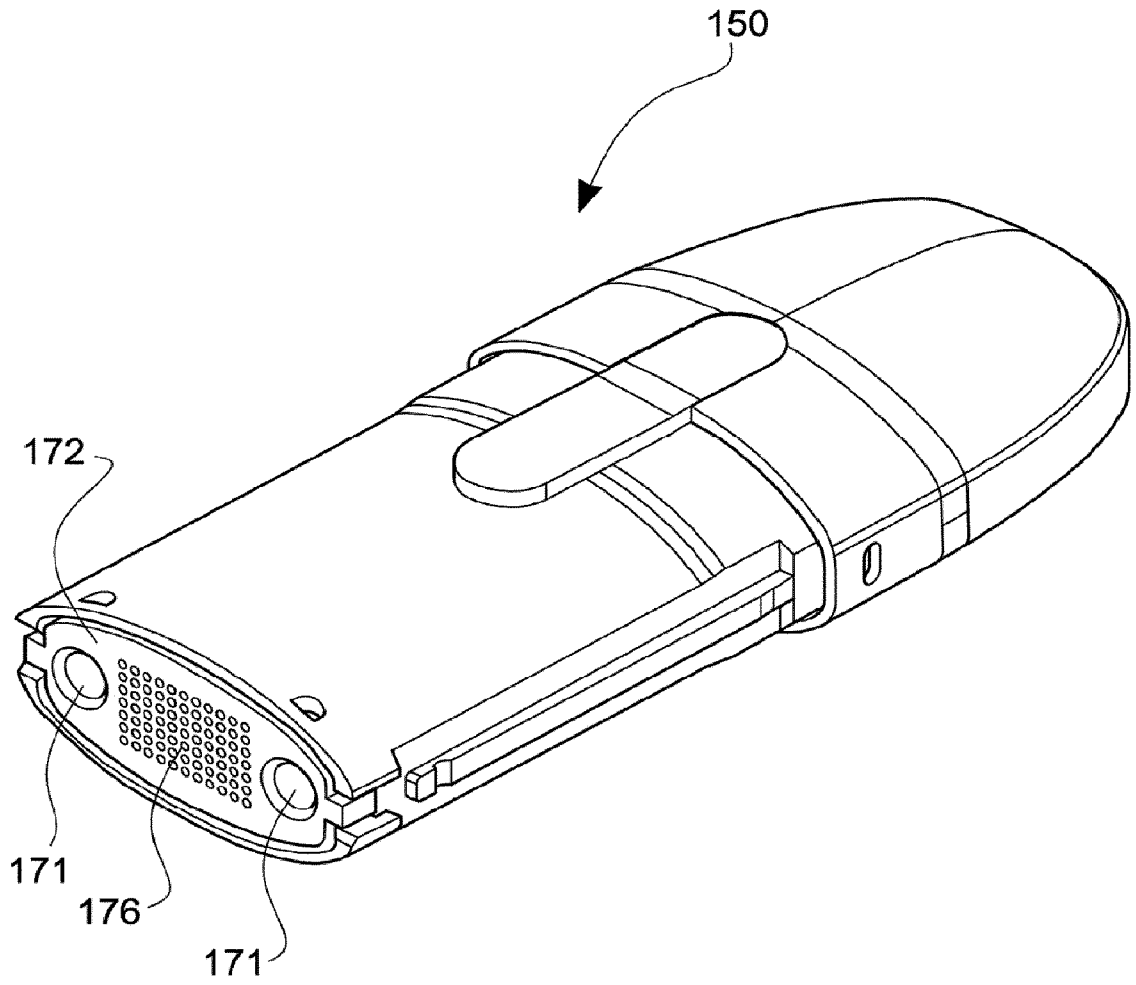

Fig. 4

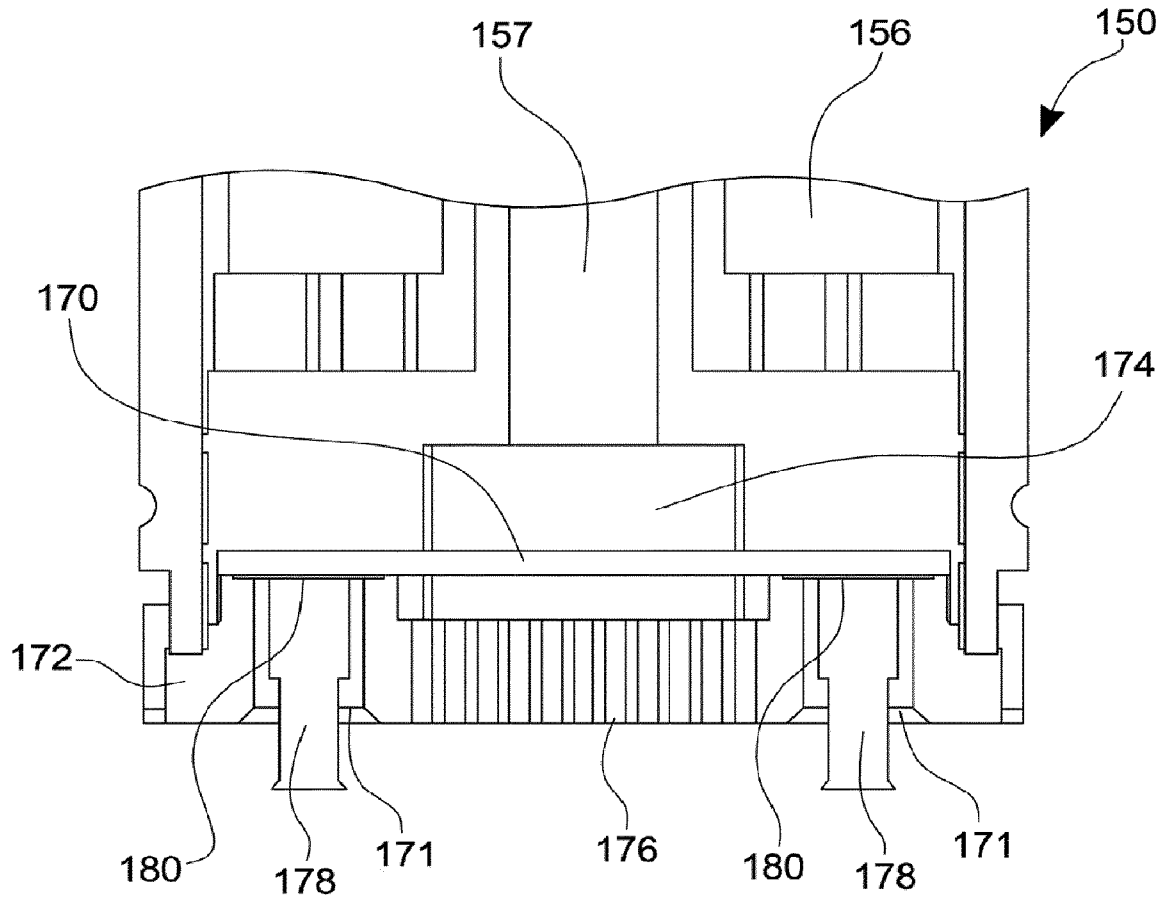

Fig. 5

6/10

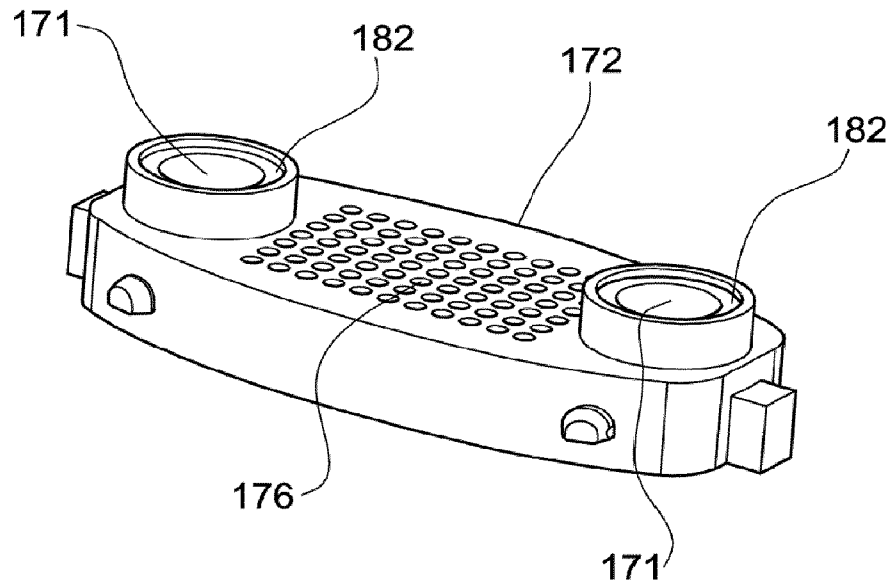

Fig. 6a

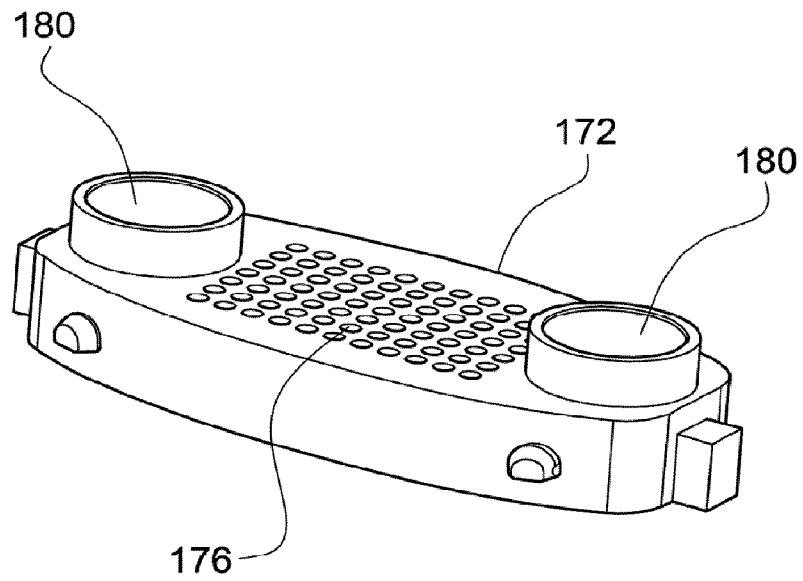

Fig. 6b

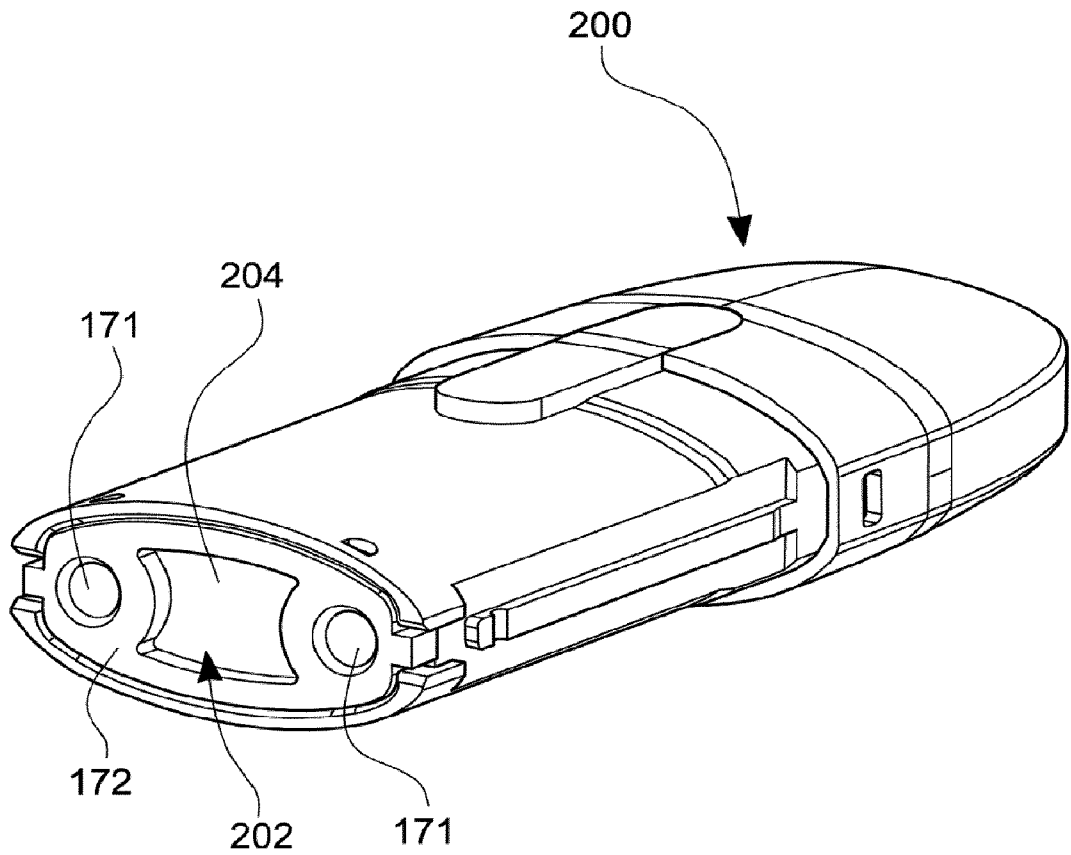

Fig. 7

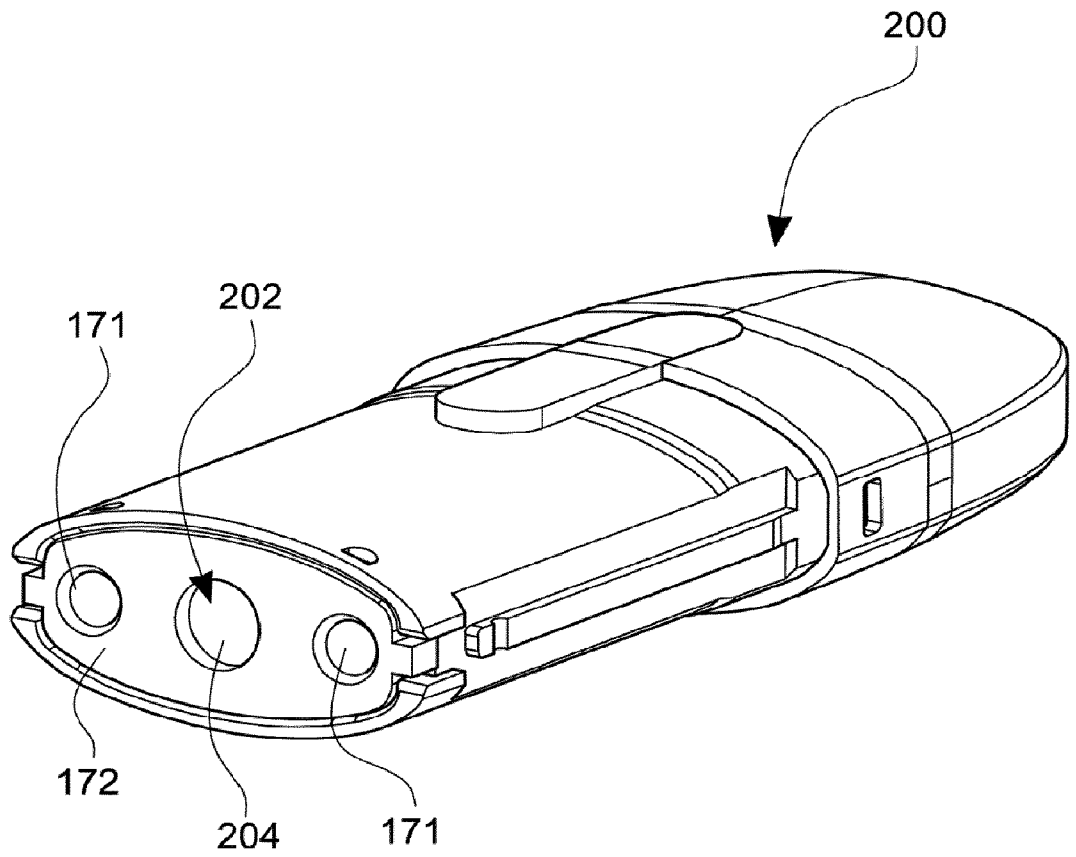

Fig. 8

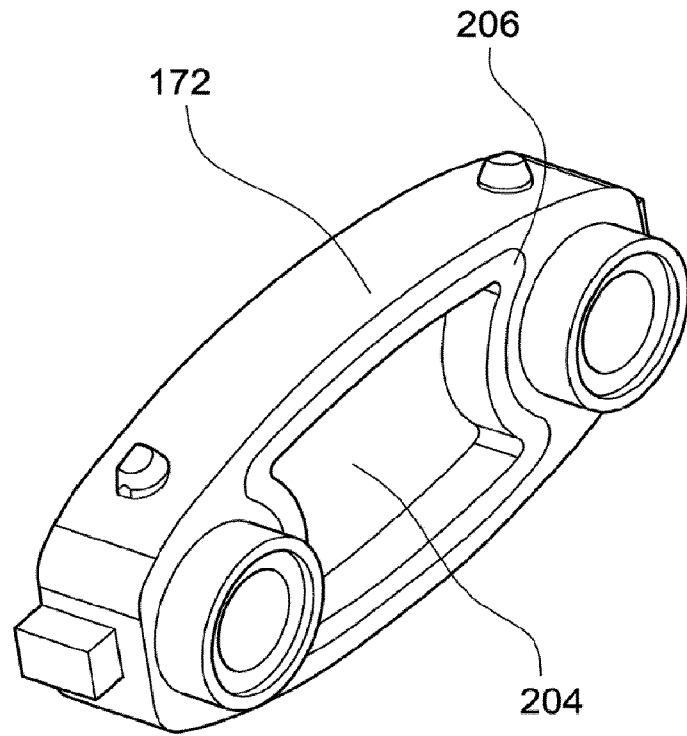

Fig. 9

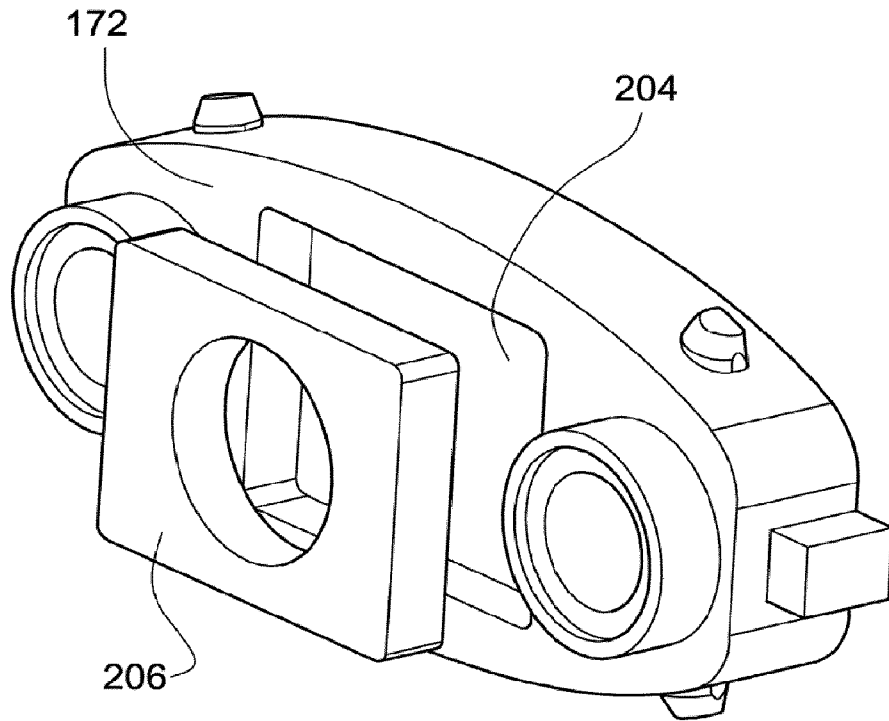

Fig. 10

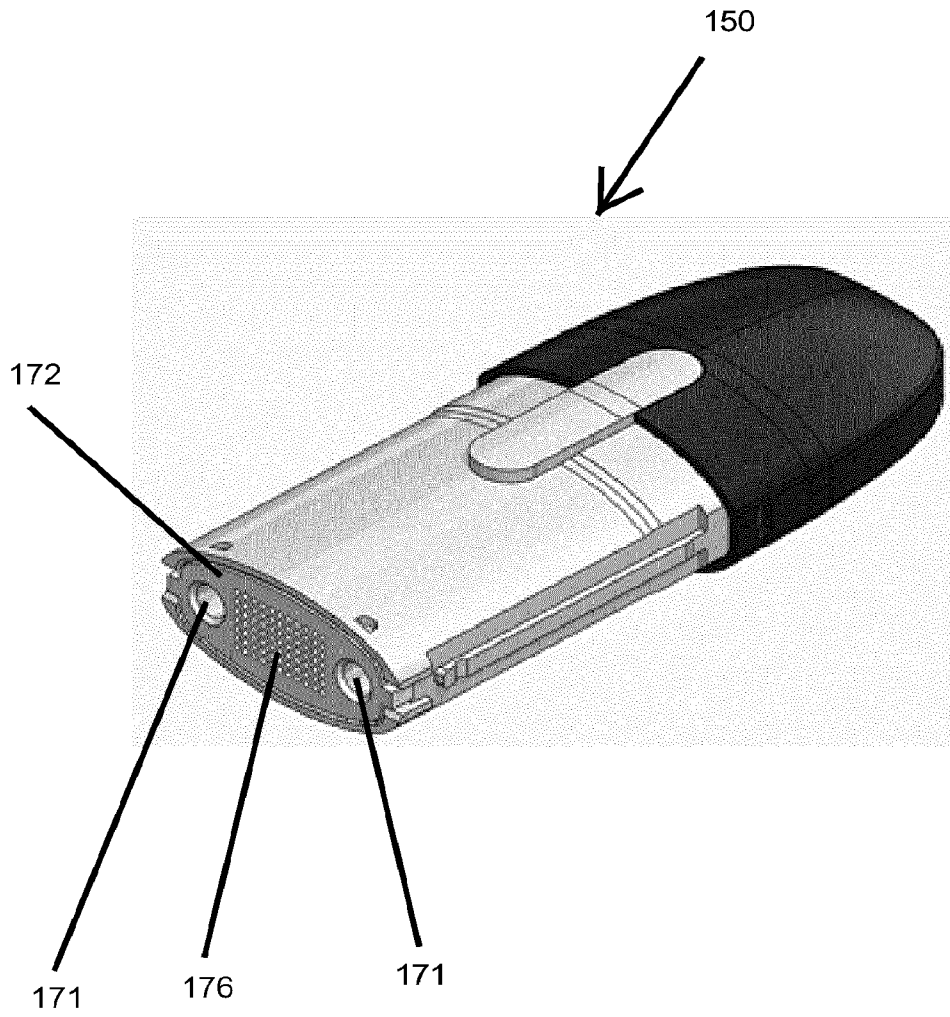

Fig. 4

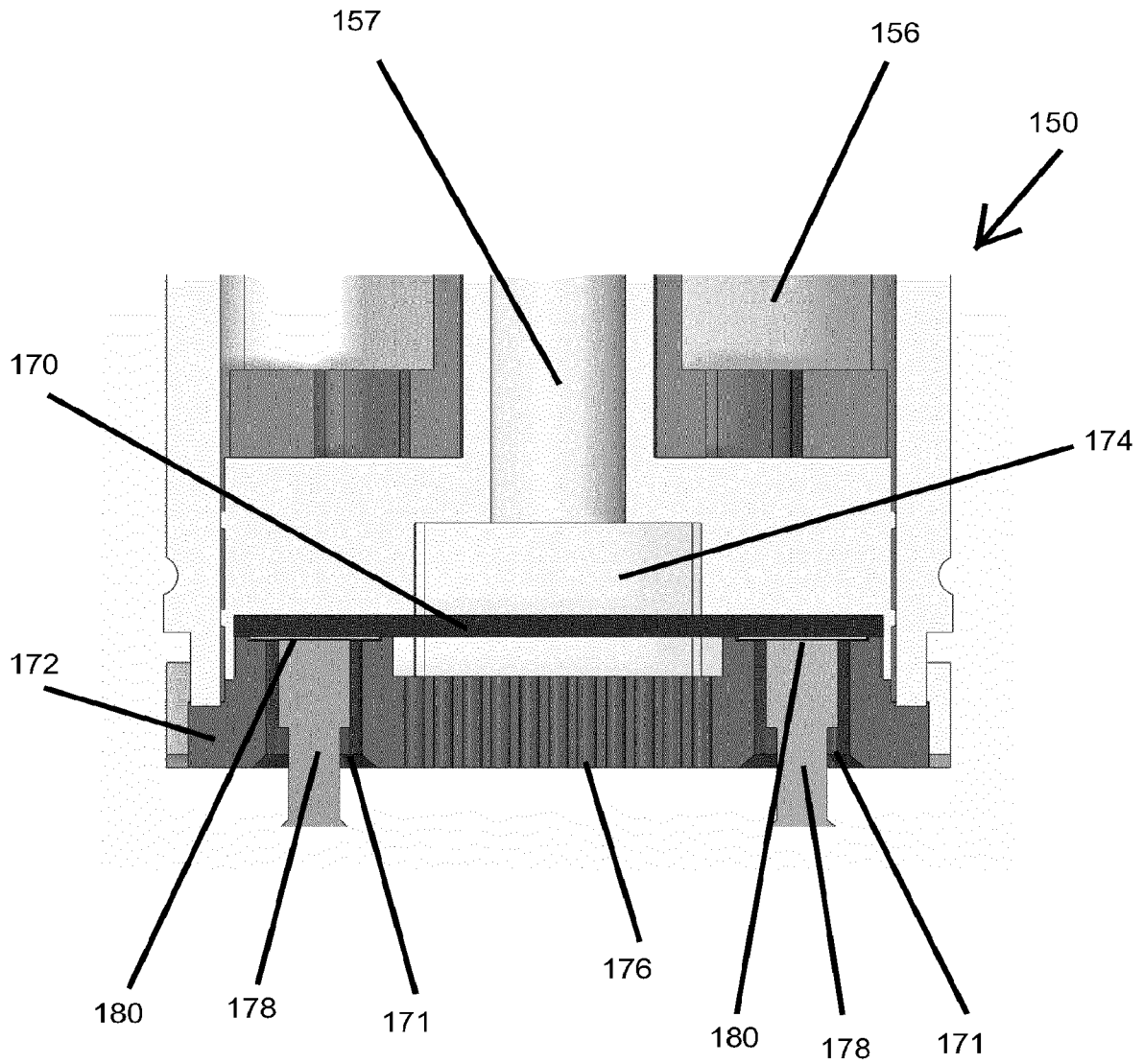

Fig. 5

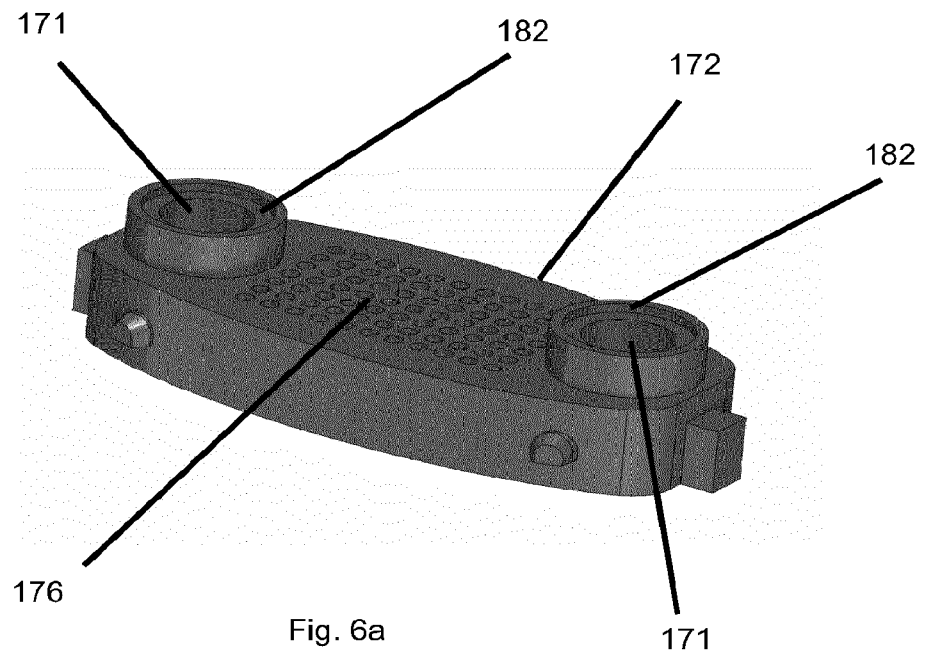

Fig. 6a

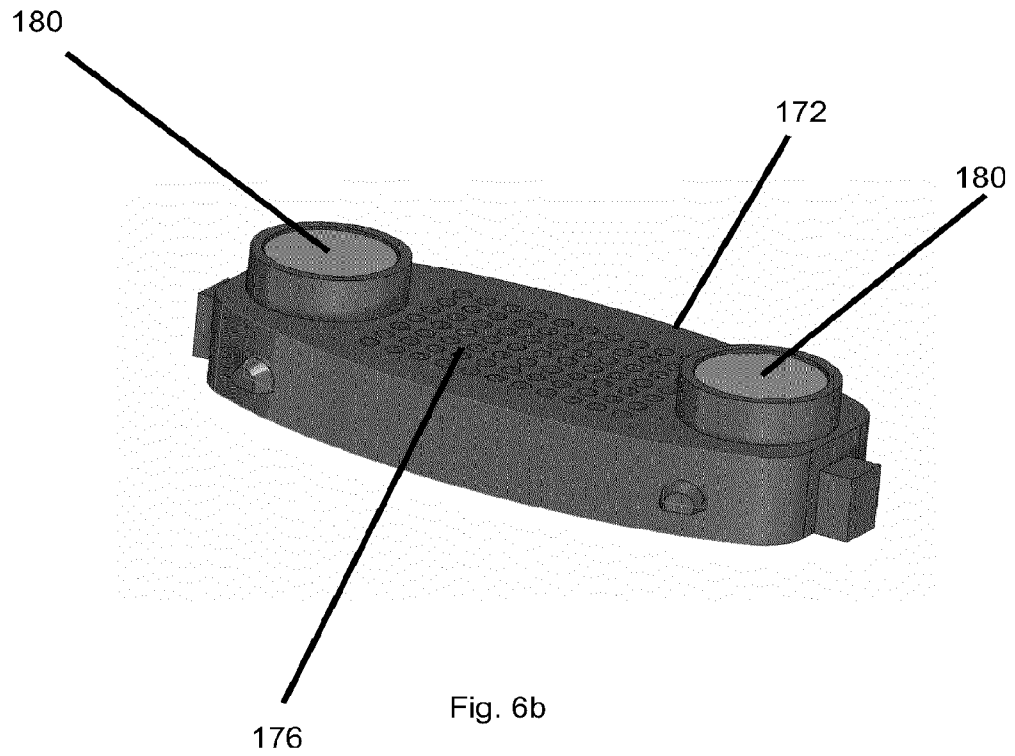

Fig. 6b

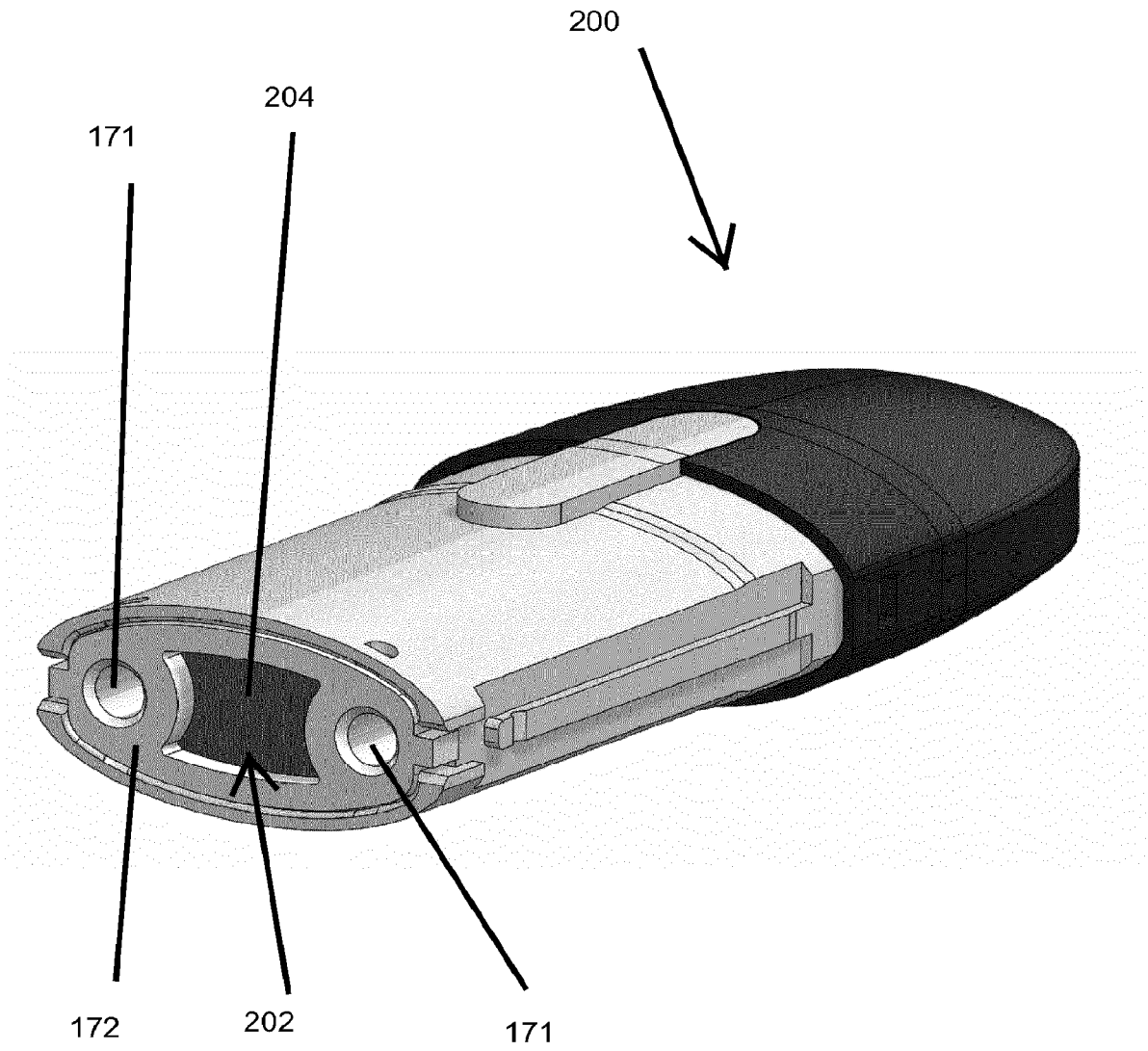

Fig. 7

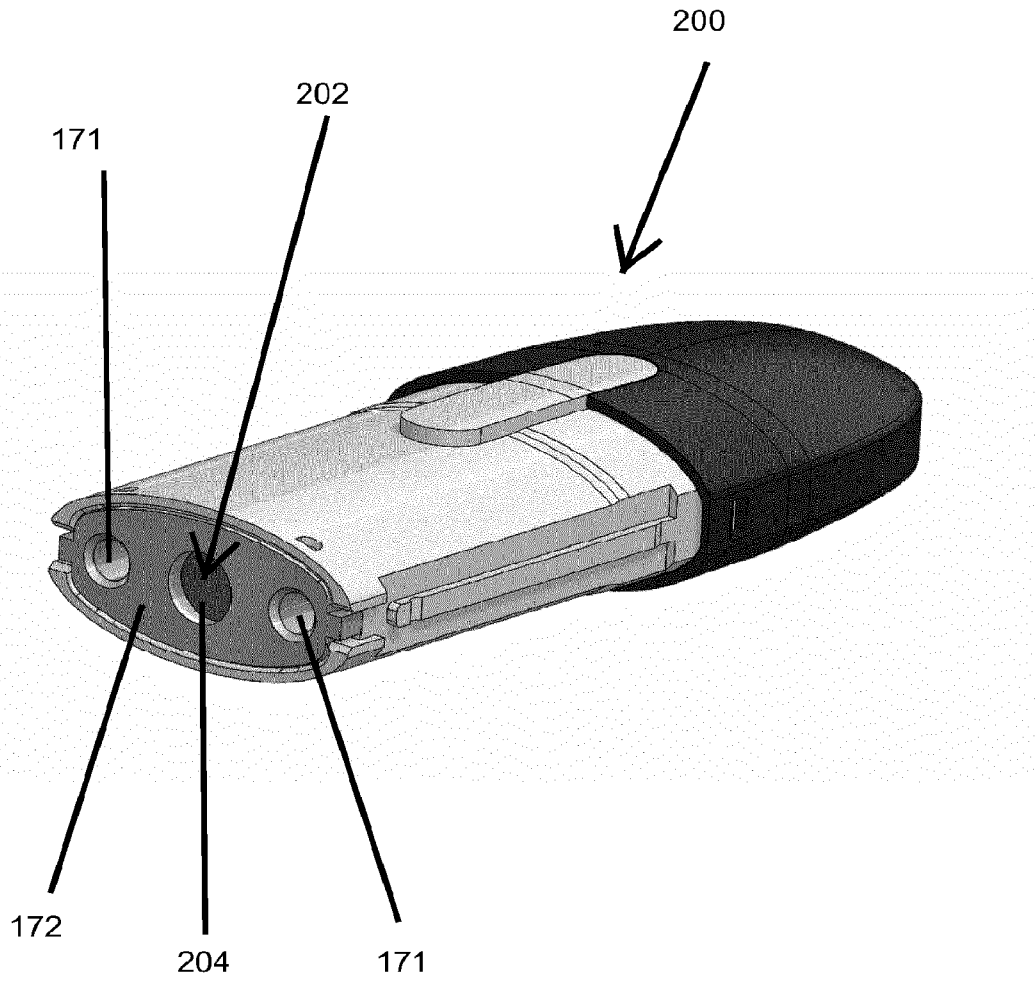

Fig. 8

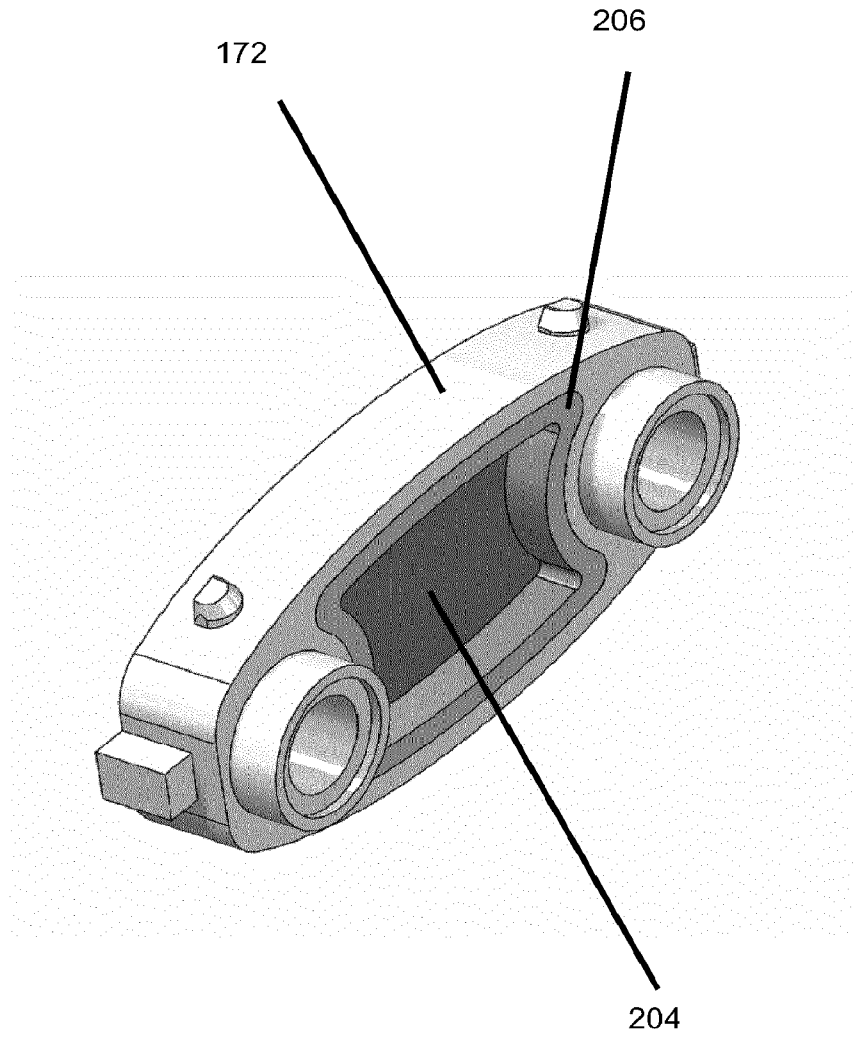

Fig. 9

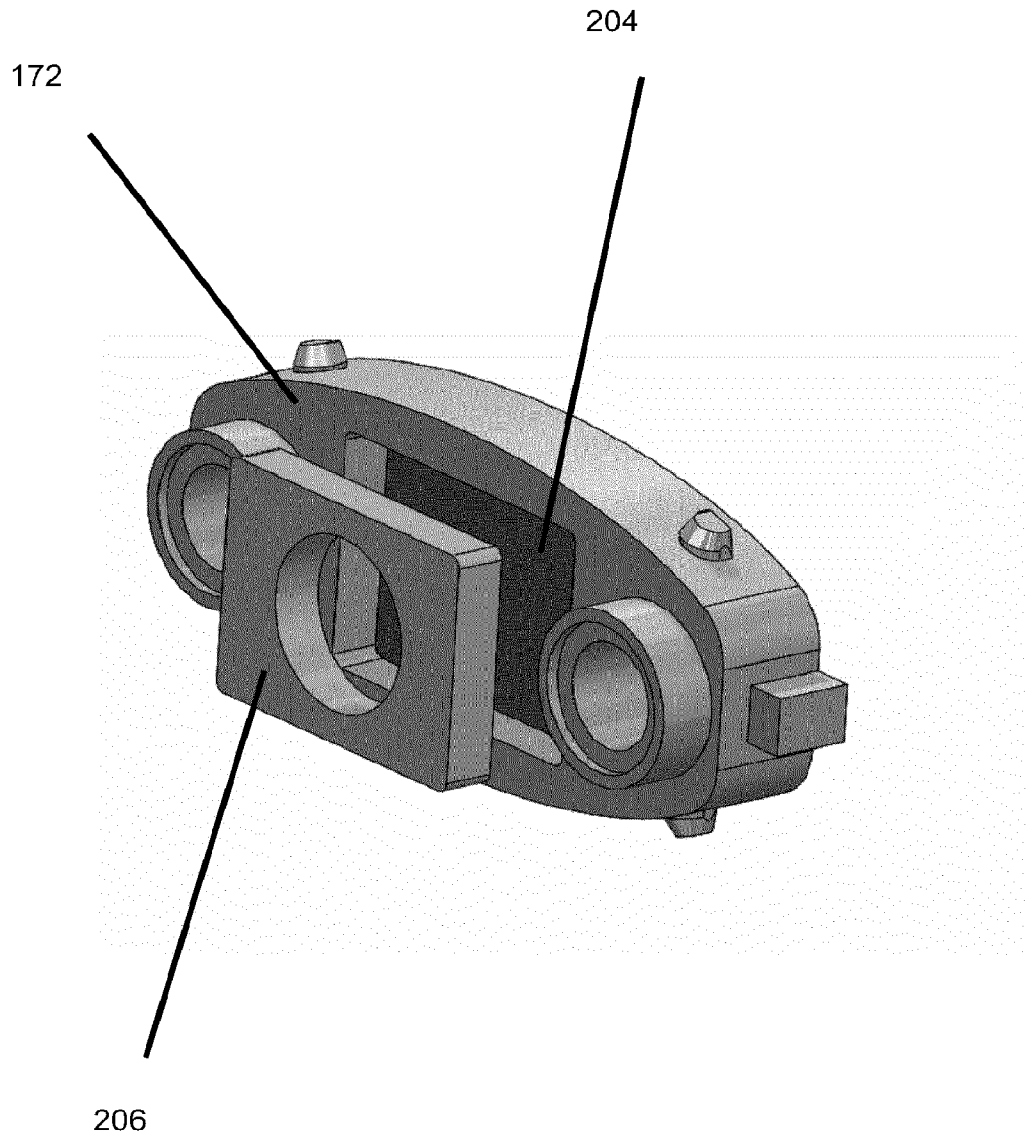

Fig. 10

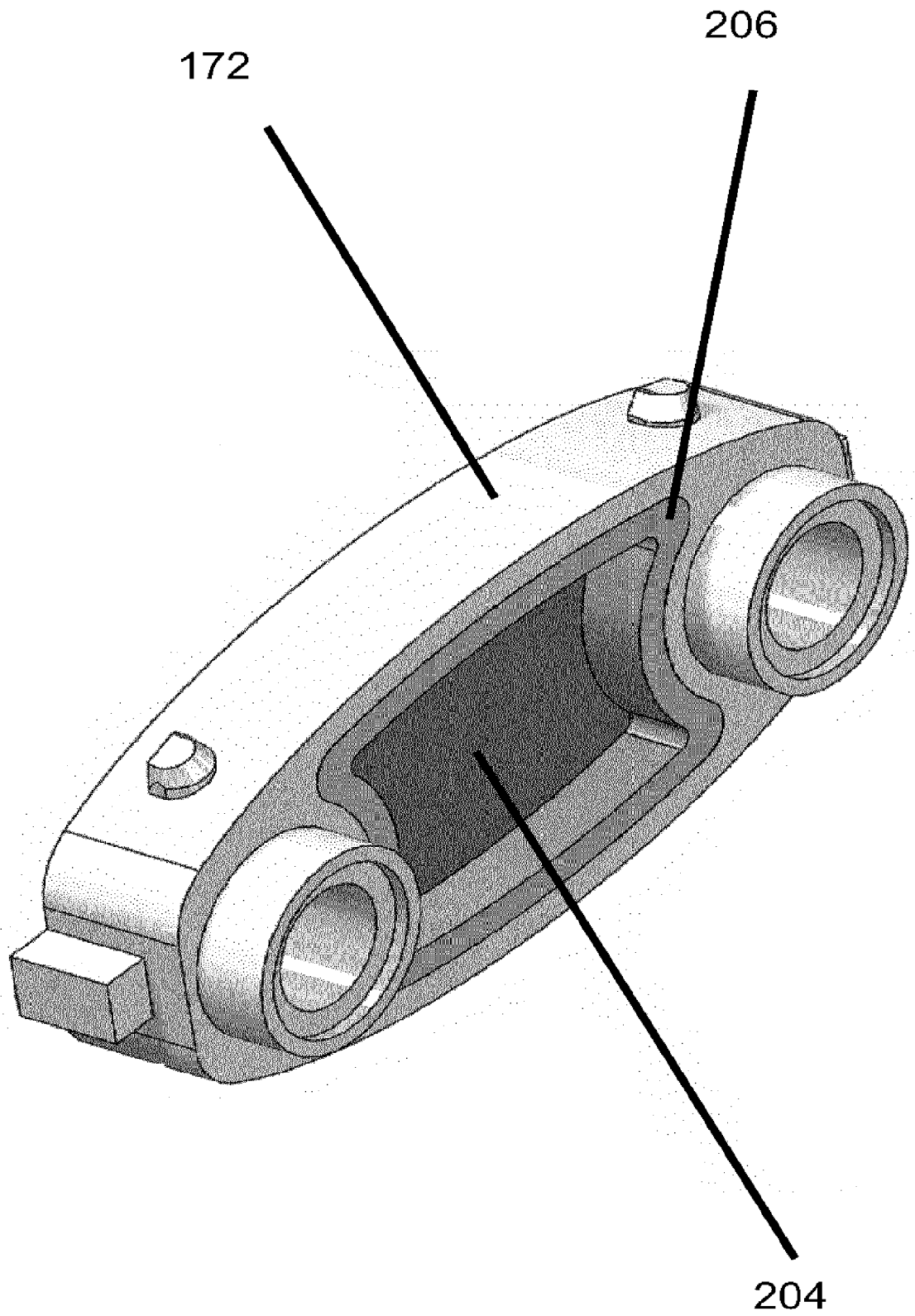

Fig. 9