

J. L. BEERS.  
 QUICK ACTION MONKEY WRENCH.  
 APPLICATION FILED AUG. 19, 1908.

915,540.

Patented Mar. 16, 1909.

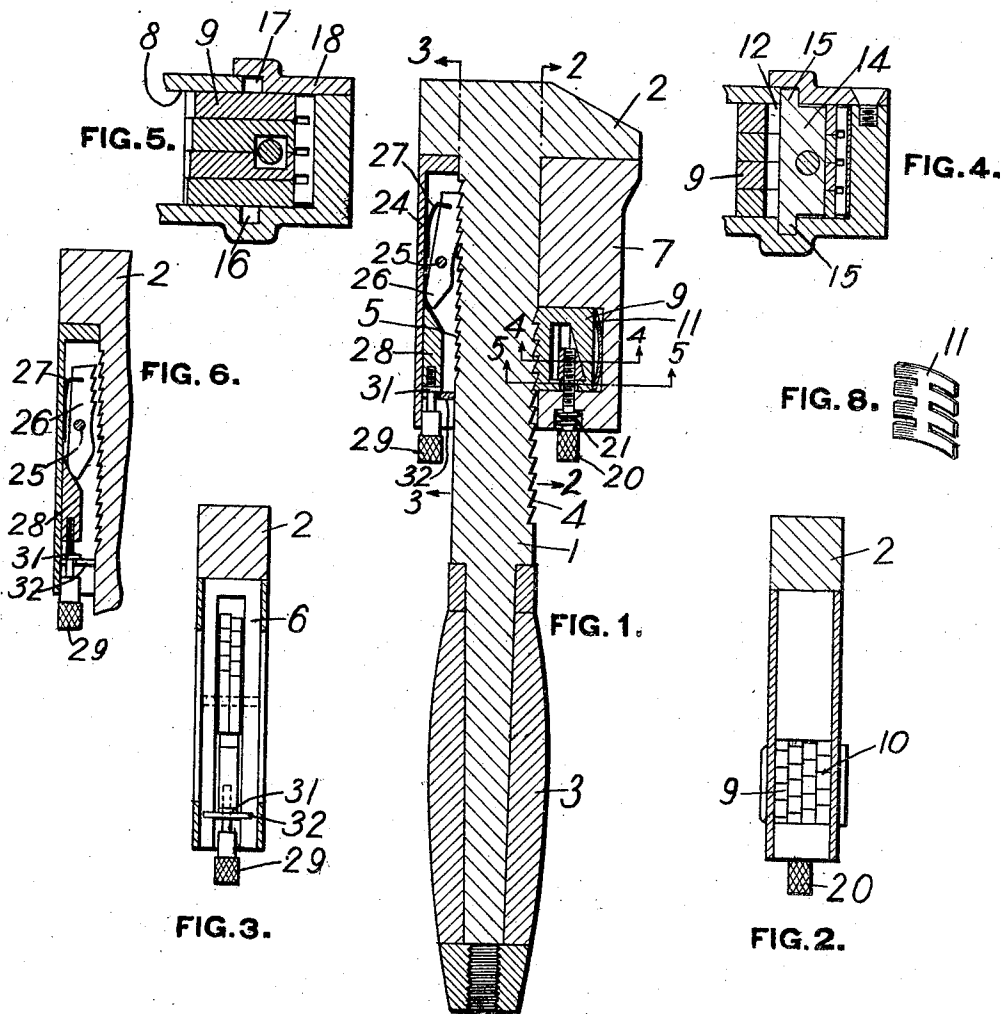

WITNESSES  
*Chas. Footerman*  
*Flora L. Bowersdorf*

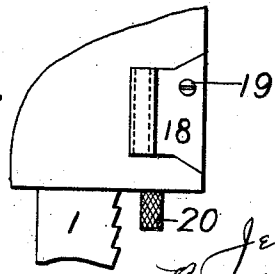

INVENTOR  
*Jeremiah L. Beers*  
 By *Frank H. Whites*  
*His Attorney*

# UNITED STATES PATENT OFFICE.

JEREMIAH L. BEERS, OF WILKINSBURG, PENNSYLVANIA.

## QUICK-ACTION MONKEY-WRENCH.

No. 915,540.

Specification of Letters Patent.

Patented March 16, 1909.

Application filed August 19, 1908. Serial No. 449,324.

To all whom it may concern:

Be it known that I, JEREMIAH L. BEERS, a resident of Wilkinsburg, in the county of Allegheny and State of Pennsylvania, have invented a new and useful Improvement in Quick-Action Monkey-Wrenches, of which the following is a specification.

This invention is a quick-acting monkey-wrench, and the object of the invention is to provide a wrench of this character which is of simple and strong construction, which can be readily operated, which is so constructed as to hold the movable jaw against movement in either direction, and which permits the movable jaw to be moved to engage the nut by means of the hand of the operator which is holding the wrench.

The invention comprises the construction and arrangement of parts hereinafter described and claimed.

In the accompanying drawings Figure 1 is a longitudinal sectional view of a wrench embodying my invention; Fig. 2 is a section on the line 2—2, Fig. 1, showing a face view of the detents on the lower side; Fig. 3 is a similar view on the line 3—3, Fig. 1, showing in face view the detents and operating mechanism on the back of the shank; Fig. 4 is a cross section on the line 4—4, Fig. 1; Fig. 5 is a similar section on the line 5—5, Fig. 1; Fig. 6 is a longitudinal section showing the manner of adjusting the detents on the back of the shank; Fig. 7 is a detail view showing the removable plate covering the wedge block in the lower side of the movable jaw; and Fig. 8 is a perspective view of the spring.

My wrench has the usual shank 1, carrying the fixed jaw 2, and provided with the usual handle 3. The shank is provided with what is usually termed its lower edge with rack teeth 4, which are comparatively coarse, and which preferably run entirely across the lower edge of the shank. On what is usually termed its upper edge or back the shank is also provided with rack teeth 5, which are of only half of the size of the rack teeth 4, and alternate ones of which are located directly opposite the teeth 4. Preferably the rack teeth 5, extend only partly across the back or top of the shank, leaving side portions which are not toothed, to serve as a bearing for the jaw and prevent mutilation of the teeth.

Mounted on the shank is the movable jaw 7, which has a sleeve portion entirely surrounding the shank, as is usual. The bottom portion of the jaw is provided with a re-

cess, 8, open toward the shank and containing a number of detents or dogs 9, in the form of plates provided on their inner edges with teeth 10, cooperating with the teeth 4, on the lower edge of the shank. The teeth on these several detents are arranged in staggered relation with reference to each other, as shown in Fig. 2, so that the jaw can be held in positions constituting fractions of the distance between the teeth 4. Four detents 9, are shown, so that if the rack teeth 4, on the shank are spaced  $\frac{1}{2}$  of an inch, by means of these detents the jaw can be locked at distances of  $\frac{1}{4}$  of an inch apart.

The detent plates 9, are normally held or pressed against the rack teeth by means of a bowed or leaf spring 11, in the recess behind the detents. These detents are provided with openings 12, having one side inclined as shown. In these openings is a wedge block 14, adapted to be moved longitudinally and by acting against the inclined side of the openings, to retract the detents against the action of the spring 11. The wedge block is provided with end portions 15, that at one end working in a groove 16, in one of the walls of the jaw, and the other working in a similar groove 17, in a plate 18, which is removably secured to the jaw, such as by means of a screw 19, so that said plate can be removed to permit the removal of the wedge block to assemble and disassemble the parts. The wedge block 14, is actuated by a pusher or button 20, which projects through a hole in the end of the jaw. This pusher has a threaded connection with the wedge block so that it can be unscrewed and taken out for the purpose of disassembling the parts. It normally is held in its outward position by a spiral spring 21, interposed between a shoulder on said pusher and a ledge surrounding the opening through which the pusher projects.

The back or rear member 24, of the jaw is grooved or recessed longitudinally, and mounted in said groove on a pivot 25, are two detents or dogs 26, adapted to engage the rack teeth 5, on the back of the shank. The teeth of these dogs are also placed in staggered relation with reference to each other. Springs 27, are arranged in the backs of these detents and normally press them into engagement with the rack teeth 5, on the shank. The dogs are disengaged from the rack teeth by a wedge block 28, adapted to be forced behind or beneath the

tails of said dogs. This wedge block is actuated by a pusher 29, projecting through an opening in the end of the jaw. This pusher has a threaded connection with the wedge block and is provided with a collar 31, engaging the plate 32, which is notched to straddle the pusher. This plate and collar serve to prevent longitudinal movement of the pusher when it is rotated, so that by turning the pusher, the threaded connection with the wedge serves to push said wedge underneath the tails of the detents or dogs 26, to hold them in the groove in the jaw or out of contact with the rack teeth, as shown in Fig. 6. This is done only when assembling or disassembling the jaw and shank. For ordinary operations of the wrench the wedge block 28 is actuated by moving the pusher 29 inwardly.

The rack teeth 4 and 5, are oppositely arranged; that is, the teeth 4, face toward the fixed jaw, while the teeth 5, face away from the fixed jaw. Consequently by means of these racks and the detents or dogs described, the movable jaw is held against movement in either direction. The detents 9, and rack teeth 4, hold the movable jaw from opening away from the fixed jaw, but by pushing inwardly on the pusher 20, the detents 9, are released from the rack teeth 4, and the movable jaw can be moved away from the fixed jaw to open the wrench.

The detents 26, and rack teeth 5, hold the movable jaw from accidentally closing, which is important, since after a wrench has been set to fit a certain nut, and it is necessary to remove the same, it is desirable to have the jaw remain in the adjusted position so that frequent applications of the wrench to the nut can be made without further adjustment. By merely pushing in on the pusher 29, however, these detents are disengaged from the rack teeth 5, and the movable jaw can be closed on the nut, or moved toward the fixed jaw. Inasmuch as the pusher 29, projects from the outer end of the movable jaw, it is in a convenient position to be engaged by the thumb of the hand which grasps the handle, so that the wrench can be readily manipulated by a single hand. In other words, it is merely necessary to place the wrench in engagement with the nut, and then by means of the thumb push the pusher 29, and the detents 26, are disengaged from the teeth 5, and simultaneously the movable jaw is pushed up into close contact with the nut. This makes the device very convenient to operate. By turning the pusher 29, the wedge 28, is forced under the tails of the detents 26, thus permanently retracting the same, said wedge being held from moving from underneath the tails of the detents by the collar 31, and plate 32.

The parts are assembled by first placing all of the detents and springs within the recesses in the movable jaw. The wedge block 14, is

put in place through the opening which is closed by the plate 18. The pusher 20, is connected to the wedge block by merely screwing the same into said block. The handle 3, is then removed from the shank, and the shank slipped endwise into the opening in the movable jaw.

To take the wrench apart the handle 3, is removed from the shank, the pusher 29, is rotated to force the wedge 28, underneath the tails of the detents 26, and then by pressing the pusher 20, inwardly and holding the same in that position, the movable jaw can be slipped off the shank. To remove the detent plates 9, from the jaw the plate 18, is removed, the pusher 20, is screwed out of the wedge block, and the wedge block taken out, after which the detent plates 9, can be removed from the inside.

The wrench described is of simple construction, having a small number of simple and strong parts. It positively holds the movable jaw against movement in either direction and can be readily manipulated to close the jaw on the nut by the use of only a single hand.

What I claim is:

1. In a wrench, the combination of a shank provided with two sets of rack teeth, said teeth in the two sets facing in opposite directions, a movable jaw on said shank, two sets of detents carried by said jaw and engaging said racks, each set of detents being provided with teeth staggered relatively to each other, and a pushing element extending through the end of the jaw toward the handle and arranged to release the detents from the rack teeth which face away from the fixed jaw, whereby by merely pushing on said element, the detents are released and the jaw simultaneously moved toward the fixed jaw.
2. In a wrench, the combination of a shank carrying a fixed jaw and provided with rack teeth on its underside facing toward said fixed jaw, a movable jaw on said shank, a series of detents carried by said movable jaw and engaging said rack and provided with teeth staggered relatively to each other, a wedge member arranged to disengage said detents from the rack, and means for moving said wedge member.
3. In a wrench, the combination of a shank carrying a fixed jaw and provided on one edge with rack teeth facing toward said jaw, a movable jaw mounted on said shank, a series of detents carried by said jaw and engaging the rack and provided with teeth staggered relatively to each other, a spring normally pressing said detents into engagement with said rack, a wedge block engaging said detents, means for actuating said wedge block, and a removable plate arranged to permit the removal of said wedge block.
4. In a wrench, the combination of a shank carrying a fixed jaw and provided on one

edge with rack teeth facing toward the fixed jaw, a movable jaw on said shank, detents carried by said movable jaw and provided with openings therethrough, a spring normally pressing said detents into engagement with the rack teeth, a wedge block located in the openings of said detents and arranged to actuate the same, an actuating member having a disconnectible connection with said wedge block, and a removable plate closing an opening through which the wedge block can be withdrawn.

5. In a wrench, the combination of a shank provided with rack teeth, a jaw movably mounted on said shank, detents pivotally mounted on said jaw and engaging said rack teeth, springs normally holding said detents in engagement with said rack teeth, a wedge slidably mounted in the jaw and engaging the tails of said pivoted detents, and a pushing member for actuating said wedge.

6. In a wrench, the combination of a shank provided with rack teeth, a movable jaw on said shank, detents mounted on said jaw, a wedge arranged to move said detents out of engagement from the rack teeth, a pusher having a threaded engagement with said wedge and mounted to rotate and also recip-

rocate inwardly and move the wedge, and means for holding said pusher against outward movement when rotated, whereby the wedge is forced into position to hold the detents permanently out of engagement with the rack teeth.

7. In a wrench, the combination of a shank provided with a fixed jaw and with rack teeth on opposite faces and facing in opposite directions, a movable jaw on a shank, detents carried by said movable jaw and engaging said rack teeth and arranged to hold the movable jaw from movement both toward and from the fixed jaw, and a reciprocating actuating member for the detent engaging the teeth facing away from the fixed jaw, said actuating member projecting from the outer end of the jaw toward the handle, whereby when said member is pushed the detent is released from the rack teeth and the movable jaw simultaneously moved toward the fixed jaw.

In testimony whereof, I have hereunto set my hand.

JEREMIAH L. BEERS.

Witnesses:

G. GLEN CAIN,  
JOHN J. WALKER.