



- (51) **International Patent Classification:**
H05B 6/64 (2006.01) *A47J 43/07* (2006.01)
- (21) **International Application Number:**
PCT/EP2019/067731
- (22) **International Filing Date:**
02 July 2019 (02.07.2019)
- (25) **Filing Language:** English
- (26) **Publication Language:** English
- (30) **Priority Data:**
2021239 04 July 2018 (04.07.2018) NL
- (71) **Applicant:** **EGGCITING PRODUCTS B.V.** [NL/NL];
Onderwijsboulevard 225, 5223 DE 's-Hertogenbosch (NL).
- (72) **Inventors:** **HIJMA, Herman**; Kampen (NL). **SLURINK, Oscar**; Heino (NL). **GIEZEMAN, Dennis**; Den Haag (NL). **KASBERGEN, Michael**; Schoonhoven (NL). **BIVERT, Marcel Alexander**; Maastricht (NL).
- (74) **Agent:** **VELDMAN-DIJKERS, Cornelia Geerdina Catherina**; AB Ovo Patents B.V., Platz 1 -Limbricht, 6141AT Sittard-Geleen (NL).
- (81) **Designated States** (*unless otherwise indicated, for every kind of national protection available*): AE, AG, AL, AM, AO, AT, AU, AZ, BA, BB, BG, BH, BN, BR, BW, BY, BZ,

CA, CH, CL, CN, CO, CR, CU, CZ, DE, DJ, DK, DM, DO, DZ, EC, EE, EG, ES, FI, GB, GD, GE, GH, GM, GT, HN, HR, HU, ID, IL, IN, IR, IS, JO, JP, KE, KG, KH, KN, KP, KR, KW, KZ, LA, LC, LK, LR, LS, LU, LY, MA, MD, ME, MG, MK, MN, MW, MX, MY, MZ, NA, NG, NI, NO, NZ, OM, PA, PE, PG, PH, PL, PT, QA, RO, RS, RU, RW, SA, SC, SD, SE, SG, SK, SL, SM, ST, SV, SY, TH, TJ, TM, TN, TR, TT, TZ, UA, UG, US, UZ, VC, VN, ZA, ZM, ZW.

- (84) **Designated States** (*unless otherwise indicated, for every kind of regional protection available*): ARIPO (BW, GH, GM, KE, LR, LS, MW, MZ, NA, RW, SD, SL, ST, SZ, TZ, UG, ZM, ZW), Eurasian (AM, AZ, BY, KG, KZ, RU, TJ, TM), European (AL, AT, BE, BG, CH, CY, CZ, DE, DK, EE, ES, FI, FR, GB, GR, HR, HU, IE, IS, IT, LT, LU, LV, MC, MK, MT, NL, NO, PL, PT, RO, RS, SE, SI, SK, SM, TR), OAPI (BF, BJ, CF, CG, CI, CM, GA, GN, GQ, GW, KM, ML, MR, NE, SN, TD, TG).

Published:

— *with international search report (Art. 21(3))*

- (54) **Title:** AN OVEN, AS WELL AS A METHOD FOR STIRRING FOODSTUFF CONTAINED IN A VESSEL DISPOSED IN THE COOKING CAVITY OF SUCH AN OVEN AND A STIRRER MEMBER FOR SUCH AN OVEN

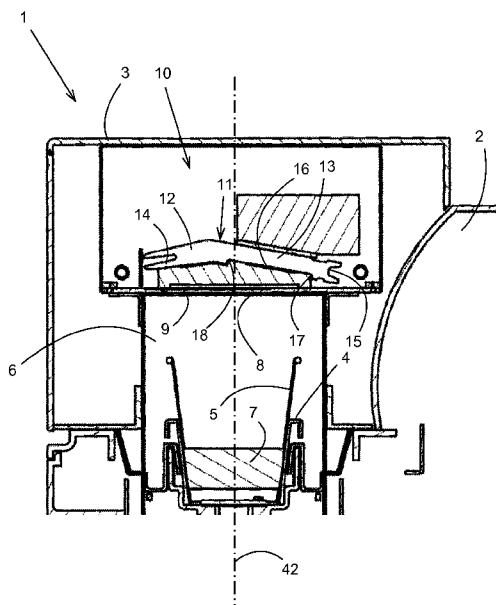

Fig. 2A

- (57) **Abstract:** An oven comprises a cooking cavity, a stirring member extending, in use, into foodstuff contained in a vessel disposed in the cooking cavity as well as drive means to provide, in use, relative movement between the stirring member and the vessel. The oven comprises a displacement device to move the stirring member from outside the cooking cavity through an opening in a wall bounding the cooking cavity into the cooking cavity as well as, in use, into the vessel disposed in the cooking cavity.



An oven, as well as a method for stirring foodstuff contained in a vessel disposed in the cooking cavity of such an oven and a stirrer member for such an oven

FIELD OF THE INVENTION

5

The invention relates to an oven comprising a cooking cavity, a stirring member extending, in use, into foodstuff contained in a vessel disposed in the cooking cavity as well as drive means to provide, in use, relative movement between the stirring member and the vessel.

10

The invention also relates to a method for stirring foodstuff contained in a vessel disposed in the cooking cavity of an oven by means of a stirring member, whereby the vessel is relatively moved with respect to the stirring member.

The method further relates to a stirrer member for such an oven.

15 BACKGROUND OF THE INVENTION

By a microwave oven and method as known from GB2159027, the microwave oven cavity is provided with a conventional vertical rotational drive shaft for rotating a bowl. The bowl has a lid, which supports a stirring paddle. During use, 20 gears and gearing track around the rim of bowl cause relative rotational movement between the bowl and paddle, which effects agitation of any foodstuff, such as soups, sauces, etc., in the bowl, whilst the foodstuff is being cooked by microwave energy emitted into the cavity, as well as during periods when the foodstuff is not being cooked.

25

By this microwave oven a lid is needed to support the stirring paddle and this lid must be placed on top of the bowl before the bowl can be placed in the microwave oven cavity. After preparing the foodstuff, the lid and the stirring paddle needs to be cleaned before it can be used again. Furthermore, rotation of the paddle depends on the rotation of the bowl.

30

SUMMARY OF THE INVENTION

At least one of the objects of the invention is to provide an oven whereby the placement of the stirring member in the vessel by a user is been simplified.

5 This object is accomplished with the oven according to the invention in that the oven comprises a displacement device to move the stirring member from outside the cooking cavity through an opening in a wall bounding the cooking cavity into the cooking cavity as well as, in use, into the vessel disposed in the cooking cavity.

10 An oven according to this patent application is every device by means of which the foodstuff can be heated. The vessel can be located inside the cooking cavity of the oven.

With such a displacement device, a user only needs to place the stirring member in the displacement device, after which the displacement device will automatically move the stirring member through an opening in a wall bounding the cooking cavity into the vessel disposed in the cooking cavity.

20 During or after cooking, the stirrer member can be used as cutlery. The displacement device can be used in combination with a number of different kinds of vessels. Since the stirring member is being moved from outside the cooking cavity into the vessel disposed in the cooking cavity, less material is needed inside the cooking cavity to achieve stirring and less energy will be absorbed by material other than the foodstuff in the vessel. Furthermore, this provides the possibility to move the stirrer member independent from a rotation of the vessel about a vertical axis. This could give options in optimizing a cooking program, for example letting depend the rotational speeds from the temperature of the foodstuff.

30 An embodiment of the oven according to the invention is characterized in that the oven comprises a holder for holding a number of stirring members, wherein the displacement device is provided with a separating device to separate one of the stirring members from the number of stirring members located in said holder and to move said first one of the number of stirring members from outside

the cooking cavity through the wall bounding the cooking cavity into the cooking cavity as well as, in use, into the vessel disposed in the cooking cavity.

With such a holder an operator will place the number of stirring members in the holder, after which a user only needs to place the foodstuff in the vessel or a vessel comprising the foodstuff in the cooking cavity, after which the one stirring member will be automatically positioned in the vessel by the displacement device. After preparing the foodstuff, the vessel with the prepared foodstuff as well as the stirring member can be removed from the cooking cavity, so that subsequently a next vessel with foodstuff can be inserted into the cooking cavity. Depending on the shape of the stirring member, the stirring member can be used as an eating utensil, like a fork, spoon, spork, skewer. The stirring member can be disposable or reusable.

Another embodiment of the oven according to the invention is characterized in that the number of stirring members are stacked upon each other in the holder in a stacking direction, which displacement device comprises a transport device to transport the stacked number of stirring members in the stacking direction, which separating device comprises a pivoting device to pivot a first one of the stacked number of stirring members about a pivot axis extending parallel to the stacking direction through the opening in the wall.

Stacking of the stirring members ensures that a relative large number of stirring members can be compactly and easily stored. Furthermore, movement of the stacked number of stirring members can easily be done in the stacking direction without the risk that the stack gets distorted. By pivoting the first one of the stacked number of stirring members about a pivot axis extending parallel to the stacking direction, said stirring member is being separated from the rest of the stack and can be moved through the opening in the wall.

Such pivoting is especially simple in case that the stirring members are plate shaped, wherein the number of stirring members are stacked upon each other in the holder with plate-shaped surfaces of adjacent stirring members being in abutment with each other.

Another embodiment of the oven according to the invention is characterized in that the displacement device comprises a translation device to translate the pivoted stirring member in a translation direction extending perpendicular to the pivot axis towards the vessel.

5 By means of such translation device it is possible to pivot the stirring member about a pivot axis located close to an end of the stirring member and close to the opening in the wall, whereas as the end of the stirring member has been moved through the opening in the wall, the stirring member can be moved in the translation direction extending perpendicular to the pivot axis towards the vessel.

10 In this manner, the opening in the wall can be relatively small. This has the advantage that no or relatively simple additional manners need to be taken to avoid that microwaves will go through the opening to the outside of the microwave oven, in case the oven is a microwave oven. Also in case that the oven is a steam oven, the relative small opening in the wall has the advantage that no or relatively

15 simple additional manners need to be taken to avoid that steam will go through the opening to the outside of the steam oven.

Another embodiment of the oven according to the invention is characterized in that the stirring member is translated under spring force in the translation direction.

20 In such a manner, the stirring member can easily be translated.

Another embodiment of the microwave oven according to the invention is characterized in that the displacement device comprises a releasing device to release the stirring member from the displacement device.

In this manner, the stirring member will be held by the displacement device

25 in the vessel, until the stirring member is being released by the releasing device. The releasing device can be actuated for example as soon as the cooking of the foodstuff has been finished and no more relative movement between the vessel and stirring member is needed.

Another embodiment of the oven according to the invention is characterized

30 in that the drive means comprises means to rotate, in use, the vessel with respect

to the stirring member about a rotating axis, whilst the displacement device comprises means to swivel the stirring member about a swivel axis extending at an angle of between 60-120 degrees, preferably substantially perpendicular to the rotating axis.

5 Rotating of the vessel ensures that a more uniform heating of the foodstuff in the vessel occurs by preventing the formation of hotspots. The foodstuff is mixed inside the vessel by means of the stirrer member, which further prevents the formation of hotspots. In case that the foodstuff for example changes from liquid to a more solid state like by scrambled eggs, the stirrer member also causes a
10 mixing of the more liquid foodstuff and more solidified foodstuff. Although it is preferred that the swivel axis extends perpendicular to the rotating axis in view of the simplicity of the design, an angle between 60-120 degrees is also possible to still have a swivelling movement in addition to a rotational movement.

By also swivelling the stirrer member with respect to the vessel and the
15 foodstuff located therein, the foodstuff is being further mixed. By moving the stirrer member with respect to the foodstuff, it is also prevented that the foodstuff will get attached to the stirrer member and will be moved together with the stirrer mechanism with respect to the vessel. Due to the swivelling movement, the foodstuff is being cut. This is especially interesting by preparing scrambled eggs. So
20 far it was not possible to prepare scrambled eggs in an oven since by no prior art oven a stirrer member can be rotated as well as stirred with respect to the vessel, which kind of motion provides the cooked egg with scrambled egg appearance with pieces of cooked egg. The foodstuff may also comprise an egg mixture, which foodstuff after cooking has a scrambled egg appearance with pieces of cooked egg
25 mixture. Sticking of the foodstuff to the stirrer member depends amongst others on the kind of foodstuff, the material and smoothness of the stirrer member, the rotational speed of the vessel, the swivelling speed of the stirrer member, the shape of the stirrer member and the displacement of the stirrer member.

Another embodiment of the oven according to the invention is characterized
30 in that the oven is a microwave oven, a steam oven or another kind of oven.

By means of microwaves or steam foodstuff can easily be heated at a desired speed to a desired temperature.

The invention also relates to a method for stirring foodstuff contained in a vessel disposed in the cooking cavity of an oven by means of a stirring member, whereby the vessel is relatively moved with respect to the stirring member, which method is characterized in that by means of a displacement device the stirring member is being moved from outside the cooking cavity through an opening in a wall bounding the cooking cavity into the cooking cavity and into the vessel disposed in the cooking cavity.

With such a method, a stirring member can easily be inserted into the vessel.

BRIEF DESCRIPTION OF THE DRAWINGS

The oven and method according to the invention will further be explained with reference to the drawings, wherein,

figure 1A and 1B are perspective views of a microwave oven according to the invention, whereby in figure 1A the microwave oven is being closed and in figure 1B the microwave oven is being opened,

figure 2A-2C are detailed cross sections of the microwave oven as shown in figure 1A, in respectively a position wherein the stirring member is located outside the cooking cavity, is located inside the vessel in a first position and is located inside the vessel in a second position,

figure 3 is a perspective view of a first embodiment of a displacement device of the microwave oven as shown in figure 1A and 1B,

figures 4A-4M are detailed side views of the displacement device as shown in figure 3 in several different positions during the insertion of the stirring member into the vessel,

figures 5 and 6 are perspective views of a second embodiment of a displacement device of the microwave oven as shown in figure 1A and 1B,

figures 7 and 8 are perspective views of a third embodiment of a displacement device of the microwave oven as shown in figure 1A and 1B,

figures 9-12 10 are perspective views of a fourth embodiment of a displacement device of the microwave oven as shown in figure 1A and 1B.

5 In the drawings, like reference numerals refer to like elements.

DESCRIPTION OF PREFERRED EMBODIMENTS

10 Figures 1A and 1B show perspective views of a microwave oven 1 according to the invention. The microwave oven 1 comprises a lower part 2 and an upper part 3 which can be pivoted in a direction as indicated by arrow P1 from a closed position as shown in figure 1A to an open position as shown in figure 1B.

The lower part 2 comprises a holder 4 in which a vessel 5 like a cup can be removable placed in the open position of the microwave oven 1.

15 In the vessel 5 foodstuff to be prepared in the microwave oven 1 can be inserted. The foodstuff can be a liquid like soup or sauce or a mixture to prepare a scrambled egg comprising egg or only egg white and if desired milk, mushrooms, tomatoes, unions bacon, chicken, banana, cream, yoghurt, salmon, herbs of any kind (pepper, salt, oregano), leek, capers, cheese etc. The foodstuff can also be a mixture for a shredded pancake like Kaiserschmarrn, noodles or a muffin.

20 Figure 2A is a detailed cross sections of the microwave oven 1 as shown in figure 1A, showing the holder 4 with the vessel 5 located in the cooking cavity 6. In the vessel 5 foodstuff 7 is present. The cooking cavity 6 is bounded by an upper wall 8 being provided with a slotted hole like opening 9.

25 The upper part 3 of the microwave oven 1 is provided with a displacement device 10 mounted on top of the upper wall 8. As will be explained here below, by means of the displacement device 10 a stirrer member 11 can be moved through the opening 9 in the upper wall 8 into the vessel 5 and depending on the level of the foodstuff 7 in the vessel 5, also in the foodstuff 7.

The stirrer member 11 is plate shaped and comprises a first part 12 and a second part 13 extending under an angle with the first part 12. The first part 12 is provided at its end with two teeth 14 which will be used to stir the foodstuff 7 during and/or after cooking in the microwave oven 1 as well as eating utensil for a user to eat the prepared foodstuff from the vessel 5, after the vessel 5 has been taken out of the microwave oven 1.

The second part 13 comprises at its end with a U shaped opening 15 as well as on one side wall 16 abutment portions 17, 18.

Figure 3 shows a perspective view of a first embodiment of a displacement device 10 of the microwave oven 1.

The displacement device 10 comprises a holder 20 for a number of stirring members 11 being stacked upon each other in a stacking direction indicated by arrow P2 whereby plate-shaped surfaces of adjacent stirring members 11 being in abutment with each other. The stack 21 of stirring members 11 is located on the holder 20 and is movable by means of a slidable pushing member 22 under spring force of springs 23 in the stacking direction indicated by arrow P2. The slidable pushing member 22 forms a transport mechanism. On a side remote of the pushing member 22 a separating device 24 is located. The separating device 24 comprises a pivoting mechanism 25 being actuated by a stepping motor 26.

Figures 4A-4M show detailed side views of the displacement device 10 in several different positions during the insertion of the stirring member 11 into the vessel 5.

In figure 4A the pivoting mechanism 25 is in its initial position. The pivoting mechanism 25 comprises a metal plate 27 being pivotable about a pivot axis 43 in and opposite to a pivot direction indicated by arrow P3. The metal plate 27 is connected to a receiving member 28 for receiving a stirrer member 11. The receiving member 28 comprises a longitudinal slot 29 wherein a pen 30 is slidable movable. The pen 30 is connected to a bearing 31 (see figure 4B2) which can roll over a curved path 32 of a frame part 33. Connected to the pen 30' is a spring (not visible) which is connected with an end remote of the pen 30' to pen 34.

The receiving member 28 also comprises a slot 35 in which a pen 36 can insert and slide.

At a distance from the pen 36 a pen 37 is located being movable in a direction parallel to the stacking direction indicated by arrow P2.

5 To insert a stirring member 11 into the receiving member 28 the pivoting mechanism 25 is being pivoted in the direction as indicated by arrow P3 to the position as shown in figure 4B1.

10 In said position, the first stirring member 11 of the stack 21 is being moved under spring force of springs 23 into a stirring member receiving slot 38 of the receiving member 28. In this position the pen 30 is located in the U-shaped opening 15, the pen 36 is located opposite the abutment portion 17 and the pen 37 is located opposite the abutment portion 18 of the stirrer member 11.

15 When moving the receiving member 28 to the position as shown in figure 4B1 and an enlarged part thereof as shown in figure 4B2, the bearing 31 rolls over the curved path 32 of the frame part 33, thereby tensioning the spring connected to the pen 30'. In this position the bearing 31 and the pen 30 are located the furthest away from the pen 34.

20 After the stirring member 11 is being inserted into the receiving member 28, the receiving member 28 together with the stirring member 11 are being pivoted in a direction opposite to arrow P3 (see figure 4C), thereby moving the stirring member 11 through the opening 9 in the upper wall 8 into the cooking cavity 6. The bearing 31 with pen 30 rolls over the curved path 32 of the frame part 33 whereby the distance between the bearing 31 and the pen 37 gets smaller. The pen 30 will be moved under spring force slightly in the direction indicated by arrow P4
25 against a wall of the U-shaped opening 15. Due to this movement the abutment portion 17 will become in abutment with pen 36 preventing further movement of the stirrer member 11 in the direction indicated by arrow P4.

In the steps as shown in figures 4D and 4E the receiving member 28 together with the stirring member 11 are being pivoted further in the direction opposite to

arrow P3 until a stopping member 39 connected to pen 36 via element 40 abuts against a stop 41 of frame part 33.

By further pivoting the receiving member 28 together with the stirring member 11 in the direction opposite to arrow P3, the slot 35 and the abutment portion 17 moves away from the pen 36, so that the movement of the stirring member 11 in the direction as indicated by arrow P4 is no longer prevented (see figure 4F) due to which the stirring member 11 will be moved under spring force on pen 30' in the direction as indicated by arrow P4 (see figures 4F, 4G) until the abutment portion 17 rests against the pen 37 (see figure 4H). In figure 4H it can be seen that the bearing 31 with pen 30 now rests again on the curved path 32.

The stirring member 11 is now located in the vessel 5 and if the level of the foodstuff 7 in the vessel 5 is high enough, the stirring member 11 will also be located in the foodstuff 7.

The microwave oven 1 can be switched on or already be switched on, whereby the foodstuff is exposed to microwave radiation. During this process, the vessel 5 will be rotated in a manner well known in the art by means of the drive means about a rotating axis 42. The receiving member 28 together with the stirring member 11 will be swivelled by swivelling it about pivot axis 43 between an angle A1 (figure 4J) of for example 20-30, like 26 degrees and an angle A2 (figure 4K) of for example 10-20, like 15 degrees. The angle A1, A2 can be amended depending on the desired displacement during swivelling, the size of the vessel 5, the size and shape of the stirring member 11. The total length of the stirring member 11 can be between several centimetres up to 20 or 30 centimetres, depending a.o. on the size of the vessel 5. Preferably the stirring member 11 is being swivelled from at or about a wall of the vessel till near or beyond the centre line of the vessel 5.

By the combined motion of rotating the vessel 5 about rotating axis 42 and swivelling the stirrer member 11 about pivot axis 43 extending perpendicular to the rotating axis 42 a good stirring of the foodstuff occurs, thereby preventing hotspots, as well as mixing and cutting the foodstuff. The rotation speed can be in

the range of 0,5-100 rpm, preferably 1-60 rpm. The swivel speed can be in the range of 2-100, preferably 3-60 swivels per minute.

As soon as the foodstuff is ready, the receiving member 28 together with the stirring member 11 are being pivoted further in the direction opposite to arrow P₃ to an angle A₃ (figure 4L) of for example 6 degrees. When moving to this angle A₃, the pen 37 is being moved in the stacking direction P₂, so that the abutment portion 17 is no longer in abutment with the pen 37. This forms a releasing device.

By opening the microwave oven 1 to the position as shown in figure 1B, the stirrer member 11 will fall out of the receiving member 28 under gravity and/or will stick to the foodstuff 7 and be pulled out of the receiving member 28 by the foodstuff. If not, the user can pull the stirrer member 11 out the receiving member 28 by himself (figure 4M).

Figures 5 and 6 show perspective views of a second embodiment of a displacement device 110 of the microwave oven 1 as shown in figure 1A and 1B for moving a stirrer member 111 into the cooking cavity. The stirrer member 111 comprises a longitudinal strip being curved about an axis extending in the longitudinal direction of the stirrer member 111. Such stirrer members 111 can easily be stacked and separated by moving for example the lowest stirrer member 111 in a direction indicated by arrow P₁₁. The displacement device 110 comprises a number of rotating rollers 112, 113, 114 through which a separated single stirrer member 111 can be guided in a direction indicated by arrow P₁₂ whereby the curved stirrer member 111 is forced against spring force of the stirrer member 111 to a flat stirrer member 111' in which it is inserted by means of rollers 116 through the opening 9 in the upper wall 8 of the cooking cavity 6. As soon as the flat stirrer member 111' is no longer located between the rollers 112, 113, 114, it will return under spring force into its curved position. During operating the microwave oven 1 the stirrer member 111 will be held at one end near the upper wall 8 and be prevented from moving downwardly. It can be kept still during rotation of the vessel 5, it can be swivelled or it can be rotated as well as being swivelled.

Figures 7 and 8 show perspective views of a third embodiment of a displacement device 210 of the microwave oven 1 as shown in figure 1A and 1B for moving stirrer members 211 to the cooking cavity. The stirrer member 211 comprises a handle 212 as well as a spoon shaped part 213. The stirrer members 211 are stackable whereby main surfaces of the stirrer members 211 are in abutment with each other. After moving one stirrer member 211 away from the stack 214 in a direction P21, the stirrer member 211 is moved by the displacement device 210 in the directions as indicated by arrows P22 and P23 through the opening 9 in the upper wall 8 of the cooking cavity 6 and into the vessel 5. The thickened end 215 of the stirrer member 211 can be held in the displacement device 210 during operating the microwave oven 1 and be released after completing the cooking process.

Figures 9-12 are perspective views of a fourth embodiment of a displacement device 310 of the microwave oven as shown in figure 1A and 1B for moving stirrer members 311 to the cooking cavity. The stirrer member 311 comprises a shaft 312 provided at one end with a ring shaped part 313 and at the other end with a knife shaped part 314. The stirrer members 311 can be stacked by mounting the ring shaped parts 313 on a rod 315 of the displacement device 310. The rod 315 extends horizontally over a first part 316, whereby the stirrer members 311 are stacked on this horizontally first part 316, comprises a curved part 317 and a second part 318 extending downwardly towards the vessel 5. A separated stirrer member 311 is being moved along the first part 316, the curved part 317 and the second part 318, until the ring shaped part 313 of the stirrer member 311 abuts against a thickened end (not visible) of the second part 318. It may also simply rest on a bottom of the vessel 5. Preferably the ring shaped part 313 comprises a small slot 319, so that the ring shaped part 313 can be opened against spring force to remove the ring shaped part 313 from the second part 318.

The movement of the stirrer member 11, 111, 211, 311 can also be done when the microwave oven 1 is open, so that by closing the microwave oven 1 the stirrer member 11, 111, 211, 311 is directly inserted into the vessel 5.

It also possible to only rotate the vessel 5 with respect to the stirrer member 11, 111, 211, 311 without any swivelling motion, whereby either the vessel 5 or the stirrer member 11, 111, 211, 311 or both the vessel 5 and the stirrer member 11, 111, 211, 311 are being rotated. It is also possible to rotate as well as to swivel the stirrer member 11, 111, 211, 311.

The rotating axis 42 extends preferably vertically but, if desired it can extend under an angle with the vertical.

It is also possible to swivel the stirring member 11 between opposite walls of the vessel 5.

10 The microwave oven can have any suitable shape.

For different foodstuffs the time, temperatures, swivel speeds and rotational speeds etc. can easily experimentally be determined.

It is possible let the stirrer member drop into the foodstuff during or just after cooking or just before bringing the microwave oven 1 to the open position as shown in figure 1B.

Each stirrer member 11, 111, 211, 311 preferably has the following features.

It is flat so that it can be stacked onto each other. This reduces storage space that could make the corresponding displacement device 10, 110, 210, 310 relatively small.

20 Each stirrer member 11, 111, 211, 311 contains a sliding edge for insertion/guidance by the te corresponding displacement device 10, 110, 210, 310.

The stirrer member 11, 111, 211, 311 comprises a stopper part limiting the length over which it is inserted in the vessel during cooking.

25 The stirrer member 11, 111, 211, 311 may comprise a cutting part to cut for example the scrambled egg. Preferably it is not so sharp that a user can accidentally cut himself.

30 The embodiments as shown above have been described regarding a microwave oven. The same results can be obtained by using a steam oven instead of a microwave oven or by using another kind of oven suitable for heating the foodstuff.

Microwave has the advantage that it does not require any heat up cycle, which is efficient. Steam can be beneficial when higher cooking temperatures are required. Since steam will add moisture to the foodstuff, using steam is advantageous when drying out of food, during heating, becomes critical.

5

LIST OF REFERENCE SIGNS

	1	microwave oven
	2	lower part
10	3	upper part
	4	holder
	5	vessel
	6	cooking cavity
	7	foodstuff
15	8	upper wall
	9	opening
	10	displacement device
	11	stirrer member
	12	first part
20	13	second part
	14	teeth
	15	U shaped opening
	16	wall
	17	abutment portion
25	18	abutment portion
	20	holder
	21	stack
	22	pushing member
	23	spring
30	24	separating device

	25	pivoting device
	26	stepping motor
	27	metal plate
	28	receiving member
5	29	longitudinal slot
	30	pen
	30'	pen
	31	bearing
	32	curved path
10	33	frame part
	34	pen
	35	slot
	36	pen
	37	pen
15	38	receiving slot
	39	stopping member
	40	element
	41	stop
	42	rotating axis
20	43	pivot axis
	110	displacement device
	111	curved stirrer member
	111'	flat stirrer member
	112	roller
25	113	roller
	114	roller
	116	roller
	210	displacement device
	211	stirrer member
30	212	handle

	213	spoon shaped part
	214	stack
	215	thickened end
	310	displacement device
5	311	stirrer member
	312	shaft
	313	ring shaped part
	314	knife shaped part
	315	rod
10	316	first part
	317	curved part
	318	second part
	319	slot
	A1	angle
15	A2	angle
	A3	angle
	P1	arrow
	P2	arrow
	P3	arrow
20	P4	arrow
	P21	arrow
	P22	arrow

Claims

1. An oven (1) comprising a cooking cavity (6), a stirring member (11, 111, 211, 311) extending, in use, into foodstuff (7) contained in a vessel (5) disposed in the cooking cavity (6) as well as drive means to provide, in use, relative movement between the stirring member (11, 111, 211, 311) and the vessel (5), characterized in that the oven (1) comprises a displacement device (10, 110, 210, 310) to move the stirring member (11, 111, 211, 311) from outside the cooking cavity (6) through an opening (9) in a wall (8) bounding the cooking cavity (6) into the cooking cavity (6) as well as, in use, into the vessel (5) disposed in the cooking cavity (6).
2. An oven (1) according to claim 1, characterized in that the oven comprises a holder (20) for holding a number of stirring members (11, 111, 211, 311), wherein the displacement device (10, 110, 210, 310) is provided with a separating device (24) to separate one of the stirring members (11, 111, 211, 311) from the number of stirring members (11, 111, 211, 311) located in said holder (20) and to move said first one of the number of stirring members (11, 111, 211, 311) from outside the cooking cavity (6) through the wall (8) bounding the cooking cavity (6) into the cooking cavity (6) as well as, in use, into the vessel (5) disposed in the cooking cavity (6).
3. An oven (1) according to claim 2, characterized in that the number of stirring members (11, 111, 211, 311) are stacked upon each other in the holder (20) in a stacking direction (P2), which displacement device (10, 110, 210, 310) comprises a transport device to transport the stacked number of stirring members (11, 111, 211, 311) in the stacking direction, which separating device (24) comprises a pivoting device (25) to pivot a first one of the stacked number of stirring members (11, 111, 211, 311) about a pivot axis extending parallel to the stacking direction through the opening (9) in the wall (8).

4. An oven (1) according to claim 3, characterized in that the displacement device (10, 110, 210, 310) comprises a translation device to translate the pivoted stirring member (11, 111, 211, 311) in a translation direction extending perpendicular to the pivot axis towards the vessel (5).

5

5. An oven (1) according to claim 3, characterized in that the stirring member (11, 111, 211, 311) is translated under spring force in the translation direction.

6. An oven (1) according to one of the preceding claims, characterized in that the displacement device (10, 110, 210, 310) comprises a releasing device to release the stirring member (11, 111, 211, 311) from the displacement device (10, 110, 210, 310).

7. An oven (1) according to one of the preceding claims, characterized in that the drive means comprises means to rotate, in use, the vessel with respect to the stirring member (11, 111, 211, 311) about a rotating axis (42), whilst the displacement device (10, 110, 210, 310) comprises means to swivel the stirring member (11, 111, 211, 311) about a swivel axis extending at an angle between 60-120 degrees, preferably substantially perpendicular to the rotating axis (42).

8. An oven according to one of the preceding claims, characterized in that the oven is a microwave oven, steam oven or another kind of oven.

9. A method for stirring foodstuff contained in a vessel disposed in the cooking cavity of a oven (1) by means of a stirring member (11, 111, 211, 311), whereby the vessel (5) is being relatively moved with respect to the stirring member (11, 111, 211, 311), characterized in that by means of a displacement device (10, 110, 210, 310) the stirring member (11, 111, 211, 311) is being moved from outside the cooking cavity (6) through an opening in a wall bounding the cooking cavity (6) into the cooking cavity (6) and into the vessel (5) disposed in the cooking cavity (6).

30

10. Method according to claim 8, characterized in that the oven (1) comprises a holder (20) for holding a number of stirring members (11, 111, 211, 311), wherein the displacement device (10, 110, 210, 310) is provided with a separating device, whereby one of the stirring members (11, 111, 211, 311) is being separated from the number of
5 stirring members (11, 111, 211, 311) located in said holder (20) by the separating device (24) and is being moved from outside the cooking cavity (6) through the wall bounding the cooking cavity (6) into the cooking cavity (6) and into the vessel (5) disposed in the cooking cavity (6).
- 10 11. Method according to claim 9, characterized in that the number of stirring members (11, 111, 211, 311) are stacked upon each other after which a first one of the stacked number of stirring members (11, 111, 211, 311) is being pivoted about a pivot axis extending parallel to the transport direction by through the opening (9) in the wall (8).
- 15 12. Method according to claim 10, characterized in that the pivoted stirring member (11, 111, 211, 311) is being translated in a translation direction extending perpendicular to the pivot axis towards the vessel (5).
- 20 13. Method according to claim 11, characterized in that the pivoted stirring member (11, 111, 211, 311) is translated under spring force in the translation direction.
14. Method according to one of the preceding claims 8-12, characterized in that stirring member (11, 111, 211, 311) is being released from the displacement device (10,
25 110, 210, 310) by a releasing device.
15. Method according to one of the preceding claims 8-13, characterized in that the vessel (5) is being rotated with respect to the stirring member (11, 111, 211, 311) about a rotating axis (42), whilst the one stirring member (11, 111, 211, 311) is being

swivelled about a swivel axis extending at an angle between 60-120 degrees, preferably substantially perpendicular to the rotating axis (42).

16. A method according to one of the preceding claims, characterized in that the
5 foodstuff is being heated in the oven by means of microwaves, steam or other means.

17. A stirrer member (11, 111, 211, 311) suitable for a oven (1) according to one of
the preceding claims 1-8 characterized in that the stirrer member (11, 111, 211, 311)
10 comprises at least a first part and a second part, wherein the first part is suitable to be used to stir the foodstuff during and/or after cooking in the oven (1), whilst the second part is suitable to be moved by means of the displacement device (10) in the vessel (5).

18. A stirrer member (11, 111, 211, 311) according to claim 17, characterized in that
15 the first part of the stirrer member (11, 111, 211, 311) comprises an eating utensil for a user to eat the prepared foodstuff from the vessel (5), after the vessel (5) has been taken out of the oven (1),

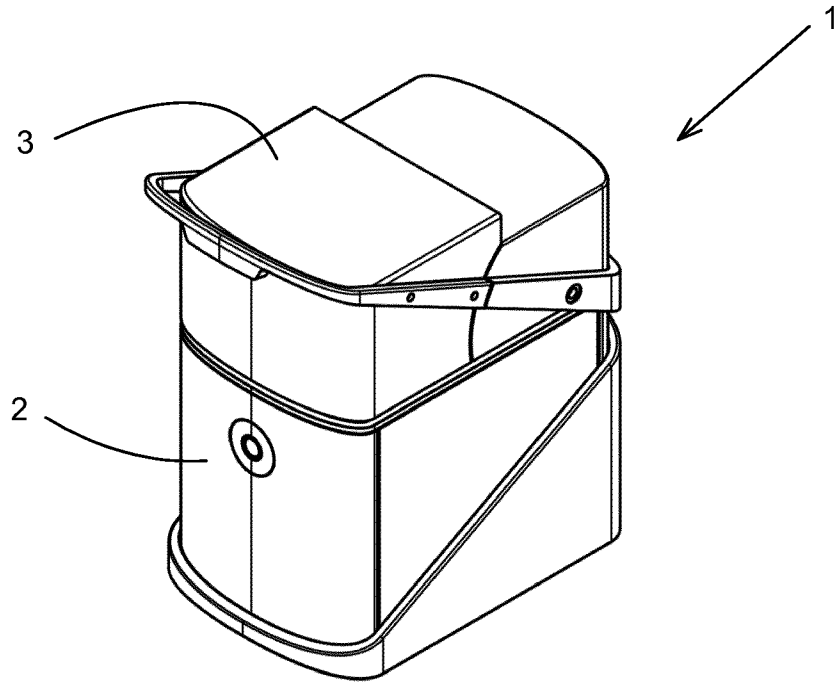

Fig. 1A

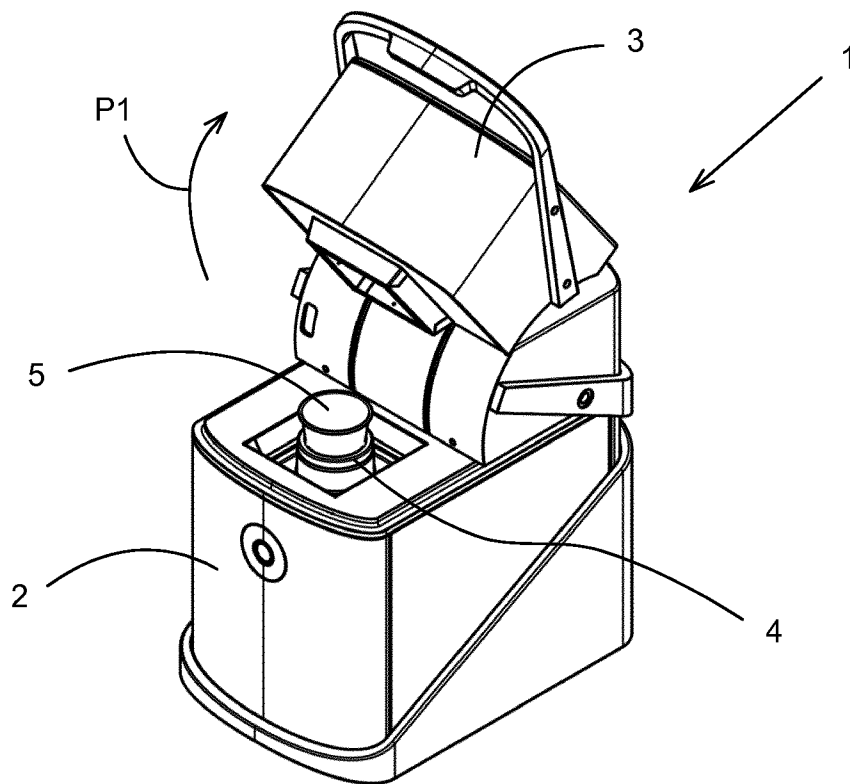

Fig. 1B

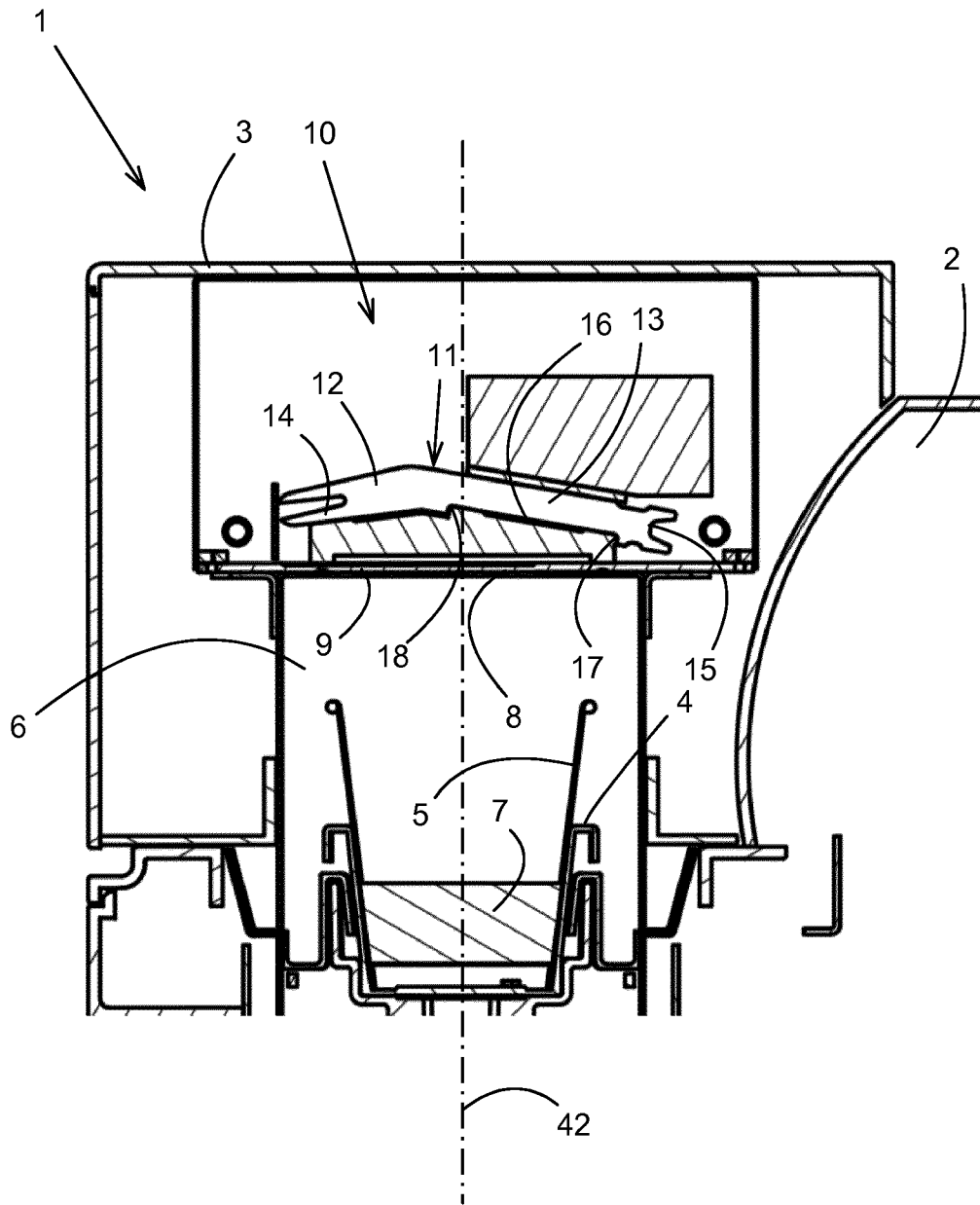

Fig. 2A

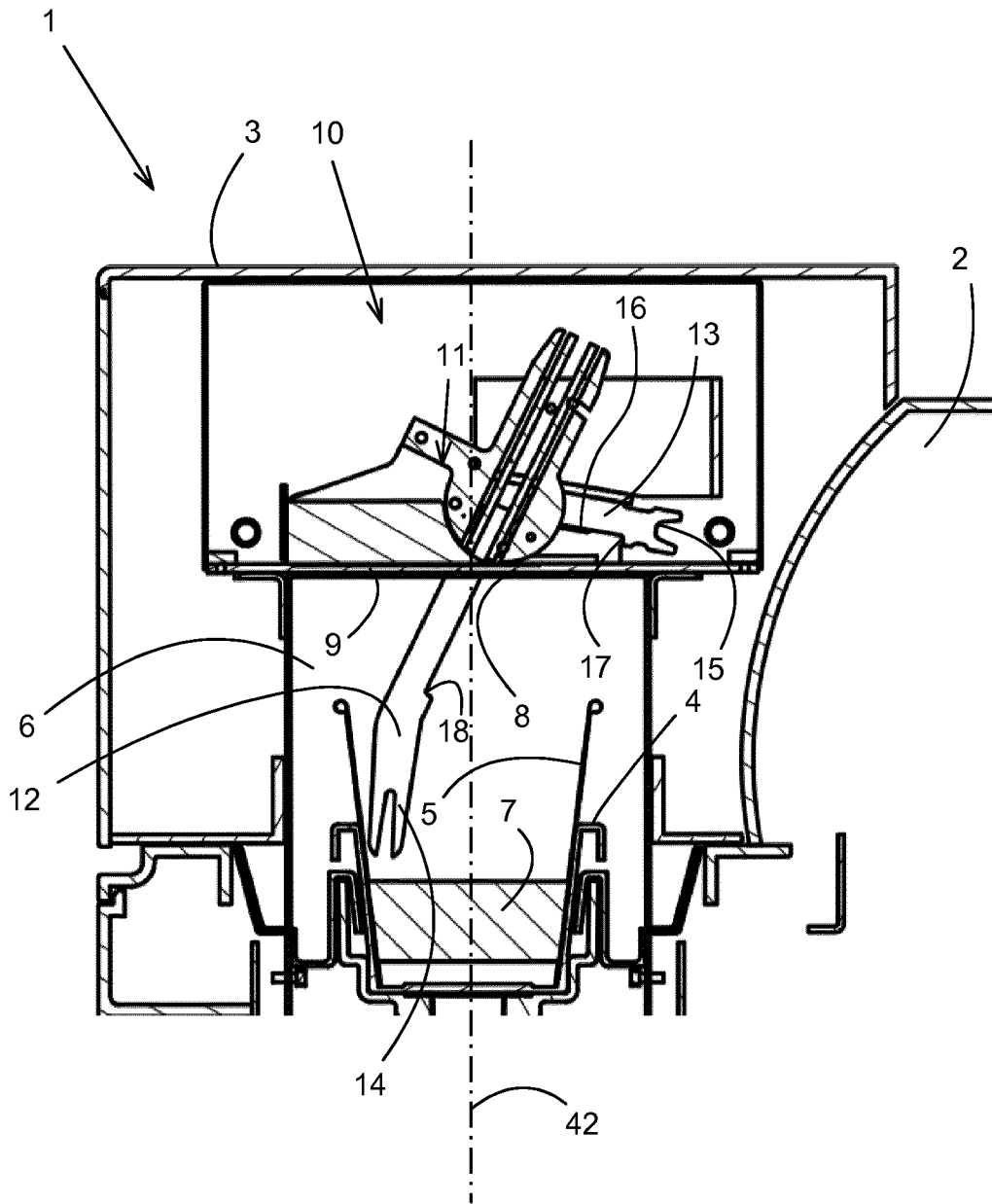

Fig. 2B

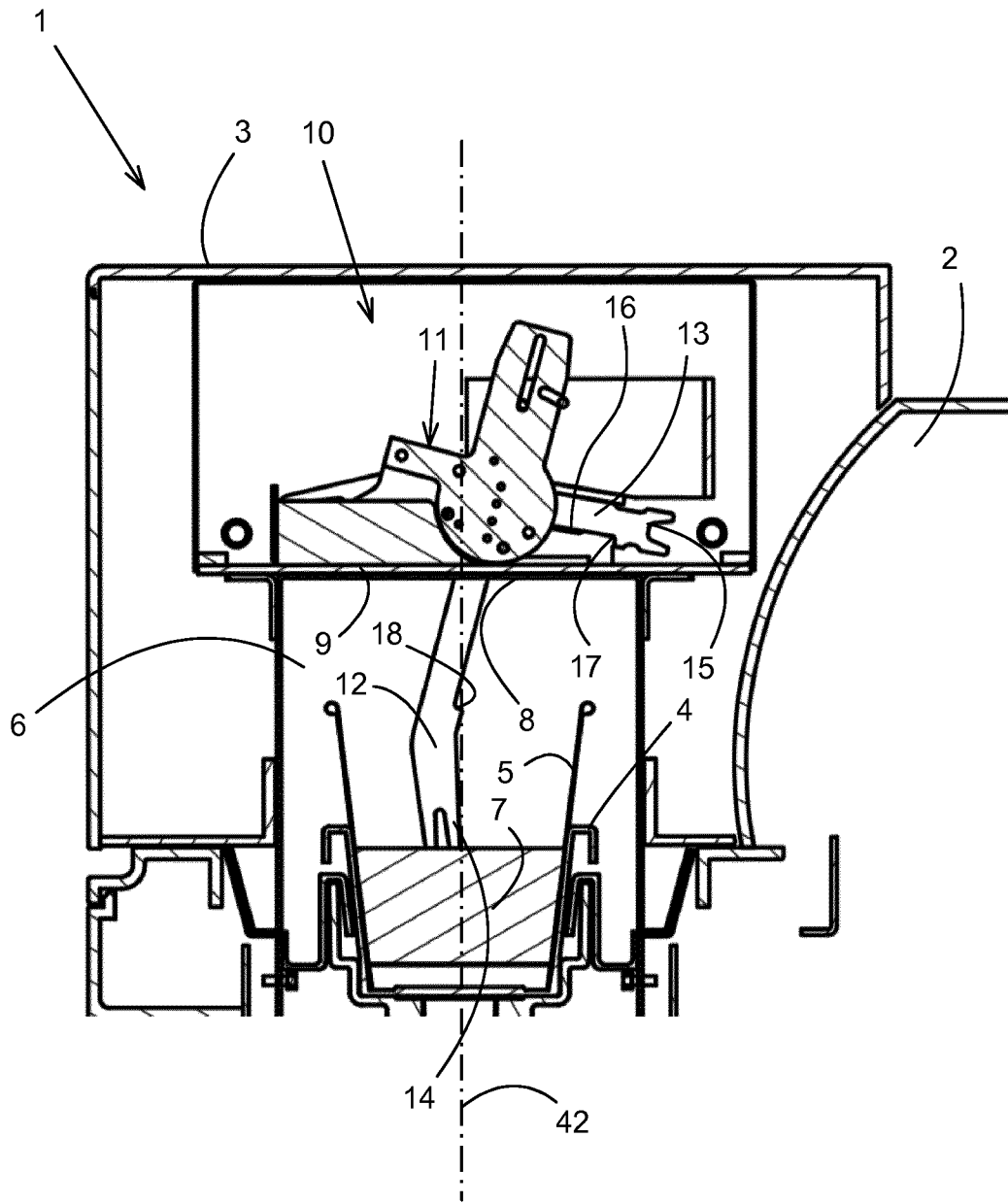

Fig. 2C

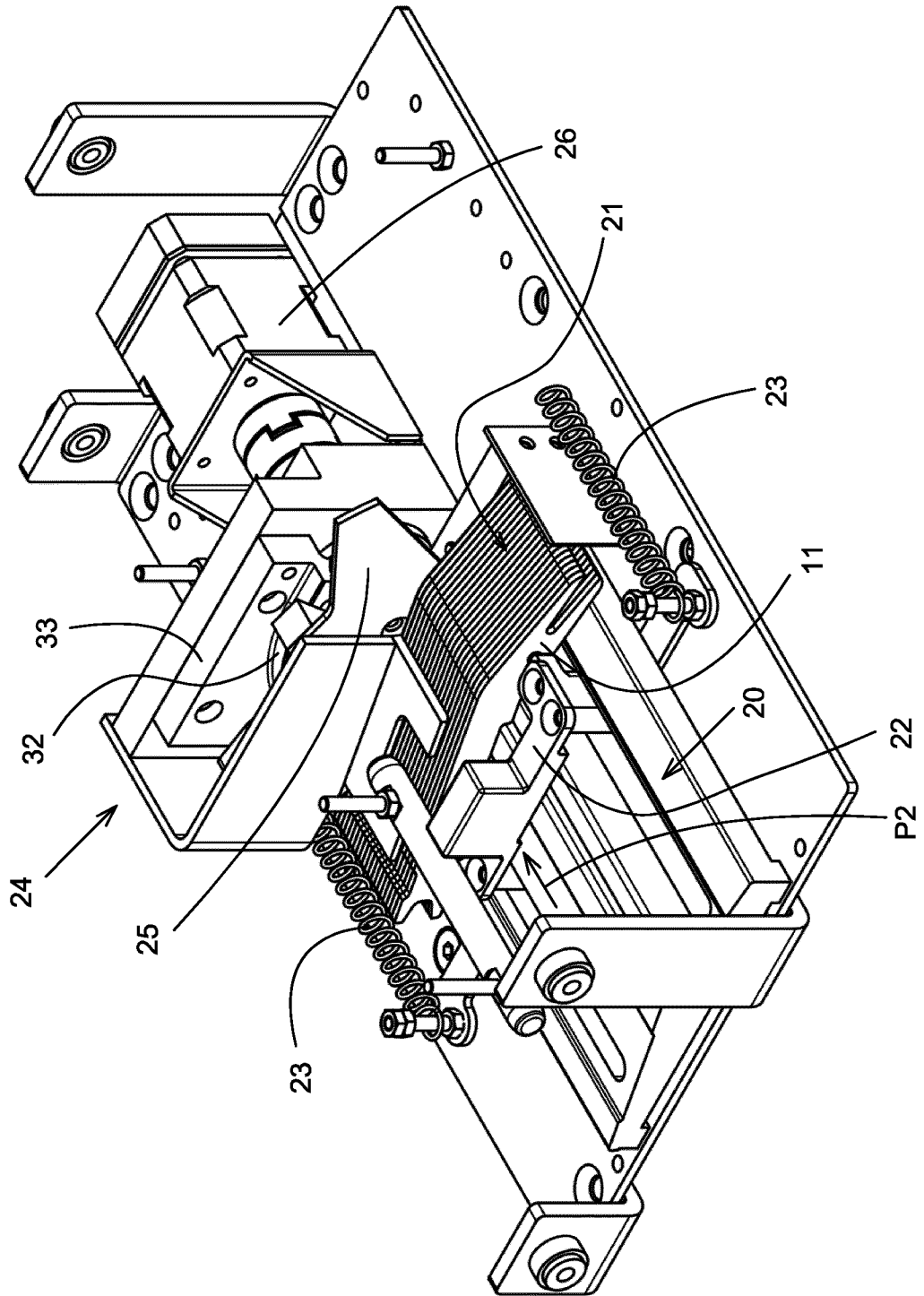

Fig. 3

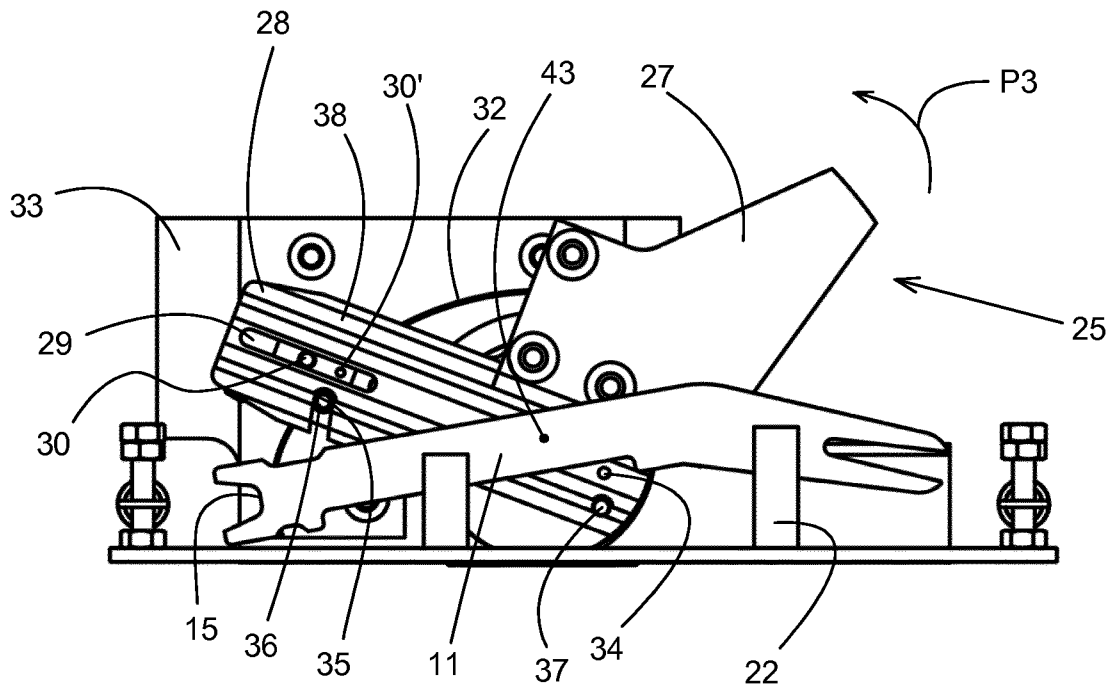

Fig. 4A

7/23

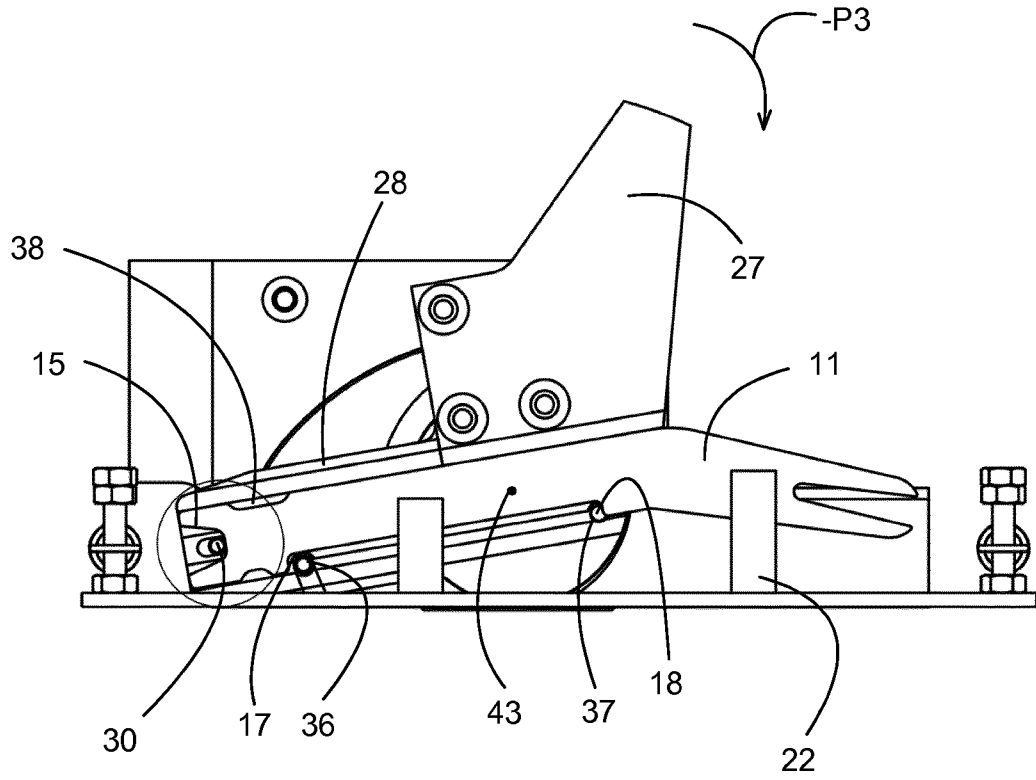

Fig. 4B1

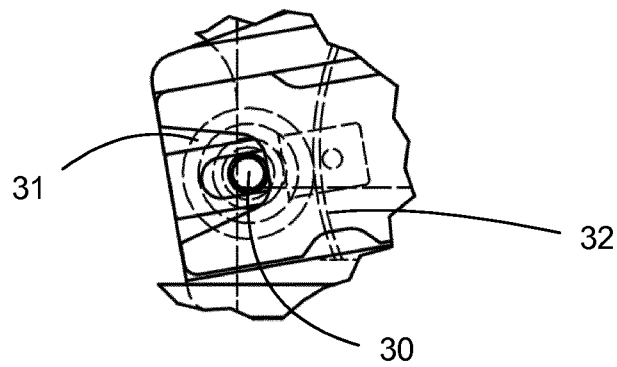

Fig. 4B2

8/23

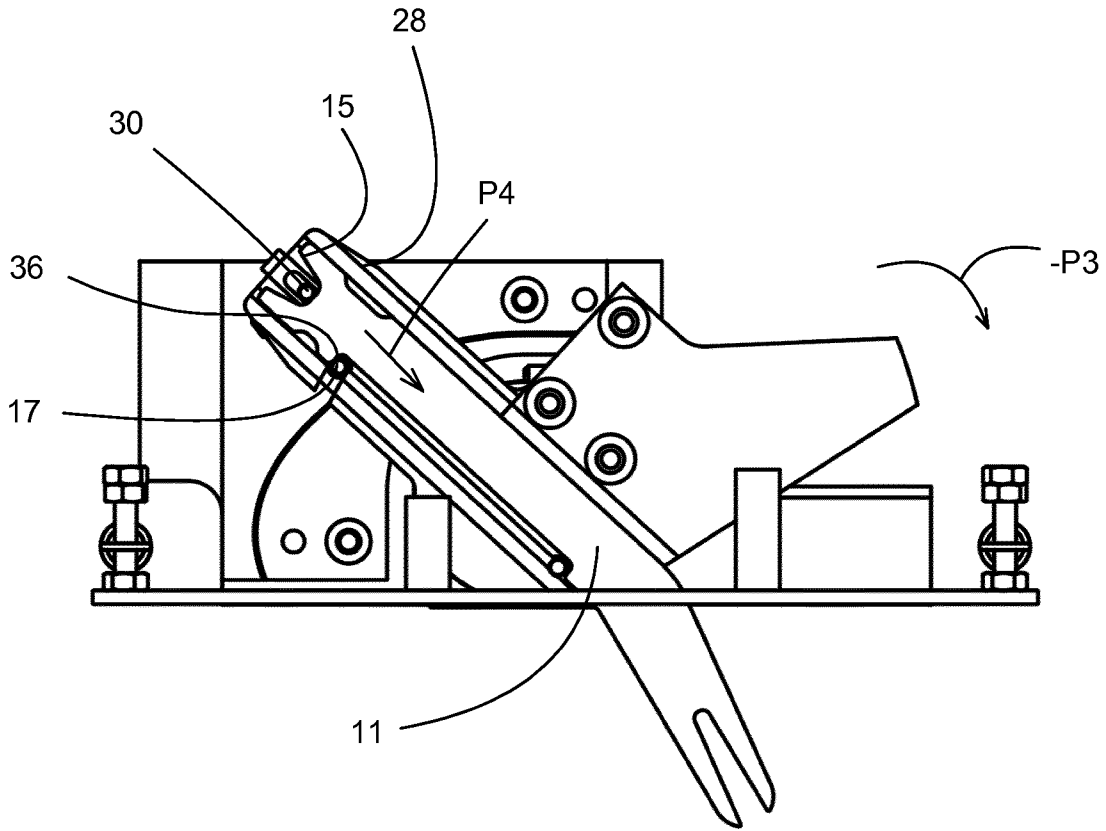

Fig. 4C

9/23

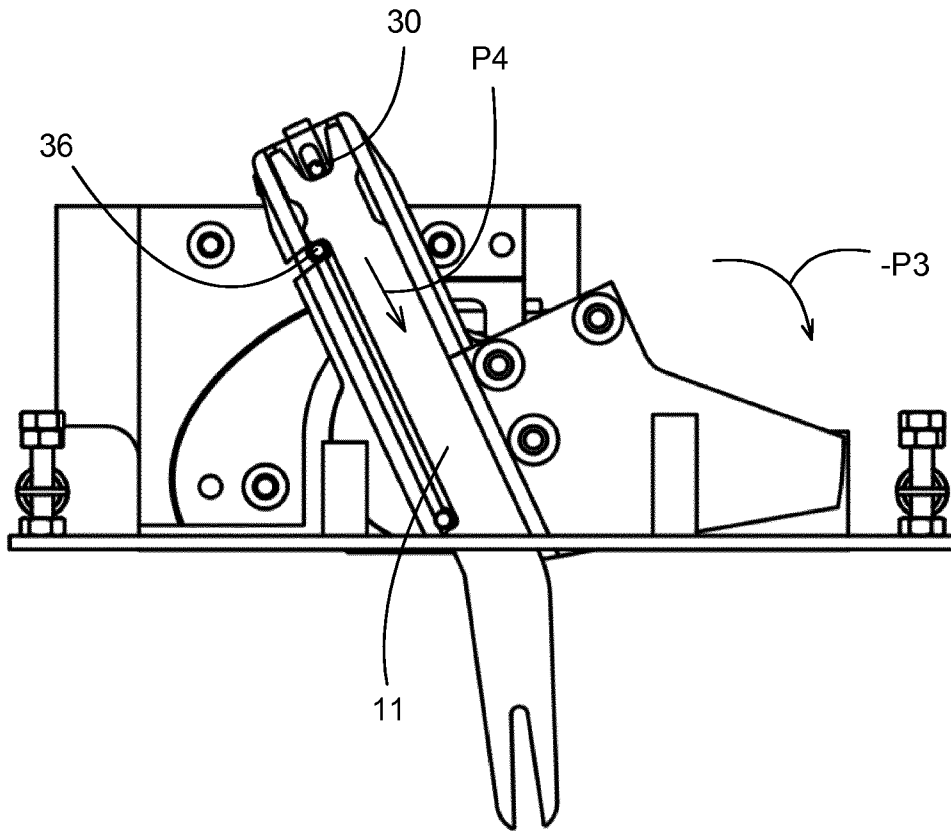

Fig. 4D

10/23

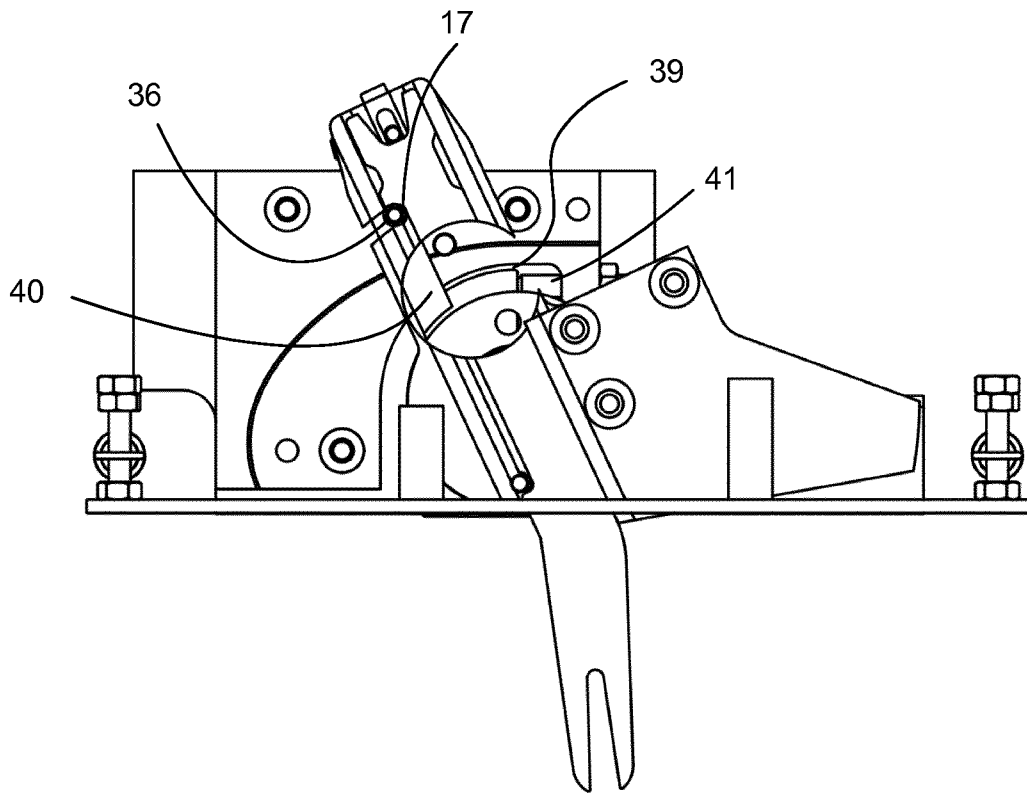

Fig. 4E

11/23

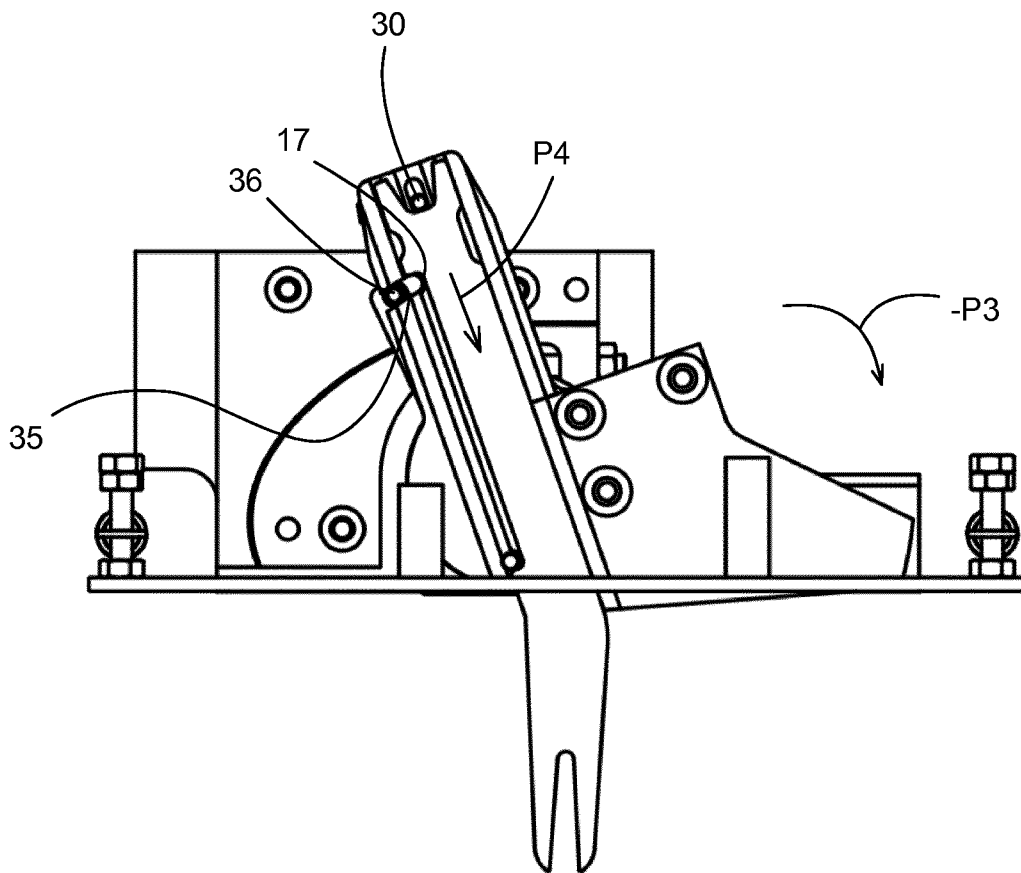

Fig. 4F

12/23

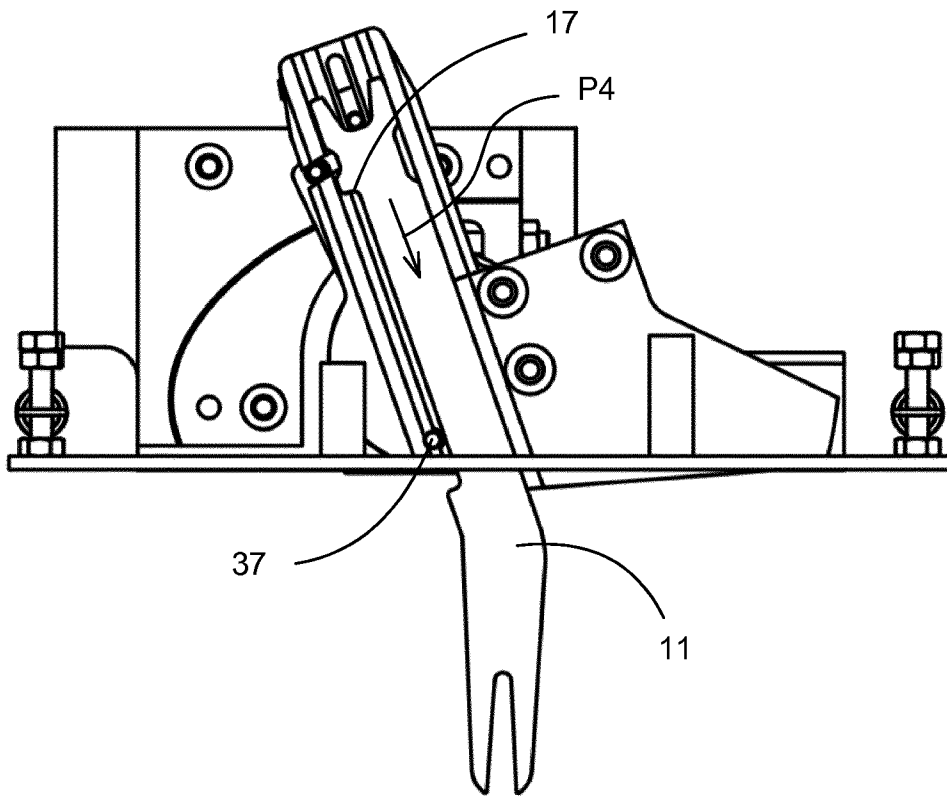

Fig. 4G

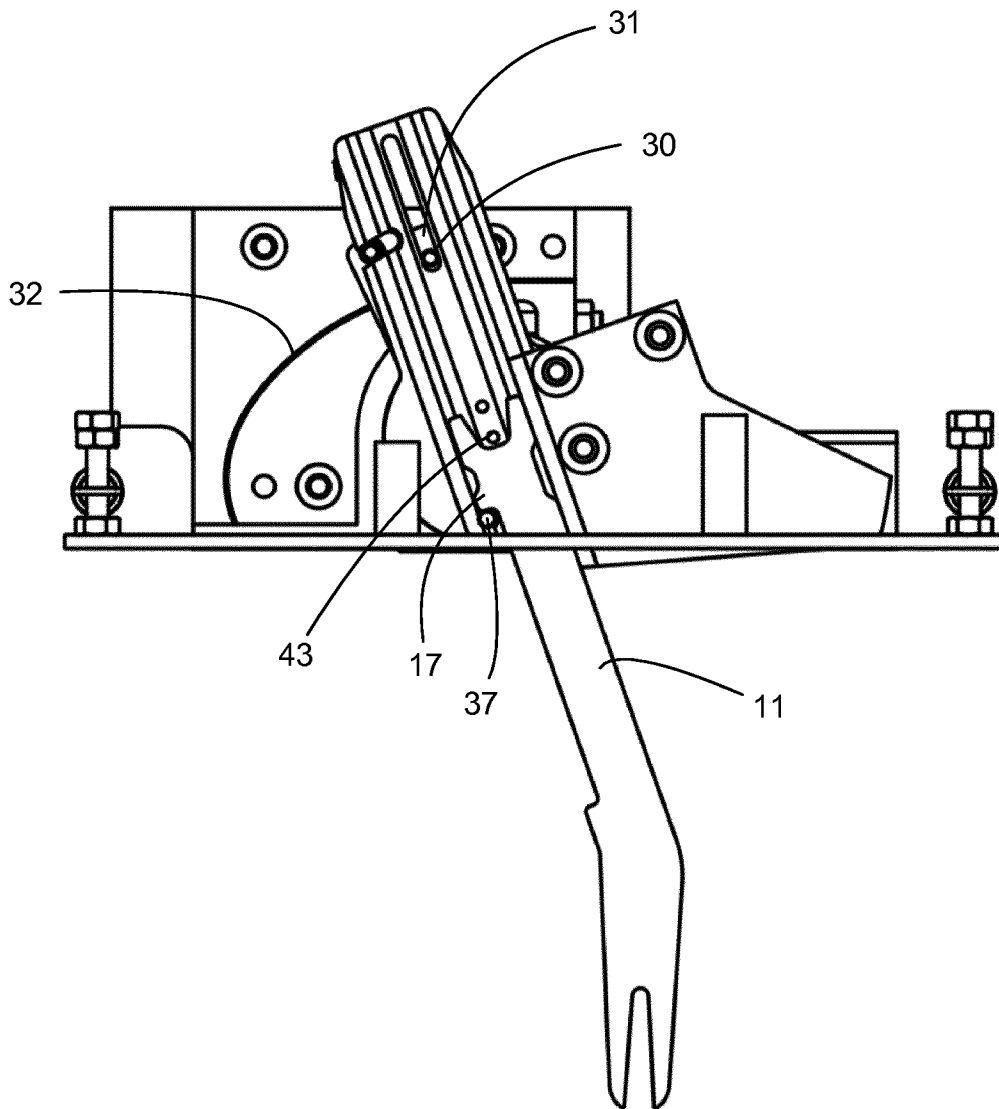

Fig. 4H

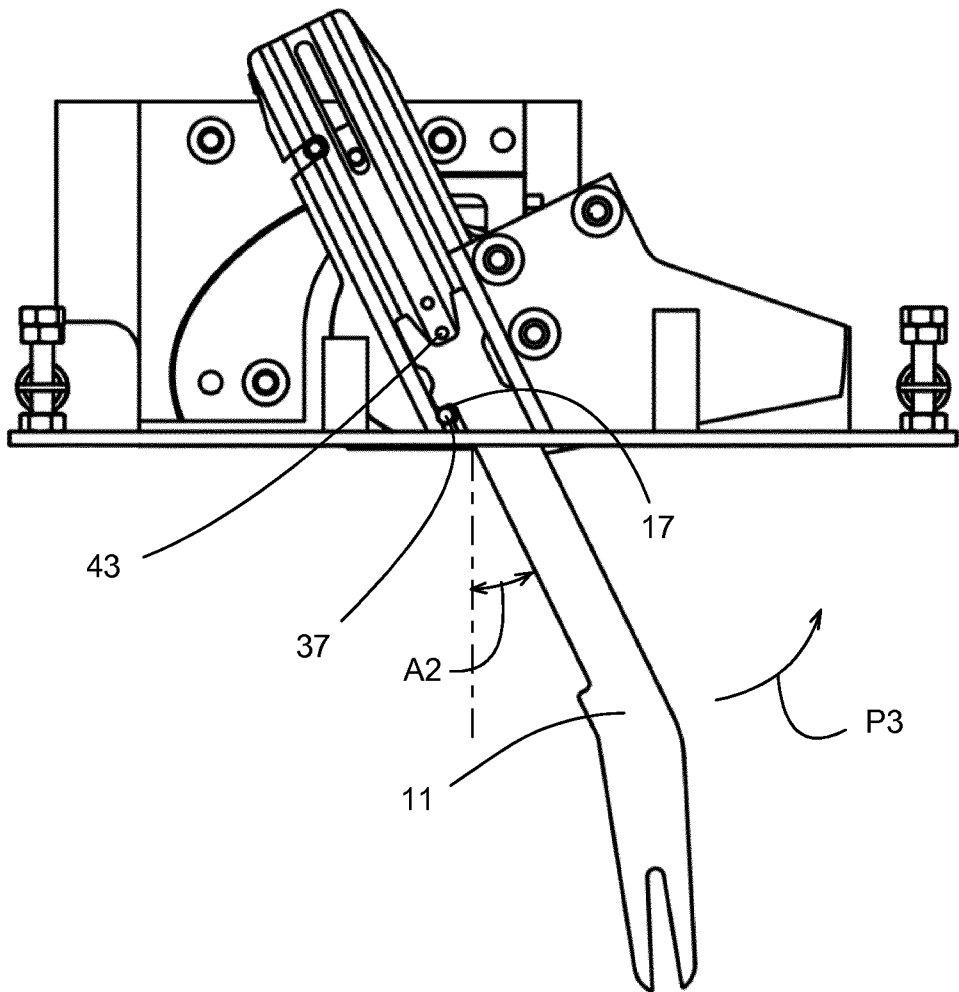

Fig. 4J

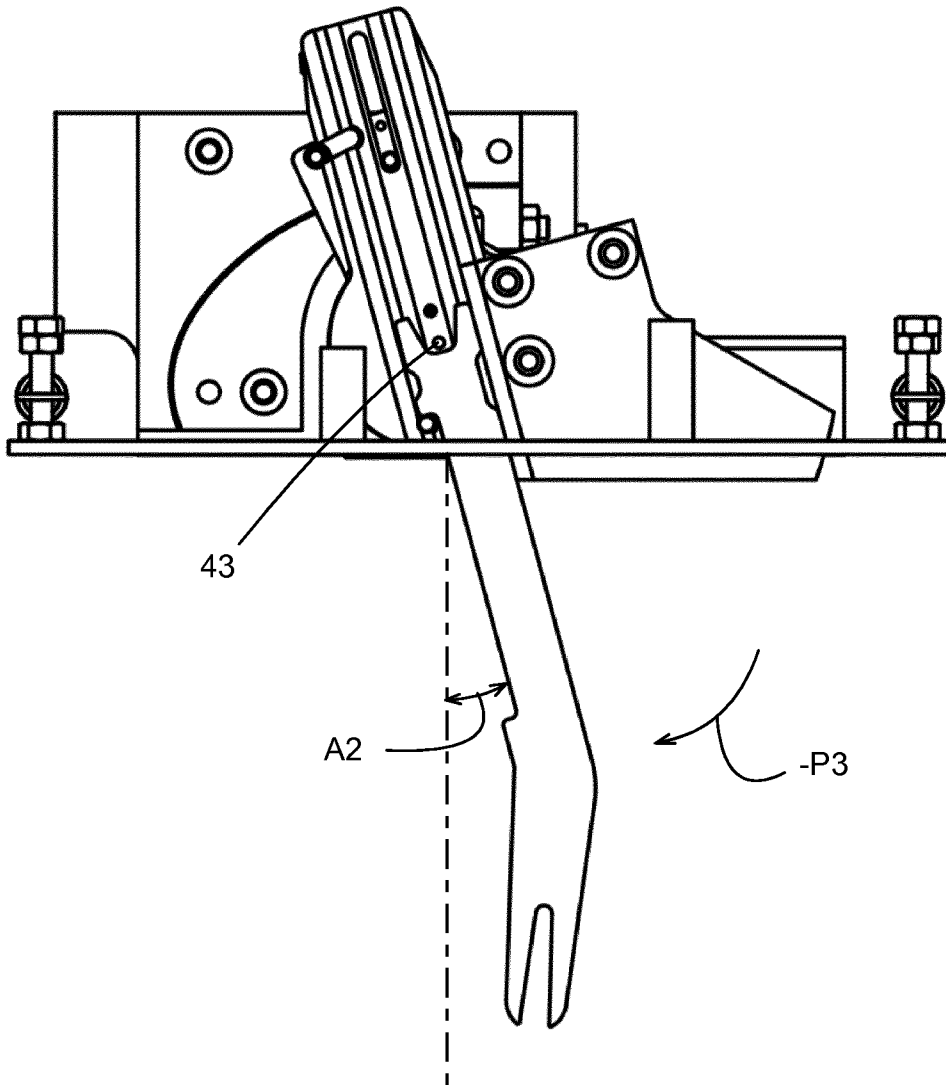

Fig. 4K

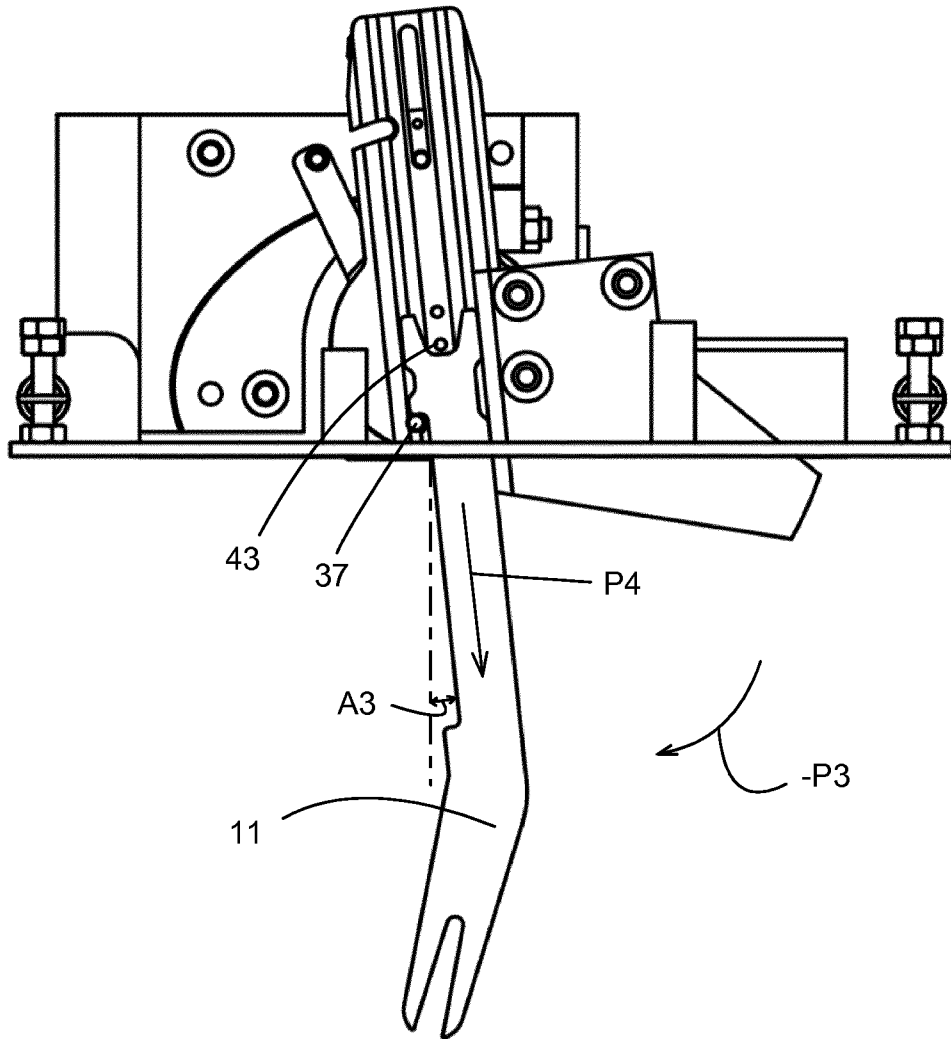

Fig. 4L

17/23

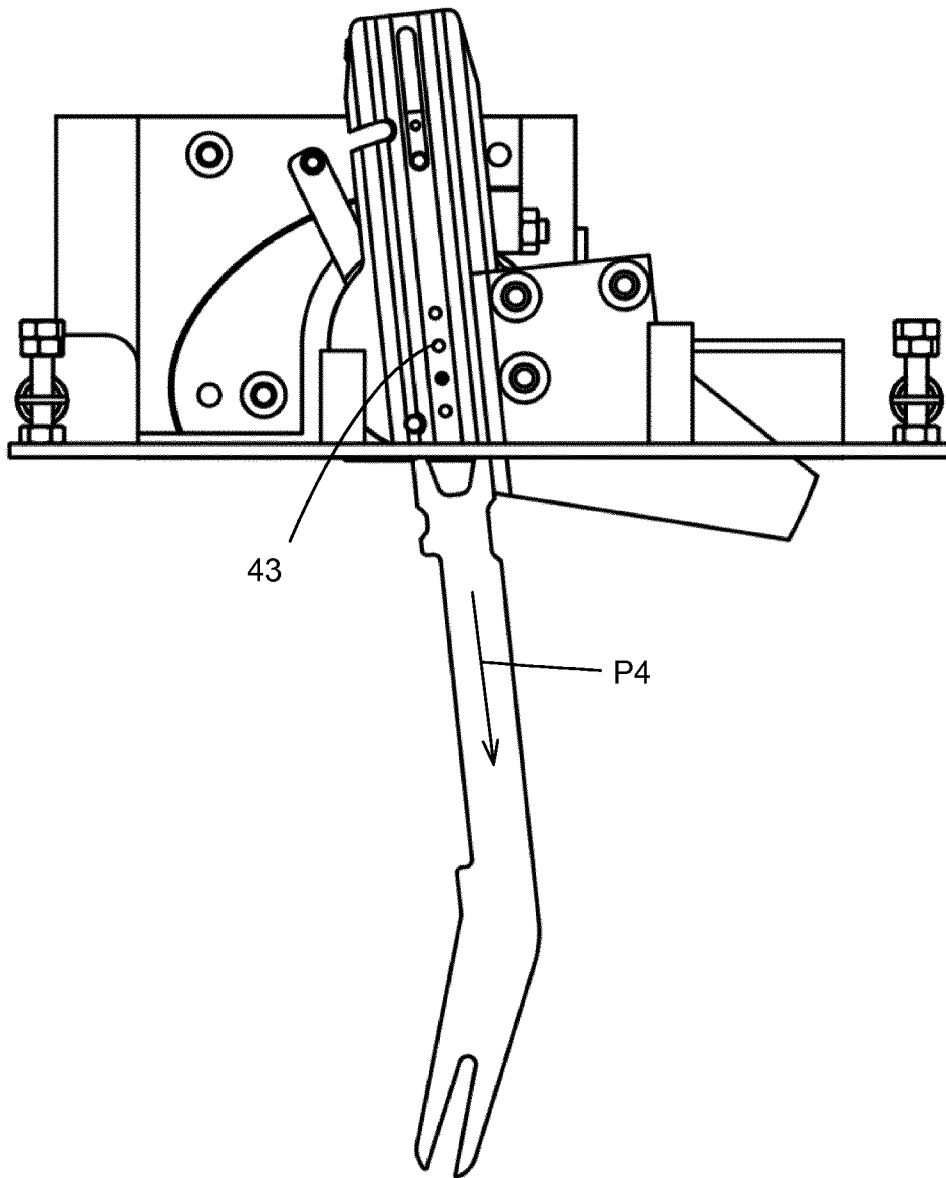

Fig. 4M

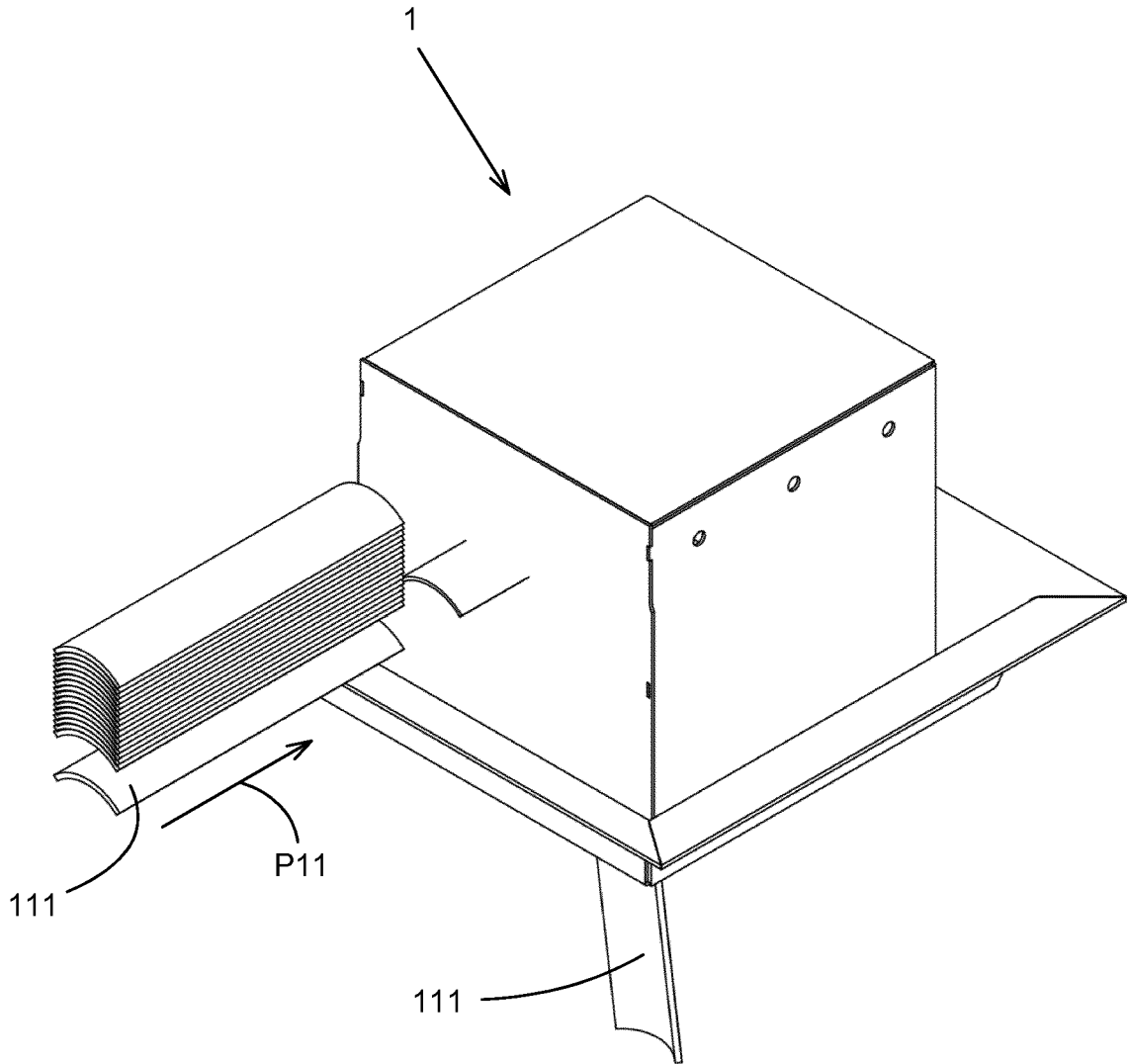

Fig. 5

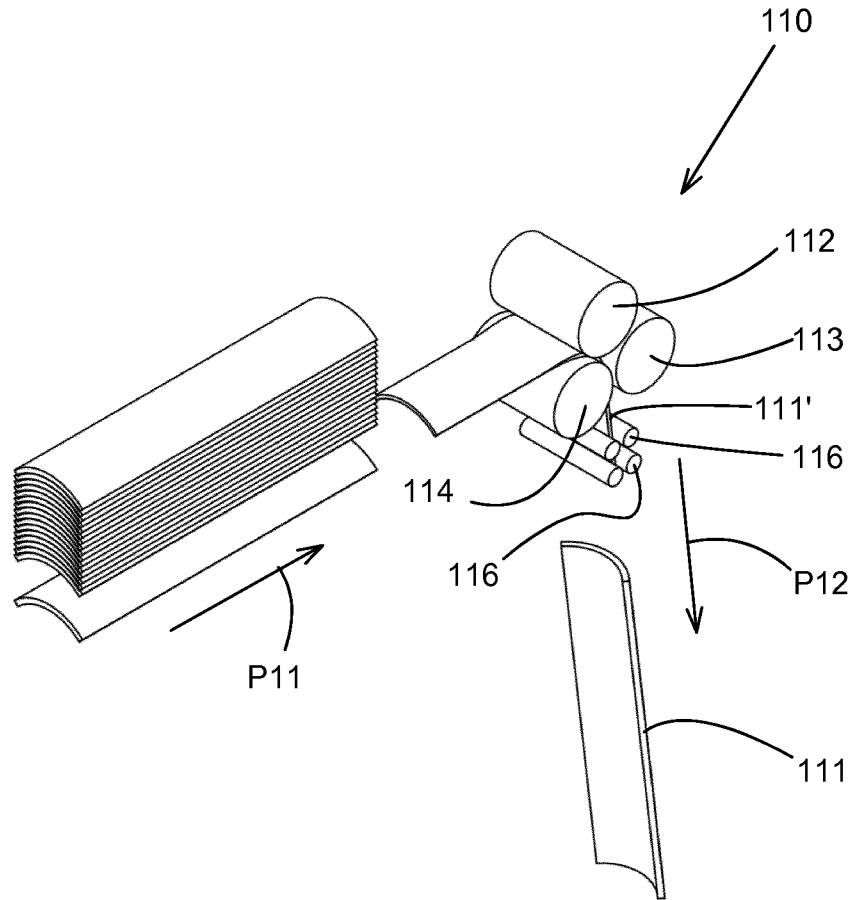

Fig. 6

20/23

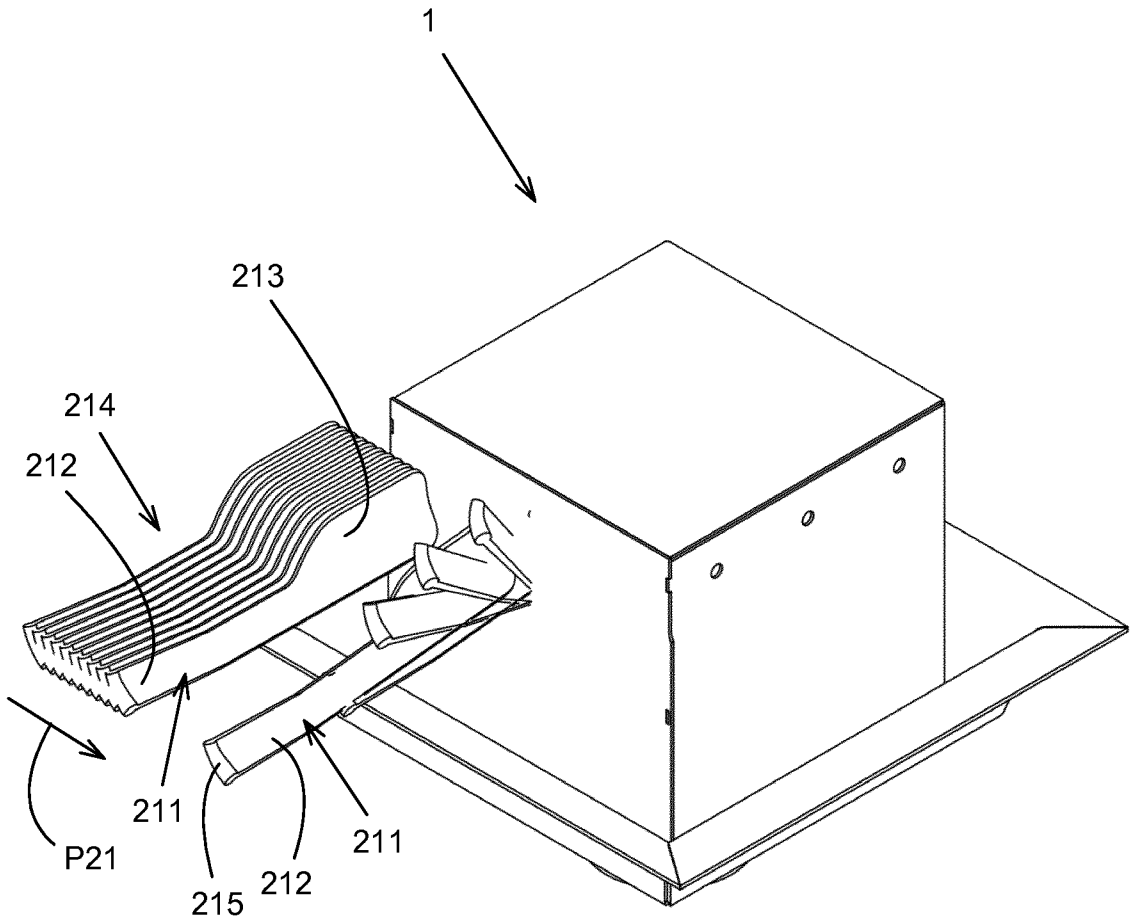

Fig. 7

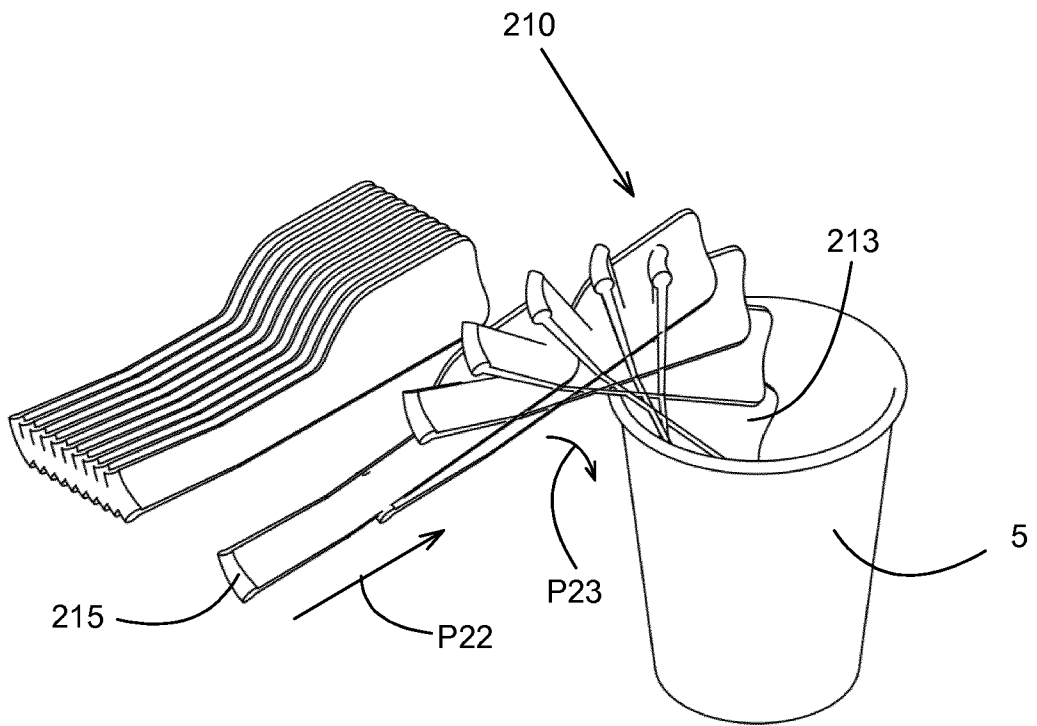

Fig. 8

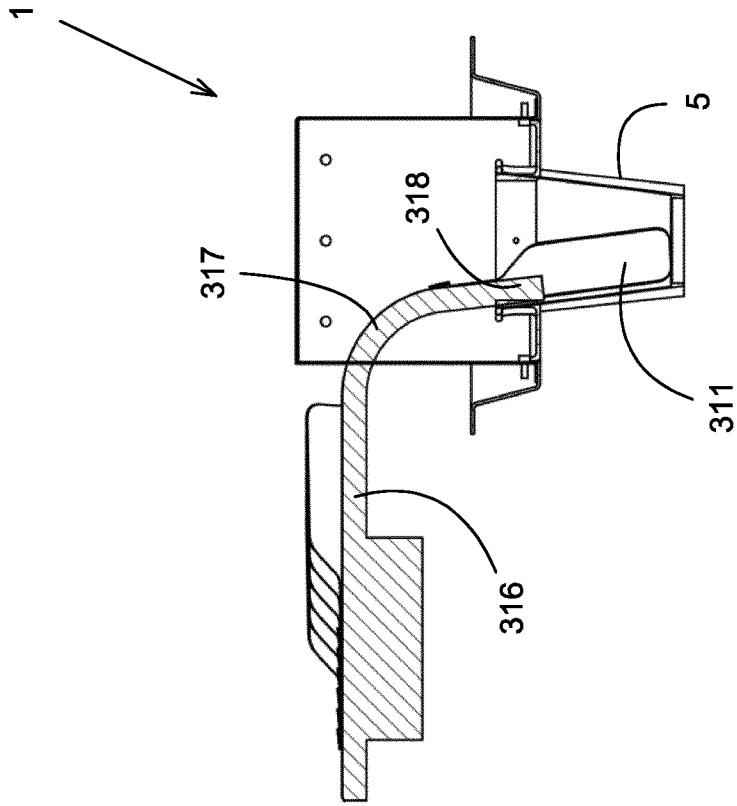

Fig. 9

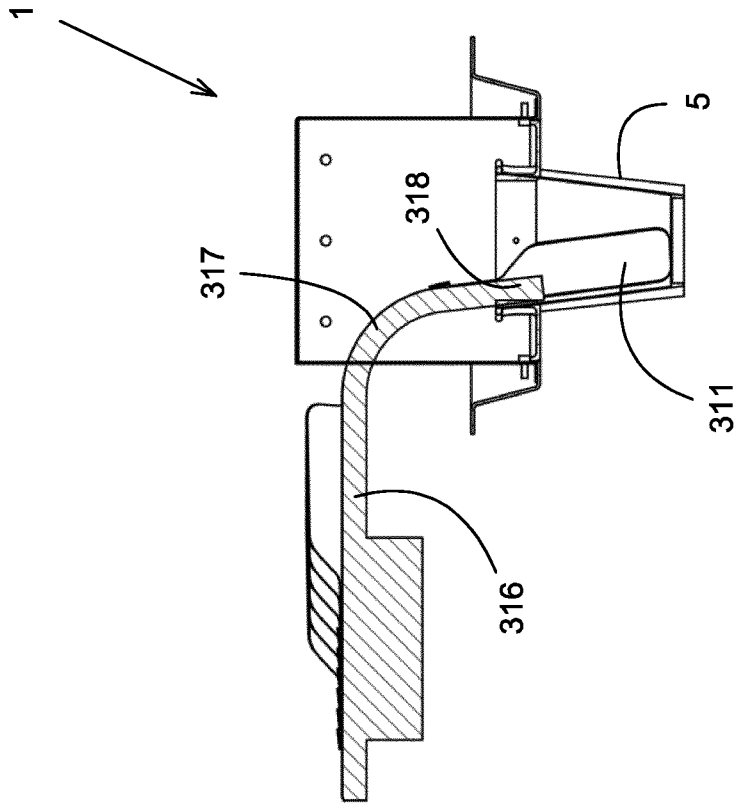

Fig. 10

23/23

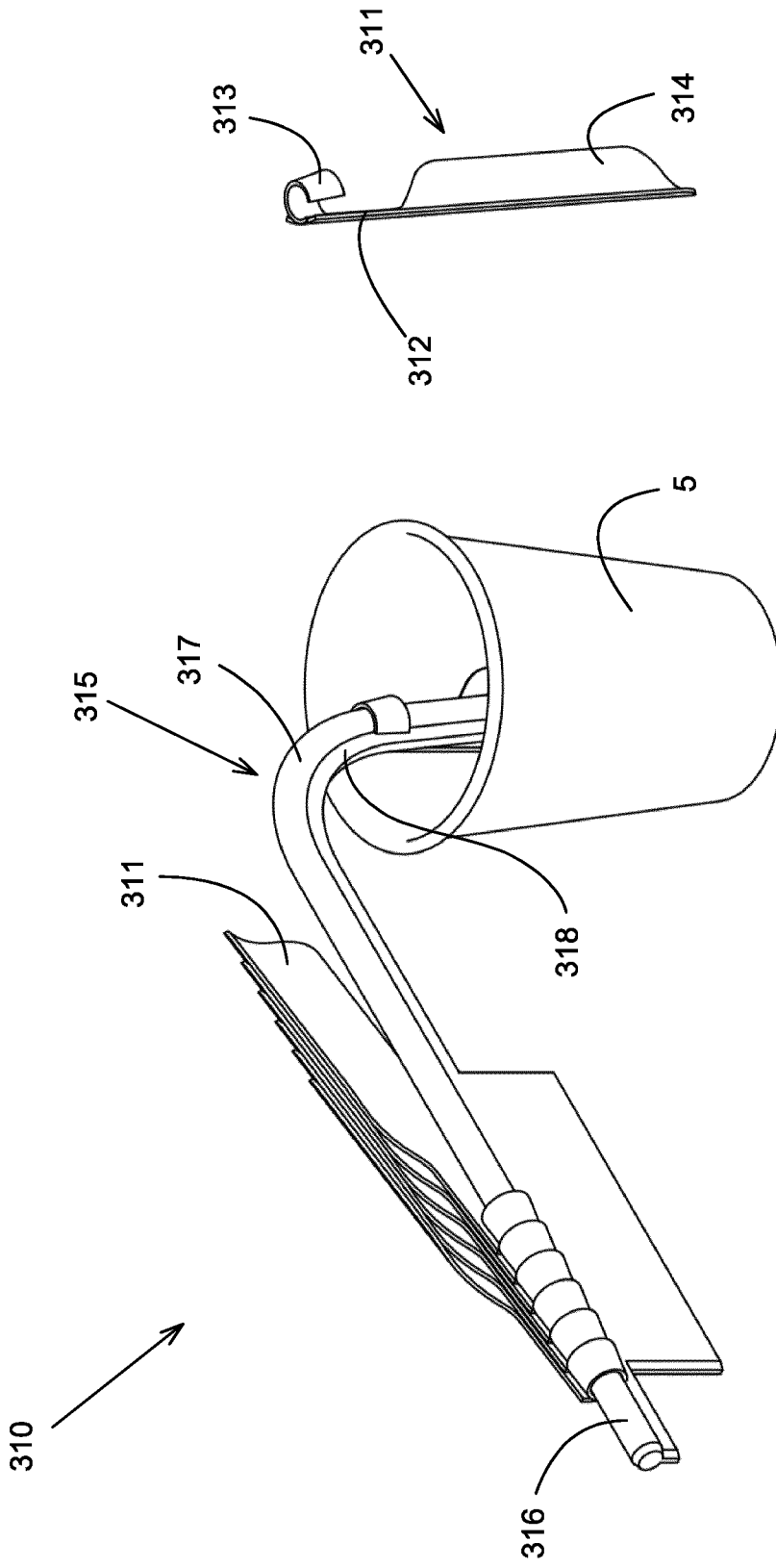

Fig. 12

Fig. 11

INTERNATIONAL SEARCH REPORT

International application No
PCT/EP2019/067731

A. CLASSIFICATION OF SUBJECT MATTER
 INV. H05B6/64 A47J43/07
 ADD.
 According to International Patent Classification (IPC) or to both national classification and IPC

B. FIELDS SEARCHED
 Minimum documentation searched (classification system followed by classification symbols)
 A47J H05B F24C
 Documentation searched other than minimum documentation to the extent that such documents are included in the fields searched

Electronic data base consulted during the international search (name of data base and, where practicable, search terms used)
 EPO-Internal, WPI Data

C. DOCUMENTS CONSIDERED TO BE RELEVANT

Category*	Citation of document, with indication, where appropriate, of the relevant passages	Relevant to claim No.
X A	US 5 021 621 A (DEMMER MARTHA [US] ET AL) 4 June 1991 (1991-06-04) abstract; claim 1; figures 1-3 -----	17,18 1-16
X A	US 5 935 480 A (TAKEOKA NOBUO [JP] ET AL) 10 August 1999 (1999-08-10) abstract; claim 1; figures 1-9 -----	17,18 1-16
X A	US 2006/096979 A1 (KANEKO FUMINORI [JP] ET AL) 11 May 2006 (2006-05-11) abstract; figure 38 -----	17,18 1-16
X A	GB 2 322 271 A (JONES RONALD MARTIN [GB]) 19 August 1998 (1998-08-19) abstract; claim 1; figures 1-3 -----	17,18 1-16

Further documents are listed in the continuation of Box C.

See patent family annex.

* Special categories of cited documents :

<p>"A" document defining the general state of the art which is not considered to be of particular relevance</p> <p>"E" earlier application or patent but published on or after the international filing date</p> <p>"L" document which may throw doubts on priority claim(s) or which is cited to establish the publication date of another citation or other special reason (as specified)</p> <p>"O" document referring to an oral disclosure, use, exhibition or other means</p> <p>"P" document published prior to the international filing date but later than the priority date claimed</p>	<p>"T" later document published after the international filing date or priority date and not in conflict with the application but cited to understand the principle or theory underlying the invention</p> <p>"X" document of particular relevance; the claimed invention cannot be considered novel or cannot be considered to involve an inventive step when the document is taken alone</p> <p>"Y" document of particular relevance; the claimed invention cannot be considered to involve an inventive step when the document is combined with one or more other such documents, such combination being obvious to a person skilled in the art</p> <p>"&" document member of the same patent family</p>
---	---

Date of the actual completion of the international search 13 September 2019	Date of mailing of the international search report 23/09/2019
---	---

Name and mailing address of the ISA/ European Patent Office, P.B. 5818 Patentlaan 2 NL - 2280 HV Rijswijk Tel. (+31-70) 340-2040, Fax: (+31-70) 340-3016	Authorized officer Garcia, Jesus
--	--

INTERNATIONAL SEARCH REPORT

Information on patent family members

International application No PCT/EP2019/067731

Patent document cited in search report	Publication date	Patent family member(s)	Publication date
US 5021621	A	04-06-1991	NONE
US 5935480	A	10-08-1999	CN 1189596 A 05-08-1998
			JP 3234911 B2 04-12-2001
			JP H10211098 A 11-08-1998
			KR 19980070701 A 26-10-1998
			US 5935480 A 10-08-1999
US 2006096979	A1	11-05-2006	AU 2003255163 A1 23-02-2004
			CN 1672467 A 21-09-2005
			US 2006096979 A1 11-05-2006
			WO 2004014107 A1 12-02-2004
GB 2322271	A	19-08-1998	NONE