

Oct. 5, 1965

K. DEBUS

3,209,902

SLUG TRIMMING ARRANGEMENT FOR LINE CASTING MACHINE

Filed May 1, 1963

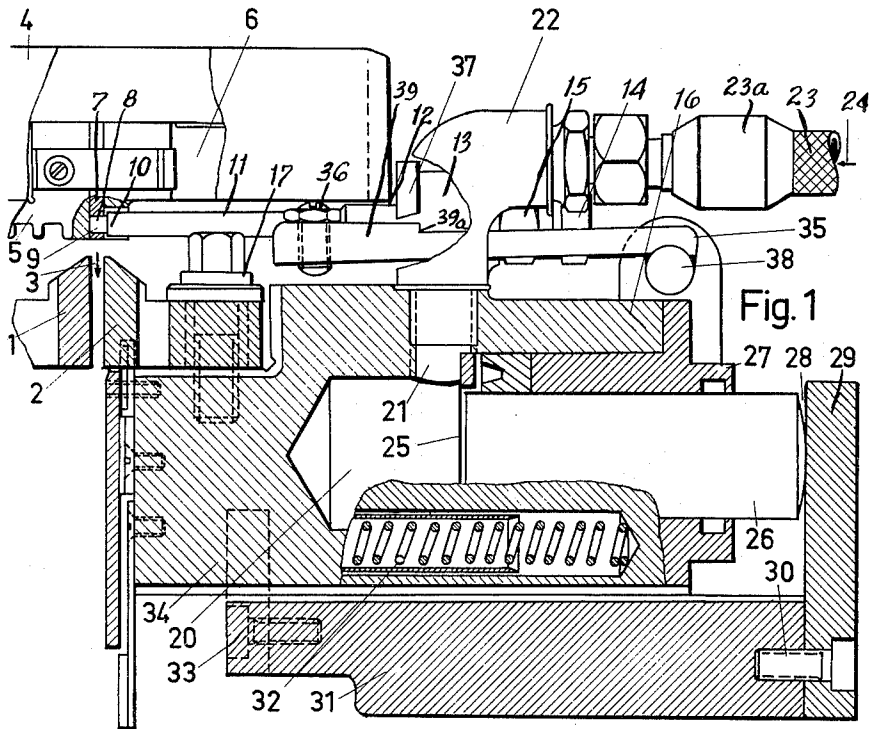

Fig. 1

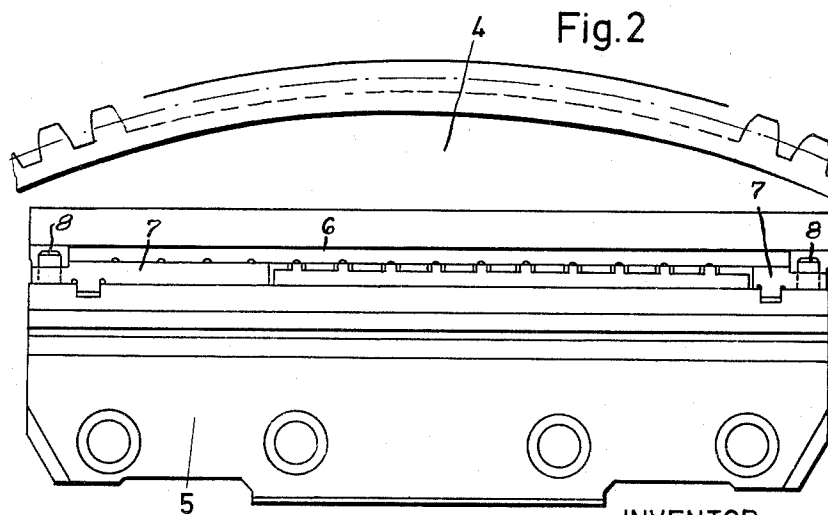

Fig. 2

INVENTOR
Karl Debus
BY
Michael S. Striker
ATTORNEY

1

3,209,902

SLUG TRIMMING ARRANGEMENT FOR LINE CASTING MACHINE

Karl Debus, Bad Homburg von der Hohe, Germany, assignor to Linotype G.m.b.H., Frankfurt am Main, Germany

Filed May 1, 1963, Ser. No. 277,228

Claims priority, application Germany, May 5, 1962, L 41,926

19 Claims. (Cl. 199—54)

The present invention relates to a slug trimming arrangement for line casting machines, and more particularly to an arrangement for automatically placing the trimming and shaving knives in a position spaced according to the thickness of the slug to be trimmed.

In line casting machines, such as Linotype machines, a slug is cast in a mold and then ejected by ejector blades from the mold to pass between a pair of trimming or shaving knives which trim it true on the sides so that the same are smooth and parallel.

Since the cast slugs vary between 5 and 45 points in thickness, the distance between the trimming knives must be adjusted in accordance with the thickness of the slugs.

In known line casting machines, a series of setting screws are arranged in a circle, and can be successively placed in a position cooperating with a stop on a knife block which carries the movable knife. The setting screws have lengths corresponding to different point sizes whereby the spacing between the trimming knives in the cutting position is determined. The point size of the operative set screw is read by the operator on an indicator. The set spacing between the trimming knives is selected to correspond to the point size of the slug.

In another known arrangement, the knives are resiliently urged apart by guides on the mold to assume the spacing necessary for the trimming operation. This arrangement has the disadvantage that the knives are not positively held properly spaced in the cutting position, and that the adjustment depends on the resilient force of the spring means which is different for slugs of different point size. Furthermore, a fine and accurate adjustment of the knife is not possible. The range of adjustment is limited, since the adjustment depends on the axial movement of the mold disc, which is generally only a few millimeters.

It is one object of the present invention to overcome the disadvantages of the known devices for setting the trimming knives of a line casting machine, and to provide a slug trimming arrangement which reliably and accurately operates.

Another object of the present invention is to provide a slug trimming arrangement in which the trimming knives are positively blocked in the cutting position.

Another object of the present invention is to provide a slug trimming arrangement which is automatically operated under the control of the moving mold disc, but derives the forces for moving the knife block from another source.

With these objects in view, the present invention relates to a slug trimming arrangement for moving the cutting means by which a slug ejected from a mold is trimmed to a predetermined size. One embodiment of the invention comprises a pair of cutting means, of which one is fixed knife, and the other is a knife mounted on a knife block for movement between an inoperative position and a cutting position closely spaced from the fixed knife. Actuating means, preferably in the form of a hydraulic motor with a return spring, are provided for urging the knife block with the movable knife toward the fixed knife. Abutment means including an abutment on the mold and an adjustable abutment on the knife block, positively block

2

movement of the knife block when the two knives are in the desired cutting position in which the knives are spaced from each other a distance exactly corresponding to the predetermined size of the slug.

In the preferred embodiment of the invention, a pair of posts, corresponding in point size to the point size of the slug, are provided on the liners of the mold, and cooperate with a pair of adjustable abutment screws on the knife block to stop the knife block in the desired cutting position. The adjustable screw permits an accurate adjustment of the knife block to a position in which the knives are exactly parallel. Such an adjustment is necessitated even if very close tolerances are observed in the manufacture of the movable parts of the knife block.

One embodiment of the invention employs a hydraulic motor for moving the knife block toward the fixed knife, and spring means for returning the knife block to its inoperative position. This arrangement is particularly advantageous, since hydraulic pressure fluid is available at the line casting machine, and the force of the hydraulic motor is sufficient to lock the knife block when the same abuts the abutment means on the mold and is thus positively blocked.

The knife block is preferably locked by stop means in an inoperative position in which the knives are spaced a maximum distance, and the mold releases the stop means when moving for the ejection of a slug from the mold. When the knife block is thus released, the hydraulic motor moves it toward the fixed knife until the knife block is again stopped by the positive engagement between the abutment means on the mold and the adjustable abutment means on the knife block.

The novel features which are considered as characteristic for the invention are set forth in particular in the appended claims. The invention itself, however, both as to its construction and its method of operation together with additional objects and advantages thereof, will be best understood from the following description of specific embodiments when read in connection with the accompanying drawing, in which:

FIG. 1 is a plan view, partly in horizontal section; and

FIG. 2 is a fragmentary front view illustrating the mold means on the mold disc.

Referring now to the drawings, and more particularly to FIG. 1, a fixed cutting means or knife 1 is mounted on the machine by means which are conventional, and not shown. A second knife 2 is mounted on a knife block slide 16 by a pair of screws 17. In the cutting position illustrated in FIG. 1, knives 1 and 2 are spaced a distance corresponding to the thickness of slug which is ejected in the direction of the arrow 3 from the mold means which are mounted on the mold disc 4. The mold means includes a lower part 5, an upper part 6, and two liners 7, as best seen in FIG. 2. Liners 7 determine the length and width of the mold slot corresponding to the desired point sizes of the cast slug. An abutment post 8 is secured to each liner 7 and forms an abutment on the mold means by which the cutting position of the movable knife 2 is determined, as will be explained hereinafter.

Slide 16 is formed with an inner pressure chamber 20 which communicates with a threaded bore 21 into which a pipe means 22 is threaded. A hose 23 is coupled to pipe knee 22 for supplying pressure oil in the direction of the arrow 24 to the pressure chamber 20. A suitable valve 23a is provided for controlling the flow of pressure oil through the pipes 22 and 23. The pressure chamber 20 is closed by a bushing 27 in which a piston member 26 is located. Piston member 26 abuts at the outer end thereof on a wall 29 secured by screws 30 to a fixed casing 31 on which a stop plate 34 is mounted by means of

screws 33. A spring 32 is mounted in a cavity of slide 16 and abuts the same and also stop plate 34 of the fixed support or casing 31 so that spring 32 urges slide 16 to move to the right as viewed in FIG. 1 to an inoperative position in which the knives 1 and 2 are spaced a greater distance. However, the oil pressure in chamber 20 acting on the front face 25 of piston member 26 is greater than the force of spring 32, so that slide 16 with knife 2 is urged to move to left as viewed in FIG. 1. A supporting block 13 is secured to or integral with knife block slide 16 and is formed with a pair of threaded bores into which a pair of adjustable abutment screws 12 are threaded. Screws 12 have adjustable heads 14 and locking nuts 15. Each adjusting screw has a stem portion 11 cooperating with one of the abutment posts 8 of the mold means. In the position of FIG. 1, the fluid pressure in chamber 20 has moved slide 16 so far to the left that the adjustable abutment screws 11 abut the posts 8, and consequently stop the knife block slide 16 in a position in which the knives 1 and 2 are spaced in accordance with the length of the posts 8. This length is selected to correspond to the point size of the slug cast in the respective mold having liners 7 and posts 8.

When the pressure is relieved in chamber 20, spring 32 moves the knife block slide 16 to the right as viewed in FIG. 1. A stop lever 39 is mounted by its end portion 35 on a pivot means 38 which is turnable in a stationary bracket. The free end of stop lever 39 carries an adjustable stop screw 36 which is urged into engagement with mold disc 4 by a spring, not shown, acting on stop lever 39 to turn the same in clockwise direction. Stop lever 39 has a locking shoulder 39a cooperating with a fixed stop 37 on support block 13 of knife block slide 16. When knife block slide 16 with support block 13 and stop 37 has moved to the right as viewed in FIG. 1 to a position in which stop 37 and shoulder 39a register, stop lever 39 will snap to a position in which shoulder 39a faces a corresponding opposite face on stop 37, which is possible since the mold disc was previously retracted from the illustrated position.

During such movement, the knives have moved apart, and when it is again desired to move the knives to the cutting position, the valve 23a is operated and pressure oil is supplied to chamber 20 so that the same urges knife block slide 16 to move to left as viewed in FIG. 1. However, such movement of the knife block slide 16 is blocked due to the engagement between shoulder 39a and stop 37.

During the ejecting operation, mold disc 4 is moved in the direction of the arrow 3 so that mold disc 4 engages adjusting screw 36 and turns lever 39 in counter-clockwise direction to a position releasing stop 37. The hydraulic pressure in chamber 20 will immediately cause movement of the knife block slide 16 to the left until the end faces 9 of the two adjustable abutment screw means 11, 12, 14 engage the end faces of the abutment posts 8. The knife block 16, and knife 2 are positively blocked in this position due to the abutment between the abutment means 8 and 11 which engage each other under the great pressure of hydraulic fluid in pressure chamber 20.

The gap between the knives 1 and 2 is thus accurately determined in accordance with the length of the posts 8 which corresponds to the point size of the cast slug.

The moment in which the knife block is released for movement to the left can be accurately adjusted relative to the molding and ejecting operation by adjustment of stop screw 36.

The arrangement of the present invention has the advantage that the desired distance between the two cutting means is automatically adjusted in accordance with the thickness of the cast slug, without any setting operation by the operator. On the other hand, the cutting means are positively held at the desired distance by rigid abut-

ment means which are subjected to the great force of the hydraulic pressure fluid.

It will be understood that each of the elements described above or two or more together, may also find a useful application in other types of slug trimming arrangements for line casting machines differing from the types described above.

While the invention has been illustrated and described as embodied in an automatic slug trimming arrangement in which a hydraulically operated knife block is positively blocked by abutment means on the mold and on the knife block, it is not intended to be limited to the details shown, since various modifications and structural changes may be made without departing in any way from the spirit of the present invention.

Without further analysis the foregoing will so fully reveal the gist of the present invention that others can by applying current knowledge readily adapt it for various applications without omitting features that, from the standpoint of prior art, fairly constitute essential characteristics of the generic or specific aspects of this invention and, therefore, such adaptations should and are intended to be comprehended within the meaning and range of equivalence of the following claims.

What is claimed and desired to be secured by Letters Patent is:

1. A slug trimming arrangement for line casting machines, comprising, in combination, mold means for forming a slug; a pair of cutting means for trimming a slug ejected from said mold means to a predetermined size; actuating means for urging one of said cutting means toward the other cutting means; and abutment means on said mold means for positively blocking movement of said one cutting means toward the other cutting means in a cutting position in which said cutting means are spaced from each other a distance corresponding to said predetermined size of the slug.

2. A slug trimming arrangement for line casting machines, comprising, in combination, mold means for forming a slug; a pair of cutting means for trimming a slug ejected from said mold means to a predetermined size; actuating means for urging one of said cutting means toward the other cutting means; and abutment means on said mold means and on said one cutting means for positively blocking movement of said one cutting means toward the other cutting means in a cutting position in which said cutting means are held by said actuating means spaced from each other a distance corresponding to said predetermined size of the slug.

3. A slug trimming arrangement for line casting machines, comprising, in combination, mold means for forming a slug and including liner means having an abutment; a pair of cutting means for trimming a slug ejected from said mold means to a predetermined size; actuating means for urging one of said cutting means toward the other cutting means; and abutment means on said one cutting means engageable with said abutment of said liner means for positively blocking movement of said one cutting means toward the other cutting means in a cutting position in which said cutting means are held by said actuating means spaced from each other a distance corresponding to said predetermined size of the slug.

4. A slug trimming arrangement for line casting machines, comprising, in combination, mold means for forming a slug and including liner means having spacing post means; a pair of cutting means for trimming a slug ejected from said mold means to a predetermined size; actuating means for urging one of said cutting means toward the other cutting means; and abutment means on said one cutting means engageable with said spacing post means of said liner means for positively blocking movement of said one cutting means toward the other cutting means in a cutting position in which said cutting means are held by said actuating means spaced from each other a distance corresponding to said predetermined size of the slug.

5. A slug trimming arrangement for line casting machines, comprising in combination, mold means for forming a slug, a pair of cutting means for trimming a slug to a predetermined size; hydraulic actuating means for urging one of said cutting means toward the other cutting means; and abutment means on said mold means for positively blocking movement of said one cutting means toward the other cutting means in a cutting position in which said cutting means are spaced from each other held by said actuating means corresponding to said predetermined size of the slug.

6. A slug trimming arrangement for line casting machines, comprising, in combination, mold means for forming a slug; a pair of cutting means for trimming a slug ejected from said mold means to a predetermined size; hydraulic actuating means for urging one of said cutting means toward the other cutting means; biasing means for urging said one cutting means away from said other cutting means with a force smaller than the force of said hydraulic actuating means; and abutment means on said mold means and said one cutting means for positively blocking movement of said one cutting means toward the other cutting means in a cutting position in which said cutting means are spaced from each other a distance corresponding to said predetermined size of the slug, the pressure of said hydraulic actuating means increasing when said one cutting means is blocked whereby the same is firmly held in said cutting position.

7. A slug trimming arrangement for line casting machines, comprising, in combination, mold means for forming a slug and including liner means having an abutment; a pair of cutting means for trimming a slug ejected from said mold means to a predetermined size; hydraulic actuating means for urging one of said cutting means toward the other cutting means; spring means for urging said one cutting means away from said other cutting means with a force smaller than the force of said hydraulic actuating means; and abutment means on said one cutting means engagable with said abutment on said liner means of said mold means for positively blocking movement of said one cutting means toward the other cutting means in a cutting position in which said cutting means are spaced from each other a distance corresponding to said predetermined size of the slug, the pressure of said hydraulic actuating means increasing when said one cutting means is blocked whereby the same is firmly held in said cutting position.

8. A slug trimming arrangement for line casting machines, comprising, in combination, a mold means for forming a slug and having a rigid fixed abutment; a pair of cutting means for trimming a slug ejected from said mold means to a predetermined size; actuating means for urging one of said cutting means toward the other cutting means; and adjustable abutment means mounted on said one cutting means engagable with said fixed abutment of said liner means for positively blocking movement of said one cutting means toward the other cutting means in a cutting position in which said cutting means are held by said actuating means are spaced from each other a distance corresponding to said predetermined size of the slug.

9. A slug trimming arrangement for line casting machines, comprising, in combination, a mold means for forming a slug and being movable for the ejection of a slug; a pair of cutting means for trimming a slug ejected from said mold means to a predetermined size and having a farther spaced inoperative position and a closely spaced cutting position; actuating means for urging one of said cutting means toward the other cutting means; stop means for blocking movement of said one cutting means in said inoperative position and being engaged and released by said mold means moving for the ejection of a slug so that said one cutting means starts its movement toward said cutting position; and abutment means for positively blocking movement of said one cutting means toward the

other cutting means in said cutting position in which said cutting means are held by said actuating means spaced from each other a distance corresponding to said predetermined size of the slug.

10. A slug trimming arrangement for line casting machines, comprising, in combination, mold means for forming a slug and being movable for the ejection of a slug; a pair of cutting means for trimming a slug ejected from said mold means to a predetermined size and having a farther spaced inoperative position and a closely spaced cutting position; hydraulic actuating means for urging one of said cutting means toward the other cutting means; stop means for blocking movement of said one cutting means in said inoperative position and being engaged and released by said mold means moving for the ejection of a slug so that said one cutting means starts its movement toward said cutting position; and abutment means on said mold means and on said one cutting means for positively blocking movement of said one cutting means toward the other cutting means in said cutting position in which said cutting means are spaced from each other a distance corresponding to said predetermined size of the slug, the pressure of said hydraulic actuating means increasing when said one cutting means is blocked whereby the same is firmly held in said cutting position.

11. A slug trimming arrangement for a line casting machine, comprising, in combination, a supporting means mold means mounted on said supporting means for forming an ejectable slug; a fixed cutting means mounted on said supporting means in the proximity of said mold means; a knife block carrying a knife and being movably mounted on said supporting means for moving said knife between an inoperative position farther spaced from said cutting means and a cutting position spaced from said cutting means a distance corresponding to the thickness of the slug; actuating means for urging said knife block and said knife from said inoperative position to said cutting position; and abutment means on said knife block for engaging said mold means in said cutting position of said knife to positively block movement of said knife block and of said knife so that said knife block and said knife are held by said actuating means in said cutting position.

12. A slug trimming arrangement for a line casting machine, comprising, in combination, a supporting means; mold means mounted on said supporting means for forming an ejectable slug and including liner means having a post corresponding in point size to the point size of the slug; a fixed cutting means mounted on said supporting means in the proximity of said mold means; a knife block carrying a knife and being movably mounted on said supporting means for moving said knife between an inoperative position farther spaced from said cutting means and a cutting position spaced from said cutting means a distance corresponding to the thickness of the slug; actuating means for urging said knife block and said knife from said inoperative position to said cutting position; and abutment means on said knife block for engaging said post of said liner of said mold means in said cutting position of said knife to positively block movement of said knife block and of said knife so that said knife block and said knife are held by said actuating means in said cutting position.

13. A slug trimming arrangement for a line casting machine, comprising, in combination, a supporting means; mold means mounted on said supporting means for forming an ejectable slug and including liner means having a post corresponding in point size to the point size of the slug; a fixed cutting means mounted on said supporting means in the proximity of said mold means; a knife block carrying a knife and being movably mounted on said supporting means for moving said knife between an inoperative position farther spaced from said cutting means and a cutting position spaced from said cutting means a distance corresponding to the thickness of the slug; actuating

means for urging said knife block and said knife from said inoperative position to said cutting position; and abutment means including adjustable threaded means mounted on said knife block for engaging said post of said liner of said mold means in said cutting position of said knife to positively block movement of said knife block and of said knife so that said knife block and said knife are held by said actuating means in said cutting position.

14. A slug trimming arrangement for a line casting machine, comprising, in combination, a supporting means, mold means mounted on said supporting means for forming an ejectable slug and including liner means having a post corresponding in point size to the point size of the slug; a fixed cutting means mounted on said supporting means in the proximity of said mold means; a knife block carrying a knife and being movably mounted on said supporting means for moving said knife between an inoperative position farther spaced from said cutting means and a cutting position spaced from said cutting means a distance corresponding to the thickness of the slug; hydraulic actuating means for urging said knife block and said knife from said inoperative position to said cutting position; means controlling said actuating means to start movement of said knife block from said inoperative position to said cutting position; and abutment means including adjustable means mounted on said knife block for engaging said post of said liner of said mold means in said cutting position of said knife to positively block movement of said knife block and of said knife so that said knife block and said knife are held by said actuating means in said cutting position.

15. A slug trimming arrangement for a line casting machine, comprising, in combination, a supporting means; mold means for forming an ejectable slug and including liner means having a post corresponding in point size to the point size of the slug, said mold means being, movably mounted on said supporting means for the ejection of a slug; a fixed cutting means mounted on said supporting means in the proximity of said mold means; a knife block carrying a knife and being movably mounted on said supporting means for moving said knife between an inoperative position farther spaced from said cutting means and a cutting position spaced from said cutting means a distance corresponding to the thickness of the slug; hydraulic actuating means for urging said knife block and said knife from said inoperative position to said cutting position; spring means urging said knife block with said knife from said cutting position to said inoperative position and having a lesser force than said hydraulic actuating means; means controlling said actuating means to start movement of said knife block from said inoperative position to said cutting position and being actuated by said mold means moving for the ejection of a slug; and abutment means mounted on said knife block for engaging post of said liner of said mold means in said cutting position of said knife to positively block movement of said knife block and of said knife so that said knife block and said knife are held by said hydraulic actuating means in said cutting position.

16. A slug trimming arrangement for a line casting machine, comprising, in combination, a supporting means; mold means for forming an ejectable slug, said mold means being movably mounted on said supporting means for the ejection of a slug; a fixed cutting means mounted on said supporting means in the proximity of said mold means; a knife block carrying a knife and being movably mounted on said supporting means for moving said knife between an inoperative position farther spaced from said cutting means and a cutting position spaced from said cutting means a distance corresponding to the thickness of the slug, said knife block having a stop means; hydraulic actuating means for urging said knife block and said knife from said inoperative position to

said cutting position; a shiftable stop lever mounted on said supporting means for movement between a releasing position, and a stop position for engaging said stop means for blocking movement of said knife block in said inoperative position, said stop lever being biased toward said stop position and disposed to be engaged and shifted to said releasing position by said mold means upon movement of the same to release said stop means so that said knife block is moved by said hydraulic actuating means toward said cutting means; and abutment means on said knife block for engaging said mold means in said cutting position of said knife to positively block movement of said knife block and of said knife so that said knife block and said knife are held by said hydraulic actuating means in said cutting position.

17. A slug trimming arrangement for a line casting machine, comprising, in combination, a supporting means; mold means mounted on said supporting means for forming an ejectable slug and having an abutment; a fixed cutting means mounted on said supporting means in the proximity of said mold means; a knife block carrying a knife and being movably mounted on said supporting means for moving said knife between an inoperative position farther spaced from said cutting means and a cutting position spaced from said cutting means a distance corresponding to the thickness of the slug; actuating means for urging said knife block and said knife from said inoperative position to said cutting position; and adjustable abutment means on said knife block for engaging said abutment of said mold means in said cutting position of said knife to positively block movement of said knife block and of said knife so that said knife block and said knife are held by said actuating means in said cutting position.

18. A slug trimming arrangement for a line casting machine, comprising, in combination, a supporting means; mold means mounted on said supporting means for forming an ejectable slug and having an abutment; a fixed cutting means mounted on said supporting means in the proximity of said mold means; a knife block carrying a knife and being movably mounted on said supporting means for moving said knife between an inoperative position farther spaced from said cutting means and a cutting position spaced from said cutting means a distance corresponding to the thickness of the slug; hydraulic actuating means for urging said knife block and said knife from said inoperative position to said cutting position; spring means mounted on said supporting means for urging said knife block with said knife from said cutting position to said inoperative position and having a lesser force than said hydraulic actuating means; adjustable abutment means on said knife block for engaging said abutment of said mold means in said cutting position of said knife to positively block movement of said knife block and of said knife so that said knife block and said knife are held by said hydraulic actuating means in said cutting position.

19. A slug trimming arrangement as set forth in claim 18 wherein said mold means include a liner having a pair of posts corresponding in point size to the slug and constituting said abutment of said mold means; and wherein said adjustable abutment means includes a pair of adjustable screws mounted on said knife and respectively cooperating with said posts to stop said knife block in said cutting position of said knife.

References Cited by the Examiner

UNITED STATES PATENTS

2,123,557 7/38 Albrecht 199—59

EUGENE R. CAPOZIO, *Primary Examiner*.

WILLIAM B. PENN, *Examiner*.